

# MOB. Horizontal toggle clamps

with straight base, steel



- 1
- 2
- 3
- 4
- 5
- 6
- 7
- 8
- 9
- 10
- 11
- 12
- 13
- 14
- 15
- 16
- 17
- 18

## MATERIAL

C10 zinc-plated steel.

## RIVETS

Zinc-plated steel.

## SUPPORT BUSHINGS

Hardened and ground steel (for sizes  $\geq 355$ ).

## HANDLE

Polyurethane, red colour.

## STANDARD EXECUTIONS

- **MOB-N**: with open clamping lever and two folded washers.
- **MOB-P**: with solid clamping lever and bolt retainer.

## CLAMPING BOLT

To be ordered separately.

## FEATURES AND APPLICATIONS

All articulated joints are lubricated with special grease.

Main feature of MOB. toggle clamps is the low closing profile. These tools are designed to avoid that the operator's fingers may be hit by the lever while opening.

During clamping, the lever is controlled to prevent impact on functioning due to side thrust.

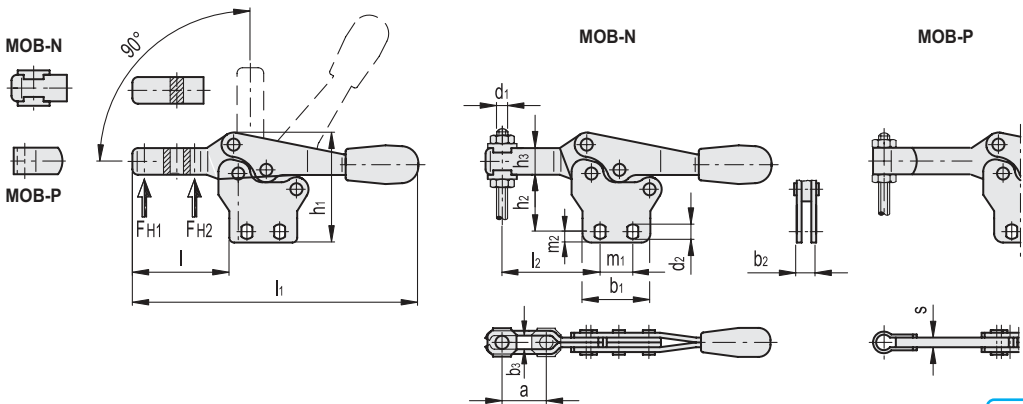
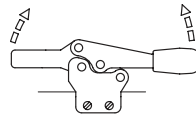

## MOB-N

		METRIC																
Code	Description	a	b <sub>1</sub>	b <sub>2</sub>	b <sub>3</sub>	d <sub>1</sub>	d <sub>2</sub>	h <sub>1</sub>	h <sub>2</sub>	h <sub>3</sub>	l	l <sub>1</sub>	l <sub>2</sub>	m <sub>1</sub>	m <sub>2</sub>	FH1* [N]	FH2* [N]	$\Delta$
GG.AD080	MOB.75-N	20	28	8	5.5	M5	4.5	44.5	24+25.5	11	40	118	40	13.5	4.5	900	1350	88
GG.AD140	MOB.130-N	32	36	10	6.5	M6	5.5	64	35+38	16	56	170	53	26	7	1000	2000	200
GG.AD275	MOB.230-N	37	44	12	8.5	M8	6.5	74.5	42+44.5	18	65	195	63.5	26	6.8	1700	3300	330
GG.AD375	MOB.355-N	58	60	14	10	M10	8.5	102	60+62	22	100	269	96	41	7.5	1800	4000	700
GG.AD475	MOB.455-N	65	70	18	12.4	M12	8.5	119	68+69.5	26	115	308	116	41.5	11.8	3200	6200	1200

## MOB-P

		METRIC														
Code	Description	b <sub>1</sub>	b <sub>2</sub>	d <sub>1</sub>	d <sub>2</sub>	h <sub>1</sub>	h <sub>2</sub>	h <sub>3</sub>	l	l <sub>1</sub>	m <sub>1</sub>	m <sub>2</sub>	s	FH1* [N]	FH2* [N]	$\Delta$
GG.AD090	MOB.75-P	28	8	M5	4.5	44.5	24+25.5	11	40.5	118.5	13.5	4.5	4	900	1350	88
GG.AD150	MOB.130-P	36	10	M6	5.5	64	35+38	16	57	171	26	7	5	1000	2000	200
GG.AD285	MOB.230-P	44	12	M8	6.5	74.5	42+44.5	18	67	197	26	6.8	6	1700	3300	340
GG.AD385	MOB.355-P	60	14	M10	8.5	102	60+62	22	102	271	41	7.5	7	1800	4000	720
GG.AD485	MOB.455-P	70	18	M12	8.5	119	68+69.5	26	117	310	41.5	11.8	10	3200	6200	1230

Toggle clamps

\* Holding force.