



**MICROCHIP**

---

# **Resistive Temperature Detector (RTD) Reference Design**

---

**Note the following details of the code protection feature on Microchip devices:**

- Microchip products meet the specification contained in their particular Microchip Data Sheet.
- Microchip believes that its family of products is one of the most secure families of its kind on the market today, when used in the intended manner and under normal conditions.
- There are dishonest and possibly illegal methods used to breach the code protection feature. All of these methods, to our knowledge, require using the Microchip products in a manner outside the operating specifications contained in Microchip's Data Sheets. Most likely, the person doing so is engaged in theft of intellectual property.
- Microchip is willing to work with the customer who is concerned about the integrity of their code.
- Neither Microchip nor any other semiconductor manufacturer can guarantee the security of their code. Code protection does not mean that we are guaranteeing the product as "unbreakable."

Code protection is constantly evolving. We at Microchip are committed to continuously improving the code protection features of our products. Attempts to break Microchip's code protection feature may be a violation of the Digital Millennium Copyright Act. If such acts allow unauthorized access to your software or other copyrighted work, you may have a right to sue for relief under that Act.

---

Information contained in this publication regarding device applications and the like is provided only for your convenience and may be superseded by updates. It is your responsibility to ensure that your application meets with your specifications. MICROCHIP MAKES NO REPRESENTATIONS OR WARRANTIES OF ANY KIND WHETHER EXPRESS OR IMPLIED, WRITTEN OR ORAL, STATUTORY OR OTHERWISE, RELATED TO THE INFORMATION, INCLUDING BUT NOT LIMITED TO ITS CONDITION, QUALITY, PERFORMANCE, MERCHANTABILITY OR FITNESS FOR PURPOSE. Microchip disclaims all liability arising from this information and its use. Use of Microchip devices in life support and/or safety applications is entirely at the buyer's risk, and the buyer agrees to defend, indemnify and hold harmless Microchip from any and all damages, claims, suits, or expenses resulting from such use. No licenses are conveyed, implicitly or otherwise, under any Microchip intellectual property rights.

**Trademarks**

The Microchip name and logo, the Microchip logo, dsPIC, KEELOQ, KEELOQ logo, MPLAB, PIC, PICmicro, PICSTART, PIC<sup>32</sup> logo, rPIC and UNI/O are registered trademarks of Microchip Technology Incorporated in the U.S.A. and other countries.

FilterLab, Hampshire, HI-TECH C, Linear Active Thermistor, MXDEV, MXLAB, SEEVAL and The Embedded Control Solutions Company are registered trademarks of Microchip Technology Incorporated in the U.S.A.

Analog-for-the-Digital Age, Application Maestro, CodeGuard, dsPICDEM, dsPICDEM.net, dsPICworks, dsSPEAK, ECAN, ECONOMONITOR, FanSense, HI-TIDE, In-Circuit Serial Programming, ICSP, Mindi, MiWi, MPASM, MPLAB Certified logo, MPLIB, MPLINK, mTouch, Omniscient Code Generation, PICC, PICC-18, PICDEM, PICDEM.net, PICKit, PICtail, REAL ICE, rLAB, Select Mode, Total Endurance, TSHARC, UniWinDriver, WiperLock and ZENA are trademarks of Microchip Technology Incorporated in the U.S.A. and other countries.

SQTP is a service mark of Microchip Technology Incorporated in the U.S.A.

All other trademarks mentioned herein are property of their respective companies.

© 2010, Microchip Technology Incorporated, Printed in the U.S.A., All Rights Reserved.

 Printed on recycled paper.

ISBN: 978-1-63276-347-1

*Microchip received ISO/TS-16949:2002 certification for its worldwide headquarters, design and wafer fabrication facilities in Chandler and Tempe, Arizona; Gresham, Oregon and design centers in California and India. The Company's quality system processes and procedures are for its PIC<sup>®</sup> MCUs and dsPIC<sup>®</sup> DSCs, KEELOQ<sup>®</sup> code hopping devices, Serial EEPROMs, microperipherals, nonvolatile memory and analog products. In addition, Microchip's quality system for the design and manufacture of development systems is ISO 9001:2000 certified.*

**QUALITY MANAGEMENT SYSTEM  
CERTIFIED BY DNV  
== ISO/TS 16949:2002 ==**

**Table of Contents**

<b>Preface .....</b>	<b>5</b>
Introduction.....	5
Document Layout .....	5
Conventions Used in this Guide .....	6
Recommended Reading.....	7
The Microchip Web Site .....	7
Customer Support .....	7
Document Revision History .....	7
 <b>Chapter 1. Product Overview</b>	
1.1 Introduction .....	9
1.2 What is the RTD Reference Design? .....	9
1.3 What the RTD Reference Design kit includes .....	9
 <b>Chapter 2. Installation and Operation</b>	
2.1 Introduction .....	11
2.2 Features .....	11
2.3 Getting Started .....	12
 <b>Appendix A. Schematic and Layouts</b>	
A.1 Introduction .....	17
A.2 Board - Schematic .....	18
A.3 Board - Top Silk and Pads .....	19
A.4 Board - Top Layer .....	19
A.5 Board - Bottom Silk and Pads .....	20
A.6 Board - Bottom Layer .....	20
 <b>Appendix B. Bill of Materials</b>	
<b>Worldwide Sales and Service .....</b>	<b>22</b>

# RTD Reference Design

---

NOTES:

---

---

## Preface

---

---

### NOTICE TO CUSTOMERS

All documentation becomes dated, and this manual is no exception. Microchip tools and documentation are constantly evolving to meet customer needs, so some actual dialogs and/or tool descriptions may differ from those in this document. Please refer to our web site ([www.microchip.com](http://www.microchip.com)) to obtain the latest documentation available.

Documents are identified with a “DS” number. This number is located on the bottom of each page, in front of the page number. The numbering convention for the DS number is “DSXXXXA”, where “XXXX” is the document number and “A” is the revision level of the document.

For the most up-to-date information on development tools, see the MPLAB® IDE on-line help. Select the Help menu, and then Topics to open a list of available online help files.

## INTRODUCTION

This chapter contains general information that will be useful to know before using the RTD Reference Design. Items discussed in this chapter include:

- Document Layout
- Conventions Used in this Guide
- Recommended Reading
- The Microchip Web Site
- Customer Support
- Document Revision History

## DOCUMENT LAYOUT

This document describes how to use the RTD Reference Design as a development tool to emulate and debug firmware on a target board. The manual layout is as follows:

- **Chapter 1. “Product Overview”** – Important information about the RTD Reference Design.
- **Chapter 2. “Installation and Operation”** – This chapter includes a detailed description of each function of the demo board and instructions for how to begin using the board.
- **Appendix A. “Schematic and Layouts”** – Shows the schematic and layout diagrams for the RTD Reference Design.
- **Appendix B. “Bill of Materials”** – Lists the parts used to build the RTD Reference Design.

# RTD Reference Design

---

## CONVENTIONS USED IN THIS GUIDE

This manual uses the following documentation conventions:

### DOCUMENTATION CONVENTIONS

Description	Represents	Examples
<b>Arial font:</b>		
Italic characters	Referenced books	<i>MPLAB<sup>®</sup> IDE User's Guide</i>
	Emphasized text	...is the <i>only</i> compiler...
Initial caps	A window	the Output window
	A dialog	the Settings dialog
	A menu selection	select Enable Programmer
Quotes	A field name in a window or dialog	"Save project before build"
Underlined, italic text with right angle bracket	A menu path	<u><i>File&gt;Save</i></u>
Bold characters	A dialog button	Click <b>OK</b>
	A tab	Click the <b>Power</b> tab
N'Rnnnn	A number in verilog format, where N is the total number of digits, R is the radix and n is a digit.	4'b0010, 2'hF1
Text in angle brackets < >	A key on the keyboard	Press <Enter>, <F1>
<b>Courier New font:</b>		
Plain Courier New	Sample source code	#define START
	Filenames	autoexec.bat
	File paths	c:\mcc18\h
	Keywords	_asm, _endasm, static
	Command-line options	-Opa+, -Opa-
	Bit values	0, 1
	Constants	0xFF, 'A'
Italic Courier New	A variable argument	<i>file.o</i> , where <i>file</i> can be any valid filename
Square brackets [ ]	Optional arguments	mcc18 [options] <i>file</i> [options]
Curly brackets and pipe character: {   }	Choice of mutually exclusive arguments; an OR selection	errorlevel {0 1}
Ellipses...	Replaces repeated text	var_name [, var_name...]
	Represents code supplied by user	void main (void) { ... }

## RECOMMENDED READING

This user's guide describes how to use the RTD Reference Design. Other useful documents are listed below. The following Microchip documents are available and recommended as supplemental reference resources.

**MCP3551 Data Sheet, “Low-Power, Single-Channel 22-Bit Delta-Sigma ADCs” (DS21950)**

This data sheet provides detailed information regarding the MCP3551 device.

**AN1154 - “Precision RTD Instrumentation for Temperature Sensing” (DS01154)**

This application note provides information on the RTD Instrumentation technique for high performance thermal management applications.

## THE MICROCHIP WEB SITE

Microchip provides online support via our web site at [www.microchip.com](http://www.microchip.com). This web site is used as a means to make files and information easily available to customers. Accessible by using your favorite Internet browser, the web site contains the following information:

- **Product Support** – Data sheets and errata, application notes and sample programs, design resources, user's guides and hardware support documents, latest software releases and archived software
- **General Technical Support** – Frequently Asked Questions (FAQs), technical support requests, online discussion groups, Microchip consultant program member listing
- **Business of Microchip** – Product selector and ordering guides, latest Microchip press releases, listing of seminars and events, listings of Microchip sales offices, distributors and factory representatives

## CUSTOMER SUPPORT

Users of Microchip products can receive assistance through several channels:

- Distributor or Representative
- Local Sales Office
- Field Application Engineer (FAE)
- Technical Support

Customers should contact their distributor, representative or field application engineer (FAE) for support. Local sales offices are also available to help customers. A listing of sales offices and locations is included in the back of this document.

Technical support is available through the web site at: <http://support.microchip.com>.

## DOCUMENT REVISION HISTORY

**Revision A (September 2010)**

- Initial Release of this Document.

# RTD Reference Design

---

NOTES:



---

---

**Chapter 1. Product Overview**

---

---

**1.1 INTRODUCTION**

The following name and assembly number are found on the RTD Reference Design's Printed Circuit Board (PCB):

- 102-00115

**1.2 WHAT IS THE RTD REFERENCE DESIGN?**

The RTD Reference Design demonstrates how to implement a Resistive Temperature Detector (RTD) and accurately measure temperature. This solution uses the MCP3551 22-Bit Analog-to-Digital Converter (ADC) to measure voltage across the RTD. The ADC and the RTD are referenced using an on-board reference voltage, and the ADC inputs are directly connected to the RTD terminals. This provides a ratio metric temperature measurement. The solution uses a current limiting resistor to bias the RTD. It provides a reliable and accurate RTD instrumentation without the need for extensive circuit compensation and calibration routines.

In addition, this reference design includes a silicon temperature sensor, MCP9804. This sensor is used for comparison only, it is not needed for the RTD instrumentation circuit. The MCP3551 and MCP9804 outputs are read using a USB PIC<sup>®</sup> MCU. This controller is also connected to a PC using USB interface. The Thermal Management software is used to plot the RTD temperature data in strip chart format.

**1.3 WHAT THE RTD REFERENCE DESIGN KIT INCLUDES**

This RTD Reference Design Kit includes:

- RTD Reference Design, 102-00115
- USB cable
- Important Information Sheet

# RTD Reference Design

---

NOTES:

---

---

## Chapter 2. Installation and Operation

---

---

### 2.1 INTRODUCTION

The RTD Reference Design demonstrates Microchip's solution to accurately measure temperature using a 22-bit ADC, MCP3551. This solution eliminates the need for the traditional analog instrumentation system calibration or gain and offset trimming techniques. In addition, the effect of self-heat can be minimized by limiting the RTD biasing current using a single resistor.

This reference design uses the technique described in Application Note AN1154 - "*Precision RTD Instrumentation for Temperature Sensing*" (DS01154). The RTD Reference Design allows users to evaluate Microchip's solution to accurately measure temperature using an RTD. RTD resistance availability typically ranges from 100 $\Omega$  to 5000 $\Omega$ . When biasing an RTD to measure temperature, self-heat due to power dissipation has to be considered. In order to output measurable voltage across the RTD for wide temperature range, the biasing current has to be relatively high. This causes higher power dissipation through heat and skews the temperature reading. This solution uses a ratiometric technique between the RTD resistance and the ADC resolution to achieve high accuracy throughout the entire sensor range.

This solution uses an on-board (local) surface mount RTD and an external RTD. The local and external RTDs are selected using JP2. The MCP9804 temperature sensor is also used to measure local temperature.

The MCP3551 and the MCP9804 serial output lines are connected to a PIC MCU. RTD linearization is computed with the microcontroller. This controller communicates with a PC via the USB interface. The temperature data is then displayed on the PC using the Thermal Management software in strip chart format.

### 2.2 FEATURES

The RTD Reference Design has the following features:

- Surface mount PT100 RTD
- External RTD connector (not included)
- Thermal Management GUI
- 22-Bit ADC MCP3551
- $\pm 1^{\circ}\text{C}$  Maximum accuracy temperature sensor MCP9804
- PIC18F2550 microcontroller
- USB interface to PC

# RTD Reference Design

## 2.3 GETTING STARTED

This section describes how to quickly configure the RTD Reference Design. A simplified block diagram of the configuration is provided in Figure 2-1.

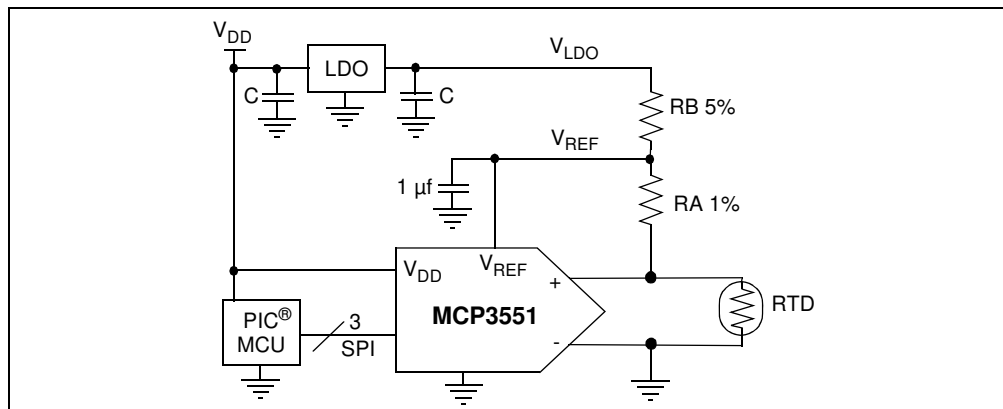

**FIGURE 2-1:** RTD Reference Design Simplified Block Diagram.

### 2.3.1 Hardware Setup

1. Connect the USB cable to PC
2. Select JP2 for Local/External RTD
3. Start the Thermal Management software

### 2.3.2 Software Setup

Once the USB interface is secured, start the Thermal Management Software. When the software starts, if the hardware is successfully detected, the GUI will be displayed (Figure 2-2).

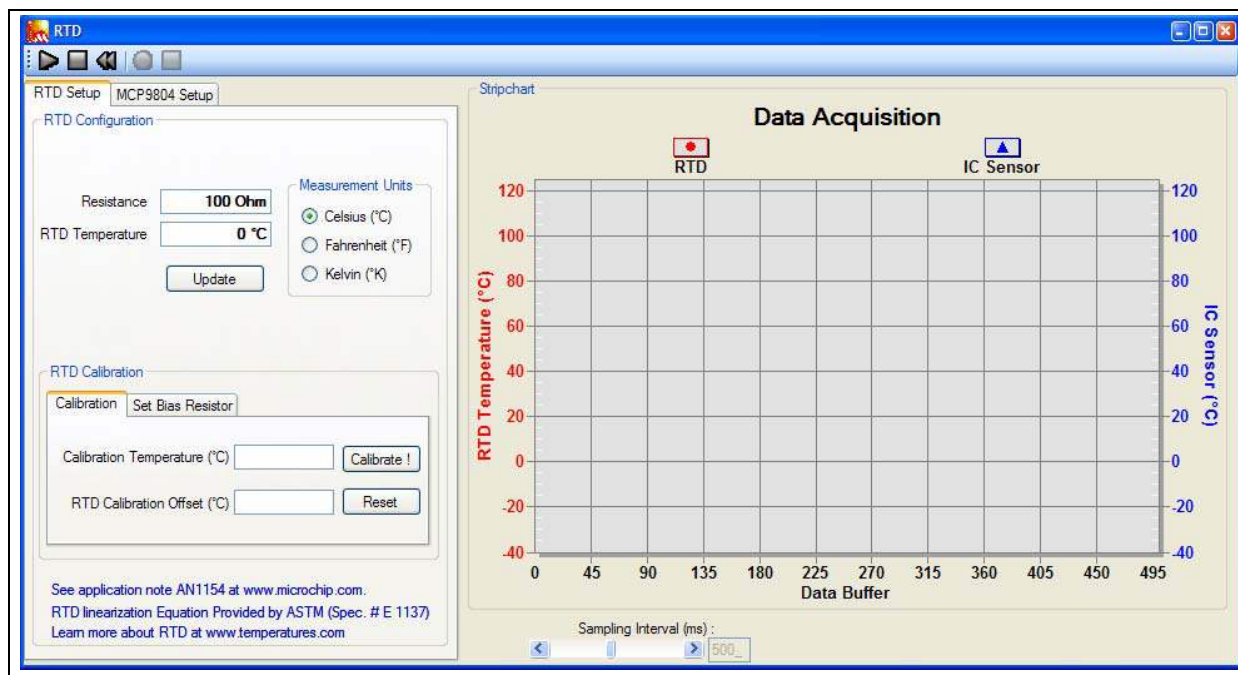
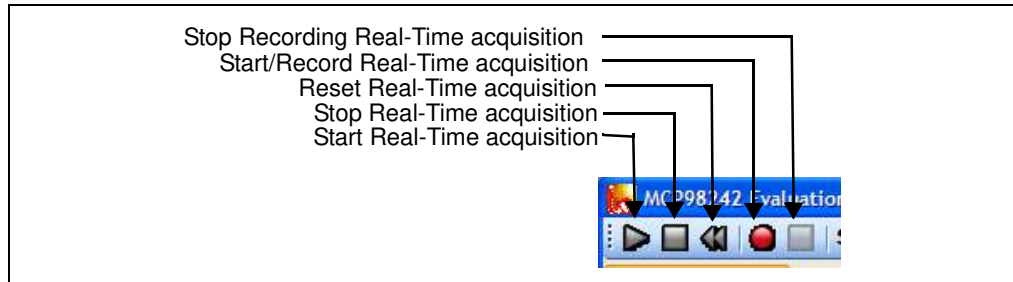

**FIGURE 2-2:** RTD Reference Design GUI.

# Installation and Operation

This configuration window allows the user to set some parameters, such as measurement unit and calibration temperature.

The **Play**, **Stop**, and **Reset** icons (Figure 2-3) can be used to perform a continuous data-log. The **Record** icon enables the user to data-log to an external file. The logging interval can be adjusted using the Interval Scroll bar from 100 ms to 30s.



**FIGURE 2-3:** Real-Time Acquisition.

The RTD temperature is linearized using ASTM specification #E 1137. The linearization is implemented in the PIC MCU.

The Data Acquisition charting tool can be customized by double-clicking the chart, as shown in Figure 2-4. Additional options are available by right-clicking the chart. The user can also zoom into a specific plot range by clicking and dragging the section. The data in the chart can also be exported using the **Export** button.

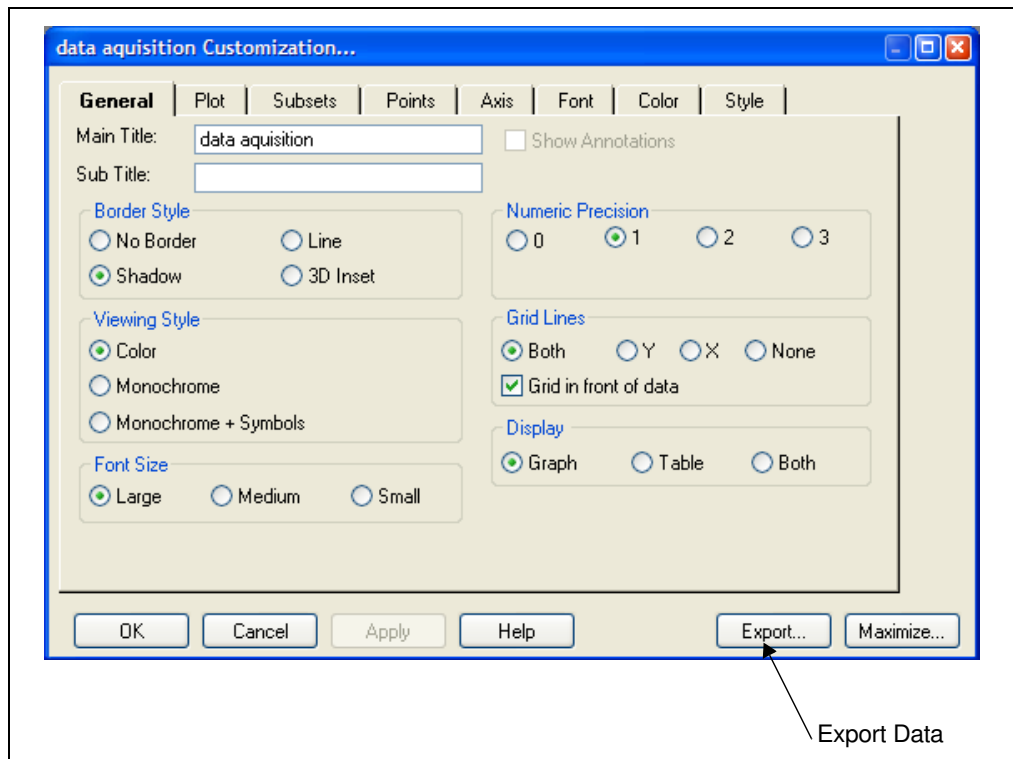

**FIGURE 2-4:** Chart Setup Options.

# RTD Reference Design

## 2.3.3 Sensor Calibration

### 2.3.3.1 RTD SETUP

The RTD sensor can be calibrated using the GUI. Once the RTD is exposed to the dies calibration temperature, simply type in the temperature in the Calibration Temperature field and click the **Calibrate** button. When the temperature is calibrated and the calibration offset is stored in the PIC MCU EEPROM, the calibration offset is displayed in the RTD Calibration Offset text box. The **Reset** button resets the calibration offset to “0”.

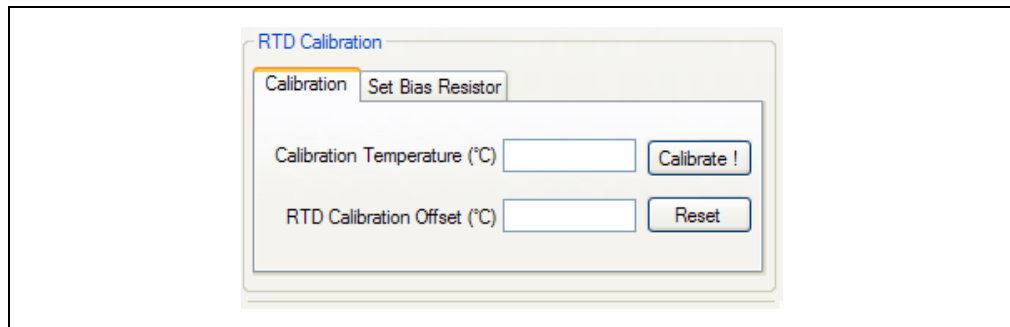

**FIGURE 2-5:** Sensor Calibration.

The GUI also enables users to set the RTD biasing resistor value,  $R_9$ . If a resistor other than a  $100\Omega$  RTD resistor is connected, then replace  $R_9$  (for operation and details refer to the AN1154). The **Reset** button sets  $R_9$  to the default value of  $6800\Omega$ .

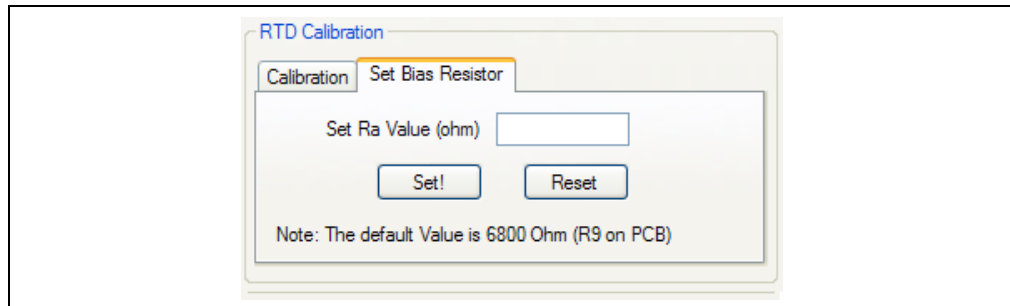

**FIGURE 2-6:** Setting RTD Biasing Resistor.

## 2.3.3.2 MCP9804 SETUP

The MCP9804 is a silicon temperature sensor which measures temperature with  $\pm 0.25^{\circ}\text{C}$  nominal and  $\pm 1^{\circ}\text{C}$  maximum accuracy from  $-40^{\circ}\text{C}$  to  $+125^{\circ}\text{C}$ . This sensor has multiple user programmable features such as Alert Output limits, output hysteresis and mode (see Figure 2-7). The output mode can be set up as either comparator or interrupt output with an active-high or active-low levels. The temperature measurement resolution can also be set up.

The screenshot displays the 'MCP9804 Setup' web interface. It features several configuration sections:

- MCP9804 Configuration:**
  - Hysteresis:** Radio buttons for 0°C (selected), 1.5°C, 3°C, and 6°C.
  - Resolution:** Radio buttons for 0.5°C (selected), 0.25°C, 0.125°C, and 0.0625°C.
  - Conversion:** Radio buttons for Continuous (selected) and Shutdown.
- Alert Output Control:**
  - Enable Alert Pin
  - Alert Mode:** Radio buttons for Comparator (selected) and Interrupt.
  - Alert Polarity:** Radio buttons for Active High and Active Low (selected).
  - Buttons for De.Assert and Int. Clear.
  - Alert output for critical Limit Only
- Temp. Limit Lock:**
  - Tcritical Lock
  - Twindow Lock
  - Reset device Vdd to clear this option
- Registers:**
  - Enable Sensor
  - Update Registers button
  - Capability: 0x00
  - Resolution: 0x0
  - Config: 0x00
  - Temp.: 0 °C
  - Tupper: 0 °C
  - Tlower: 0 °C
  - Tcritical: 0 °C
  - Manu ID: 0x00
  - DevID/Rev: 0x00

**FIGURE 2-7:** MCP9804 Setup.

# RTD Reference Design

---

NOTES:



**Appendix A. Schematic and Layouts**

---

---

**A.1 INTRODUCTION**

This appendix contains the following schematics and layouts for the RTD Reference Design:

- Board – Schematic
- Board – Top Silk and Pads
- Board – Top Layer
- Board – Bottom Silk and Pads
- Board – Bottom Layer



## A.3 BOARD - TOP SILK AND PADS

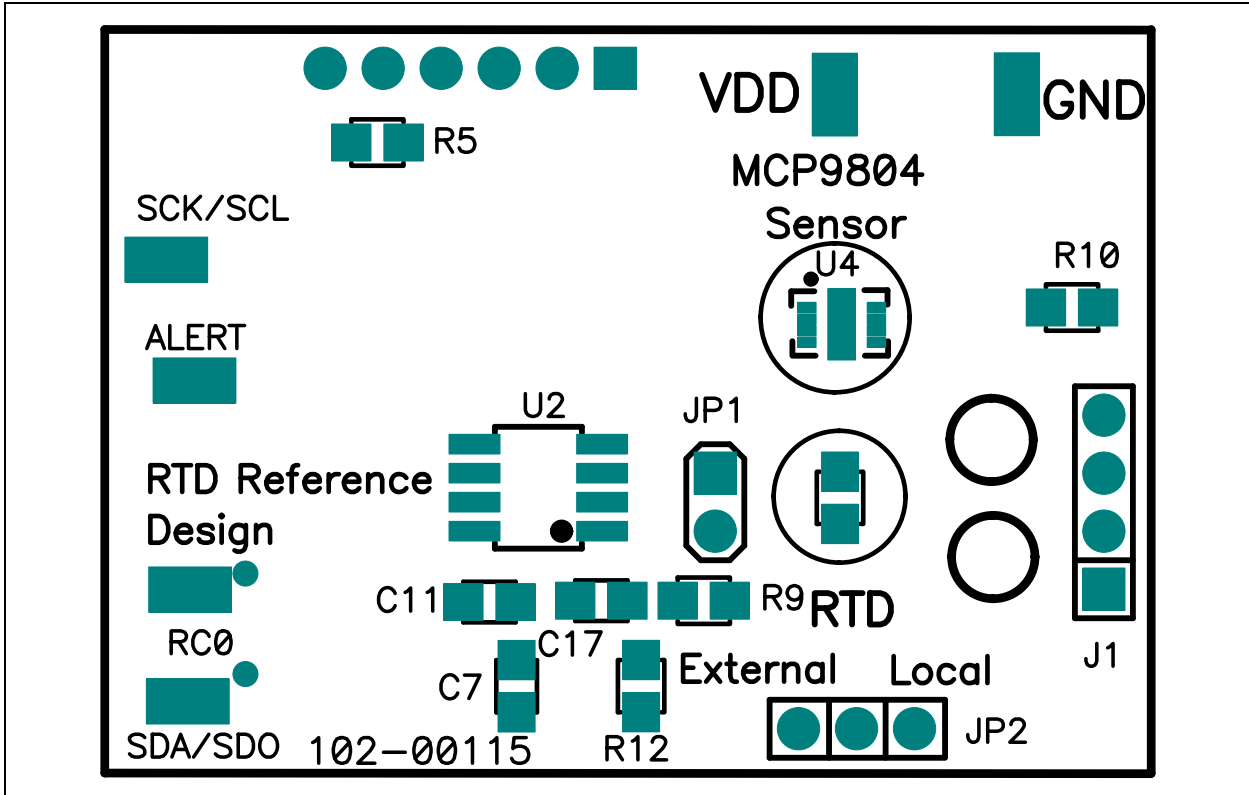

## A.4 BOARD - TOP LAYER

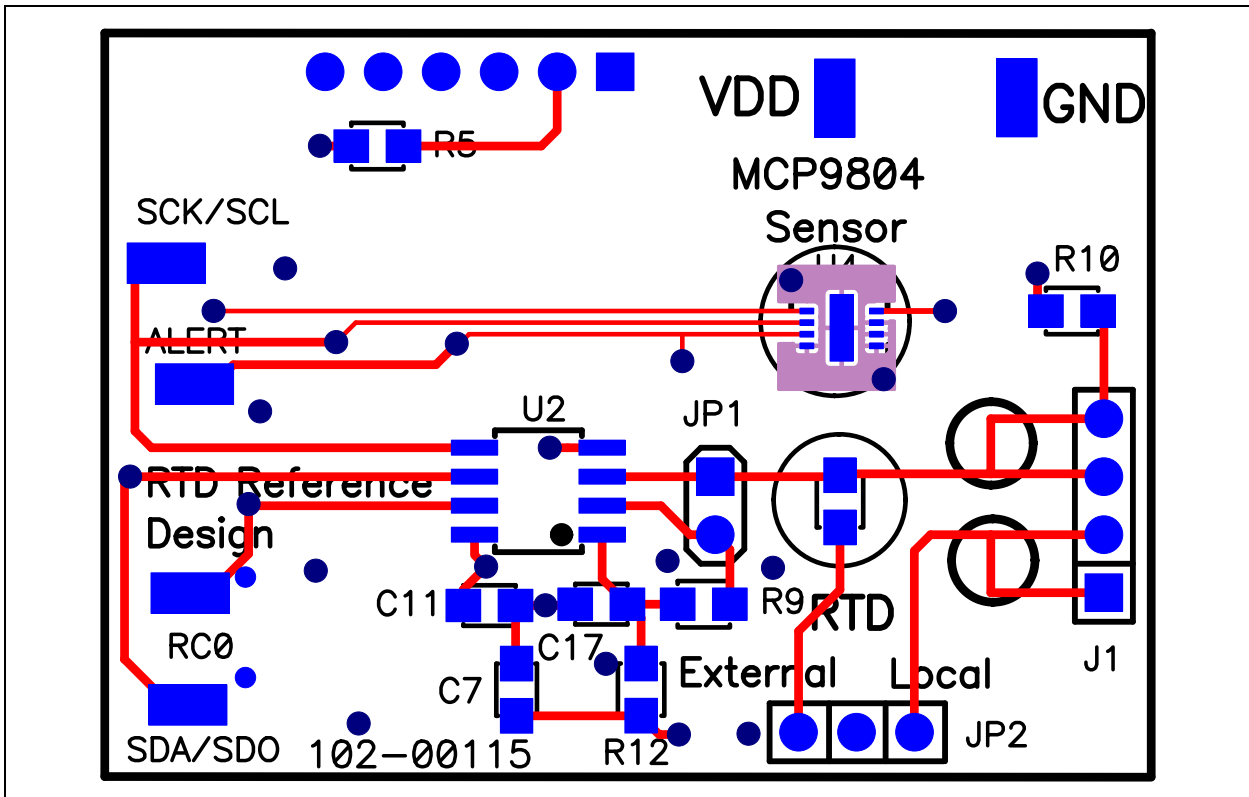

# RTD Reference Design

## A.5 BOARD - BOTTOM SILK AND PADS

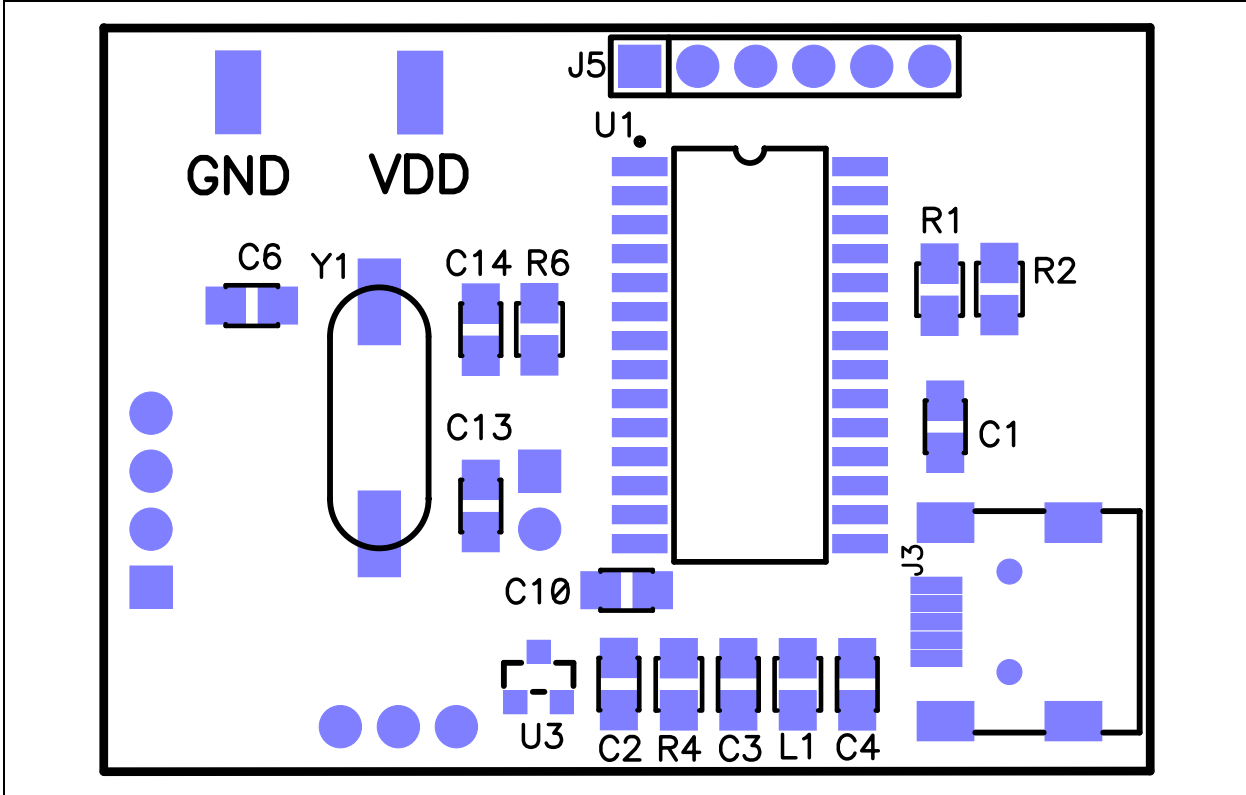

## A.6 BOARD - BOTTOM LAYER

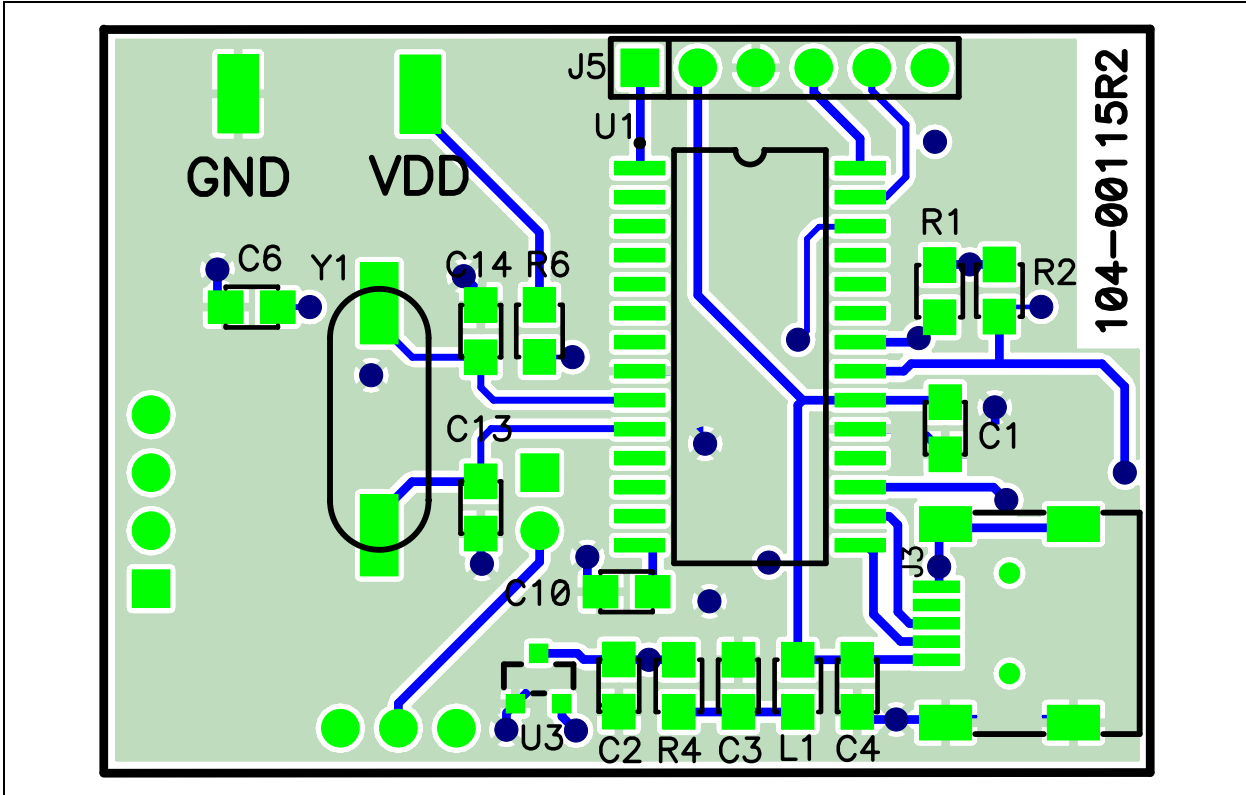

**Appendix B. Bill of Materials**
**TABLE B-1: BILL OF MATERIALS**

Qty	Reference	Description	Manufacturer	Part Number
4	C1, C6, C11, C17	CAP .1UF 25V CERAMIC X7R 0805	Panasonic® - ECG	ECJ-2VB1E104K
2	C2, C7	CAP 1.0UF 16V CERAMIC X7R 0805	Kemet® Electronics	C0805C105K4RACTU
2	C3, C4	CAP 10UF 10V CERAMIC F 0805	Panasonic - ECG	ECJ-2FF1A106Z
1	C10	CAP .47UF 16V CERAMIC X7R 0805	Panasonic - ECG	ECJ-2YB1C474K
2	C13, C14	CAP 22PF 50V CERM CHIP 0805 SMD	Panasonic - ECG	ECJ-2VC1H220J
1	J2	CONN TERM BLOCK 2.54MM 4POS	Phoenix Contact	1725672
1	J3	CONN MINI USB RCPT RA TYPE B SMD	Tyco Electronics	1734035-2
1	J5	DO NOT POPULATE HEADER 1X6	—	—
1	JP1	DO NOT POPULATE SHUNT ECONOMY 2POS .100 TIN	Tyco® Electronics/Amp	2-382811-1
1	JP1	DO NOT POPULATE CONN HEADER VERT 2POS .100 TIN	Tyco Electronics/Amp	3-644695-2
1	JP2	CONN HEADER VERT 2POS .100 TIN	Tyco Electronics/Amp	3-644695-2
1/16 <sup>2</sup>	JP2	3 POS Jumper Switch	ITW® Pancon	JSC416G0
1	L1	INDUCTOR 10UH 100MA 0805	Murata Electronics®	LQM21FN100M70L
1	PCB	RoHS Compliant Bare PCB, RTD Reference Board	Microchip Technology Inc.	104-000115
3	R1, R2, R6	RES 10.0K OHM 1/8W 1% 0805 SMD	Panasonic - ECG	ERJ-6ENF1002V
1	R4	RES 1.0 OHM 1/8W 1% 0805 SMD	Panasonic - ECG	ERJ-6RQF1R0V
2	R9, R12	RES 6.8K OHM 1/10W .1% 0805 SMD	Panasonic - ECG	ERA-6YEB682V
1	R10	RES 0.0 OHM 1/8W 5% 0805 SMD	Panasonic - ECG	ERJ-6GEY0R00V
1	R11	PLATINUM RTD CHIP TEMPERATURE SENSOR SMD (RTD)	ENERCORP Instruments Ltd.	PCS 1.1503.1
8	TP1-TP8	TEST POINT PC COMPACT SMT	Keystone Electronics®	5016
1	U1	28/40/44-Pin, High-Performance, Enhanced Flash, USB Microcontrollers with nanoWatt Technology	Microchip Technology Inc.	PIC18F2550-I/SO
1	U2	IC ADC 22 BIT 2.7V 1 CH SPI 8SOIC	Microchip Technology Inc.	MCP3551-E/SN
1	U3	Low Dropout Positive Voltage Regulator	Microchip Technology Inc.	MCP1701T-5002I/CB
1	U4	2-Wire High-Accuracy Temperature Sensor	Microchip Technology Inc.	MCP9804T-E/MC
1	Y1	CRYSTAL 20.0000 MHZ SERIES SMT	CTS® Electronic Components	ATS200SM

**Note 1:** The components listed in this Bill of Materials are representative of the PCB assembly. The released BOM used in manufacturing uses all RoHS-compliant components.

**2:** Jumper switch comes in strips of 16 switches. Cut individual jumper switch as needed.



## WORLDWIDE SALES AND SERVICE

### AMERICAS

**Corporate Office**  
2355 West Chandler Blvd.  
Chandler, AZ 85224-6199  
Tel: 480-792-7200  
Fax: 480-792-7277  
Technical Support:  
<http://support.microchip.com>  
Web Address:  
[www.microchip.com](http://www.microchip.com)

**Atlanta**  
Duluth, GA  
Tel: 678-957-9614  
Fax: 678-957-1455

**Boston**  
Westborough, MA  
Tel: 774-760-0087  
Fax: 774-760-0088

**Chicago**  
Itasca, IL  
Tel: 630-285-0071  
Fax: 630-285-0075

**Cleveland**  
Independence, OH  
Tel: 216-447-0464  
Fax: 216-447-0643

**Dallas**  
Addison, TX  
Tel: 972-818-7423  
Fax: 972-818-2924

**Detroit**  
Farmington Hills, MI  
Tel: 248-538-2250  
Fax: 248-538-2260

**Kokomo**  
Kokomo, IN  
Tel: 765-864-8360  
Fax: 765-864-8387

**Los Angeles**  
Mission Viejo, CA  
Tel: 949-462-9523  
Fax: 949-462-9608

**Santa Clara**  
Santa Clara, CA  
Tel: 408-961-6444  
Fax: 408-961-6445

**Toronto**  
Mississauga, Ontario,  
Canada  
Tel: 905-673-0699  
Fax: 905-673-6509

### ASIA/PACIFIC

**Asia Pacific Office**  
Suites 3707-14, 37th Floor  
Tower 6, The Gateway  
Harbour City, Kowloon  
Hong Kong  
Tel: 852-2401-1200  
Fax: 852-2401-3431

**Australia - Sydney**  
Tel: 61-2-9868-6733  
Fax: 61-2-9868-6755

**China - Beijing**  
Tel: 86-10-8528-2100  
Fax: 86-10-8528-2104

**China - Chengdu**  
Tel: 86-28-8665-5511  
Fax: 86-28-8665-7889

**China - Chongqing**  
Tel: 86-23-8980-9588  
Fax: 86-23-8980-9500

**China - Hong Kong SAR**  
Tel: 852-2401-1200  
Fax: 852-2401-3431

**China - Nanjing**  
Tel: 86-25-8473-2460  
Fax: 86-25-8473-2470

**China - Qingdao**  
Tel: 86-532-8502-7355  
Fax: 86-532-8502-7205

**China - Shanghai**  
Tel: 86-21-5407-5533  
Fax: 86-21-5407-5066

**China - Shenyang**  
Tel: 86-24-2334-2829  
Fax: 86-24-2334-2393

**China - Shenzhen**  
Tel: 86-755-8203-2660  
Fax: 86-755-8203-1760

**China - Wuhan**  
Tel: 86-27-5980-5300  
Fax: 86-27-5980-5118

**China - Xian**  
Tel: 86-29-8833-7252  
Fax: 86-29-8833-7256

**China - Xiamen**  
Tel: 86-592-2388138  
Fax: 86-592-2388130

**China - Zhuhai**  
Tel: 86-756-3210040  
Fax: 86-756-3210049

### ASIA/PACIFIC

**India - Bangalore**  
Tel: 91-80-3090-4444  
Fax: 91-80-3090-4123

**India - New Delhi**  
Tel: 91-11-4160-8631  
Fax: 91-11-4160-8632

**India - Pune**  
Tel: 91-20-2566-1512  
Fax: 91-20-2566-1513

**Japan - Yokohama**  
Tel: 81-45-471- 6166  
Fax: 81-45-471-6122

**Korea - Daegu**  
Tel: 82-53-744-4301  
Fax: 82-53-744-4302

**Korea - Seoul**  
Tel: 82-2-554-7200  
Fax: 82-2-558-5932 or  
82-2-558-5934

**Malaysia - Kuala Lumpur**  
Tel: 60-3-6201-9857  
Fax: 60-3-6201-9859

**Malaysia - Penang**  
Tel: 60-4-227-8870  
Fax: 60-4-227-4068

**Philippines - Manila**  
Tel: 63-2-634-9065  
Fax: 63-2-634-9069

**Singapore**  
Tel: 65-6334-8870  
Fax: 65-6334-8850

**Taiwan - Hsin Chu**  
Tel: 886-3-6578-300  
Fax: 886-3-6578-370

**Taiwan - Kaohsiung**  
Tel: 886-7-213-7830  
Fax: 886-7-330-9305

**Taiwan - Taipei**  
Tel: 886-2-2500-6610  
Fax: 886-2-2508-0102

**Thailand - Bangkok**  
Tel: 66-2-694-1351  
Fax: 66-2-694-1350

### EUROPE

**Austria - Wels**  
Tel: 43-7242-2244-39  
Fax: 43-7242-2244-393

**Denmark - Copenhagen**  
Tel: 45-4450-2828  
Fax: 45-4485-2829

**France - Paris**  
Tel: 33-1-69-53-63-20  
Fax: 33-1-69-30-90-79

**Germany - Munich**  
Tel: 49-89-627-144-0  
Fax: 49-89-627-144-44

**Italy - Milan**  
Tel: 39-0331-742611  
Fax: 39-0331-466781

**Netherlands - Drunen**  
Tel: 31-416-690399  
Fax: 31-416-690340

**Spain - Madrid**  
Tel: 34-91-708-08-90  
Fax: 34-91-708-08-91

**UK - Wokingham**  
Tel: 44-118-921-5869  
Fax: 44-118-921-5820