

April 1995

8A, 400V - 600V Hyperfast Diodes

Features

- Hyperfast with Soft Recovery <30ns
- Operating Temperature +175°C
- Reverse Voltage Up To 600V
- Avalanche Energy Rated
- Planar Construction

Applications

- Switching Power Supplies
- Power Switching Circuits
- General Purpose

Description

RHRP840, RHRP850 and RHRP860 (TA49059) are hyperfast diodes with soft recovery characteristics ($t_{RR} < 30ns$). They have half the recovery time of ultrafast diodes and are silicon nitride passivated ion-implanted epitaxial planar construction.

These devices are intended for use as freewheeling/clamping diodes and rectifiers in a variety of switching power supplies and other power switching applications. Their low stored charge and hyperfast soft recovery minimize ringing and electrical noise in many power switching circuits reducing power loss in the switching transistors.

PACKAGING AVAILABILITY

PART NUMBER	PACKAGE	BRAND
RHRP840	TO-220AC	RHRP840
RHRP850	TO-220AC	RHRP850
RHRP860	TO-220AC	RHRP860

NOTE: When ordering, use the entire part number.

Package

JEDEC TO-220AC

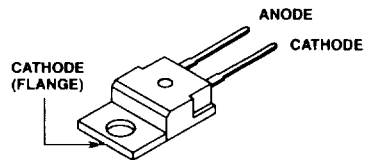

Symbol



Absolute Maximum Ratings $T_C = +25^\circ C$, Unless Otherwise Specified

	RHRP840	RHRP850	RHRP860	UNITS
Peak Repetitive Reverse Voltage V_{RRM}	400	500	600	V
Working Peak Reverse Voltage V_{RWM}	400	500	600	V
DC Blocking Voltage V_R	400	500	600	V
Average Rectified Forward Current $I_{F(AV)}$ ($T_C = +150^\circ C$)	8	8	8	A
Repetitive Peak Surge Current I_{FSM} (Square Wave, 20kHz)	16	16	16	A
Nonrepetitive Peak Surge Current I_{FSM} (Halfwave, 1 Phase, 60Hz)	100	100	100	A
Maximum Power Dissipation P_D	75	75	75	W
Avalanche Energy ($L = 40mH$) E_{AVL}	20	20	20	mJ
Operating and Storage Temperature T_{STG}, T_J	-65 to +175	-65 to +175	-65 to +175	$^\circ C$

Specifications RHRP840, RHRP850, RHRP860

Electrical Specifications $T_C = +25^\circ\text{C}$, Unless Otherwise Specified

SYMBOL	TEST CONDITION	RHRP840			RHRP850			RHRP860			UNITS
		MIN	TYP	MAX	MIN	TYP	MAX	MIN	TYP	MAX	
V_F	$I_F = 8\text{A}, T_C = +25^\circ\text{C}$	-	-	2.1	-	-	2.1	-	-	2.1	V
	$I_F = 8\text{A}, T_C = +150^\circ\text{C}$	-	-	1.7	-	-	1.7	-	-	1.7	V
I_R	$V_R = 400\text{V}, T_C = +25^\circ\text{C}$	-	-	100	-	-	-	-	-	-	μA
	$V_R = 500\text{V}, T_C = +25^\circ\text{C}$	-	-	-	-	-	100	-	-	-	μA
	$V_R = 600\text{V}, T_C = +25^\circ\text{C}$	-	-	-	-	-	-	-	-	100	μA
I_R	$V_R = 400\text{V}, T_C = +150^\circ\text{C}$	-	-	500	-	-	-	-	-	-	μA
	$V_R = 500\text{V}, T_C = +150^\circ\text{C}$	-	-	-	-	-	500	-	-	-	μA
	$V_R = 600\text{V}, T_C = +150^\circ\text{C}$	-	-	-	-	-	-	-	-	500	μA
t_{RR}	$I_F = 1\text{A}, dI_F/dt = 100\text{A}/\mu\text{s}$	-	-	30	-	-	30	-	-	30	ns
	$I_F = 8\text{A}, dI_F/dt = 100\text{A}/\mu\text{s}$	-	-	35	-	-	35	-	-	35	ns
t_A	$I_F = 8\text{A}, dI_F/dt = 100\text{A}/\mu\text{s}$	-	16	-	-	16	-	-	16	-	ns
t_B	$I_F = 8\text{A}, dI_F/dt = 100\text{A}/\mu\text{s}$	-	11	-	-	11	-	-	11	-	ns
Q_{RR}	$I_F = 8\text{A}, dI_F/dt = 100\text{A}/\mu\text{s}$	-	26	-	-	26	-	-	26	-	nC
C_J	$V_R = 10\text{V}, I_F = 0\text{A}$	-	25	-	-	25	-	-	25	-	pF
$R_{\theta JC}$		-	-	2	-	-	2	-	-	2	$^\circ\text{C}/\text{W}$

DEFINITIONS

V_F = Instantaneous forward voltage ($p_w = 300\mu\text{s}$, $D = 2\%$).

I_R = Instantaneous reverse current.

t_{RR} = Reverse recovery time (See Figure 2), summation of $t_A + t_B$.

t_A = Time to reach peak reverse current (See Figure 2).

t_B = Time from peak I_{RM} to projected zero crossing of I_{RM} based on a straight line from peak I_{RM} through 25% of I_{RM} (See Figure 2).

$R_{\theta JC}$ = Thermal resistance junction to case.

E_{AVL} = Controlled avalanche energy (See Figure 10 and Figure 11).

p_w = Pulse width.

D = Duty cycle.

V_1 AMPLITUDE CONTROLS I_F
 V_2 AMPLITUDE CONTROLS dI_F/dt
 L_1 = SELF INDUCTANCE OF
 $R_4 + L_{\text{LOOP}}$

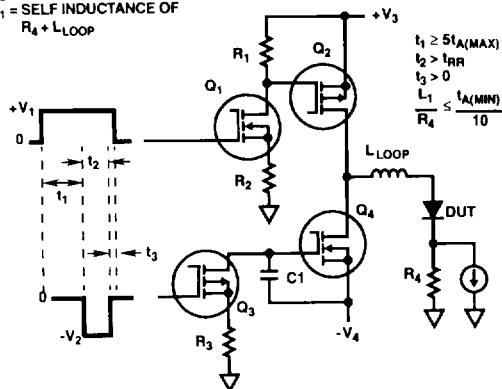

FIGURE 1. t_{RR} TEST CIRCUIT

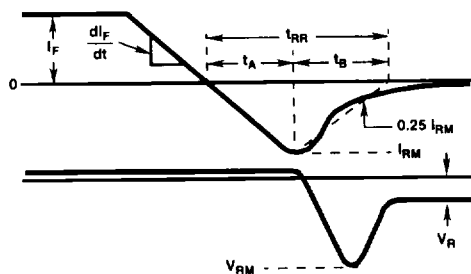

FIGURE 2. t_{RR} WAVEFORMS AND DEFINITIONS

Typical Performance Curves

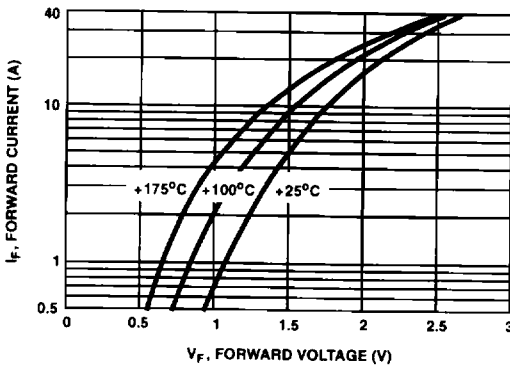

FIGURE 3. TYPICAL FORWARD CURRENT vs FORWARD VOLTAGE DROP

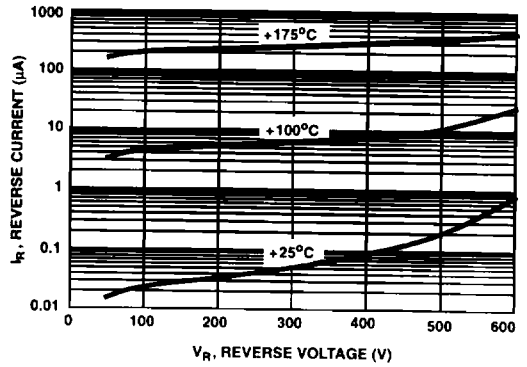

FIGURE 4. TYPICAL REVERSE CURRENT vs REVERSE VOLTAGE

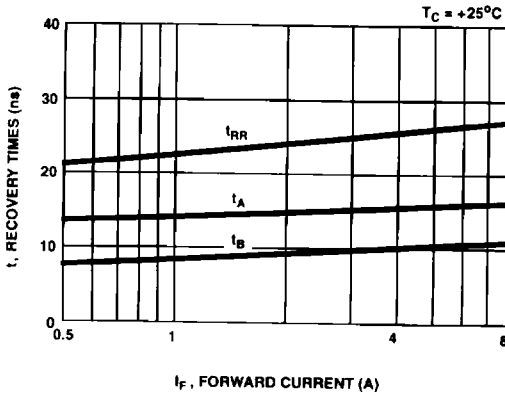

FIGURE 5. TYPICAL t_{RR} , t_A AND t_B CURVES vs FORWARD CURRENT AT +25°C

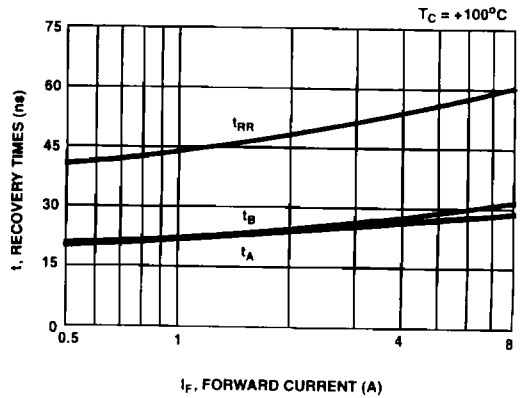

FIGURE 6. TYPICAL t_{RR} , t_A AND t_B CURVES vs FORWARD CURRENT AT +100°C

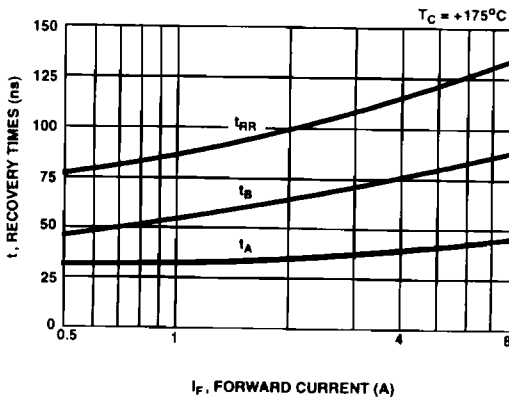

FIGURE 7. TYPICAL t_{RR} , t_A AND t_B CURVES vs FORWARD CURRENT AT +175°C

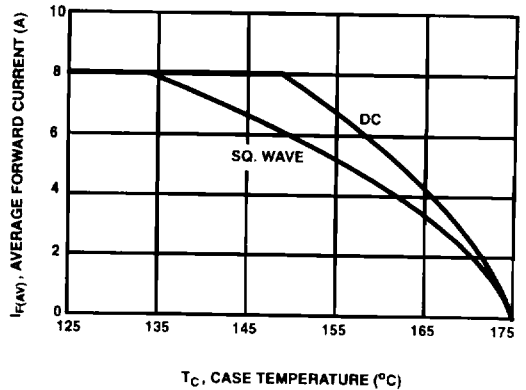

FIGURE 8. CURRENT DERATING CURVE FOR ALL TYPES

Typical Performance Curves (Continued)

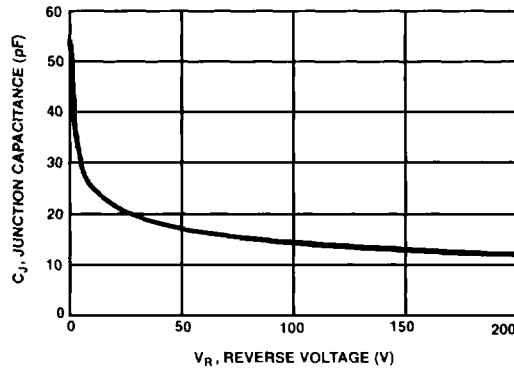

FIGURE 9. TYPICAL JUNCTION CAPACITANCE vs REVERSE VOLTAGE

$I_{MAX} = 1A$
 $L = 40mH$
 $R < 0.1\Omega$
 $E_{AVL} = 1/2LI^2[V_{AVL}/(V_{AVL} - V_{DD})]$
 Q1 AND Q2 ARE 1000V MOSFETS

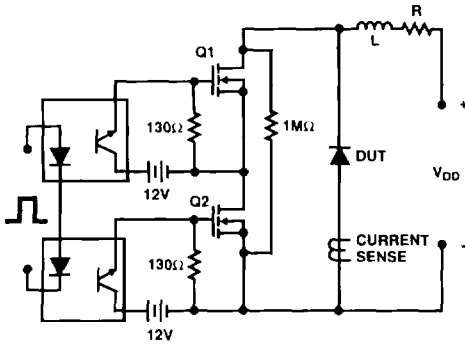

FIGURE 10. AVALANCHE ENERGY TEST CIRCUIT

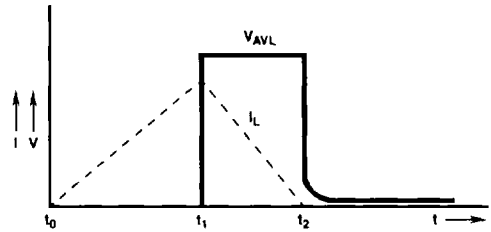

FIGURE 11. AVALANCHE CURRENT AND VOLTAGE WAVEFORMS