

IS61WV51216EEALL IS61/64WV51216EEBLL

AUGUST 2019

512Kx16 HIGH SPEED ASYNCHRONOUS CMOS STATIC RAM with ECC

KEY FEATURES

- High-speed access time: 8ns, 10ns, 20ns
- Single power supply
 - 1.65V-2.2V V_{DD} (IS61WV51216EEALL)
 - 2.4V-3.6V V_{DD} (IS61/64WV51216EEBLL)
- Error Detection and Correction with optional ERR1/ERR2 output pin:
 - ERR1 pin indicates 1-bit error detection and correction.
 - ERR2 pin indicates 2-bit error detection
- Package Available:
 - 44-pin TSOP (Type II)
 - 48-pin TSOP (Type I)
 - 48-ball mini BGA (6mm x 8mm)
 - 54 pin TSOP (Type II)
- Three state outputs
- Industrial and Automotive temperature support
- Lead-free available

DESCRIPTION

The ISSI IS61/64WV51216EEALL/BLL are high-speed, low power, 8M bit static RAMs organized as 512K words by 16 bits. It is fabricated using ISSI's high-performance CMOS technology and implemented ECC function to improve reliability.

This highly reliable process coupled with innovative circuit design techniques including ECC (SEC-DED: Single Error Correcting-Double Error Detecting) yield high-performance and highly reliable devices.

When CS# is HIGH (deselected), the device assumes a standby mode at which the power dissipation can be reduced down with CMOS input levels.

Easy memory expansion is provided by using Chip Enable and Output Enable inputs. The active LOW Write Enable (WE#) controls both writing and reading of the memory.

A data byte allows Upper Byte (UB#) and Lower Byte (LB#) access.

The devices are packaged in the JEDEC standard 44-pin TSOP (TYPE II), 48-pin mini BGA (6mm x 8mm), 48-pin TSOP (TYPE I), and 54-pin TSOP (TYPE II)

FUNCTIONAL BLOCK DIAGRAM

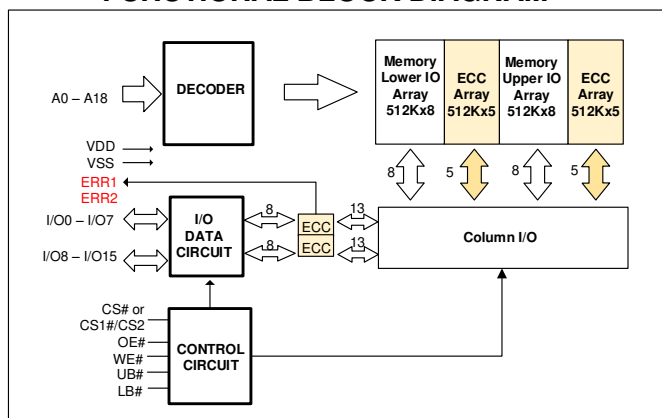

Copyright © 2019 Integrated Silicon Solution, Inc. All rights reserved. ISSI reserves the right to make changes to this specification and its products at any time without notice. ISSI assumes no liability arising out of the application or use of any information, products or services described herein. Customers are advised to obtain the latest version of this device specification before relying on any published information and before placing orders for products.

Integrated Silicon Solution, Inc. does not recommend the use of any of its products in life support applications where the failure or malfunction of the product can reasonably be expected to cause failure of the life support system or to significantly affect its safety or effectiveness. Products are not authorized for use in such applications unless Integrated Silicon Solution, Inc. receives written assurance to its satisfaction, that:

- a.) the risk of injury or damage has been minimized;
- b.) the user assume all such risks; and
- c.) potential liability of Integrated Silicon Solution, Inc is adequately protected under the circumstances

PIN CONFIGURATIONS

48-Pin mini BGA(6mm x 8mm)

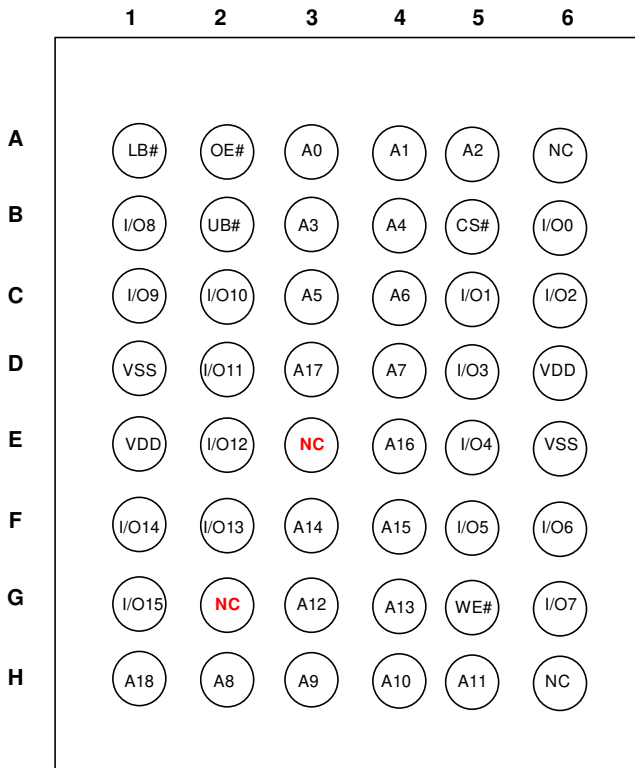

48-Pin mini BGA (6mm x 8mm), ERR1/2

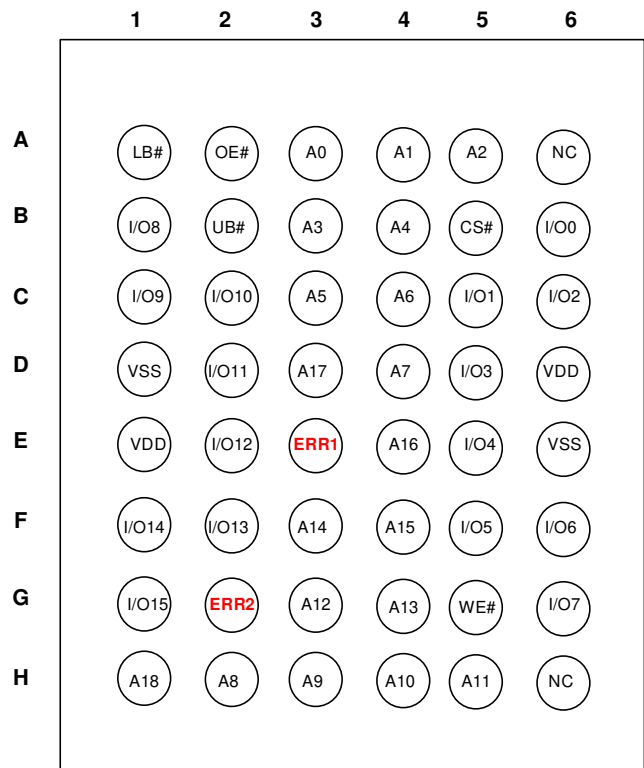

44-Pin TSOP-II

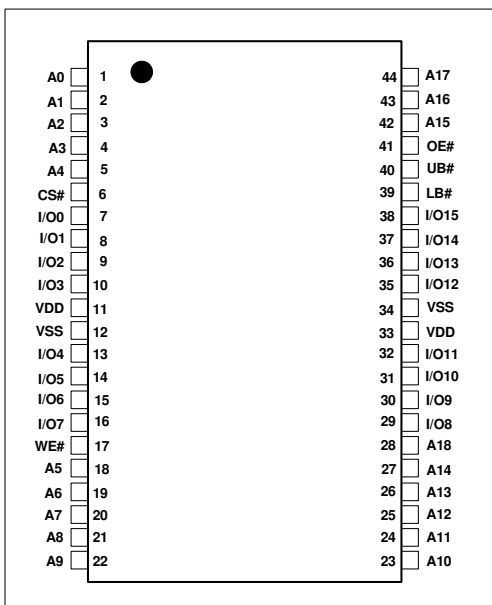

48-Pin TSOP-I, ERR1/ERR2

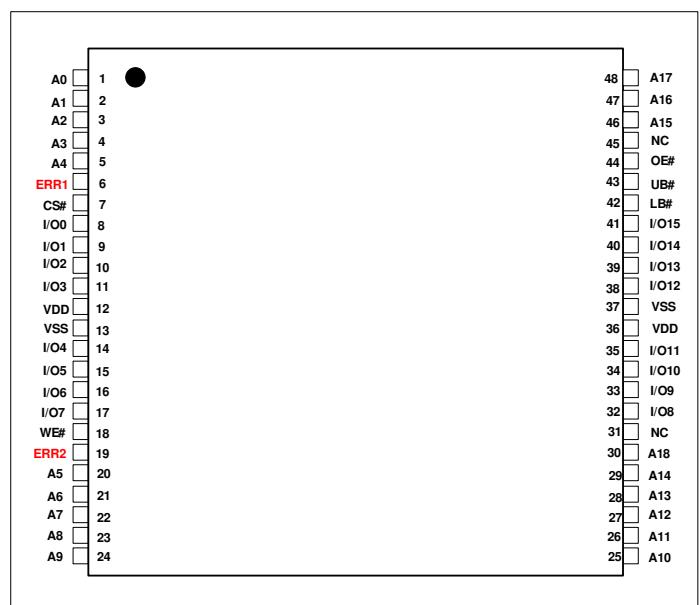

54-Pin TSOP-II

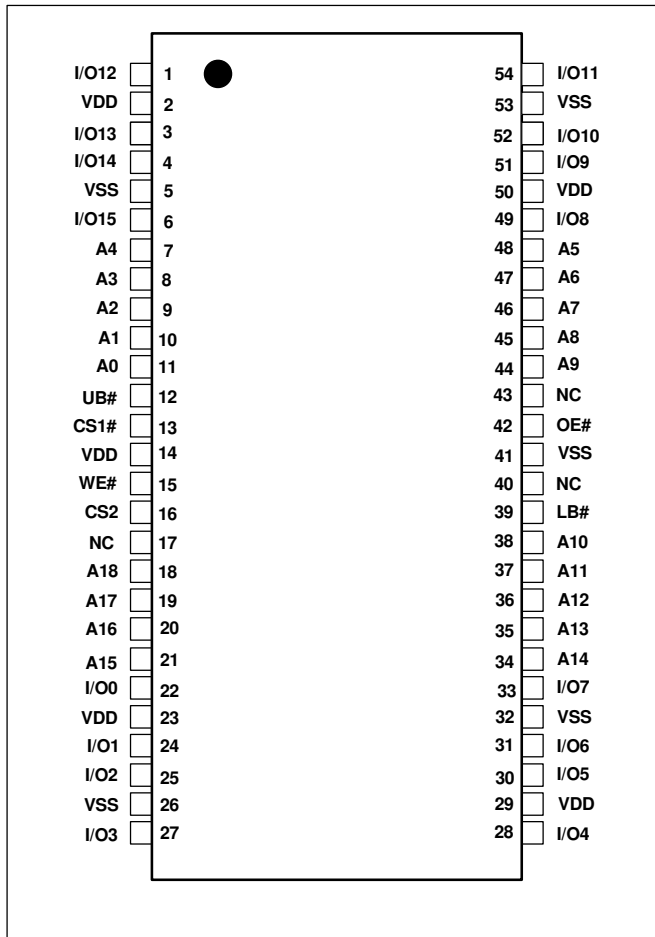

54-Pin TSOP-II, ERR1/ERR2

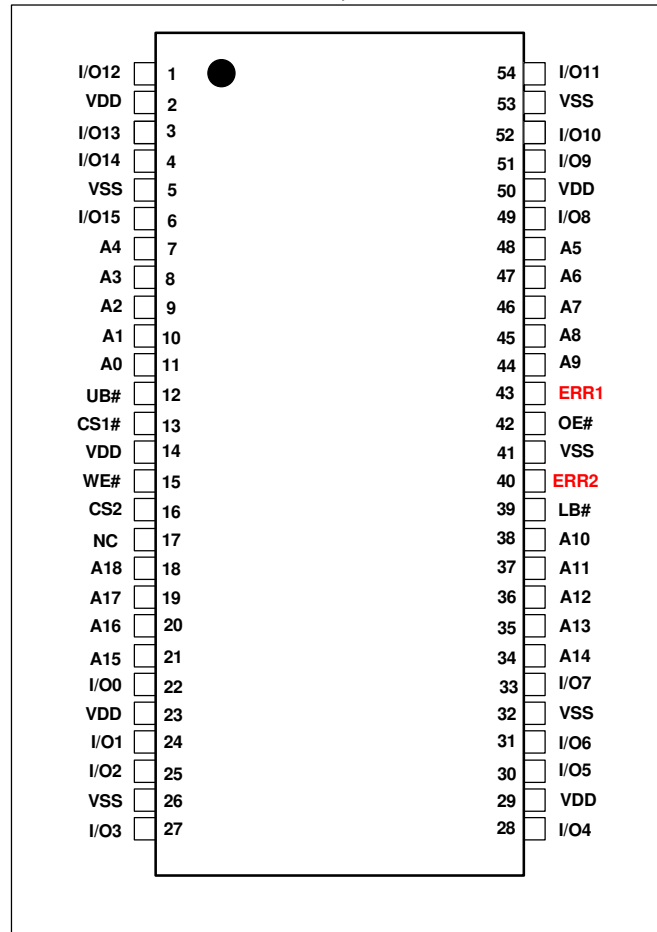

PIN DESCRIPTIONS

A0-A18	Address Inputs
I/O0-I/O15	Data Inputs/Outputs
CS# or CS1#/CS2	Chip Enable Input
OE#	Output Enable Input
WE#	Write Enable Input
LB#	Lower-byte Control (I/O0-I/O7)
UB#	Upper-byte Control (I/O8-I/O15)
ERR1	1-bit Error Detection and Correction Signal
ERR2	2-bit ERR Detection Signal
NC	No Connection
VDD	Power
VSS	Ground

FUNCTION DESCRIPTION

SRAM is one of random access memories. Each byte or word has an address and can be accessed randomly. SRAM has three different modes supported. Each function is described below with Truth Table.

STANDBY MODE

Device enters standby mode when deselected (CS# HIGH). The input and output pins (I/O0-15) are placed in a high impedance state. CMOS input in this mode will maximize saving power.

WRITE MODE

Write operation issues with Chip selected (CS#) and Write Enable (WE#) input LOW. The input and output pins (I/O0-15) are in data input mode. Output buffers are closed during this time even if OE# is LOW. UB# and LB# enables a byte write feature. By enabling LB# LOW, data from I/O pins (I/O0 through I/O7) are written into the location specified on the address pins. And with UB# being LOW, data from I/O pins (I/O8 through I/O15) are written into the location.

READ MODE

Read operation issues with Chip selected (CS# LOW) and Write Enable (WE#) input HIGH. When OE# is LOW, output buffer turns on to make data output. Any input to I/O pins during READ mode is not permitted. UB# and LB# enables a byte read feature. By enabling LB# LOW, data from memory appears on I/O0-7. And with UB# being LOW, data from memory appears on I/O8-15.

In the READ mode, output buffers can be turned off by pulling OE# HIGH. In this mode, internal device operates as READ but I/Os are in a high impedance state. Since device is in READ mode, active current is used.

ERROR DETECTION AND ERROR CORRECTION

- Independent ECC per each byte
 - detect and correct 1-bit error per byte or detect multi-bit error per byte
- Optional ERR1 output signal indicates 1-bit error detection and correction
- Optional ERR2 output signal indicates multi-bit error detection.
- Controller can use either ERR1 or ERR2 to monitor ECC event. Unused pins (ERR1 or ERR2) can be left floating.
- Better reliability than parity code schemes which can only detect an error but not correct an error
- Backward Compatible: Drop in replacement to current in industry standard devices (without ECC)

ERR1, ERR2 OUTPUT SIGNAL BEHAVIOR

ERR1	ERR2	DQ pin	Status	Remark
0	0	Valid Q	No Error	
1	0	Valid Q	1-Bit Error only	1-bit error per byte detected and corrected
0	1	In-Valid Q	Multi-Bit Error only	No 1-bit error. Multi-bit error per byte detected (out of 2 bytes)
1	1	In-Valid Q	1-bit & Multi-bit error	1-bit error detected and corrected at one byte, and multi-bit error detected at another byte.
High-Z	High-Z	Valid D	Non-Read	Write operation or Output Disabled

TRUTH TABLE

Mode	CS#	WE#	OE#	LB#	UB#	I/O0-I/O7	I/O8-I/O15	VDD Current
Not Selected	H	X	X	X	X	High-Z	High-Z	I _{SB1} , I _{SB2}
Output Disabled	L	H	H	L	X	High-Z	High-Z	I _{CC} , I _{CC1}
	L	X	X	H	H	High-Z	High-Z	
Read	L	H	L	L	H	DOUT	High-Z	I _{CC} , I _{CC1}
	L	H	L	H	L	High-Z	DOUT	
	L	H	L	L	L	DOUT	DOUT	
Write	L	L	X	L	H	DIN	High-Z	I _{CC} , I _{CC1}
	L	L	X	H	L	High-Z	DIN	
	L	L	X	L	L	DIN	DIN	

Note:

1. CS# = H means CS1#=HIGH, and CS2= LOW in Dual Chip Select Device.

POWER UP INITIALIZATION

The device includes on-chip voltage sensor used to launch POWER-UP initialization process.

When VDD reaches stable level, the device requires 150us of t_{PU} (Power-Up Time) to complete its self-initialization process.

When initialization is complete, the device is ready for normal operation.

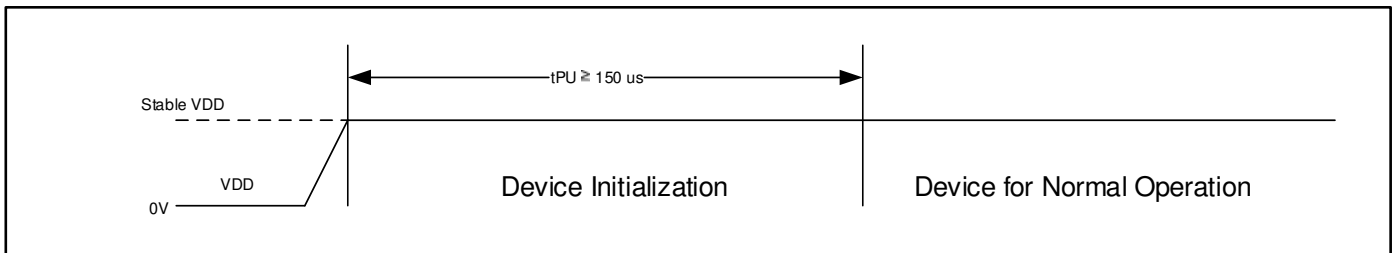

ABSOLUTE MAXIMUM RATINGS AND OPERATING RANGE

ABSOLUTE MAXIMUM RATINGS⁽¹⁾

Symbol	Parameter	Value	Unit
V _{term}	Terminal Voltage with Respect to VSS	-0.5 to V _{DD} + 0.5V	V
V _{DD}	V _{DD} Related to VSS	-0.3 to 4.0	V
t _{Stg}	Storage Temperature	-65 to +150	°C
P _T	Power Dissipation	1.0	W

Note:

1. Stress greater than those listed under ABSOLUTE MAXIMUM RATINGS may cause permanent damage to the device. This is a stress rating only and functional operation of the device at these or any other conditions above those indicated in the operational sections of this specification is not implied. Exposure to absolute maximum rating conditions for extended periods may affect reliability.

PIN CAPACITANCE ⁽¹⁾

Parameter	Symbol	Test Condition	Max	Units
Input capacitance	C _{IN}	T _A = 25°C, f = 1 MHz, V _{DD} = V _{DD} (typ)	6	pF
DQ capacitance (IO0–IO15)	C _{I/O}		8	pF

Note:

1. These parameters are guaranteed by design and tested by a sample basis only.

OPERATING RANGE⁽¹⁾

Range	Ambient Temperature	IS61WV51216EEALL VDD (20ns)	IS61WV51216EEBLL VDD (8, 10ns)	IS64WV51216EEBLL VDD (10ns)
Industrial	-40°C to +85°C	1.65V – 2.2V	2.4V – 3.6V	–
Automotive (A3)	-40°C to +125°C	–	–	2.4V – 3.6V

Note:

1. Full device AC operation assumes a 100 μs ramp time from 0 to V_{DD}(min) and 200 μs wait time after V_{DD} stabilization.

THERMAL CHARACTERISTICS ⁽¹⁾

Parameter	Symbol	Rating	Units
Thermal resistance from junction to ambient (airflow = 1m/s)	R _{θJA}	TBD	°C/W
Thermal resistance from junction to pins	R _{θJB}	TBD	°C/W
Thermal resistance from junction to case	R _{θJC}	TBD	°C/W

Note:

1. These parameters are guaranteed by design and tested by a sample basis only.

AC TEST CONDITIONS (OVER THE OPERATING RANGE)

Parameter	Unit (1.65V~2.2V)	Unit (2.4V~3.6V)
Input Pulse Level	0V to V_{DD}	0V to V_{DD}
Input Rise and Fall Time	1.5 ns	1.5 ns
Output Timing Reference Level	$\frac{1}{2} V_{DD}$	$\frac{1}{2} V_{DD}$
R1 (ohm)	13500	319
R2 (ohm)	10800	353
V_{TM} (V)	1.8V	3.3V
Output Load Conditions	Refer to Figure 1 and 2	

AC TEST LOADS

FIGURE 1

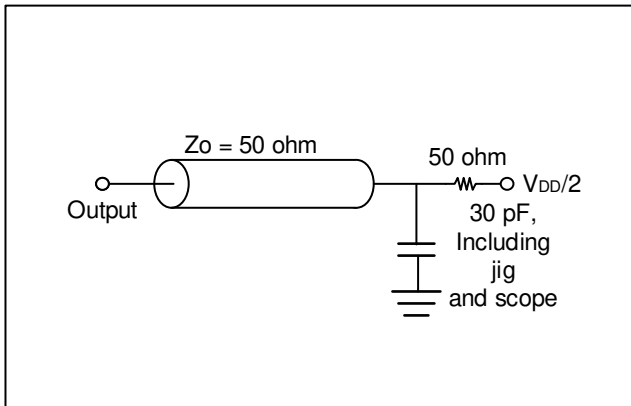
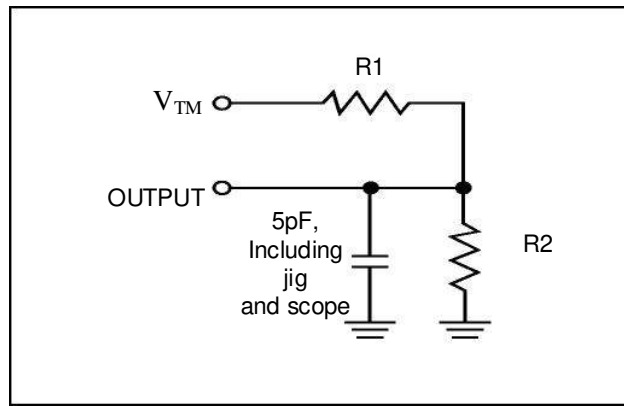

FIGURE 2



DC ELECTRICAL CHARACTERISTICS

DC ELECTRICAL CHARACTERISTICS (OVER THE OPERATING RANGE)

VDD = 1.65V – 2.2V

Symbol	Parameter	Test Conditions	Min.	Max.	Unit
V _{OH}	Output HIGH Voltage	I _{OH} = -0.1 mA	1.4	—	V
V _{OL}	Output LOW Voltage	I _{OL} = 0.1 mA	—	0.2	V
V _{IH} (¹)	Input HIGH Voltage		1.4	V _{DD} + 0.2	V
V _{IL} (¹)	Input LOW Voltage		-0.2	0.4	V
I _{LI}	Input Leakage	GND < V _{IN} < V _{DD}	-1	1	μA
I _{LO}	Output Leakage	GND < V _{IN} < V _{DD} , Output Disabled	-1	1	μA

Notes:

- V_{ILL}(min) = -1.0V AC (pulse width < 10ns). Not 100% tested.
- V_{IHH}(max) = V_{DD} + 1.0V AC (pulse width < 10ns). Not 100% tested.

DC ELECTRICAL CHARACTERISTICS (OVER THE OPERATING RANGE)

VDD = 2.4V – 3.6V

Symbol	Parameter	Test Conditions	Min.	Max.	Unit	
V _{OH}	Output HIGH Voltage	2.4V ~ 2.7V	V _{DD} = Min., I _{OH} = -1.0 mA	2.0	—	V
		2.7V ~ 3.6V	V _{DD} = Min., I _{OH} = -4.0 mA	2.2		
V _{OL}	Output LOW Voltage	2.4V ~ 2.7V	V _{DD} = Min., I _{OL} = 2.0 mA	—	0.4	V
		2.7V ~ 3.6V	V _{DD} = Min., I _{OL} = 8.0 mA	—	0.4	
V _{IH} (¹)	Input HIGH Voltage	2.4V ~ 2.7V		2.0	V _{DD} + 0.3	V
		2.7V ~ 3.6V		2.0		
V _{IL} (¹)	Input LOW Voltage	2.4V ~ 2.7V		-0.3	0.6	V
		2.7V ~ 3.6V		-0.3	0.8	
I _{LI}	Input Leakage	V _{SS} < V _{IN} < V _{DD}	-2	2	μA	
I _{LO}	Output Leakage	V _{SS} < V _{IN} < V _{DD} , Output Disabled	-2	2	μA	

Note:

- V_{IL}(min) = -0.3V DC ; V_{IL}(min) = -2.0V AC (pulse width 2.0ns). Not 100% tested.
V_{IH}(max) = V_{DD} + 0.3V DC ; V_{IH}(max) = V_{DD} + 2.0V AC (pulse width 2.0ns). Not 100% tested..

POWER SUPPLY CHARACTERISTICS-II FOR POWER (OVER THE OPERATING RANGE)

Symbol	Parameter	Test Conditions	Grade	-8 Max.	-10 Max.	-20 Max	Unit
ICC	V _{DD} Dynamic Operating Supply Current	V _{DD} = MAX, I _{OUT} = 0 mA, f = f _{MAX}	Com.	90	85	80	mA
			Ind.	100	95	90	
			Auto.	-	135	-	
ICC1	Operating Supply Current	V _{DD} = MAX, I _{OUT} = 0 mA, f = 0	Com.	80	80	80	mA
			Ind.	90	90	90	
			Auto.	-	110	-	
ISB1	TTL Standby Current (TTL Inputs)	V _{DD} = MAX, V _{IN} = V _{IH} or V _{IL} CS# ≥ V _{IH} , f = 0	Com.	40	40	40	mA
			Ind.	50	50	50	
			Auto.	-	60	-	
ISB2	CMOS Standby Current (CMOS Inputs)	V _{DD} = MAX, CS# ≥ V _{DD} - 0.2V V _{IN} ≥ V _{DD} - 0.2V, or V _{IN} ≤ 0.2V, f = 0	Com.	30	30	30	mA
			Ind.	40	40	40	
			Auto.	-	50	-	
			Typ. ⁽²⁾	10			

Notes:

1. At f = f_{MAX}, address and data inputs are cycling at the maximum frequency, f = 0 means no input line change.
2. Typical values are measured at V_{DD} = 3.0V/1.8V, T_A = 25 °C and not 100% tested.

AC CHARACTERISTICS (OVER OPERATING RANGE)

READ CYCLE AC CHARACTERISTICS

Parameter	Symbol	-8 ⁽¹⁾		-10 ⁽¹⁾		-20 ⁽¹⁾		unit	notes
		Min	Max	Min	Max	Min	Max		
Read Cycle Time	tRC	8	-	10	-	20	-	ns	
Address Access Time	tAA	-	8	-	10	-	20	ns	
Output Hold Time	tOHA	2.5	-	2.5	-	2.5	-	ns	
CS# Access Time	tACE	-	8	-	10	-	20	ns	
OE# Access Time	tDOE	-	5.5	-	6	-	8	ns	
OE# to High-Z Output	tHZOE	0	4	0	5	0	8	ns	2
OE# to Low-Z Output	tLZOE	0	-	0	-	0	-	ns	2
CS# to High-Z Output	tHZCE	0	4	0	5	0	8	ns	2
CS# to Low-Z Output	tLZCE	3	-	3	-	3	-	ns	2
UB#, LB# Access Time	tBA	-	5.5	-	6	-	8	ns	
UB#, LB# to High-Z Output	tHZB	0	4	0	5	0	8	ns	2
UB#, LB# to Low-Z Output	tLZB	0	-	0	-	0	-	ns	2

Notes:

1. Test conditions assume signal transition times of 1.5 ns or less, timing reference levels of $V_{DD}/2$, input pulse levels of 0V to V_{DD} and output loading specified in Figure 1.
2. Tested with the load in Figure 2. Transition is measured ± 500 mV from steady-state voltage. Not 100% tested.

AC WAVEFORMS

READ CYCLE NO. 1^(1,2) (ADDRESS CONTROLLED, CS# = OE# = UB# = LB# = LOW, WE# = HIGH)

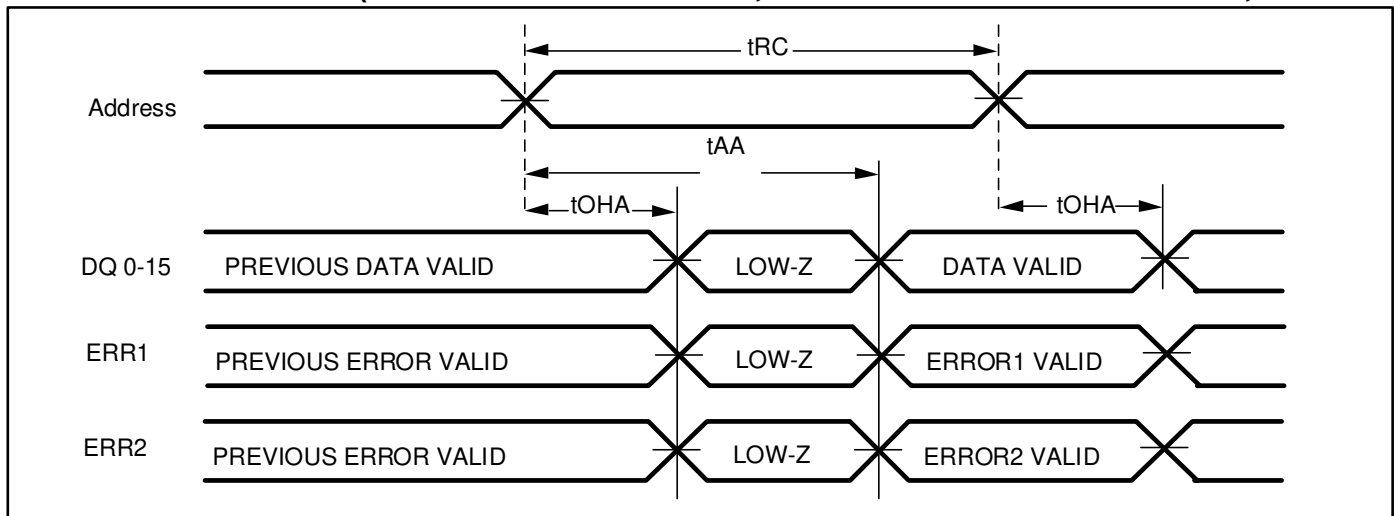

Notes:

1. The device is continuously selected.
2. ERR1, ERR2 signals act like a Read Data Q during Read Operation.

READ CYCLE NO. 2⁽¹⁾ (OE# CONTROLLED, WE# = HIGH)

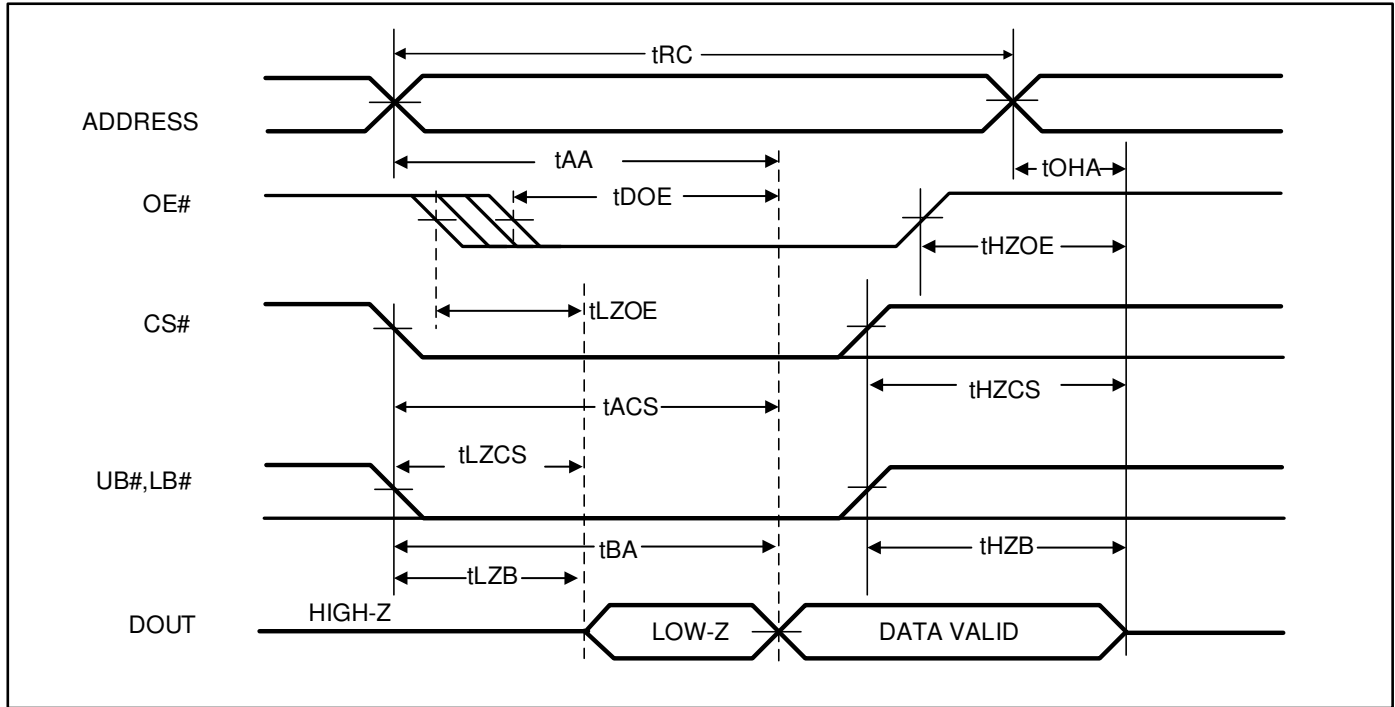

Note:

1. Address is valid prior to or coincident with CS# LOW transition.

WRITE CYCLE AC CHARACTERISTICS

Parameter	Symbol	-8 ⁽¹⁾		-10 ⁽¹⁾		-20 ⁽¹⁾		unit	notes
		Min	Max	Min	Max	Min	Max		
Write Cycle Time	tWC	8	-	10	-	20	-	ns	
CS# to Write End	tSCS	6.5	-	8	-	12	-	ns	
Address Setup Time to Write End	tAW	6.5	-	8	-	12	-	ns	
UB#,LB# to Write End	tPWB	6.5	-	8	-	12	-	ns	
Address Hold from Write End	tHA	0	-	0	-	0	-	ns	
Address Setup Time	tSA	0	-	0	-	0	-	ns	
WE# Pulse Width	tPWE1	6.5	-	8	-	12	-	ns	
WE# Pulse Width (OE# = LOW)	tPWE2	8	-	10	-	17	-	ns	2
Data Setup to Write End	tSD	5	-	6	-	9	-	ns	
Data Hold from Write End	tHD	0	-	0	-	0	-	ns	
WE# LOW to High-Z Output	tHZWE	-	3.5	-	4	-	9	ns	
WE# HIGH to Low-Z Output	tLZWE	2	-	2	-	3	-	ns	

Notes:

- 1 The internal write time is defined by the overlap of CS# = LOW, UB# or LB# = LOW, and WE# = LOW. All conditions must be in valid states to initiate a Write, but any condition can go inactive to terminate the Write. The Data Input Setup and Hold timing are referenced to the rising or falling edge of the signal that terminates the write.
- 2 tPWE > tHZWE + tSD when OE# is LOW.

AC WAVEFORMS

WRITE CYCLE NO. 1 (CS# CONTROLLED, OE# = HIGH OR LOW)

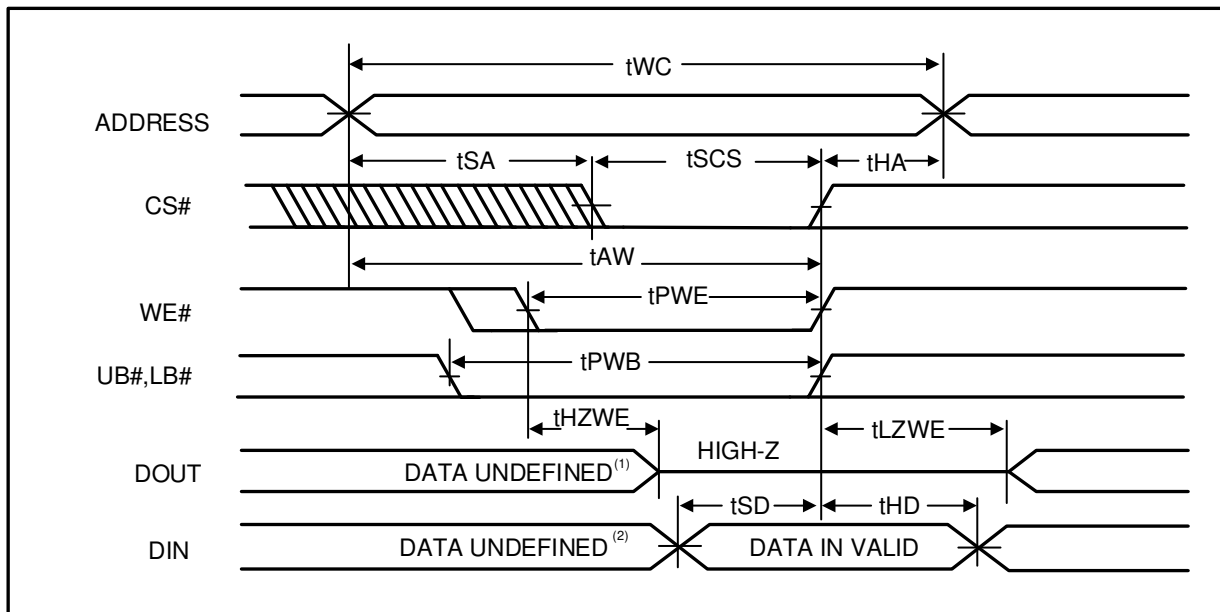

Note:

1. tHZWE is based on the assumption when tSA=0nS after READ operation. Actual DOUT for tHZWE may not appear if OE# goes high before Write Cycle.

WRITE CYCLE NO. 2^(1,2) (WE# CONTROLLED: OE# IS HIGH DURING WRITE CYCLE)

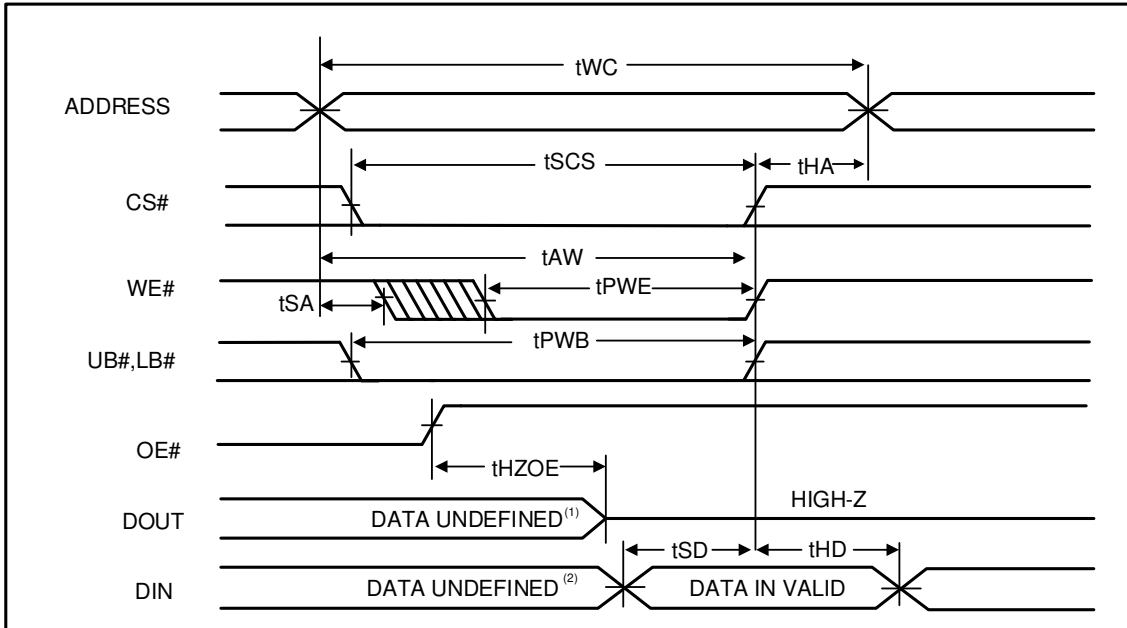

Notes:

1. tHZOE is the time DOUT goes to High-Z after OE# goes high.
2. During this period the I/Os are in output state. Do not apply input signals.

WRITE CYCLE NO. 3⁽¹⁾ (WE# CONTROLLED: OE# IS LOW DURING WRITE CYCLE)

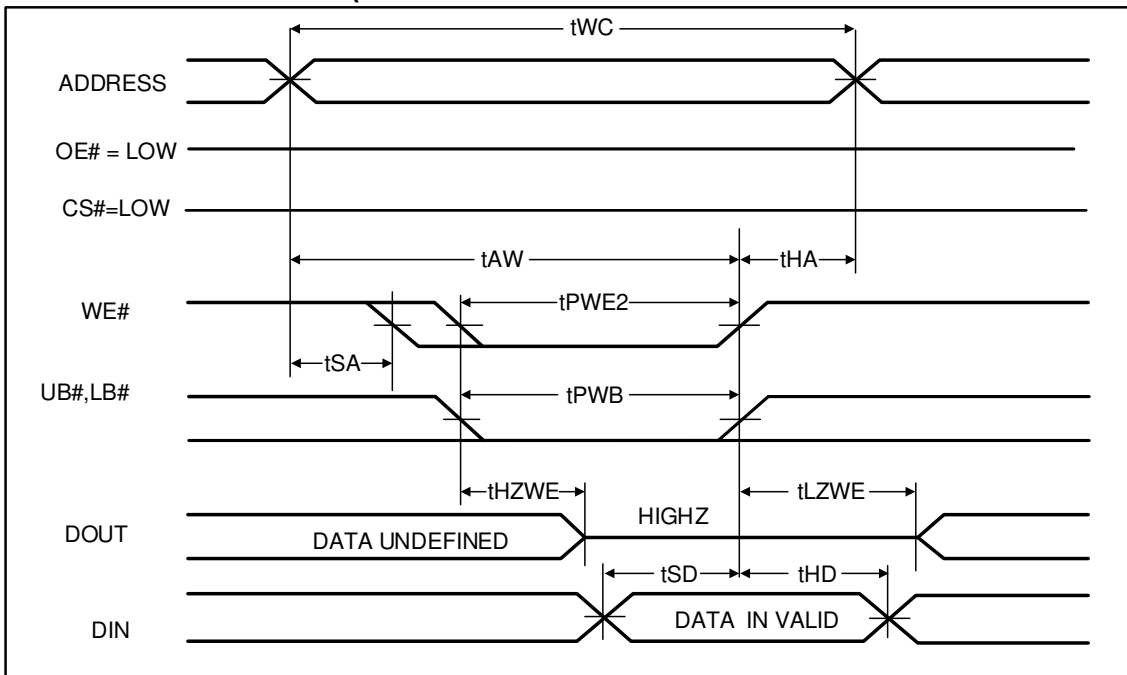

Note:

3. If OE# is low during write cycle, tHZWE must be met in the application. Do not apply input signal during this period. Data output from the previous READ operation will drive IO BUS.

WRITE CYCLE NO. 4^(1, 2, 3) (UB# & LB# Controlled, CS# = OE# = LOW)

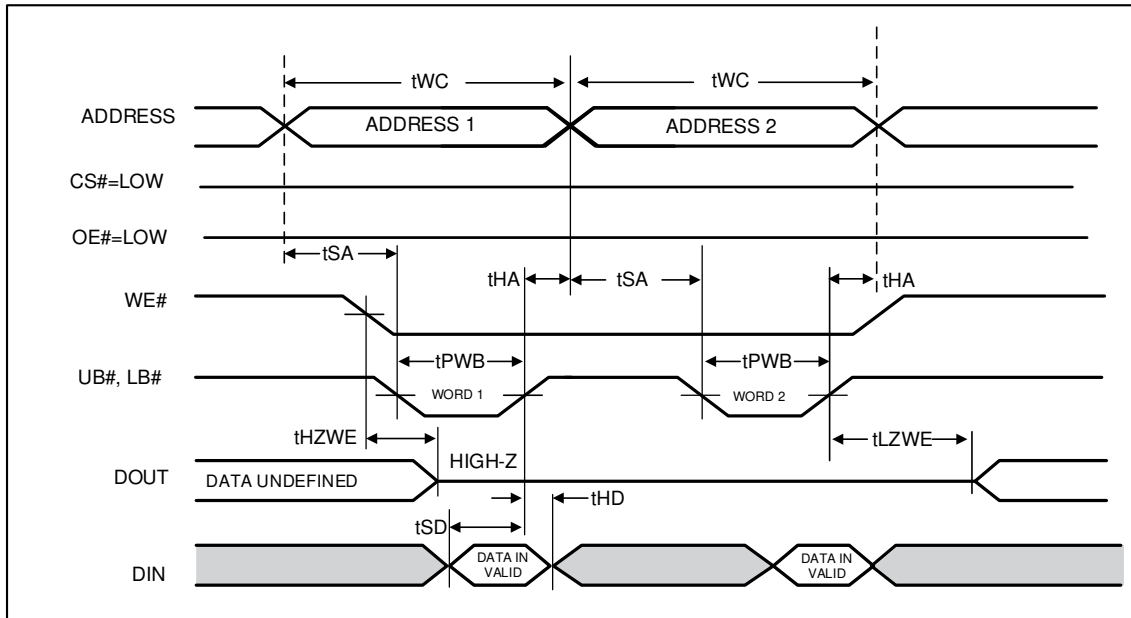

Notes:

- 1 If OE# is low during write cycle, tHZWE must be met in the application. Do not apply input signal during this period. Data output from the previous READ operation will drive IO BUS.
- 2 Due to the restriction of note1, OE# is recommended to be HIGH during write period.
- 3 WE# stays LOW in this example. If WE# toggles, tPWE and tHZWE must be considered.

DATA RETENTION CHARACTERISTICS

Symbol	Parameter	Test Condition	OPTION	Min.	Typ. ⁽²⁾	Max.	Unit
V _{DR}	V _{DD} for Data Retention	See Data Retention Waveform	V _{DD} = 2.4V to 3.6V	2.0		3.6	V
			V _{DD} = 1.65V to 2.2V	1.2		3.6	
I _{DR}	Data Retention Current	V _{DD} = V _{DR} (min), CS# ≥ V _{DD} - 0.2V	Com.	-	10	30	mA
			Ind.	-	-	40	
			Auto	-	-	50	
t _{SDR}	Data Retention Setup Time	See Data Retention Waveform		0	-	-	ns
t _{RDR}	Recovery Time	See Data Retention Waveform		t _{RC}	-	-	ns

Note:

1. If CS# ≥ V_{DD}-0.2V, all other inputs including UB# and LB# must meet this condition.
2. CS#=H means CS1#=HIGH, and CS2=LOW in Dual Chip Select Device
3. Typical values are measured at V_{DD} = V_{DR} (Min), T_A = 25 °C and not 100% tested.

DATA RETENTION WAVEFORM (CS# CONTROLLED)

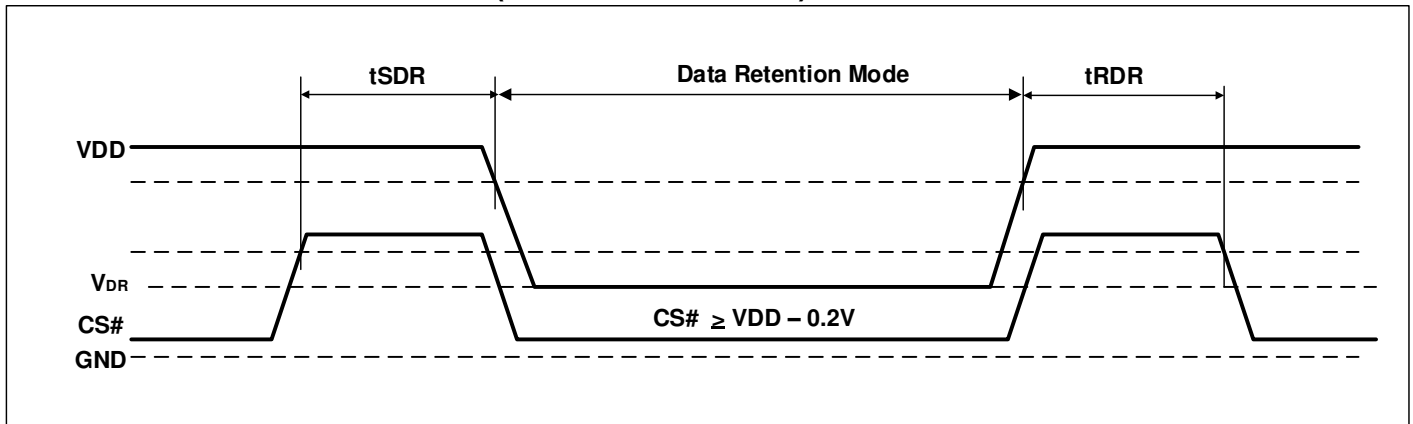

ORDERING INFORMATION

Industrial Range: -40°C to +85°C, Voltage Range: 1.65V to 2.2V

Speed (ns)	Order Part No.	Package
20	IS61WV51216EEALL-20BLI	mini BGA (6mm x 8mm), Lead-free
20	IS61WV51216EEALL-20B2LI	mini BGA (6mm x 8mm), ERR1/2 Pins, Lead-free
20	IS61WV51216EEALL-20TLI	44 TSOP (Type II), Lead-free
20	IS61WV51216EEALL-20T2LI	48 TSOP (Type I), ERR1/2 Pins, Lead-free

Industrial Range: -40°C to +85°C, Voltage Range: 2.4V to 3.6V

Speed (ns)	Order Part No.	Package
8	IS61WV51216EEBLL-8BI	mini BGA (6mm x 8mm)
8	IS61WV51216EEBLL-8BLI	mini BGA (6mm x 8mm), Lead-free
8	IS61WV51216EEBLL-8B2I	mini BGA (6mm x 8mm), ERR1/2 Pins
8	IS61WV51216EEBLL-8B2LI	mini BGA (6mm x 8mm), ERR1/2 Pins, Lead-free
8	IS61WV51216EEBLL-8TLI	44 TSOP (Type II), Lead-free
8	IS61WV51216EEBLL-8T2LI	48 TSOP (Type I), ERR1/2 Pins, Lead-free
8	IS61WV51216EEBLL-8T3LI	54 TSOP (Type II), Lead-free
8	IS61WV51216EEBLL-8T4LI	54 TSOP (Type II), ERR1/2 Pins, Lead-free
10	IS61WV51216EEBLL-10BI	mini BGA (6mm x 8mm)
10	IS61WV51216EEBLL-10BLI	mini BGA (6mm x 8mm), Lead-free
10	IS61WV51216EEBLL-10B2I	mini BGA (6mm x 8mm), ERR1/2 Pins
10	IS61WV51216EEBLL-10B2LI	mini BGA (6mm x 8mm), ERR1/2 Pins, Lead-free
10	IS61WV51216EEBLL-10TLI	44 TSOP (Type II), Lead-free
10	IS61WV51216EEBLL-10T2LI	48 TSOP (Type I), ERR1/2 Pins, Lead-free
10	IS61WV51216EEBLL-10T3LI	54 TSOP (Type II), Lead-free
10	IS61WV51216EEBLL-10T4LI	54 TSOP (Type II), ERR1/2 Pins, Lead-free

Automotive Range (A3): -40°C to +125°C, Voltage Range: 2.4V to 3.6V

Speed (ns)	Order Part No.	Package
10	IS64WV51216EEBLL-10BA3	mini BGA (6mm x 8mm)
10	IS64WV51216EEBLL-10BLA3	mini BGA (6mm x 8mm), Lead-free
10	IS64WV51216EEBLL-10B2A3	mini BGA (6mm x 8mm), ERR1/ERR2 Pins
10	IS64WV51216EEBLL-10B2LA3	mini BGA (6mm x 8mm), ERR1/ERR2 Pins, Lead-free
10	IS64WV51216EEBLL-10CTLA3	44 TSOP (Type II), Copper Leadframe, Lead-free
10	IS64WV51216EEBLL-10CT2LA3	48 TSOP (Type I), Copper Leadframe, ERR1/2 Pins, Lead-free
10	IS64WV51216EEBLL-10CT3LA3	54 TSOP (Type II), Copper Leadframe, Lead-free
10	IS64WV51216EEBLL-10CT4LA3	54 TSOP (Type II), Copper Leadframe, ERR1/2 Pins, Lead-free

PACKAGE INFORMATION

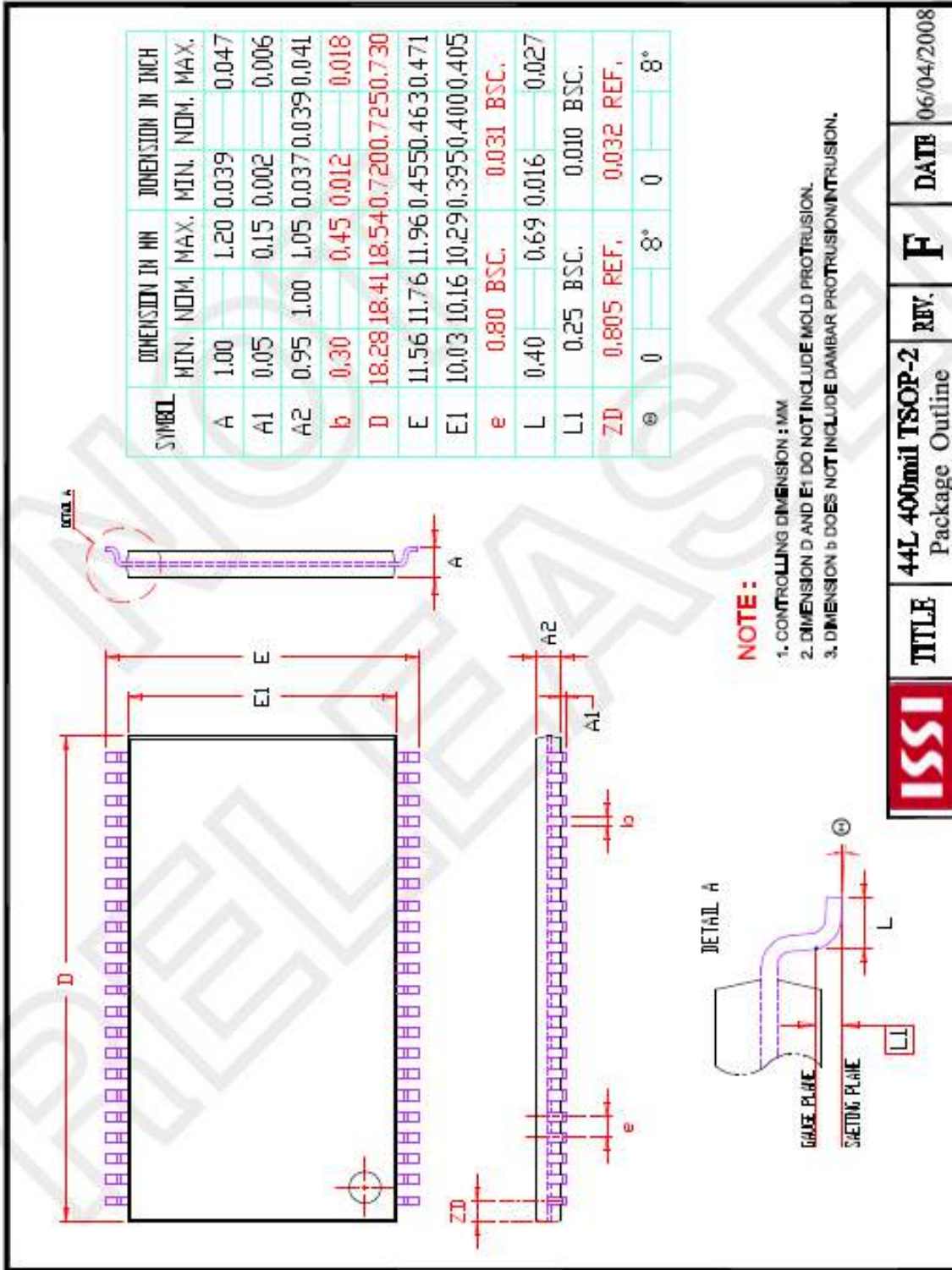

ISSI	TITLE	REV.	DATE
	44L-400mil TSOP-2 Package Outline	F	06/04/2008

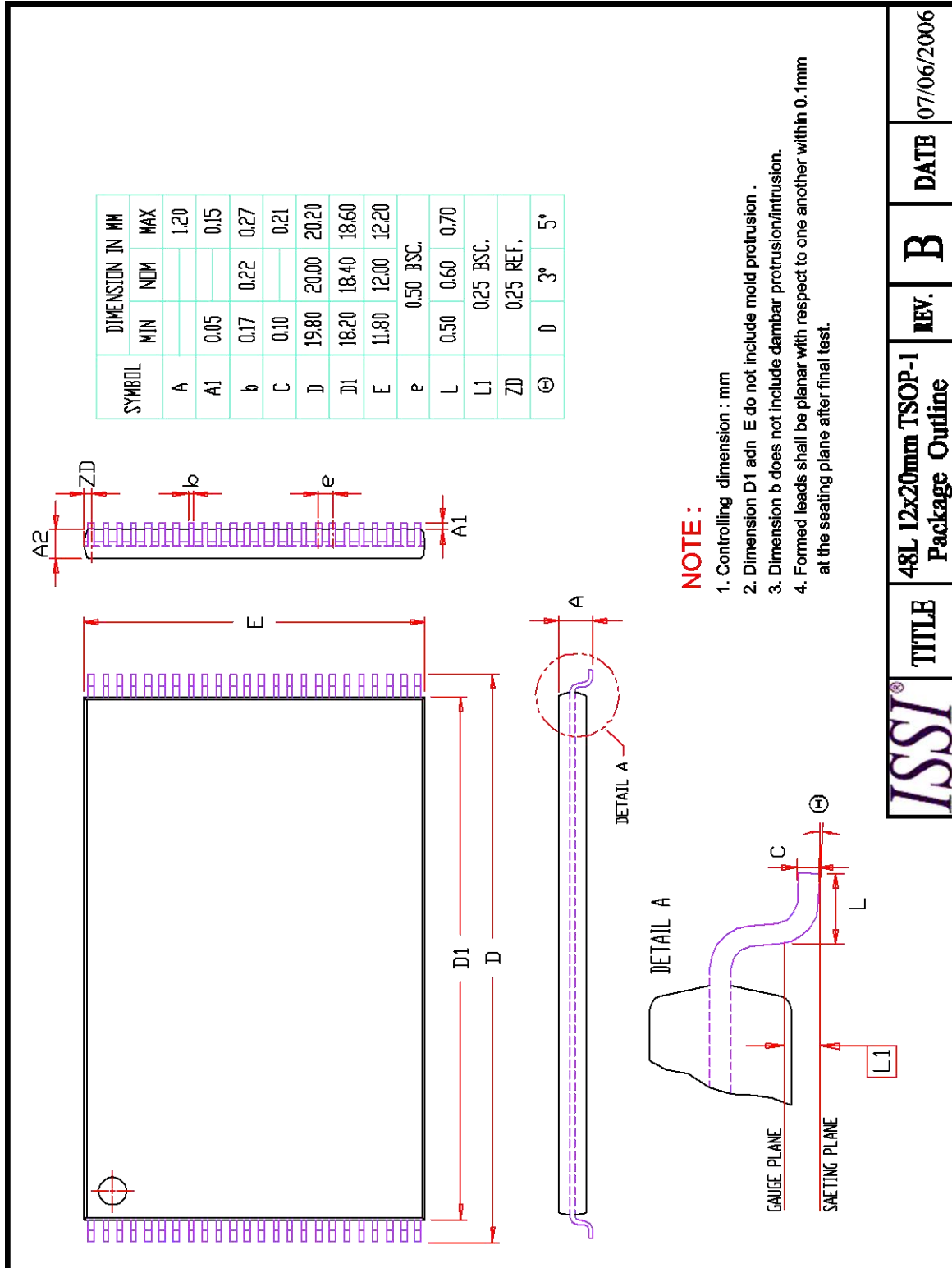

ISSI	48L 12x20mm TSOP-1 Package Outline	REV. B	DATE 07/06/2006
------	------------------------------------	--------	-----------------

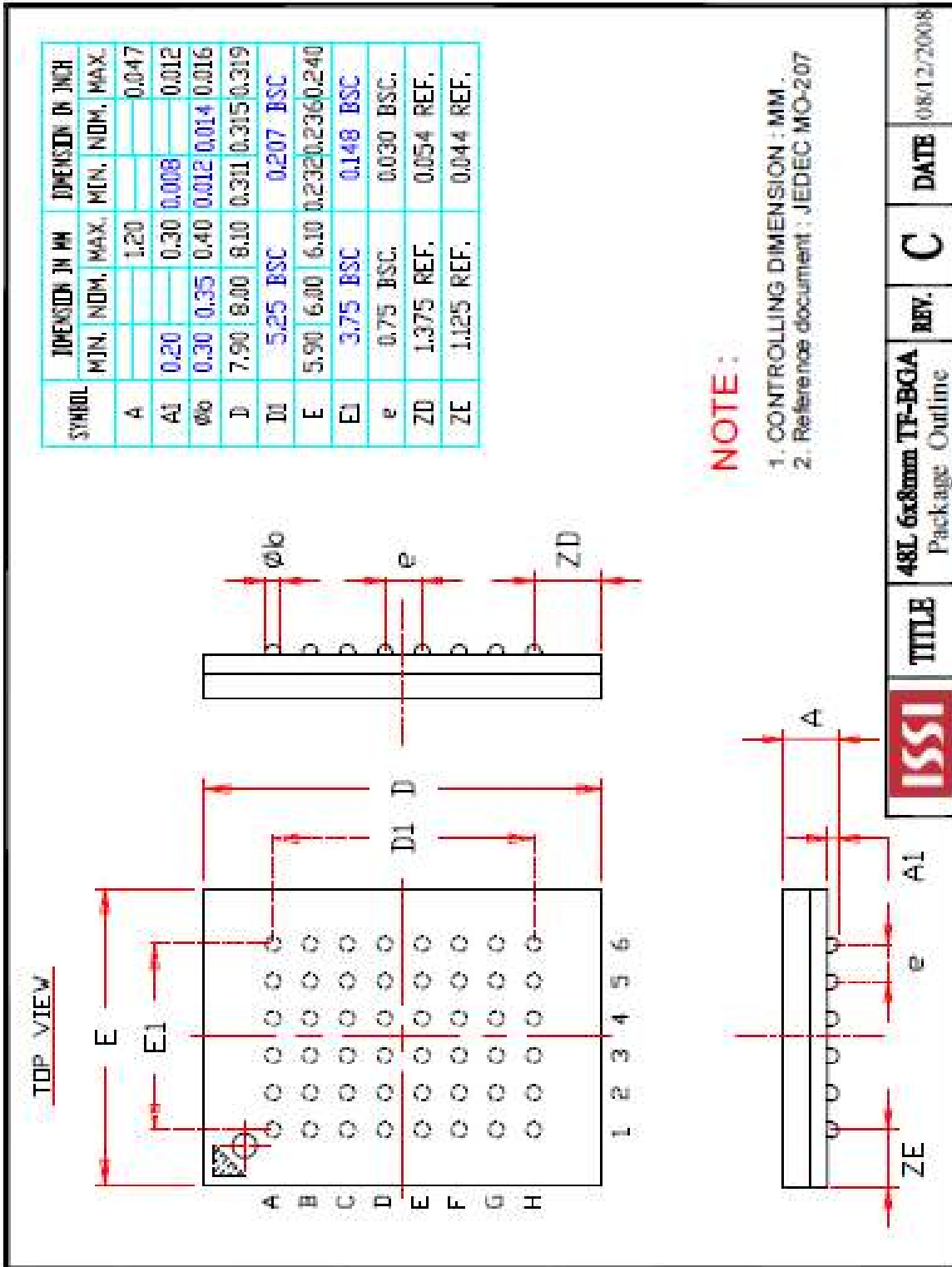

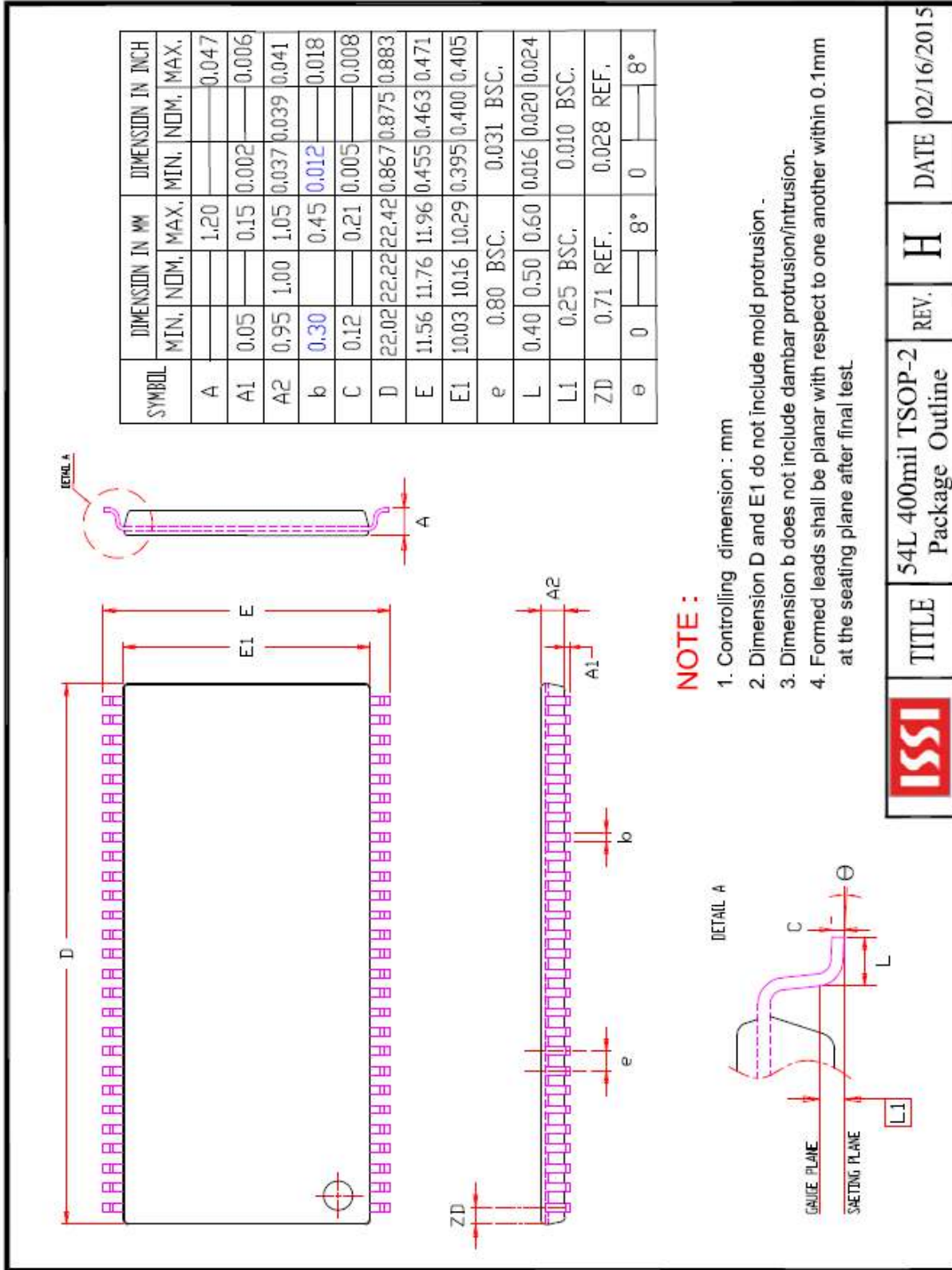

	TITLE	REV.	DATE
	54L 400mil TSOP-2 Package Outline	H	02/16/2015