





APPLICABLE STANDARD					
RATING	OPERATING TEMPERATURE RANGE	-55 °C TO 85 °C ⁽¹⁾	STORAGE TEMPERATURE RANGE	-10 °C TO 60 °C ⁽²⁾	
	VOLTAGE	200 V AC	OPERATING HUMIDITY RANGE	RELATIVE HUMIDITY 85% MAX	
	CURRENT	1 A	STORAGE HUMIDITY RANGE	(NOT DEWED)	
SPECIFICATIONS					
ITEM	TEST METHOD		REQUIREMENTS	QT	AT
CONSTRUCTION					
GENERAL EXAMINATION	VISUALLY AND BY MEASURING INSTRUMENT.		ACCORDING TO DRAWING.	x	x
MARKING	CONFIRMED VISUALLY.			x	x
ELECTRIC CHARACTERISTICS					
CONTACT RESISTANCE	100 mA (DC or 1000 Hz).		15 mΩ MAX.	x	-
INSULATION RESISTANCE	500 V DC.		1000 MΩ MIN.	x	-
VOLTAGE PROOF	650 V AC FOR 1 min.		NO FLASHOVER OR BREAKDOWN.	x	-
MECHANICAL CHARACTERISTICS					
MECHANICAL OPERATION	500 TIMES INSERTIONS AND EXTRACTIONS.		① CONTACT RESISTANCE: 15 mΩ MAX. ② NO DAMAGE, CRACK AND LOOSENESS OF PARTS.	x	-
VIBRATION	FREQUENCY 10 TO 55 Hz, AMPLITUDE : 1.5 mm, AT 2 h FOR 3 DIRECTION.		① NO ELECTRICAL DISCONTINUITY OF 1 μs. ② NO DAMAGE, CRACK AND LOOSENESS OF PARTS.	x	-
SHOCK	490 m/s ² , DURATION OF PULSE 11 ms AT 3 TIMES FOR 3 DIRECTIONS.			x	-
ENVIRONMENTAL CHARACTERISTICS					
DAMP HEAT (STEADY STATE)	EXPOSED AT 40±2 °C, 90 ~ 95 %, 96 h.		① CONTACT RESISTANCE: 15 mΩ MAX. ② INSULATION RESISTANCE: 1000 MΩ MIN.	x	-
RAPID CHANGE OF TEMPERATURE 	TEMPERATURE -55→+15~+35→+125→+15~+35°C TIME 30 → 10~15 → 30 → 10~15 min UNDER 5 CYCLES.		③ NO DAMAGE, CRACK AND LOOSENESS OF PARTS.	x	-
CORROSION SALT MIST	EXPOSED IN 5 % SALT WATER SPRAY FOR 48 h.		① CONTACT RESISTANCE: 15 mΩ MAX. ② NO HEAVY CORROSION.	x	-
HYDROGEN SULPHIDE	EXPOSED IN 3 PPM FOR 120 h.			x	-
	COUNT	DESCRIPTION OF REVISIONS	DESIGNED	CHECKED	DATE
	1	DIS-F-00010330	YS. NARA	HT. YAMAGUCHI	20210720
REMARK ⁽¹⁾ TEMPERATURE RISE INCLUDED WHEN ENERGIZED. ⁽²⁾ THIS STORAGE INDICATES A LONG-TERM STORAGE STATE FOR THE UNUSED PRODUCT BEFORE THE BOARD MOUNTED.			APPROVED	HT. YAMAGUCHI	20181211
			CHECKED	HT. YAMAGUCHI	20181211
			DESIGNED	MT. ITANO	20181211
Unless otherwise specified, refer to MIL-STD-202.			DRAWN	TS. HORI	20181207
Note QT:Qualification Test AT:Assurance Test X:Applicable Test			DRAWING NO.		ELC-386212-00-00
	SPECIFICATION SHEET		PART NO.	HIF3B*-*P-2. 54W (63)	
	HIROSE ELECTRIC CO., LTD.		CODE NO.		1/1

2023/03/30 23:43:59(JST) Christopher J Tubbs
 RoHS2(10 substances conformity)
 DRAWING FOR REFERENCE: This is subject to change without notice
 In cases where the application will demand a high level of reliability, such as automotive, please contact a company representative for further information.



Notes 1 The upper dimension shows when the lock open out.
 2 The dimensions in parentheses are for reference.
 3 UL(File No. E52653)
 C-UL(File No. E52653) authorization article.

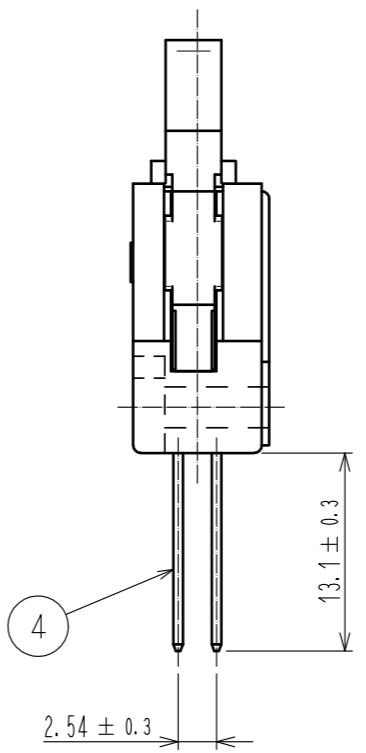
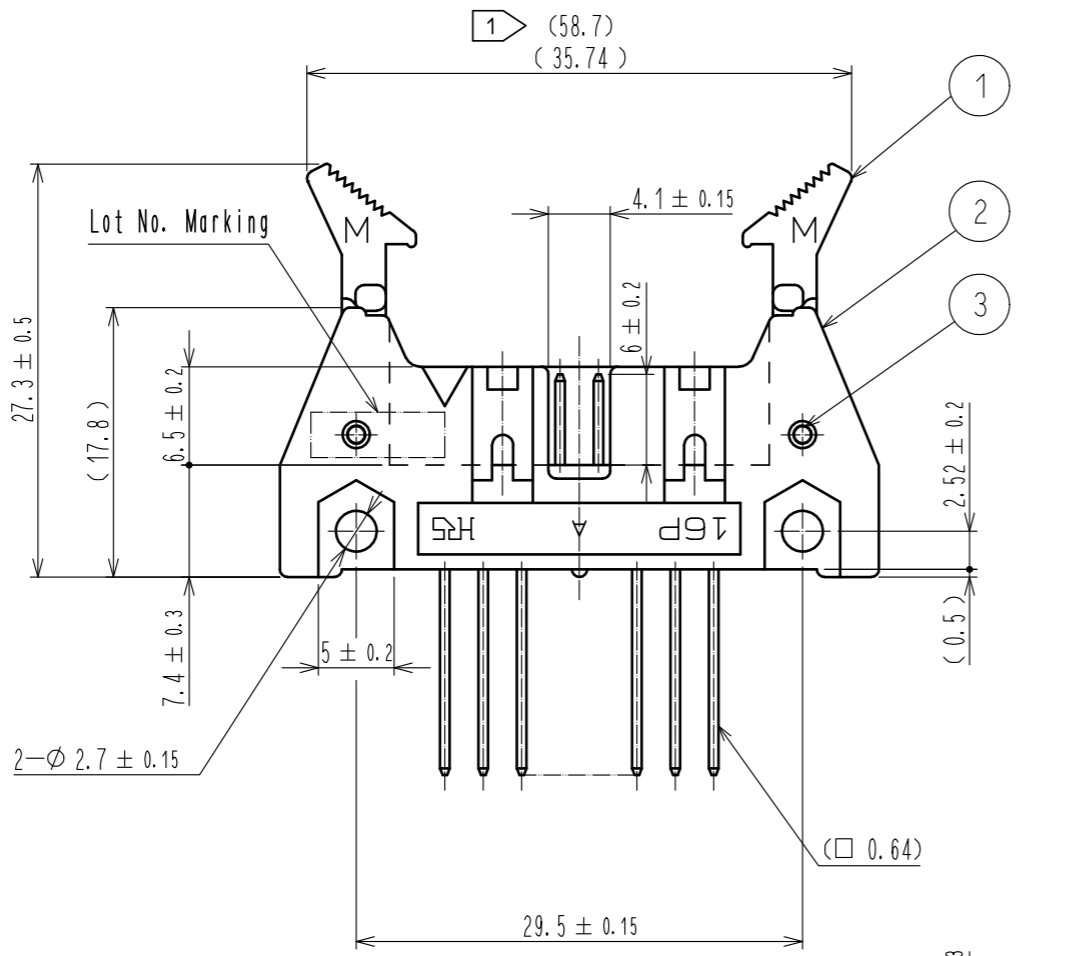
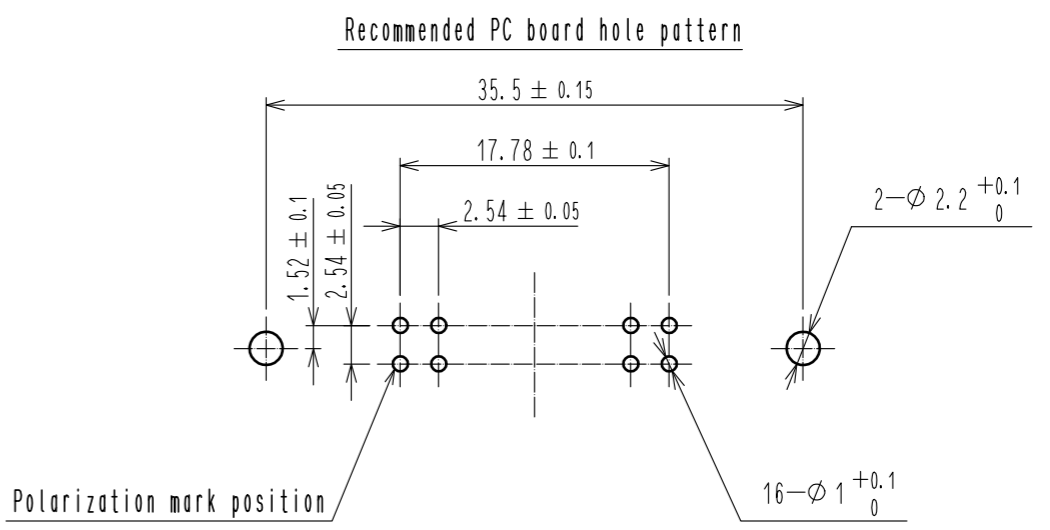
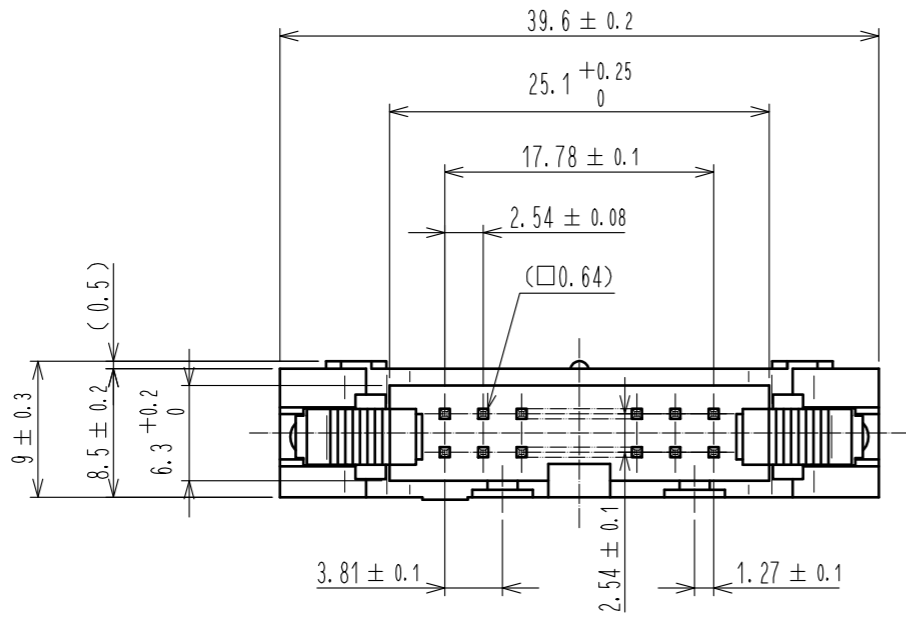
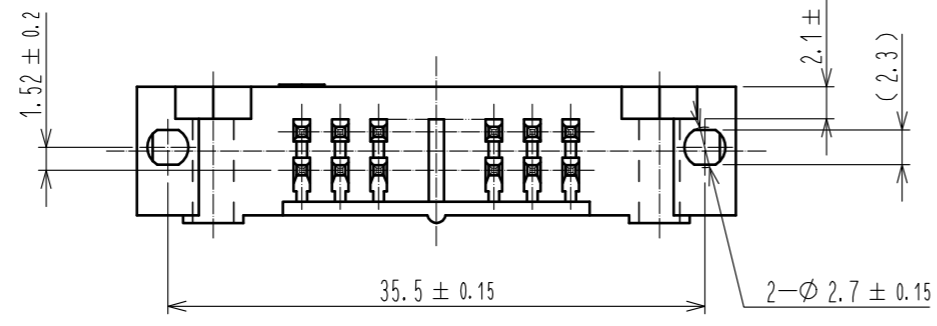

3	STAINLESS						
2	PBT	BLACK	UL94V-0	4	BRASS	Surface: Gold 0.2μm min.	
1	PBT	BLACK	UL94V-0			Under plating: Nickel 3μm min.	
NO.	MATERIAL	FINISH	REMARKS	NO.	MATERIAL	FINISH	REMARKS
UNITS	mm	SCALE	2 : 1	COUNT	1	DESCRIPTION OF REVISIONS	DESIGNED
						DIS-F-00005891	AK. IWAHORI
							CHECKED
							HT. YAMAGUCHI
							DATE
							20200227
APPROVED : HT. YAMAGUCHI		20181211		DRAWING NO.		EDC-018813-63-00	
CHECKED : HT. YAMAGUCHI		20181211		PART NO.		HIF3BA-16P-2.54W(C63)	
DESIGNED : MT. ITANO		20181211		CODE NO.		CL610-0494-9-63	
DRAWN : MK. OKI		20181207					