



Self-seating Connector Accessories Circular Backshells



SUNBANK is a brand name of Esterline Connection Technologies

For over 50 years Sunbank has been supporting the interconnect market by designing products that define the standards for highly reliable products required for harsh environments. Sunbank's self-seating products provide superior backshell interface solution with the connector compared to conventional self-locking products. We proudly support Aerospace, Defense, Marine, and Industrial power and signal interconnect markets, worldwide since 1958.

Contents

Overview

Applications.....	7
Features and Benefits.....	8
Range Overview.....	9

General information

Sunbank Accessory Interface Data-Standards.....	17
Military Standard Connector Matrix.....	21
Manufacturer Connector Matrix.....	32
Sunbank Standard Materials And Dimensional Tolerances....	38
Sunbank Standard Plating Finishes, Table II	39
Sunbank Connector Accessory Interface Standards, Table I	40
Maximum Cable Diameters.....	41
Sunbank Accessory Modification Codes	42
Sunbank Standard Installation.....	43
Sunbank Accessory To Shrink Boot.....	44
Basic Assembly Instructions	45

Products and hardware

03 Band Adapter Product Index	50
06 Shrink Boot Adapter Products	74
09 Strain Relief Adapter Products	86
12 Adapter Extender Products	96
15 Non-Environmental Adapter Products	100
18 Environmental Adapter Products.....	104
21 EMI/RFI Adapter Products	110
24 EMI/RFI Environmental Adapter Products	128
33 EMI/RFI S Spring Adapter Products.....	138
36 Shorting Can Adapter Products	148
39 Pipe Thread Adapter Products	144
51 Lamp Base Adapter Products.....	148
57 Commercial Conduit Adapter Products	152
90 Accessory Hardware Products	162
99 Assembly Tool Products.....	169

OVERVIEW

Self-seating Connector Accessories

Overview

■ Applications	7
■ Features & Benefits	8
■ Range Overview	9



Typical applications



© Dell / Fotolia

Civil Aviation



© Jathis / Shutterstock

Military Aircraft



© Mechnik / Shutterstock

Space



© JPS / Fotolia

Industry



© Glenn Fawcett

Ground Transportation



U.S. Navy photo

Military Marine

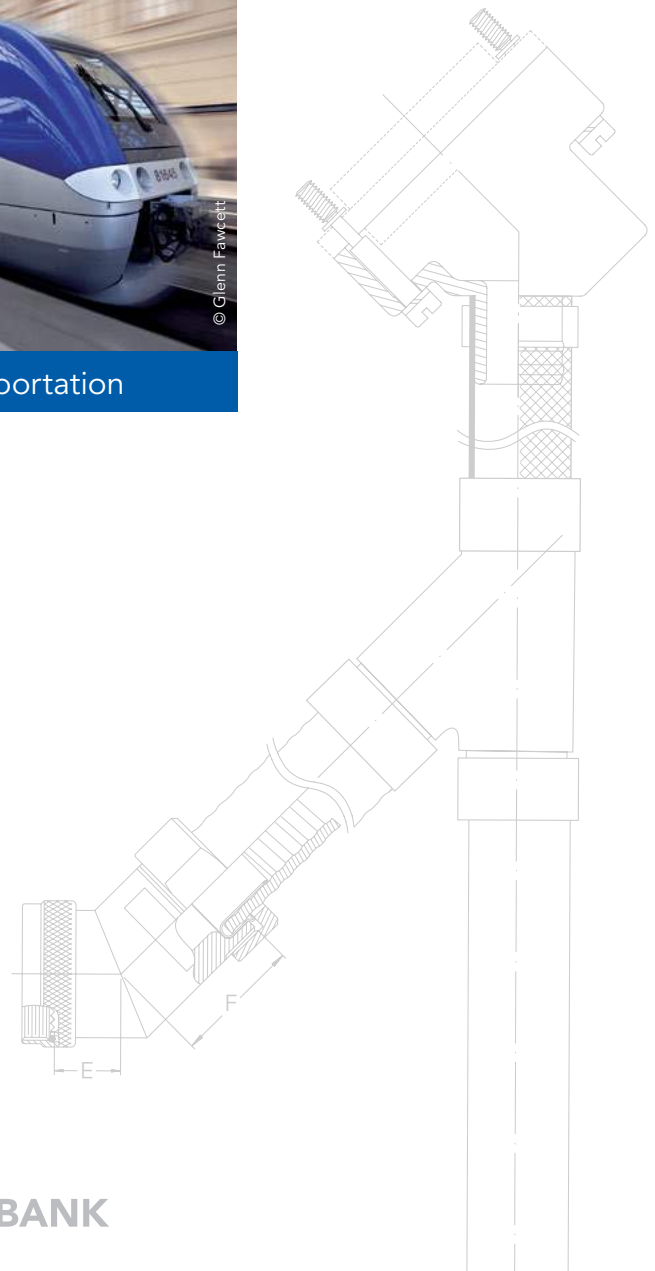

Features & Benefits

SELF CONTAINED

Product Envelope Environmental

The Self-seating mechanism provides a robust and simple connector interface when compared to other conventional, multi-step, and labor intensive self-locking products; Sunbank provides a lower mass product in a smaller envelope.

ALIGNMENT

Connector Mating/Alignment

Self-seating Products ensure that there is NO connector and accessory misalignment. Positive and accurate alignment features ensure minimal side loading condition as present in conventional self-locking products.

MECHANICAL /ELECTRICAL

Mechanical Decoupling

Self-seating products provide superior mechanical performance when compared to other self-locking products. Also utilizes minimal torque values, while achieving optimal electrical and mechanical bonding between the accessory and connector shells.

ENVIRON- MENTAL

Global Plating Compliance

The Self-seating products are available in a wide range of surface finishes to protect against harsh environments while maintaining mechanical, electrical, and green integrity.

COST SAVINGS

Ease of Installation

Imagine the material and labor cost savings that can be realized by not having to utilize locking compound, adhesive and lockwire to prevent failure. The self-seating product is a highly reliable and worry free product; basically a 'Set and Forget" system.

Self-seating performance

De-coupling, electrical resistance

Shell size tested	Torque (inch lbs)	Accessory material	Resistance in mohms @ * degree								
			0	45	90	135	180	225	270	315	360
14	19	Stainless Steel	0.29	0.35	0.43	0.45	0.47	0.51	0.60	0.64	0.78
18	29	Aluminum	0.14	0.41	0.51	0.53	0.53	0.63	0.61	0.71	0.74
22	42	Aluminum	0.14	0.18	0.20	0.22	0.24	0.25	0.28	0.31	0.37

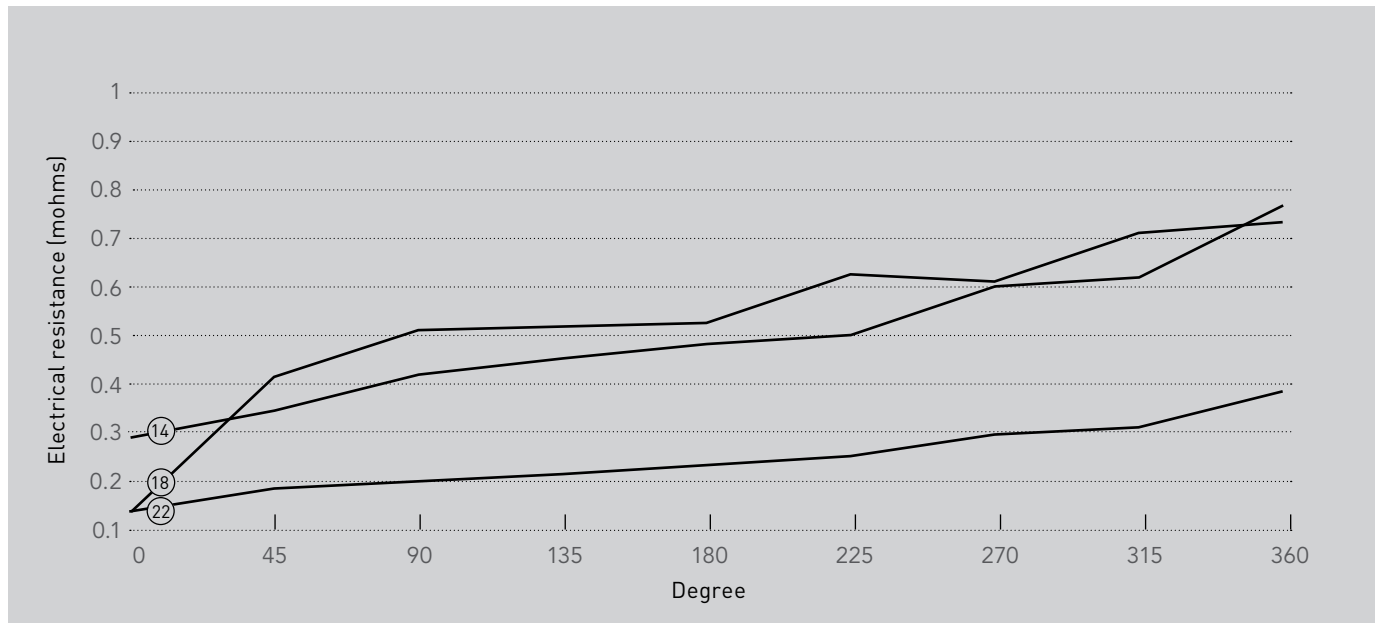

Notes

1. Electrical resistance values are given for information only and are not requirements. Actual values will depend on service conditions, accessory size and configuration.

Self-seating Product Selection Guide

The following self-seating product descriptions are provided to assist in selecting the appropriate circular connector accessory. Please see individual series pages for additional design variants.

03 Series

Band adapter products

Band adapter products provide an economical (full 360°) approach to terminating overall or individual cable shielding, especially where future maintenance or repairability are required.

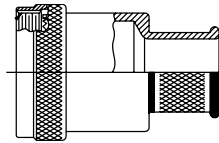

06 Series

Shrink boot adapter products

Shrink boot shape products are configured to accommodate heat-activated or cold shrink boot shapes. These adapters can be provided with preterminated braided shielding.

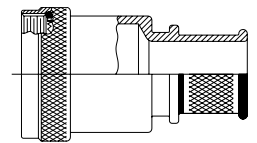

09 Series

Strain relief adapter products

Strain relief adapter products provide mechanical cable bundle clamping for light, medium and heavy duty applications. 90° designs are also offered for most available connectors.

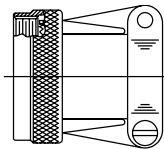

12 Series

Adapter extender products

Adapter extender products allow for a greater amount of working area, behind the connector, while allowing the use of the provided strain relief.

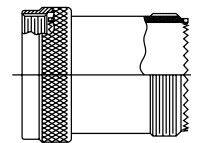

15 Series

Non-environmental adapter products

Non-environmental adapter products are designed with provisions for strain relief straight, 45° and 90° options.

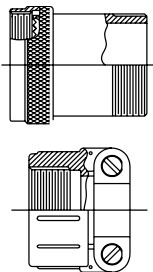

18 Series

Environmental adapter products

Environmental adapter products are designed for cable sealing or moisture resistance, offered with a selection of available strain relief clamps and provisions for straight, 45° and 90° options. Note: cable sealing, fluid immersion, moisture resistant, splash-proof and dust resistance.

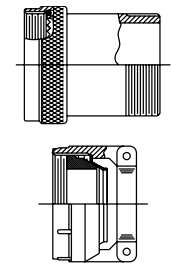

21 Series

EMI/RFI adapter products

EMI/RFI adapter products provide individual and/or overall shield termination for optimal continuity. Products are offered with choice of strain relief and provisions for straight, 45°, and 90° options.

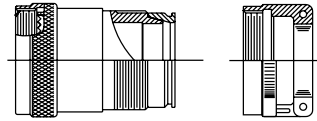

24 Series

EMI/RFI environmental products

EMI/RFI environmental products offer the combination of options available in Product series 18 and 21. The end result is a shield-terminating, environment resisting design with strain relief and orientation options.

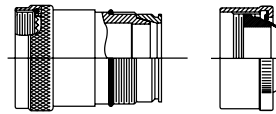

33 Series

EMI/RFI S spring adapter products

EMI/RFI spring adapter products offer termination and grounding for cables utilizing metal foil and/or shield braid for overall cable shielding. The cable circumference is completely grounded to the adapter via the peripheral spring component provided.

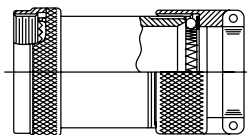

36 Series

Shorting can adapter products

Shorting can adapter products provide an enclosed protective area behind the connector for the assembly of test connectors and shorting plug assemblies.

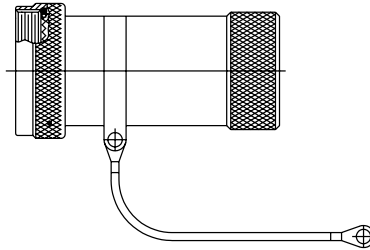

39 Series

Pipe thread adapter products

Pipe thread adapter products are designed to fit most National Pipe Thread (NPT) standardized parts (i.e. hose fittings, conduit).

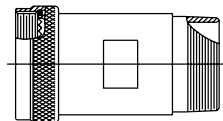

51 Series

Lamp base adapter products

Lamp base adapter products are designed to provide cable bundle shield termination via 360° compression form and opposing threaded compression nut. To complete the assembly, the use of a heat-activated or cold shrink boot is suggested for jacketed cable.

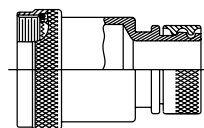

57 Series

Commercial conduit product adapters

Commercial conduit product adapters allow for field installable termination of Sealtite® (Liquidtite®) conduit, typically associated with most industrial applications.

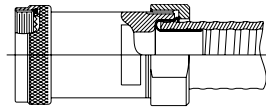

90 Series

Accessory hardware products

Accessory hardware products allow for the completed assembly or repair of various interconnect system situations.

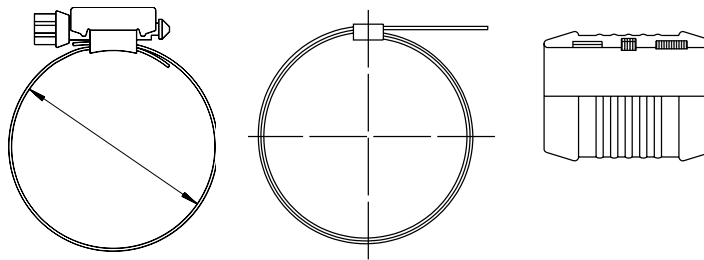

99 Series

Assembly tool products

Assembly tool products are designed to support the need of today's interconnect product lines. All Sunbank tools provide cost effective, consistent, high reliability performance needed for today's military and aerospace environment.

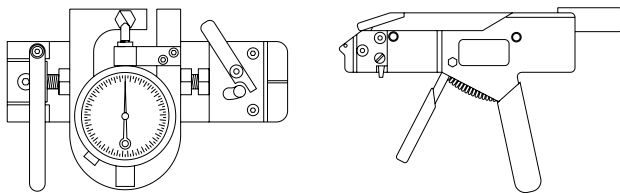

GENERAL INFORMATION

Self-Seating Connector Accessories

General Information

■ Sunbank Accessory Interface Data-Standards.....	17
■ Military Standard Connector Matrix	21
■ Manufacturer Connector Matrix	32
■ Sunbank Standard Materials And Dimensional Tolerances	38
■ Sunbank Standard Plating Finishes, Table II	39
■ Sunbank Connector Accessory Interface Standards, Table I.....	40
■ Maximum Cable Diameters	41
■ Sunbank Accessory Modification Codes	42
■ Sunbank Standard Installation	43
■ Sunbank Accessory To Shrink Boot.....	44
■ Basic Assembly Instructions.....	45

Standards

Series code designator	Connector specification	Connector series	US	International
A1	MIL-C-5015	MS3400	X	
	MIL-C-26482	Series II	X	
	MIL-C-81703	Series III	X	
	MIL-C-83723	Series 1 and III	X	
	NAS1599		X	
	40M39569		X	
	DEF 5326-3			X
	ESC 10 & 11			X
	LN 29504			X
	PAN 6432-1			X
	PAN 6432-2			X
	PATT 602			X
	NFC 93422	HE302		X
	EN 3646			X
	EN 2997			X

Accessory Interface Data

Standards

Series code designator	Connector specification	Connector series	US	International
F3-non environmental (see below)	MIL-C-38999	Series I and II	X	
	40M38277 (NASA)		X	
	PAN 6433-1			X
	PATT 614			X
	PATT 616			X
	NFC 93422	HE 308		X
	NFC93422	HE 309		X
U1	MIL-C-28840		X	
F4-non environmental (see below)	MIL-C-38999	Series III and IV	X	
	EN 3645			X
G1	MIL-C-81511	Series I, II, III and IV	X	
	VG 95329			X
PI	MIL-C-83723	Series II	X	
X1 X2 (see below)	VG96912			X
	LN29729			X
	PAN 6433-2			X
	PATT 615			X
	NFC 93422	HE306		X
	EN 3372			X
A4	PATT 105			X
	PATT 603			X
	PATT 608			X
L1	BACC63	BP,BR,BT,BV	X	
	(Boeing)	CB and CC	X	
A3	MIL-C-5015	Endbell	X	

Notes

- F3, F4 and X1 are standard codes when environmental requirements are not required. Use the following codes when environmental product is required.
 Use code F1 if environmental seal is required. MIL-C-38999 Series I only.
 Use code F2 for moisture proof only. (environmental seal not available) MIL-C-38999 Series I and II only.
 Use code F5 if environmental seal is required. MIL-C-38999 Series III or IV only.
 Use code X2 if environmental seal is required.

Standards

Series code designator	Connector specification	Connector series	US	International
J1	Microdot, MARC	43,53, & 63	X	
K1	Deutsch DM		X	
	MS3132		X	
	MS3134		X	
	MS3137		X	
	MS3138		X	
K2	Deutsch DSM	120, 32000	X	
	Deutsch RSM	UR20, 2300	X	
	Deutsch RMK		X	
	Deutsch SMK		X	
K3	Deutsch DA	19000	X	
	Deutsch DS	17000	X	
	Deutsch DD	12000	X	
	Deutsch MDR	13000	X	
	Deutsch MDS	750, M17000	X	
	MS3140		X	
	MS3144		X	
	MS3147		X	
MS3148		X		
K4	Deutsch RTK	UR40, 74000	X	
	Deutsch STK	340, 4200	X	
K5	Deutsch DTK		X	

Standards

Series code designator	Connector specification	Connector series	US	International
N1	MIL-C-26500 l	SST Shell	X	
	MIL-C-38300		X	
	MS24264	Class 3	X	
	MS24265	Class 3	X	
	MS24266	Class 3	X	
	MS27613	Class 3	X	
	MS.27615	Class 3	X	
T1	MIL-C-5015	Rev E	X	
W1	Burndy	G Series	X	
	(Framatone US)		X	
	Trim Tiro	G0, G1, G6	X	
		G8 and G9	X	

Military Standard Connector Matrix

Connector matrix

Part number	Sunbank connector designator	Specification	Series	Description
MS3100	A2	MIL-C-5015	MS3100	Receptacle, wall mount (solder)
MS3101	A2	MIL-C-5015	MS3100	Receptacle
MS3012	**	MIL-C-5015	MS3100	Receptacle, box mount (solder)
MS3103	**	MIL-C-5015	MS3100	Receptacle, potting (solder)
MS3105	**	MIL-C-5015	MS3100	Dummy receptacle
MS3106	A2	MIL-C-5015	MS3100	Plug, straight (solder)
MS3107	A3	MIL-C-5015	MS3100	Plug, quick disconnect (solder)
MS3108	A3	MIL-C-5015	MS3100	Plug 90 degree (solder)
MS3110	E1	MIL-C-26482	1	Receptacle, wall mount
MS3111	E1	MIL-C-26482	1	Plug, cable connecting
MS3112	**	MIL-C-26482	1	Receptacle, box mount
MS3113	**	MIL-C-26482	1	Receptacle, solder mount
MS3114	E1	MIL-C-26482	1	Receptacle jam nut
MS3115	**	MIL-C-26482	1-2	Dummy receptacle
MS3116	E1	MIL-C-26482	1	Plug, straight
MS3119	**	MIL-C-26482	1	Receptacle, thru-bulkhead
MS3120	E1	MIL-C-26482	1	Receptacle, wall mount (crimp)
MS3121	E1	MIL-C-26482	1	Plug, straight (crimp)
MS3122	**	MIL-C-26482	1	Receptacle, box mount (crimp)
MS3124	E1	MIL-C-26482	1	Receptacle, rear mount, jam nut (crimp)
MS3126	E1	MIL-C-26482	1	Plug, straight (crimp)
MS3127	**	MIL-C-26482	1	Receptacle, box mount (crimp)
MS3128	E1	MIL-C-26482	1	Receptacle, wall mount (crimp)
MS3130	*	MIL-C-81703	1	Receptacle, push pull, wide flange
MS3132	**	MIL-C-81703	1	Receptacle, push pull, box mount
MS3134	K1	MIL-C-81703	1	Receptacle, push pull, jam nut
MS3135	**	MIL-C-81703	1	Dummy receptacle
MS3137	K1	MIL-C-81703	1	Plug, straight, push pull

* Consult factory for assistance

** Connector does not have rear accessory accommodations.

Military Standard Connector Matrix

Connector matrix

Part number	Sunbank connector designator	Specification	Series	Description
MS3138	K1	MIL-C-81703	1	Plug, lanyard, push pull
MS3139	**	MIL-C-81703	1	Receptacle, thru-bulkhead
MS3140	K3	MIL-C-81703	2	Receptacle, push
MS3142	**	MIL-C-5015	MS3100	Receptacle, hermetic, box mount
MS3143	**	MIL-C-5015	MS3100	Receptacle, hermetic, solder mount
MS3144	K3	MIL-C-81703	2	Receptacle, jam nut
MS3145	**	MIL-C-81703	3	Receptacle, box mount, hermetic seal
MS3146	**	MIL-C-81703	3	Receptacle, push pull, hermetic, solder mount
MS3147	K3	MIL-C-81703	2	Plug, push pull (crimp)
MS3148	K3	MIL-C-81703	2	Plug, push pull, lanyard (crimp)
MS3149	**	MIL-C-81703	3	Receptacle, push pull, hermetic
MS3400	A1	MIL-C-5015	MS3400	Receptacle, wall mount
MS3401	A1	MIL-C-5015	MS3400	Receptacle, cable connecting
MS3402	**	MIL-C-5015	MS3400	Receptacle, box mount
MS3404	A1	MIL-C-5015	MS3400	Receptacle, jam nut
MS3406	A1	MIL-C-5015	MS3400	Plug
MS3408	A1	MIL-C-5015	MS3400	Plug, 90 degree
MS3409	A1	MIL-C-5015	MS3400	Plug, 45 degree
MS3412	A1	MIL-C-5015	MS3400	Receptacle, wall mount
MS3424	A1	MIL-C-81703	3	Receptacle, push pull, wall mount
MS3440	**	MIL-C-26482	2	Receptacle, narrow flange mount (was M83723/9/10)
MS3442	**	MIL-C-26482	2	Receptacle, wide flange mount
MS3443	**	MIL-C-26482	2	Receptacle, solder flange mount
MS3445	*	MIL-C-81703	2	Plug, push pull, rack & panel mount
MS3446	A1	MIL-C-81703	3	Plug, rack & panel
MS3449	**	MIL-C-26482	2	Receptacle, single hole mount
MS3450	A1	MIL-C-5015	MS3450	Receptacle, wall mount (was M83723/19/20)
MS3451	A1	MIL-C-5015	MS3450	Receptacle, cable connecting (was M83723/17/18)

* Consult factory for assistance

** Connector does not have rear accessory accommodations.

Military Standard Connector Matrix

Connector matrix

Part number	Sunbank connector designator	Specification	Series	Description
MS3452	**	MIL-C-5015	MS3450	Receptacle, box mount (was M83723/12/22)
MS3454	A1	MIL-C-5015	MS3450	Receptacle, jam nut
MS3456	A1	MIL-C-5015	MS3450	Plug, straight (was M83723/23/24)
MS3459	A1	MIL-C-5015	MS3450	Plug, straight, self-locking (was M83723/52/53)
MS3463	**	MIL-C-81703	3	Receptacle, push pull
MS3464	A1	MIL-C-81703	3	Receptacle, push pull, jam nut
MS3466	**	MIL-C-81703	3	Receptacle, push pull, hermetic
MS3467	A1	MIL-C-81703	3	Plug, push pull
MS3468	A1	MIL-C-81703	3	Plug, push pull, lanyard
MS3469	**	MIL-C-81703	3	Receptacle, push pull, hermetic, jam nut
MS3470	A1	MIL-C-26482	2	Receptacle, narrow flange mount (was M83723/1/2)
MS3471	A1	MIL-C-26482	2	Receptacle, cable connecting (was M83723/7/8)
MS3472	A1	MIL-C-26482	2	Receptacle, wide flange mount (was M83723/3/4)
MS3473	**	MIL-C-26482	2	Receptacle, solder mount hermetic
MS3474	A1	MIL-C-26482	2	Receptacle, rear mount, jam nut (was M83723/5/6)
MS3475	A1	MIL-C-26482	2	Plug, RFI shielded (was M83723/42/43)
MS3476	A1	MIL-C-26482	2	Plug, straight (was M83723/13/14)
MS3477	**	MIL-C-26482	2	Receptacle hermetic, box mount
MS3479	**	MIL-C-26482	2	Receptacle, hermetic, rear mount, jam nut
MS17343	H1	MIL-C-22992	R	Receptacle, wall mount
MS17344	H1	MIL-C-22992	R	Plug, straight
MS17345	H1	MIL-C-22992	R	Plug, cable connecting
MS17346	**	MIL-C-22992	R	Receptacle, box mount
MS17347	H1	MIL-C-22992	R	Receptacle, jam nut
MS17348	**	MIL-C-22992	R	Receptacle, jam nut, box mount
MS18062	**	MIL-C-22992	R	Dummy receptacle
MS20026	*	MIL-C-27599		Receptacle, wall mount solder
MS20027	*	MIL-C-27599		Receptacle, In-line

* Consult factory for assistance

** Connector does not have rear accessory accommodations.

Military Standard Connector Matrix

Connector matrix

Part number	Sunbank connector designator	Specification	Series	Description
MS20028	*	MIL-C-27599		Plug, straight
MS20029	**	MIL-C-27599		Receptacle, jam nut mount
MS20030	**	MIL-C-27599		Receptacle, box mount, hermetic
MS20031	**	MIL-C-27599		Receptacle, jam nut, hermetic
MS20032	**	MIL-C-27599		Receptacle, solder mount, hermetic
MS20034	*	MIL-C-27599		Receptacle, wall mount
MS20035	*	MIL-C-27599		Receptacle, box mount
MS24264	D1	MIL-C-26500	F, G, R	Receptacle, flange mount
MS24265	D1	MIL-C-26500	F, G, R	Receptacle, single hole mount
MS24266	D1	MIL-C-26500	F, G, R	Plug, straight
MS25183	**	MIL-C-5015	MS3100	Plug, potting seal
MS27034	**	MIL-C-26500		Receptacle, hermetic, solder mount
MS27334	**	MIL-C-27599		Receptacle, wall mount
MS27335	**	MIL-C-27599		Receptacle, box mount
MS27336	*	MIL-C-27599		Plug, straight
MS27337	*	MIL-C-27599		Receptacle, jam nut
MS27338	*	MIL-C-27599		Receptacle, wall mount, hermetic
MS27339	**	MIL-C-27599		Receptacle, box mount, hermetic
MS27340	**	MIL-C-27599		Receptacle, jam nut mtg., hermetic
MS27341	**	MIL-C-27599		Receptacle, solder mount, hermetic
MS27466	F3	MIL-C-38999	I	Receptacle, wall mount
MS27467	F3	MIL-C-38999	I	Plug, straight
MS27468	F3	MIL-C-38999	I	Receptacle, jam nut
MS27469	F3	MIL-C-38999	I	Receptacle, wall mount, hermetic
MS27470	F3	MIL-C-38999	I	Receptacle, jam nut, hermetic
MS27471	F3	MIL-C-38999	I	Receptacle, solder mount hermetic
MS27472	F3	MIL-C-38999	II	Receptacle, wall mount
MS27473	F3	MIL-C-38999	II	Plug, straight

* Consult factory for assistance

** Connector does not have rear accessory accommodations.

Military Standard Connector Matrix

Connector matrix

Part number	Sunbank connector designator	Specification	Series	Description
MS27474	F3	MIL-C-38999	II	Receptacle, jam nut
MS27475	F3	MIL-C-38999	II	Receptacle, wall mount
MS27476	F3	MIL-C-38999	II	Receptacle, box mount hermetic
MS27477	F3	MIL-C-38999	II	Receptacle, jam nut, hermetic
MS27478	F3	MIL-C-38999	II	Receptacle, solder mount hermetic
MS27479	F3	MIL-C-38999	II	Inactive use MS27472
MS27480	F3	MIL-C-38999	II	Inactive use MS27473
MS27481	F3	MIL-C-38999	II	Inactive use MS27474
MS27482	F3	MIL-C-38999	II	Inactive use MS27475
MS27483	F3	MIL-C-38999	II	Inactive use MS27477
MS27484P	F3	MIL-C-38999	II	Plug, straight
MS27484T	F3	MIL-C-38999	II	Plug, straight
MS27496	F3	MIL-C-38999	I	Receptacle, box mount
MS27497	F3	MIL-C-38999	II	Receptacle, back panel wall mount
MS27498	F3	MIL-C-38999	I	Plug, 90 degree
MS27499	F3	MIL-C-38999	II	Receptacle, box mount
MS27500	F3	MIL-C-38999	II	Inactive use MS27473
MS27503	**	MIL-C-38999	II	Inactive use MS27478
MS27504	**	MIL-C-38999	II	Inactive use MS27499
MS27505	**	MIL-C-38999	I	Receptacle, back panel box mount
MS27508	**	MIL-C-38999	II	Receptacle, back panel box mount
MS27513	**	MIL-C-38999	II	Receptacle, box mount
MS27515	**	MIL-C-38999	I	Inactive use MS27656
MS27613	N1	MIL-C-26500K		Receptacle, panel mount
MS27614	N1	MIL-C-26500K		Receptacle, D-hole mount
MS27615	N1	MIL-C-26500K		Plug, straight
MS27652	F3	MIL-C-38999	I	Inactive use MS27466
MS27653	F3	MIL-C-38999	I	Inactive use MS27467

* Consult factory for assistance

** Connector does not have rear accessory accommodations.

Military Standard Connector Matrix

Connector matrix

Part number	Sunbank connector designator	Specification	Series	Description
MS27654	F3	MIL-C-38999	I	Inactive use MS27656
MS27656	F3	MIL-C-38999	III	Receptacle, back panel, wall mount
MS27661	*	MIL-C-38999	I	Plug, lanyard release
MS27662	**	MIL-C-38999	I	Receptacle, thru-bulkhead
MS27664	F3	MIL-C-38999	II	Receptacle, back panel wall mount
MS27665	F3	MIL-C-38999	I	Plug, rack & panel mount
MS27667	**	MIL-C-38999	II	Receptacle, thru-bulkhead
MS90555	*	MIL-C-22992	I	Receptacle, wall mount
MS90556	*	MIL-C-22992	I	Plug, straight
MS90557	*	MIL-C-22992	I	Plug, cable connecting
MS90558	*	MIL-C-22992	I	Receptacle, w/coupling ring, wall mount
M28840/10	U1	MIL-C-28840		Receptacle, wall mount
M28840/11	U1	MIL-C-28840		Receptacle, cable connecting
M28840/12	U1	MIL-C-28840		Receptacle, box mount
M28840/14	U1	MIL-C-28840		Receptacle, jam nut
M28840/16	U1	MIL-C-28840		Plug, straight
D38999/20	F5	MIL-C-38999	III	Receptacle, wall mount
D38999/21	**	MIL-C-38999	III	Receptacle, hermetic
D38999/23	**	MIL-C-38999	III	Receptacle, hermetic, jam nut
D38999/24	F5	MIL-C-38999	III	Receptacle, jam nut
D38999/25	**	MIL-C-38999	III	Receptacle, hermetic, solder mount
D38999/26	F5	MIL-C-38999	III	Plug, straight
D38999/27	**	MIL-C-38999	III	Receptacle, hermetic, weld mount
D38999/29	*	MIL-C-38999	III	Plug, lanyard release
D38999/30	*	MIL-C-38999	III	Plug, lanyard release
D38999/31	F5	MIL-C-38999	III	Plug, lanyard release
D38999/34	F5	MIL-C-38999	III	Receptacle, jam nut
D38999/35	F5	MIL-C-38999	III	Receptacle, wall mount

* Consult factory for assistance

** Connector does not have rear accessory accommodations.

Military Standard Connector Matrix

Connector matrix

Part number	Sunbank connector designator	Specification	Series	Description
D38999/40	F5	MIL-C-38999	IV	Receptacle, wall mount
D38999/41	**	MIL-C-38999	IV	Receptacle, box mount hermetic
D38999/42	**	MIL-C-38999	IV	Receptacle, box, mount
D38999/43	**	MIL-C-38999	IV	Receptacle, jam nut, mount hermetic
D38999/44	*	MIL-C-38999	IV	Receptacle, jam nut
D38999/45	**	MIL-C-38999	IV	Receptacle, solder mount, hermetic
D38999/46	F5	MIL-C-38999	IV	Plug, straight, EMI
D38999/47	F5	MIL-C-38999	IV	Plug, straight
D38999/48	**	MIL-C-38999	IV	Receptacle, weld mount, hermetic
D38999/49	F4	MIL-C-38999	IV	Receptacle, in-line
M81511/1	G1	MIL-C-81511	2	Receptacle, flange mount
M81511/2	**	MIL-C-81511	2	Receptacle, solder flange
M81511/3	G1	MIL-C-81511	2	Receptacle, jam nut
M81511/4	**	MIL-C-81511	2	Receptacle, jam nut
M81511/5	G1	MIL-C-81511	2	Plug, cable connecting
M81511/6	G1	MIL-C-81511	2	Plug
M81511/21	G1	MIL-C-81511	1	Receptacle, flange mount
M81511/22	**	MIL-C-81511	1	Receptacle, solder flange mount
M81511/23	G1	MIL-C-81511	1	Receptacle, jam nut
M81511/24	**	MIL-C-81511	1	Receptacle, jam nut
M81511/25	G1	MIL-C-81511	1	Receptacle, cable connecting
M81511/26	G1	MIL-C-81511	1	Plug
M81511/27	**	MIL-C-81511	1	Receptacle thru-bulkhead, jam nut
M81511/28	**	MIL-C-81511	2	Receptacle, thru-bulkhead, single hole mount
M81511/31	G1	MIL-C-81511	2	Receptacle, flange mount
M81511/32	G1	MIL-C-81511	2	Receptacle, jam nut mount
M81511/33	G1	MIL-C-81511	2	Receptacle, cable connecting
M81511/34	G1	MIL-C-81511	2	Plug

* Consult factory for assistance

** Connector does not have rear accessory accommodations.

Military Standard Connector Matrix

Connector matrix

Part number	Sunbank connector designator	Specification	Series	Description
M81511/35	G1	MIL-C-81511	1	Receptacle, flange mount
M81511/36	G1	MIL-C-81511	1	Receptacle, jam nut
M81511/37	G1	MIL-C-81511	1	Receptacle, cable connecting
M81511/38	G1	MIL-C-81511	1	Plug
M81511/41	G1	MIL-C-81511	3	Receptacle, flange mount
M81511/42	**	MIL-C-81511	2	Receptacle, solder flange mount
M81511/44	**	MIL-C-81511	3	Receptacle, jam nut
M81511/45	G1	MIL-C-81511	3	Receptacle, cable connecting
M81511/46	G1	MIL-C-81511	3	Plug
M81511/47	**	MIL-C-81511	3	Receptacle, solder flange mount
M81511/48	**	MIL-C-81511	3	Receptacle, jam nut
M81511/49	G1	MIL-C-81511	3	Receptacle, jam nut
M81511/50	**	MIL-C-81511	4	Receptacle, jam nut
M81511/51	G1	MIL-C-81511	4	Receptacle, flange mount
M81511/52	**	MIL-C-81511	4	Receptacle, solder flange mount
M81511/53	G1	MIL-C-81511	4	Receptacle, jam nut
M81511/54	**	MIL-C-81511	4	Receptacle, jam nut
M81511/55	G1	MIL-C-81511	4	Receptacle, cable connecting
M81511/56	G1	MIL-C-81511	4	Plug
M81511/57	**	MIL-C-81511	4	Receptacle, solder flange mount
M81582/1	*	MIL-C-81582		Receptacle, single hole mount
M81582/2	*	MIL-C-81582		Plug, lanyard release
M83723/1	A1	MIL-C-83723	I	Superseded by MS3470
M83723/2	A1	MIL-C-83723	I	Superseded by MS3470
M83723/3	A1	MIL-C-83723	I	Superseded by MS3472
M83723/4	A1	MIL-C-83723	I	Superseded by MS3472
M83723/5	A1	MIL-C-83723	I	Superseded by MS3474
M83723/6	A1	MIL-C-83723	I	Superseded by MS3474

* Consult factory for assistance

** Connector does not have rear accessory accommodations.

Military Standard Connector Matrix

Connector matrix

Part number	Sunbank connector designator	Specification	Series	Description
M83723/7	A1	MIL-C-83723	I	Superseded by MS3471
M83723/8	A1	MIL-C-83723	I	Superseded by MS3471
M83723/9	**	MIL-C-83723	I	Superseded by MS3440
M83723/10	**	MIL-C-83723	I	Superseded by MS3442
M83723/11	**	MIL-C-83723	I	Superseded by MS3443
M83723/12	**	MIL-C-83723	I	Superseded by MS3443
M83723/13	A1	MIL-C-83723	I	Superseded by MS3476
M83723/14	A1	MIL-C-83723	I	Superseded by MS3476
M83723/17	P1	MIL-C-83723	II	Superseded by MS3451
M83723/18	P1	MIL-C-83723	II	Superseded by MS3451
M83723/19	P1	MIL-C-83723	II	Superseded by MS3450
M83723/20	P1	MIL-C-83723	II	Superseded by MS3450
M83723/17	P1	MIL-C-83723	II	Superseded by MS3451
M83723/18	P1	MIL-C-83723	II	Superseded by MS3451
M83723/19	P1	MIL-C-83723	II	Superseded by MS3450
M83723/20	P1	MIL-C-83723	II	Superseded by MS3450
M83723/21	**	MIL-C-83723	II	Superseded by MS3452
M83723/22	**	MIL-C-83723	II	Superseded by MS3452
M83723/23	P1	MIL-C-83723	II	Superseded by MS3456
M83723/24	P1	MIL-C-83723	II	Superseded by MS3456
M83723/25	**	MIL-C-83723	II	Superseded by MS3142
M83723/26	**	MIL-C-83723	II	Superseded by MS3143
M83723/36	A1	MIL-C-83753	I	Inactive for new design
M83723/37	A1	MIL-C-83723	I	Inactive for new design
M83723/38	A1	MIL-C-83723	I	Inactive for new design
M83723/39	A1	MIL-C-83723	I	Inactive for new design
M83723/40	A1	MIL-C-83723	I	Inactive for new design
M83723/41	A1	MIL-C-83723	I	Inactive for new design

* Consult factory for assistance

** Connector does not have rear accessory accommodations.

Military Standard Connector Matrix

Connector matrix

Part number	Sunbank connector designator	Specification	Series	Description
M83723/42	A1	MIL-C-83723	I	Superseded by MS3475
M83723/43	A1	MIL-C-83723	I	Superseded by MS3475
M83723/45	**	MIL-C-83723	I	Superseded by MS3115
M83723/49	A1	MIL-C-83723	I	Inactive for new design
M83723/52	P1	MIL-C-83723	II	Superseded by MS3459
M83723/53	P1	MIL-C-83723	II	Superseded by MS3459
M83723/65	A1	MIL-C-83723	III	Receptacle, jam nut (pin contacts)
M83723/66	A1	MIL-C-83723	III	Plug, push pull (pin contacts)
M83723/67	A1	MIL-C-83723	III	Plug, push pull (socket contacts)
M83723/48	A1	MIL-C-83723	I	Inactive for new design
M83723/68	A1	MIL-C-83723	III	Plug, push pull lanyard (pin contacts)
M83723/69	A1	MIL-C-83723	III	Plug, push pull, lanyard (socket contacts)
M83723/71	A1	MIL-C-83723	III	Receptacle, bayonet, flange mount (socket contacts)
M83723/72	A1	MIL-C-83723	III	Receptacle, bayonet, flange mount (pin contacts)
M83723/73	A1	MIL-C-83723	III	Receptacle, bayonet, single hole mount (socket contacts)
M83723/74	A1	MIL-C-83723	III	Receptacle, bayonet, single hole mount (pin contacts)
M83723/75	A1	MIL-C-83723	III	Plug, bayonet (socket contacts)
M83723/76	A1	MIL-C-83723	III	Plug, bayonet (pin contacts)
M83723/77	A1	MIL-C-83723	III	Plug, bayonet, RFI (socket contacts)
M83723/78	A1	MIL-C-83723	III	Plug, bayonet, RFI (pin contacts)
M83723/79	**	MIL-C-83723	III	Receptacle, bayonet flange mount hermetic
M83723/80	**	MIL-C-83723	III	Receptacle, bayonet solder flange mount hermetic
M83723/81	**	MIL-C-83723	III	Receptacle, bayonet single hole mount, hermetic
M83723/82	A1	MIL-C-83723	III	Receptacle, threaded, flange mount (socket contacts)
M83723/83	A1	MIL-C-83723	III	Receptacle, threaded, flange mount (pin contacts)
M83723/84	A1	MIL-C-83723	III	Receptacle, threaded single hole mount (socket contacts)
M83723/85	A1	MIL-C-83723	III	Receptacle, threaded single hole mount (pin contacts)
M83723/86	A1	MIL-C-83723	III	Plug, threaded, (socket contacts)

* Consult factory for assistance

** Connector does not have rear accessory accommodations.

Military Standard Connector Matrix

Connector matrix

Part number	Sunbank connector designator	Specification	Series	Description
M83723/87	A1	MIL-C-83723	III	Plug, threaded, (pin contacts)
M83723/88	**	MIL-C-83723	III	Receptacle, threaded, flange mount (pin contacts)
M83723/89	**	MIL-C-83723	III	Receptacle, threaded, single hole mount, hermetic
M83723/90	**	MIL-C-83723	III	Receptacle, threaded, solder flange mount, hermetic
M83723/91	A1	MIL-C-83723	III	Plug, threaded, RFI (socket contacts)
M83723/92	A1	MIL-C-83723	III	Plug, threaded, RFI (pin contacts)
M83723/93	**	MIL-C-83723	III	Receptacle, bayonet, solder flange mount, hermetic
M83723/94	**	MIL-C-83723	III	Receptacle, bayonet, single hole mount, hermetic
M83723/95	A1	MIL-C-83723	III	Plug, threaded, (socket contacts), self-locking
M83723/96	A1	MIL-C-83723	III	Plug, threaded, (pin contacts), self-locking
M83723/97	A1	MIL-C-83723	III	Plug, threaded, RFI (socket contacts), self-locking
M83723/98	A1	MIL-C-83723	III	Plug, threaded, RFI (pin contacts), self-locking
NB0	A1	40M39569		Receptacle, flange mount
NB0H	**	40M39569		Receptacle, hermetic
NB3H	**	40M39569		Receptacle, hermetic
NB4	A1	40M39569		Receptacle, flange mount
NB5H	**	40M39569		Thru-bulkhead, hermetic
NB6	A1	40M39569		Plug, straight
NB6G	A1	40M39569		Plug, straight, EMI
NB7	A1	40M39569		Receptacle, jam nut
NB7H	**	40M39569		Receptacle, hermetic
NB8H	**	40M39569		Receptacle, hermetic
NLS0	F3	40M38277		Receptacle, flange mount
NLS3H	**	40M38277		Receptacle, hermetic
NLS6	F3	40M38277		Plug, straight
NLS6G	F3	40M38277		Plug, straight, EMI
NLS7	F3	40M38277		Receptacle, jam nut
NLS7H	**	40M38277		Receptacle, jam nut

* Consult factory for assistance

** Connector does not have rear accessory accommodations.

Manufacturer Connector Matrix

Connector matrix

Connector manufacturer	Mfg. series	Sunbank series	Specification reference	Connector series	Document control	
					US	Europe
Aero-Electric Connector	AE22	F5	MIL-C-38999	III	X	
	AE46 & AE49	F3	MIL-C-38999	I	X	
	AE47 & AE48	F3	MIL-C-38999	II	X	
	AE55	A1	MIL-C-5015	MS3400	X	
	AE66	D1	MIL-C-26500	Alum	X	
	AE77	A1	MIL-C-26482	II	X	
Amphenol Limited and Amphenol-Tuchel Electronics GmbH	62GB	A4	PATT 105		X	
	118	A1	LN29504		X	
	162GB	A4	PATT 603			X
	348	G1	VG 95329			X
	418-1	F3	PATT 616			X
	JT	F3	PAN 6433-1			X
	418-2	F3	PATT 614			X
	SJT	X1	LN 29729, PAN 6433-2, EN 3372			X
	SJT	X1	PATT 615 & VG96912			X
	418-5	X1	PATT 615 & NFC 93422	HE 306		X
	602GB	A1	PAN 6432-1, DEF 5326-3			X
602GB	A1	PATT 602, Def Std 59-35			X	
652	A1	LN 29504			X	
Amphenol Products	48	D1	MIL-C-26500	Alum	X	
	69	A2	MIL-C-5015	MS3100	X	
	97	A2	MIL-C-5015	MS3100	X	
	118	A1	MIL-C-26482	II	X	
	118	A1	MIL-C-83723	I	X	
	348	G1	MIL-C-81511	I and II	X	
	418-1	F3	MIL-C-38999	I	X	
	418-2	F3	MIL-C-38999	II	X	
	518	A1	MIL-C-83723	III	X	
Amphenol Products/ Bendix ECD	BG	E1	MIL-C-26482	I	X	

Manufacturer Connector Matrix

Connector matrix

Connector manufacturer	Mfg. series	Sunbank series	Specification reference	Connector series	Document control	
					US	Europe
Amphenol Products/ Bendix ECD	JT-R	F3	MIL-C-38999 and 40M38277	II	X	
	LJT-R	F3	MIL-C-38999 and PATT 614	I	X	X
	MF-S	E1	MIL-C-26482	I	X	
	PT	E1	MIL-C-26482	I	X	
	PT-SE	E1	MIL-C-26482	I	X	
	PTS-DR	A1	MIL-C-26482 and MIL-C-83723	I and II	X	
	QWLD	H1	MIL-C-22922		X	
	SC	A2	MIL-C-5015	MS3100	X	
	SM	A2	MIL-C-5015	MS3100	X	
	TV	F4	MIL-C-38999	III	X	
	TVS	F4	MIL-C-38999 and EN 3645	III	X	X
	10-72	A2	MIL-C-5015	MS3100	X	
	10-214	A2	MIL-C-5015	MS3100	X	
	10-475	F3	40M38277		X	
	71	A2	MIL-C-5015	MS3100	X	
91-483	A1	MIL-C-26482 and MIL-C-83723	I and II	X		
Burndy Corporation (Framatone U.S.)	BT	E1	MIL-C-26482	I	X	
	SOURIAU	E1	MIL-C-26482	I	X	
	L	E1	MIL-C-26482	I	X	
	L-T	E1	MIL-C-26482	I	X	
	M-T	E1	MIL-C-26482	I	X	
Cannon Electric (GB) Limited	KJ	F3	PATT 614, PAN 6433-1 and MIL-C-38999	II	X	X
	KJ	F3	40M38277		X	
Cannon Electric France SA	KPSE	E1	MIL-C-26482	I	X	
Cannon Electric GmbH	KV-S	A1	MIL-C-83723	I	X	
ITT Cannon	PVW	A1	LN 29504			X
	PVX	A1	PAN 6432-1 and PATT 602			X
	PVX	A1	EN 2997			X
	PVA	A1	MIL-C-83723	I	X	

Manufacturer Connector Matrix

Connector matrix

Connector manufacturer	Mfg. series	Sunbank series	Specification reference	Connector series	Document control	
					US	Europe
ITT Cannon (continued)		PV7	A1	MIL-C-26482	I	X
	KJL	F3	MIL-C-38999	I	X	
	CGK	X1	LN 29729, EN3372, PAN6433-2 and VG96912			X
	MF	A1	MIL-C-83723	III	X	
	KFS	U1	MIL-C-28840		X	
	CVA	P1	MIL-C-83723	II	X	
	KJA	F4	MIL-C-38999 and EN3645	III	X	
	PV-G	A1	40M39569		X	
	KPT	E1	MIL-C-26482	I	X	
	CV	A1	MIL-C-5015	MS3400	X	
	CA-RX	A2	MIL-C-5015	MS3100	X	
	CA-E/R	A2	MIL-C-5015	MS3100	X	
	CWLD	H1	MIL-C-22992	R	X	
	Cie Deutsch & Compagnie Deutsch GmbH and Deutsch Engineered Connecting Devices	AFD5	A1	MIL-C-26482	II	X
AFD		A1	MIL-C-83723, LN 29504 and PAN 6432-1	I	X	X
A815		G1	MIL-C-81511	IV	X	
B815		G1	MIL-C-81511	III	X	
DBAS		A1	MIL-C-81703 and PAN 6432-2	III	X	
DFE		A1	LN 29504 and MIL-C-26482	II	X	X
DVG		A1	VG95328			X
FDBA		A1	LN 29504			X
951		A1	PRL 53125 and LN 29500			X
9.815		G1	MIL-C-81511	III and IV	X	
991		A1	PAN 6432-4	X		
999.1		F3	MIL-C-38999	I		X
BTK		E1	MIL-C-26482	I	X	
DBA		A1	40M39569		X	
DBA7		A1	MIL-C-81703	III	X	
DTS		F4	MIL-C-38999	III	X	

Manufacturer Connector Matrix

Connector matrix

Connector manufacturer	Mfg. series	Connector series	Specification reference	Connector series	Document control	
					US	Europe
Deutsch (continued)		DIV4	F4	MIL-C-38999	IV	X
	DL6	A1	MIL-C-83723	III	X	
	D817	A1	MIL-C-81703	III	X	
	LPT	E1	MIL-C-26482	I	X	
	381	A1	40M39569	X		
	450	E1	MIL-C-26482	I	X	
	460	E1	MIL-C-26482	I	X	
	837	A1	MIL-C-83723	III	X	
Hellerman Deutsch	LL	G1	MIL-C-81511	III and IV	X	
	RR	A1	PAN 6432-1 and PATT602			X
	DBAS	A1	PAN 6432-2			X
	RR70	A1	MIL-C-81703	III	X	
	DTS	F4	MIL-C-38999	III	X	
GandH Technology	BL	F4	MIL-C-38999	III	X	
	NC	U1	MIL-C-28840		X	
AB Electronics	CT-R	F3	MIL-C-38999	II	X	
	MK 8	A4	PATT 105			X
	MK 12	A4	PATT 603			X
	MK 18	A4	PATT 608			X
SOURIAU	8T	F3	MIL-C-38999	II	X	
	8LT	F3	MIL-C-38999	I	X	
	8D	F4	MIL-C-38999 and EN3645	IV	X	X
	JVS	F4	MIL-C-38999	III	X	
	8533	A1	EN 2997			X
	83723	A1	MIL-C-83723	III	X	
	851	A4	MIL-C-26482 (Class R), PATT 603	I	X	X
	8526	A1	PATT 602, PAN 6432-1			X
8526	A1	MIL-C-26482	II	X		
FCI (TEC Limited)	8LT	F3	NFC 93422	HE 308		X

Manufacturer Connector Matrix

Connector matrix

Connector manufacturer	Mfg. series	Connector series	Specification reference	Connector series	Document control	
					US	Europe
SOURIAU	8ST	X1	LN 29729, NFC 93422, PAN 6433-2	HE 306		X
	8ST	X1	PATT 615, VG 96912 and EN 3372			X
	8T	F3	NFC 93422 and MIL-C-38999 Series II	HE 309	X	X
	8525	A1	NFC 93422	HE 302		X
	8525-1	A1	LN 29504			X
	8526	A1	PAN 6432-1 and PATT 602			X
FKI Limited	TT	F3	PAN 6433-1 and MIL-C-38999	II	X	X
	VTT	F4	MIL-C-38999	III	X	
	LTT	F3	MIL-C-38999	I	X	
	PT	A4	PATT 105			X
	PT-SE	A4	PATT 603			X
	STT	X1	LN 29729, PAN 6433-2			X
	STT	X1	PATT 615 and VG96912			X
Veam Litton Precision Products Int'l.	VPT	E1	MIL-C-26482	I	X	
Pyle National	B	A1	MIL-C-83723	III	X	
	T3	F4	MIL-C-38999 and EN3645	III	X	
	BTC	A1	EN 2997			X
	ET 1	A1	NAS1599		X	
	ZZW	D1	MIL-C-26500	ALUM	X	
	ZZY	D1	MIL-C-26500	ALUM	X	
Schaltbau GmbH	650	G1	VG 95329			X
	679	G1	VG 95329			X
Matrix Science Corp. (AMP)	MB1	A1	MIL-C-26482 and MIL-C-83723	I and II	X	
	MB3	A1	MIL-C-83723	III	X	
	MB91	F3	MIL-C-38999	I	X	
	MB92	F3	MIL-C-38999	II	X	
	MB93	F4	MIL-C-38999	III	X	
	MD	A1	MIL-C-26482	II	X	
	ML94	F4	MIL-C-38999	IV	X	

Manufacturer Connector Matrix

Connector matrix

Connector manufacturer	Mfg. series	Connector series	Specification reference	Connector series	Document control	
					US	Europe
Matrix Science Corp. (AMP)	MQ3	A1	MIL-C-83723	III	X	
	MBL	A1	NFC 93422	HE 302		X
	MTE	A1	EN 2997			X
	MT3	A1	MIL-C-83723	III	X	
	M723	P1	MIL-C-83723	II	X	
	944	A1	MIL-C-5015	MS3400	X	
	9816	A1	MIL-C-5015	MS3400	X	
Flight Connector Corporation	FF	A1	MIL-C-5015	MS3400	X	
	FHA	P1	MIL-C-83723	II	X	
Elecsys	PL	F4	MIL-C-38999	IV	X	
	RDN	U1	MIL-C-28840		X	
Midland Ross SAE Connectors (no longer in business)	HD	U1	MIL-C-28840		X	
	HM	F3	MIL-C-38999	I and II	X	
	HM	F4	MIL-C-38999	III		
	SA340	A1	MIL-C-5015	MS3400	X	
	SA345	A1	MIL-C-5015	MS3450	X	
TRW (Cinch) Labinal	CN09	A1	MIL-C-83723	III	X	
	CN0	F4	MIL-C-38999	III	X	
	48	D1	MIL-C-26500	ALUM	X	
Hughes CDC	GT	U1	MIL-C-28840		X	

Materials and tolerances

Material type	Material	Specification
Machined components	Aluminum alloy	QQ-A-225, ASTM B211, ASTM B221
Die cast components	Aluminum alloy	QQ-A-591, ASTM B85 (A380)
Corrosion resistant steel machined components	Stainless steel	ASTM A581, AMS 5640, QQ-S-763 (300 Series)
Corrosion resistant steel castings	Stainless steel	ASTM A743/A 743M, QQ-S-763 (300 Series)
Elastomer components	Silicone	ZZ-R-765
Hardware components	Stainless steel	QQ-S-763 (300 Series)

Notes

Tolerance

Unless otherwise specified:

- .X ± .060 (1.5)
- .XX ± .030 (0.8)
- .XXX ± .015 (0.4)
- Angles ± 5 degrees

Sunbank Standard Plating Finishes

Table II

Sunbank designator	Finish	Specification
C	Cadmium plate, olive drab	QQ-P-416, Type II, Class 3
N	Electroless nickel	ASTMB733-90, SC2, Type I, Class 5
CN	Cadmium plate, olive drab over electroless nickel	500 - Hr. corrosion protection
A *	Hard anodize	MIL-A-8625, Type III, Class 1
AB *	Anodize, black	MIL-A-8625, Type II, Class 2
CC	Cadmium plate, clear/bright	QQ-P-416, Type II, Class 3
CE	Cadmium plate, clear/bright over electroless nickel	500 - Hr. corrosion protection
CB	Cadmium plate, black	QQ-P-416, Type II, Class 3
P ***	Passivate	QQ-P-35 or ASTM A967
PN	Electroless nickel over stainless steel material	ASTMB733-90, SC2, Type I, Class 4
PC	Cadmium plate, olive drab over stainless steel material	QQ-P-416, Type II, Class 3
GI	Iridite, gold/yellow	MIL-C-5541, Class 3
CS **	Cadmium plate, olive drab termination platform electroless nickel	500 - Hr. corrosion protection
Z	Zinc cobalt, dark olive drab color	96- Hr. corrosion protection
ZB	Zinc cobalt, black color	96- Hr. corrosion protection
FN	EN-PTFE, Polytetrafluoroethylene	AMS 2454
ZF	Zinc Nickel Black	ASTM, Class 1, Type D, Grade 5
ZN	Zinc Nickel Olive Drab	ASTMB 841, Class 1, Grade 5

* Anodize finishes not suited for EMI/RFI shielding or grounding applications.

** Barrier sealant stripes are used to isolate the finish materials.

*** Applicable to corrosion resistant steel backshells only. Consult factory for product availability.

Sunbank Connector Accessory Interface Standards

Table I

A thread reference	B dia. max	C hex** size	D hex** size	Connection series designator								
				A1	F2	F3	F4	F5	L1	X1*	X2*	
.438-28 UNEF	0.767 (19.5)	0.625 (15.9)	0.750 (19.1)		8	8 (9)					8	8
M12X1-6H	0.767 (19.5)	0.625 (15.9)	0.750 (19.1)				9 (A)	9 (A)				
.500-20 UNF	0.675 (17.1)	0.625 (15.9)		8						8		
.562-24 UNEF	0.905 (23.0)	0.750 (19.1)	0.875 (22.2)		10	10 (11)					10 (8)	10 (8)
M15X1-6H	0.905 (23.0)	0.750 (19.1)	0.875 (22.2)				11 (B)	11 (B)				
.625-24 UNEF	0.812 (20.6)	0.750 (19.1)		10						10		
.688-24 UNEF	1.017 (25.8)	0.875 (22.2)	1.000 (25.4)		12	12 (13)					12 (10)	12 (10)
M18X1-6H	1.017 (25.8)	0.875 (22.2)	1.000 (25.4)				13 (C)	13 (C)				
750-20 UNEF	0.927 (23.5)	0.875 (22.2)		12						12		
.812-20 UNEF	1.188 (30.2)	1.000 (25.4)	1.125 (28.6)		14	14 (15)					14 (12)	14 (12)
M22X1-6H	1.188 (30.2)	1.000 (25.4)	1.125 (28.6)				15 (D)	15 (D)				
.875-20 UNEF	1.043 (26.5)	1.000 (25.4)		14						14		
.938-20 UNEF	1.300 (33.0)	1.125 (28.6)	1.250 (31.8)		16	16 (17)					16 (14)	16 (14)
M25X1-6H	1.300 (33.0)	1.125 (28.6)	1.250 (31.8)				17 (E)	17 (E)				
1.000-20 UNEF	1.153 (29.3)	1.125 (28.6)		16						16		
1.062-18 UNEF	1.411 (35.8)	1.188 (30.2)	1.375 (34.9)	18	18	18 (19)				18	18 (16)	18 (16)
M28X1-6H	1.411 (35.8)	1.188 (30.2)	1.375 (34.9)				19 (F)	19 (F)				
1.188-18 UNEF	1.541 (39.1)	1.375 (34.9)	1.500 (38.1)	20	20	20 (21)				20	20 (18)	20 (18)
M31X1-6H	1.541 (39.1)	1.375 (34.9)	1.500 (38.1)				21 (G)	21 (G)				
1.312-18 UNEF	1.667 (42.3)	1.500 (38.1)	1.500 (38.1)	22	22	22 (23)				22	22 (20)	22 (20)
M34X1-6H	1.667 (42.3)	1.500 (38.1)	1.625 (41.3)				23 (H)	23 (H)				
1.438-18 UNEF	1.771 (45.0)	1.625 (41.3)	1.750 (44.5)	24	24	24 (25)				24	24(22 & 24)	24(22 & 24)
M37X1-6H	1.771 (45.0)	1.625 (41.3)	1.750 (44.5)				25 (J)	25 (J)				
1.750-18 UNS	1.884 (47.9)	1.875 (47.6)		28						28		

Notes

1 Metric dimensions are shown in parentheses for reference only.

* The SJT07 jam nut receptacle (connector codes X1 & X2) uses different threads per shell size. Therefore, the shell sizes shown in parentheses would apply. Care should be taken when selecting the correct combination backshell to connector shell size to avoid improper fit.

** Use C hex size designator for codes A1, F2, F3, F4, L1 & X1.
Use D hex size designator for codes F5 & X2.

Maximum Cable Diameters

Z diameter

Shell size	Connection series designator							
	A1	F2	F3	F4	F5	L1	X1*	X2*
08	0.265 (06.7)	0.269 (06.8)	0.269 (06.8)			0.267 (06.8)		0.269 (06.8)
09				0.269 (06.8)	0.294 (07.5)		0.269 (06.8)	
10	0.370 (09.4)	0.407 (10.3)	0.407 (10.3)			0.372 (09.4)		0.407 (10.3)
11				0.407 (10.3)	0.432 (11.0)		0.407 (10.3)	
12	0.506 (12.9)	0.521 (13.2)	0.524 (13.2)			0.501 (12.7)		0.521 (13.2)
13				0.521 (13.2)	0.558 (14.0)		0.521 (13.2)	
14	0.580 (14.7)	0.646 (16.4)	0.646 (16.4)			0.580 (14.7)		0.646 (16.4)
15				0.646 (16.4)	0.651 (16.5)		0.646 (16.4)	
16	0.705 (17.9)	0.765 (19.4)	0.765 (19.4)			0.702 (17.8)		0.765 (19.4)
17				0.765 (19.4)	0.776 (19.7)		0.765 (19.4)	
18	0.781 (19.8)	0.860 (21.8)	0.860 (21.8)			0.784 (19.9)		0.860 (21.8)
19				0.860 (21.8)	0.890 (22.6)		0.860 (21.8)	
20	0.909 (23.1)	0.980 (24.9)	0.980 (24.9)			0.909 (23.1)		0.980 (24.9)
21				0.980 (24.9)	0.995 (25.3)		0.980 (24.9)	
22	1.034 (26.3)	1.113 (28.3)	1.113 (28.3)			1.034 (26.3)		1.113 (28.3)
23				1.113 (28.3)	1.140 (29.0)		1.113 (28.3)	
24	1.149 (29.2)	1.235 (31.3)	1.235 (31.3)			1.149 (29.2)		1.235 (31.3)
25				1.235 (31.3)	1.237 (31.4)		1.235 (31.3)	
28	1.384 (35.2)					1.384 (35.2)		

Notes

- 1 Metric dimensions are shown in parentheses for reference only.
- 2 If cable diameter exceeds values, consult factory.

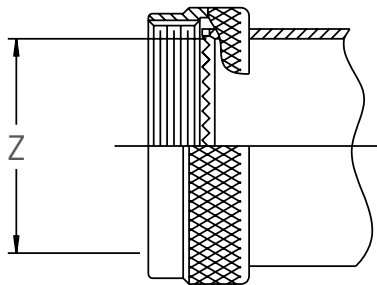

Modification codes

Mode code designator	Modification description
028	Assembly supplied with hex coupling nut
038	Assembly supplied with fluorosilicone elastomers
046	Assembly supplied with Buna-N elastomers
048	Assembly supplied less strain relief clamp or cable sealing nut
049	Internal surfaces to be coated with non-conductive abrasion resistant material for enhanced wire management feature.
114	Assembly supplied with a Sunband™
115	Assembly supplied with a constant force spring (CFS)

Example part number

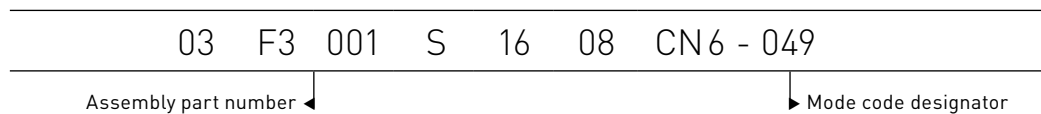

Notes

1 Consult factory for modification code availability for a given Product series.

Torque values

Connector shell size	Accessory thread torque ± 5 inch lbs	
	Category 1 light & medium duty	Category 2 heavy duty
A, 8, 9	40	70
B, 3, 10, 10SL, 11	40	95
C, 7, 12, 12S, 13	40	135
D, 14, 14S, 15	40	145
E, 16, 16S, 17	40	145
F, 18, 19, 27	40	145
G, 20, 21, 37	80	170
H, 22, 23	80	170
J, 24, 25, 61	80	170
28, 29	120	185
32, 33	120	185
36	120	185
40	170	205
44	170	205
48	170	205

Category 1

MIL-C-5015 (MS3100 Series)
 MIL-C-26482 Series 1
 MIL-C-26500
 MIL-C-27599
 MIL-C-38999 Series I & II
 MIL-C-81511 Series I, II, III, IV
 MIL-C-81703 Series 1

Category 2

MIL-C-5015 (MS3400 Series)
 MIL-C-22992
 MIL-C-26482 Series II
 MIL-C-28840
 MIL-C-38999 Series III & IV
 MIL-C-81703 Series I, II, III

Thread torque for cable clamp hardware

Screw size	Recommended maximum torque
4-40	6.4
6-32	12
8-32	13.6
10-32	19.2
1/4-20	51.2

Notes

Torque values for Category 1 are 80% of MIL-C-85049 light and medium duty thread strength.

Category 2 torque values are based on MIL-C-85049 heavy duty thread strength.

Cable clamp screw torque values are based on independent testing conducted at Sunbank.

Accessory to Shrink Boot

Reference information

Entry sizes								
Sunbank series 06**001	Sunbank series 06**008	Sunbank series 06**009	MS3109 (straight) Long		MS3117 (90 degree) Short		3M designator Long	
02			N/A	N/A	N/A	N/A	313D322-	N/A
	8	01, 02	-01	-11	-01	-11	313D322-	313D232-
04, 06	10	03, 04	-02	-12	-02	-12	313D332-	313D243-
08	12, 14	05 - 08	-03	-13	-03	-13	313D343-	313D253-
10	16, 18	09 - 11	-04	-14	-04	-14	313D353-	313D264-
14	20	12 - 14	-05	-15	-05	-15	313D364-	313D274-
16, 18	22		-06	-15	-06	-15	313D374-	313D274-
	24, 61	15, 16	-06	-16	-06	-16	313D374-	313D285-
20	28		-07	-16	-07	-16	313D385-	313D285-
		17	-07	-17	-07	-17	313D385-	313D296-
	32, 36		-08	-17	-08	-17	313D396-	313D296-
	40		-09	-18	-09	-18	313D407-	N/A
	44, 48		-10	-18	-10	-18	313D410-	N/A

Notes

Shrink boot part number information is given as a reference only for selecting the correct boot size for the adapter sizes listed. Shrink boot materials and configuration are application dependent, and should be specified by the user.

Suggested procedure

- 1 Temporarily assemble the adapter to the connector if you're using a product that requires EMI/RFI protection, environmental sealing protection or a combination of both. If not, refer to steps 7 and 10 only.
- 2 Place the remaining adapter components on the cable in the sequence shown on the individual product drawing. Keep these components away from the termination area so they do not interfere with subsequent assembly steps.
- 3 Insert cable into adapter and bottom against connector. Hold cable in position and mark outer shield (or jacket) at rear end of adapter.
- 4 Disassemble adapter from the connector and slide up cable with the other components.
- 5 Trim jacket (if applicable) approximately $\frac{1}{2}$ to $1\frac{1}{2}$ inches back from the mark making sure the jacket will be positioned under the elastic seal. For overall shields comb out and fold back up cable and tie or tape. For individual shields pigtail and flatten by hand then fold back onto cable and tie or tape.
- 6 Prepare and terminate the connector in accordance with standard practice.
- 7 Assemble the adapter onto the connector and tighten within the specific torque values shown on page 43 of this catalog. Note, it will not be necessary to align the adapters interfacial teeth with the connector. This product will self-align as you tighten securely to the connector.
- 8 Untie shield(s) and arrange evenly. Place shields over termination platform and terminate with proper tools. If using RFI rings, place the shield(s) over the cone or first ring and slide the remaining ring in to place and spot tie. Trim off excess shield.
- 9 For environmental assemblies, be sure the adapter containing the elastic seal is positioned above the cable jacket when securing the remaining adapter components.
- 10 Engage cable clamp or rear adapter onto the first adapter and tighten securely. Tighten saddle clamps around cable if applicable.

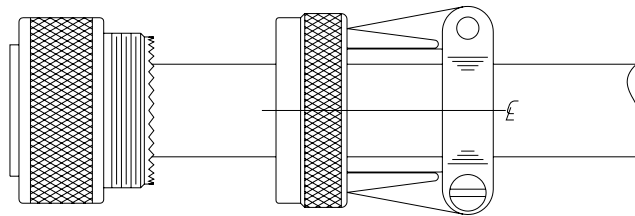



PRODUCT AND HARWARE

Self-seating Connector Accessories

PRODUCT AND HARDWARE

■ 03 Series Band Adapter Product Index	50
■ 06 Series Shrink Boot Adapter Products	74
■ 09 Series Strain Relief Adapter Products	86
■ 12 Series Adapter Extender Products	96
■ 15 Series Non-Environmental Adapter Products	100
■ 18 Series Environmental Adapter Products	104
■ 21 Series EMI/RFI Adapter Products	110
■ 24 Series EMI/RFI Environmental Adapter Products	128
■ 33 Series EMI/RFI S Spring Adapter Products	138
■ 36 Series Shorting Can Adapter Products	144
■ 39 Series Pipe Thread Adapter Products	148
■ 51 Series Lamp Base Adapter Products	152
■ 57 Series Commercial Conduit Adapter Products	158
■ 90 Series Accessory Hardware Products	162
■ 99 Series Assembly Tool Products	169

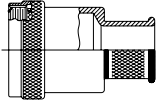
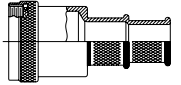
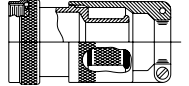
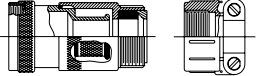
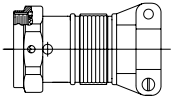
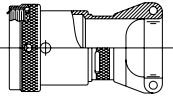
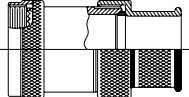
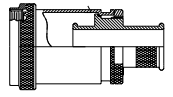
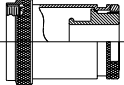
Basic part designator	Product page	Configuration description	
001 022	51 53	These products have a circular shape self-seating spin coupling nut and are an economical solution to terminating single or double over-all cable shields or individual cable shields where future repairability and maintainability are required. It provides a full 360 degree shield termination utilizing either Sunbank's banding system or constant force spring termination device.	
008 024	55 57	A banding accessory having a dual termination platform for termination overall cable shields and outer protective overbraids.	
009	59	A banding backshell assembly having a cable clamp that conceals the terminating platform and provides cable strain relief.	
010	61	A backshell that utilizes the Sunband™ termination technique with environmental sealing capabilities. Options for light and heavy duty cable clamps or sealing nut.	
011	63	These products have a shield termination platform that is designed to accept a hose clamp for terminating individual shields, in addition to providing strain relief for the wire bundle.	
013	65	A banding backshell with individual termination slots providing access for individual shields to be fed out from the interior of the accessory and terminated utilizing Sunbank's banding system, in addition to providing wire bundle strain relief.	
014	67	A backshell designed to terminate individual shields with a tapered ground ring which seats into a corresponding tapered surface in the backshell. This is followed by a transition adapter that secures the ring in place and provides a termination platform for overall cable shields utilizing Sunbank's banding system.	
015	69	This series combines the self-seating captive spin coupler feature with a low profile individual and overall shield termination banding platform. The main body can be removed without disturbing the termination area allowing for field repair or wire additions.	
016	71	This single series combines the self-seating captive spin coupler feature with a low profile individual shield termination banding platform. The main body retracts without disturbing the termination area allowing for field repair or wire additions.	

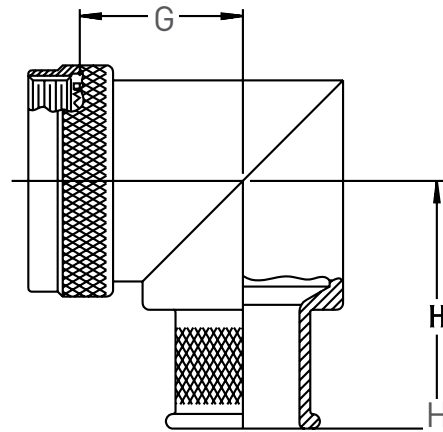
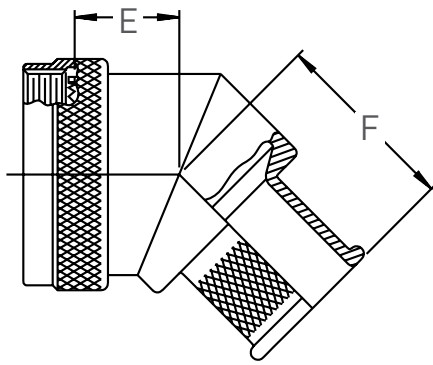
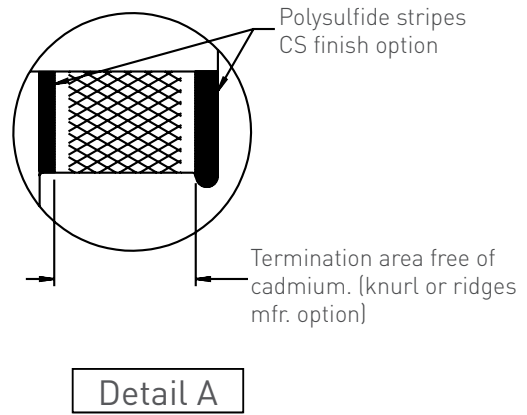
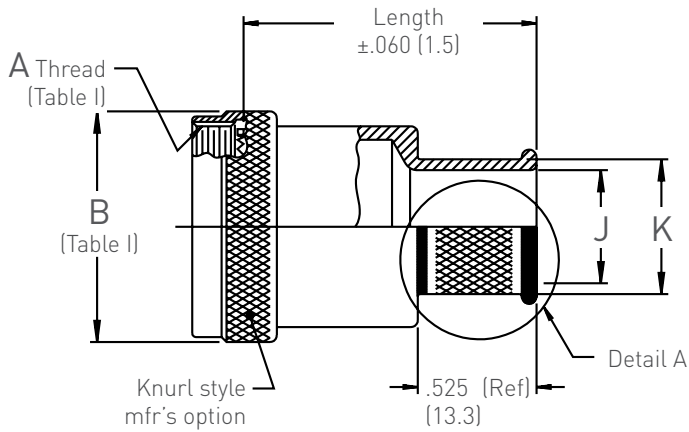

Example part number

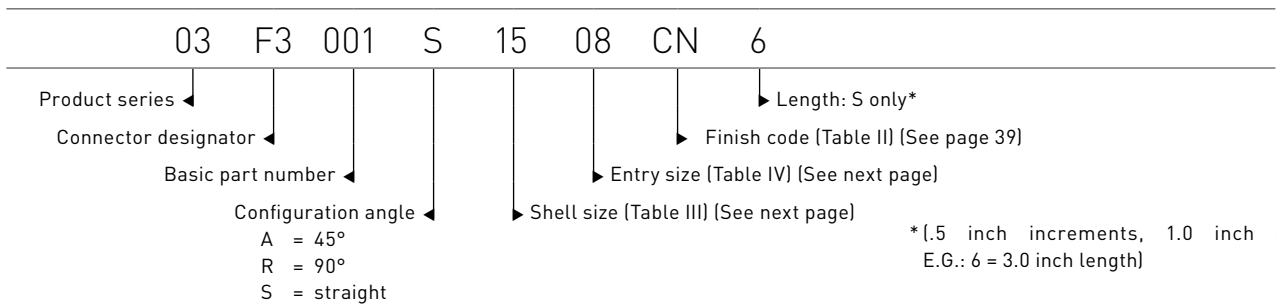

Table III

**Connector designator									
Shell size		E		F		G		H	
A1, F3, L1, X1	F4	Max dimension		Max dimension		Max dimension		Max dimension	
08	09	0.546	(13.9)	0.892	(22.7)	0.661	(16.8)	1.056	(26.8)
10	11	0.609	(15.5)	0.918	(23.3)	0.765	(19.4)	1.109	(28.2)
12	13	0.632	(16.1)	0.944	(24.0)	0.820	(20.8)	1.172	(29.8)
14	15	0.657	(16.7)	0.960	(24.4)	0.880	(22.4)	1.207	(30.7)
16	17	0.682	(17.3)	0.993	(25.2)	0.942	(23.9)	1.280	(32.5)
18	19	0.701	(17.8)	1.002	(25.5)	0.986	(25.0)	1.309	(33.2)
20	21	0.727	(18.5)	1.032	(26.2)	1.049	(26.6)	1.392	(35.4)
22	23	0.752	(19.1)	1.055	(26.8)	1.111	(28.2)	1.457	(37.0)
24	25	0.778	(19.8)	1.077	(26.4)	1.174	(29.8)	1.496	(38.0)

* For connector family identification details see Page 17, Section I. Consult factory for availability of other connector designators not shown above.

Table IV

Entry size	J diameter		K diameter	
02	0.125	(3.2)	0.221	(5.6)
04	0.250	(6.4)	0.346	(8.8)
06	0.375	(9.5)	0.471	(12.0)
08	0.500	(12.7)	0.596	(15.1)
10	0.625	(15.9)	0.721	(18.3)
12	0.750	(19.1)	0.846	(21.5)
14	0.875	(22.2)	0.971	(24.7)
16	1.000	(25.4)	1.096	(27.8)
18	1.125	(28.6)	1.221	(31.0)
20	1.250	(31.8)	1.346	(34.2)

Notes

- 1 Metric dimensions are shown in parentheses for reference only.
- 2 Consult factory when cable entry diameter exceeds Z diameter (see page 41).
- 3 See section 90 and 99 (pages 162 and 169) for band termination selection and application tool data

Tolerance

Unless otherwise specified:

.X ± .060 (1.5)

.XX ± .030 (0.8)

.XXX ± .015 (0.4)

Angles ± 5 degrees

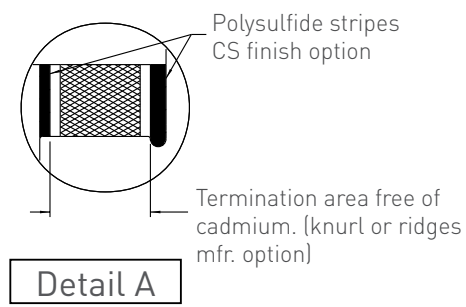
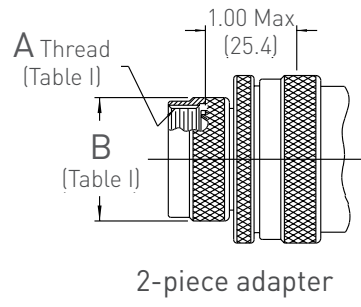
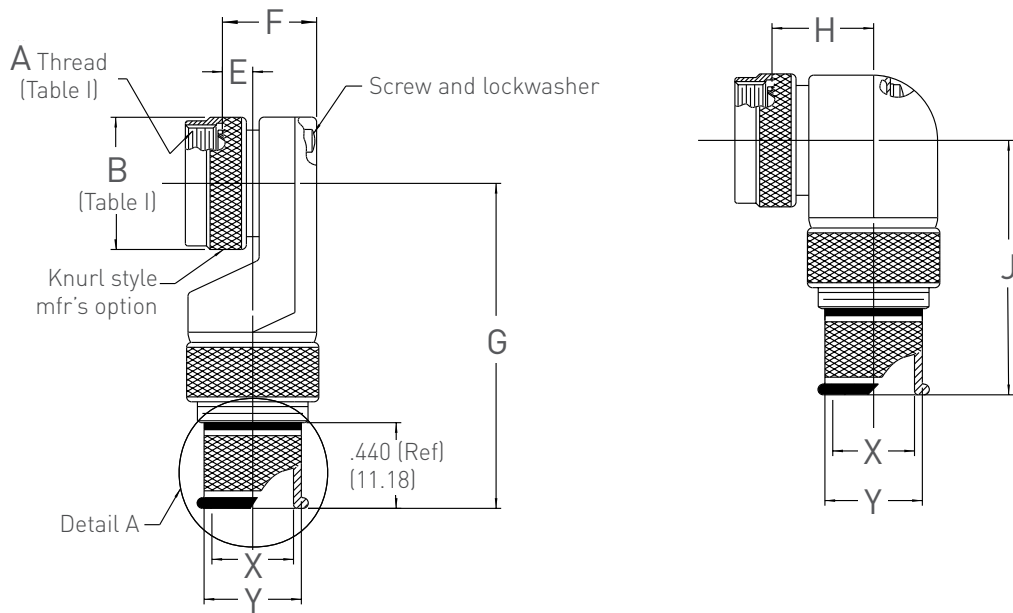

Example part number

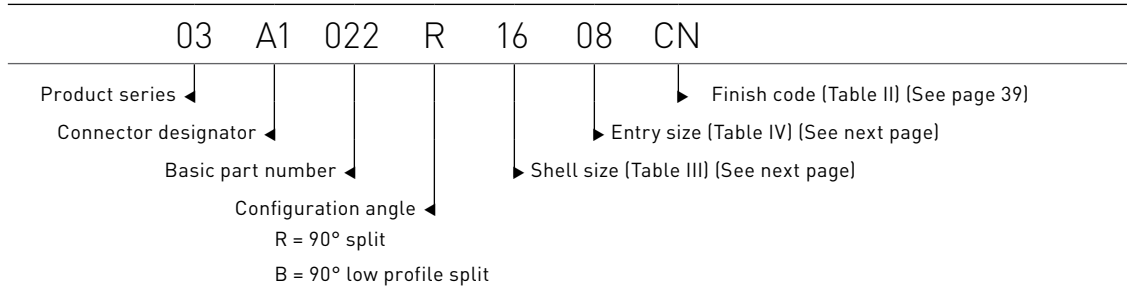

Table III

**Connector designator													
Shell size		E		F		G		H		J		Maximum entry size availability	
A1, F3, L1, X1	F4	max dimension		max dimension		max dimension		max dimension		max dimension		style B	style R
08	09	0.496	(12.6)	0.837	(21.3)	1.870	(47.5)	0.772	(19.6)	1.530	(38.9)	04	04
10	11	0.426	(10.8)	0.887	(22.5)	2.030	(51.6)	0.834	(21.2)	1.590	(40.4)	06	06
12	13	0.426	(10.8)	0.887	(22.5)	2.030	(51.6)	0.897	(22.8)	1.660	(42.2)	06	08
14	15	0.436	(11.1)	0.987	(25.1)	2.100	(53.3)	0.960	(24.4)	1.690	(42.9)	08	10
16	17	0.576	(14.6)	1.137	(28.9)	2.150	(54.6)	1.022	(26.0)	1.790	(45.5)	10	12
18	19	0.796	(20.2)	1.337	(34.0)	2.180	(55.4)	1.084	(27.5)	1.850	(47.0)	10	14
20	21	0.796	(20.2)	1.337	(34.0)	2.180	(55.4)	1.147	(29.1)	1.910	(48.5)	10	16
22	23	0.696	(17.7)	1.337	(34.0)	2.330	(59.2)	1.210	(30.7)	1.970	(50.0)	12	18
24	25	0.696	(17.7)	1.337	(34.0)	2.330	(59.2)	1.272	(32.3)	2.030	(51.6)	12	20

* For connector family identification details see Page 17, Section I. Consult factory for availability of other connector designators not shown above.

Table IV

Entry size	X diameter		Y diameter	
02	0.125	(3.2)	0.245	(6.2)
03	0.188	(4.8)	0.308	(7.8)
04	0.250	(6.4)	0.370	(9.4)
05	0.312	(7.9)	0.432	(11.0)
06	0.375	(9.5)	0.495	(12.6)
07	0.438	(11.1)	0.558	(14.2)
08	0.500	(12.7)	0.620	(15.7)
09	0.562	(14.3)	0.682	(17.3)
10	0.625	(15.9)	0.745	(18.9)
11	0.688	(17.5)	0.808	(20.5)
12	0.750	(19.1)	0.870	(22.1)
13	0.812	(20.6)	0.932	(23.7)
14	0.875	(22.2)	0.995	(25.3)
15	0.938	(23.8)	1.058	(26.9)
16	1.000	(25.4)	1.120	(28.4)
17	1.062	(27.0)	1.182	(30.0)
18	1.125	(28.6)	1.245	(31.6)
20	1.250	(31.8)	1.370	(34.8)

Notes

- 1 Metric dimensions are shown in parentheses for reference only.
- 2 When maximum cable entry is exceeded, style 2 will be supplied.
- 3 See section 90 and 99 (pages 162 and 169) for band termination selection and application tool data

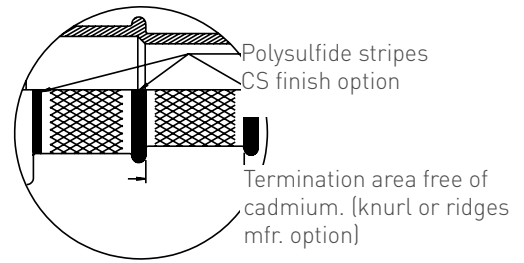
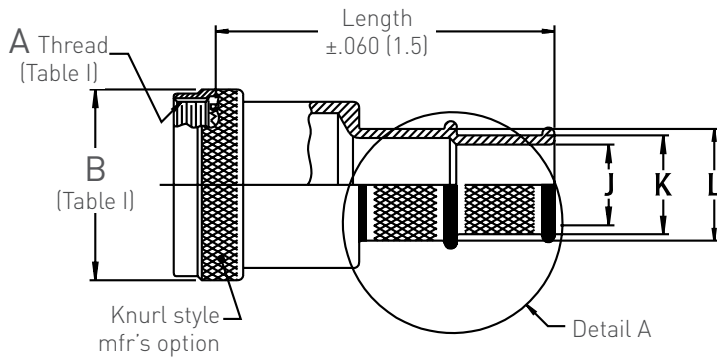

Detail A

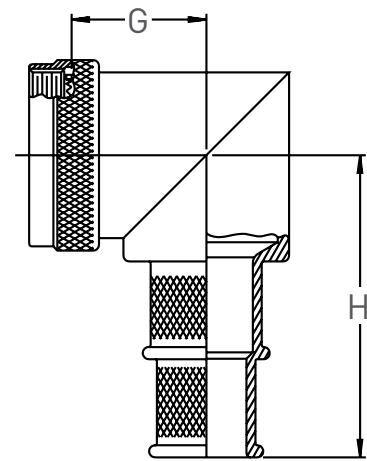
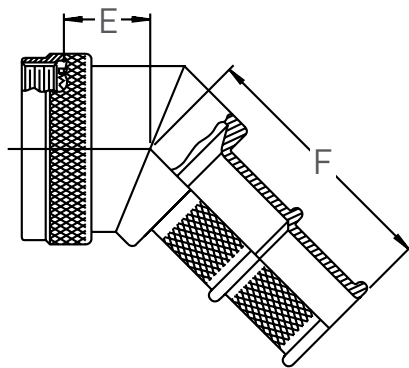

Example part number

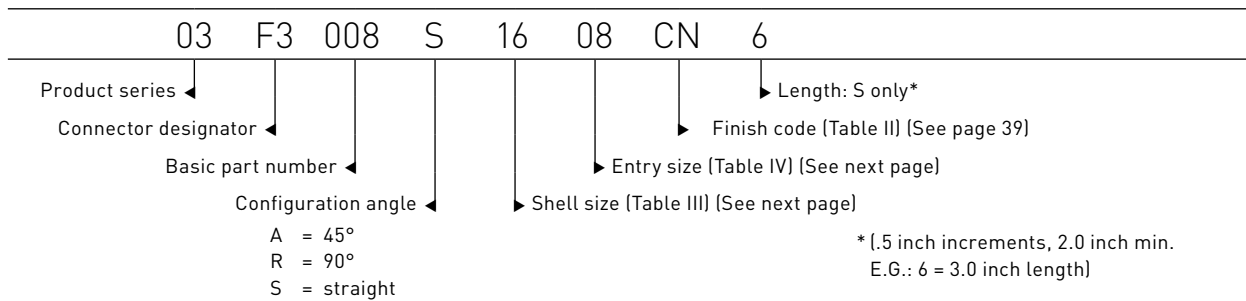

Table III

**Connector designator									
Shell size		E		F		G		H	
A1, F3, L1, X1	F4	max dimension		max dimension		max dimension		max dimension	
08	09	0.546	(13.9)	1.487	(37.8)	0.661	(16.8)	1.624	(41.2)
10	11	0.609	(15.5)	1.515	(38.5)	0.765	(19.4)	1.680	(42.7)
12	13	0.632	(16.1)	1.538	(39.1)	0.820	(20.8)	1.736	(44.1)
14	15	0.657	(16.7)	1.563	(39.7)	0.880	(22.4)	1.802	(45.8)
16	17	0.682	(17.3)	1.588	(40.3)	0.942	(23.9)	1.860	(47.2)
18	19	0.701	(17.8)	1.607	(40.8)	0.986	(25.0)	1.921	(48.8)
20	21	0.727	(18.5)	1.633	(41.5)	1.049	(26.6)	1.991	(50.6)
22	23	0.752	(19.1)	1.658	(42.1)	1.111	(28.2)	2.044	(51.9)
24	25	0.778	(19.8)	1.684	(42.8)	1.174	(29.8)	2.112	(53.6)

* For connector family identification details see Page 17, Section I. Consult factory for availability of other connector designators not shown above.

Table IV

Entry size	J diameter		K diameter		L diameter	
02	0.125	(3.2)	0.221	(5.6)	0.317	(8.1)
04	0.250	(6.4)	0.346	(8.8)	0.442	(11.2)
06	0.375	(9.5)	0.471	(12.0)	0.567	(14.4)
08	0.500	(12.7)	0.596	(15.1)	0.692	(17.6)
10	0.625	(15.9)	0.721	(18.3)	0.817	(20.8)
12	0.750	(19.1)	0.876	(21.5)	0.942	(23.9)
14	0.875	(22.2)	0.971	(24.7)	1.067	(27.1)
16	1.000	(25.4)	1.096	(27.8)	1.192	(30.3)
18	1.125	(28.6)	1.221	(31.0)	1.317	(33.5)
20	1.250	(31.8)	1.346	(34.2)	1.442	(36.6)

Notes

- 1 Metric dimensions are shown in parentheses for reference only.
- 2 Consult factory when cable entry diameter exceeds Z diameter (see page 41).
- 3 See section 90 and 99 (pages 162 and 169) for band termination selection and application tool data

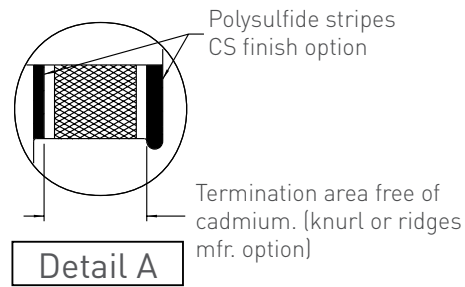
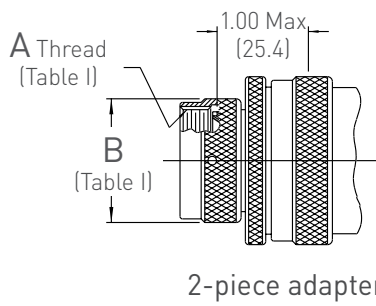
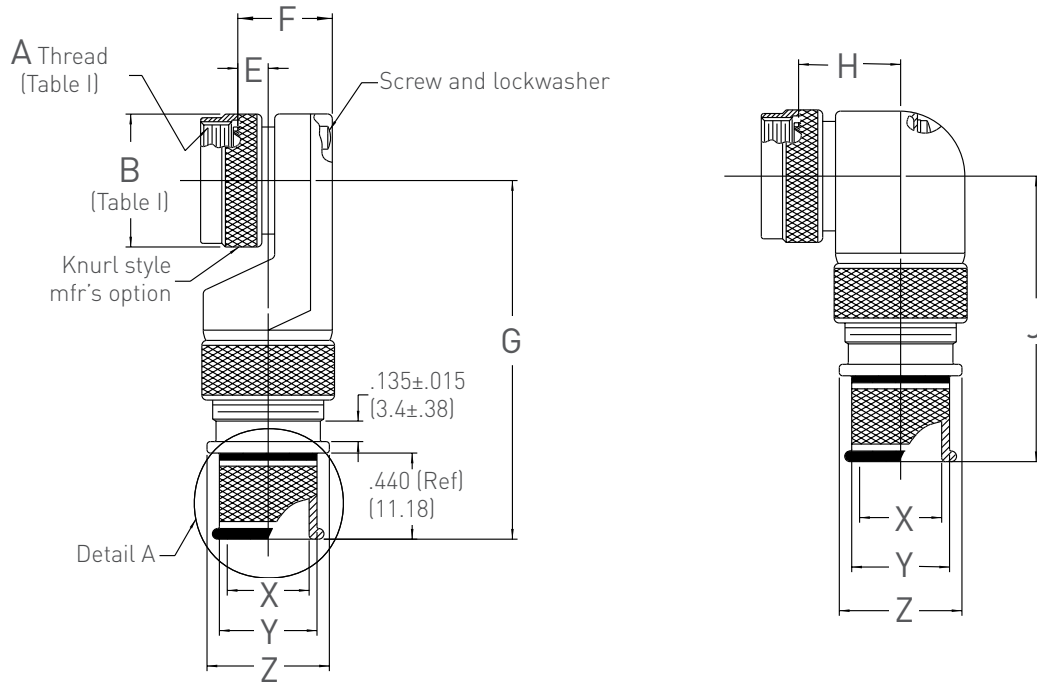

Example part number

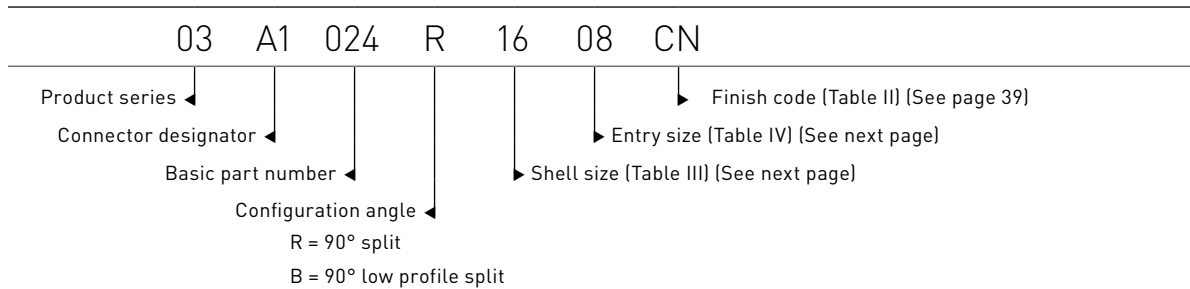

Table III

**Connector designator		E		F		G		H		J		Maximum entry size availability	
Shell size	F4	max dimension		max dimension		max dimension		max dimension		max dimension		style B	style R
A1, F3, L1, X1													
08	09	0.496	(12.6)	0.837	(21.3)	2.220	(56.4)	0.772	(19.6)	1.880	(47.8)	04	04
10	11	0.426	(10.8)	0.887	(22.5)	2.380	(60.5)	0.834	(21.2)	1.940	(49.3)	06	06
12	13	0.426	(10.8)	0.887	(22.5)	2.380	(60.5)	0.897	(22.8)	2.010	(51.1)	06	08
14	15	0.436	(11.1)	0.987	(25.1)	2.450	(62.2)	0.960	(24.4)	2.040	(51.8)	08	10
16	17	0.576	(14.6)	1.137	(28.9)	2.500	(63.5)	1.022	(26.0)	2.140	(54.4)	10	12
18	19	0.796	(20.2)	1.337	(34.0)	2.530	(64.3)	1.084	(27.5)	2.200	(55.9)	10	14
20	21	0.796	(20.2)	1.337	(34.0)	2.530	(64.3)	1.147	(29.1)	2.260	(57.4)	10	16
22	23	0.696	(17.7)	1.337	(34.0)	2.680	(68.1)	1.210	(30.7)	2.320	(58.9)	12	18
24	25	0.696	(17.7)	1.337	(34.0)	2.680	(68.1)	1.272	(32.3)	2.380	(60.5)	12	20

* For connector family identification details see Page 17, Section I. Consult factory for availability of other connector designators not shown above.

Table IV

Entry size	X diameter		Y diameter		Z diameter	
02	0.125	(3.2)	0.245	(6.2)	0.312	(7.9)
03	0.188	(4.8)	0.308	(7.8)	0.375	(9.5)
04	0.250	(6.4)	0.370	(9.4)	0.438	(11.1)
05	0.312	(7.9)	0.432	(11.0)	0.500	(12.7)
06	0.375	(9.5)	0.495	(12.6)	0.562	(14.3)
07	0.438	(11.1)	0.558	(14.2)	0.625	(15.9)
08	0.500	(12.7)	0.620	(15.7)	0.688	(17.5)
09	0.562	(14.3)	0.682	(17.3)	0.750	(19.1)
10	0.625	(15.9)	0.745	(18.9)	0.812	(20.6)
11	0.688	(17.5)	0.808	(20.5)	0.875	(22.2)
12	0.750	(19.1)	0.870	(22.1)	0.938	(23.8)
13	0.812	(20.6)	0.932	(23.7)	1.000	(25.4)
14	0.875	(22.2)	0.995	(25.3)	1.062	(27.0)
15	0.938	(23.8)	1.058	(26.9)	1.125	(28.6)
16	1.000	(25.4)	1.120	(28.4)	1.188	(30.2)
17	1.062	(27.0)	1.182	(30.0)	1.250	(31.8)
18	1.125	(28.6)	1.245	(31.6)	1.312	(33.3)
20	1.250	(31.8)	1.370	(34.8)	1.438	(36.5)

Notes

- 1 Metric dimensions are shown in parentheses for reference only.
- 2 When maximum cable entry is exceeded, style 2 will be supplied.
- 3 See section 90 and 99 (pages 162 and 169) for band termination selection and application tool data

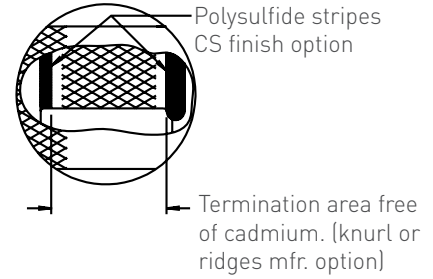
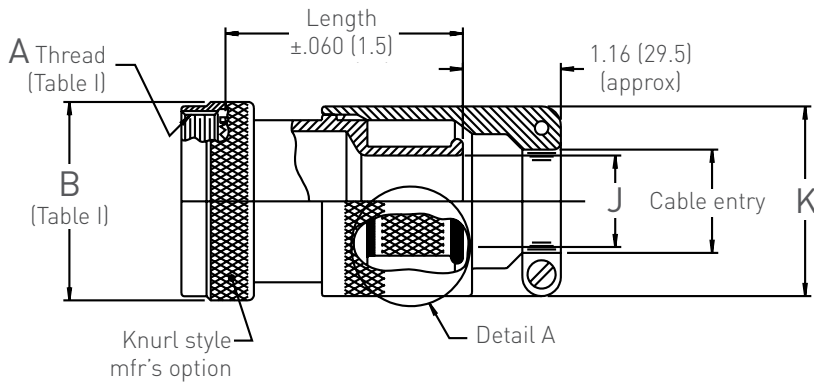

Detail A

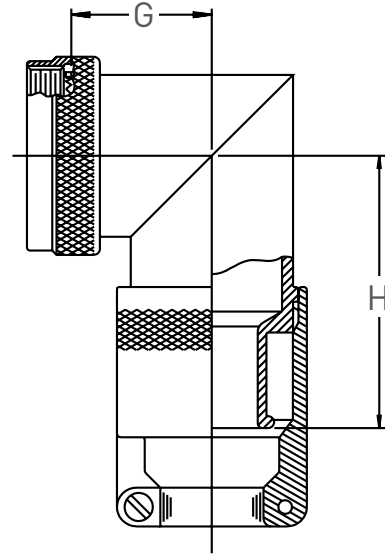
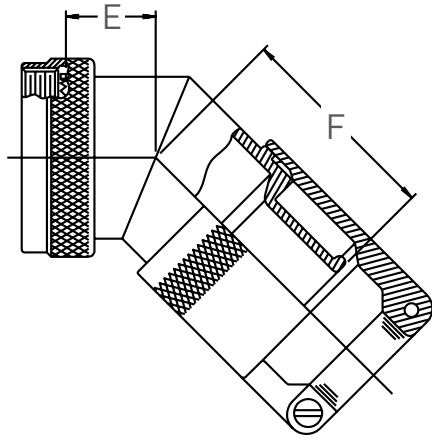

Example part number

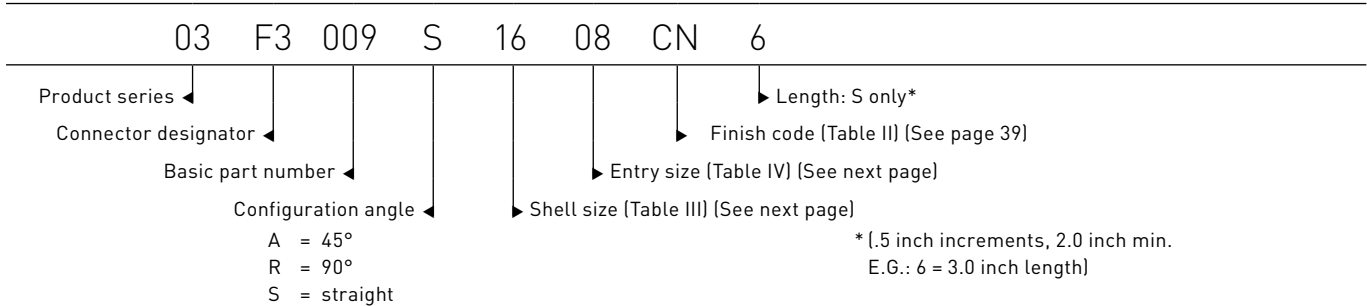

Table III

**Connector designator									
Shell size		E		F		G		H	
A1, F3, L1, X1	F4	max dimension		max dimension		max dimension		max dimension	
08	09	0.546	(13.9)	1.300	(33.0)	0.661	(16.8)	1.499	(38.1)
10	11	0.609	(15.5)	1.328	(33.7)	0.765	(19.4)	1.555	(39.5)
12	13	0.632	(16.1)	1.351	(34.3)	0.820	(20.8)	1.611	(40.9)
14	15	0.657	(16.7)	1.376	(35.0)	0.880	(22.4)	1.677	(42.6)
16	17	0.682	(17.3)	1.401	(35.6)	0.942	(23.9)	1.735	(44.1)
18	19	0.701	(17.8)	1.420	(36.1)	0.986	(25.0)	1.796	(45.6)
20	21	0.727	(18.5)	1.446	(36.7)	1.049	(26.6)	1.866	(47.4)
22	23	0.752	(19.1)	1.471	(37.4)	1.111	(28.2)	1.919	(48.7)
24	25	0.778	(19.8)	1.497	(38.0)	1.174	(29.8)	1.987	(50.5)

* For connector family identification details see Page 17, Section I. Consult factory for availability of other connector designators not shown above.

Table IV

Entry size	J maximum		K maximum		Cable range			
					minimum		maximum	
04	0.219	(5.6)	0.969	(24.6)	0.171	(4.3)	0.250	(6.4)
05	0.312	(7.9)	1.074	(27.3)	0.234	(5.9)	0.344	(8.7)
07	0.438	(11.1)	1.192	(30.3)	0.281	(7.1)	0.469	(11.9)
08	0.500	(12.7)	1.252	(31.8)	0.344	(8.7)	0.531	(13.5)
10	0.625	(15.9)	1.380	(35.1)	0.469	(11.9)	0.656	(16.7)
11	0.688	(17.5)	1.442	(36.6)	0.531	(13.5)	0.718	(18.2)
12	0.750	(19.1)	1.505	(38.2)	0.562	(14.3)	0.781	(19.8)
14	0.875	(22.2)	1.630	(41.4)	0.594	(15.1)	0.906	(23.0)
16	1.000	(25.4)	1.755	(44.6)	0.656	(16.7)	1.031	(26.2)
18	1.188	(30.2)	1.934	(49.1)	0.781	(19.8)	1.218	(30.9)

Notes

- 1 Metric dimensions are shown in parentheses for reference only.
- 2 Cable range is defined as the envelope area of the cable or wire bundle. It is not intended for inspection criteria.
- 3 Consult factory when cable entry diameter exceeds Z diameter (see page 41).
- 4 See Section 90 and 99 (See pages 162 and 169) for band termination selection and application tool data..

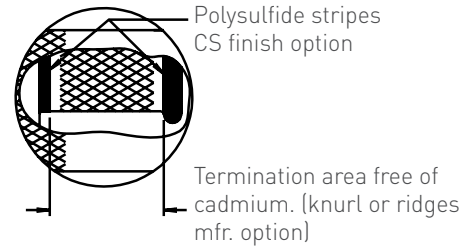
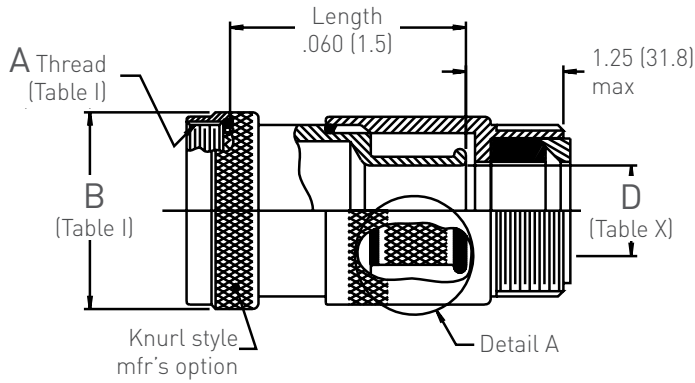

Detail A

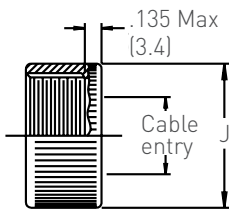
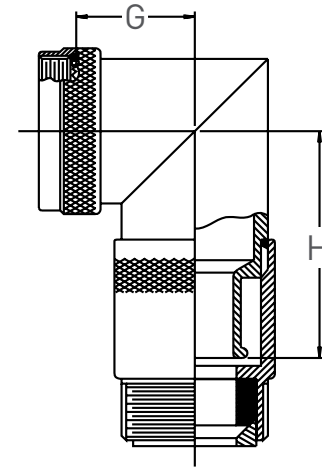
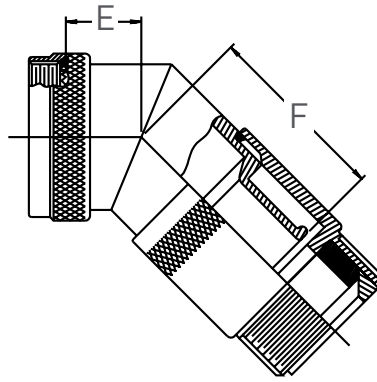

Style C
(Table IV)

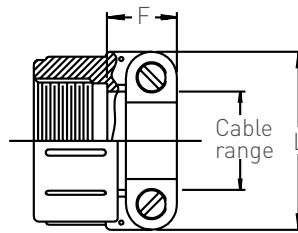

Style A
(Table IV)

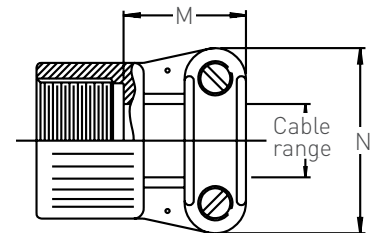

Style F
(Table IV)

Example part number

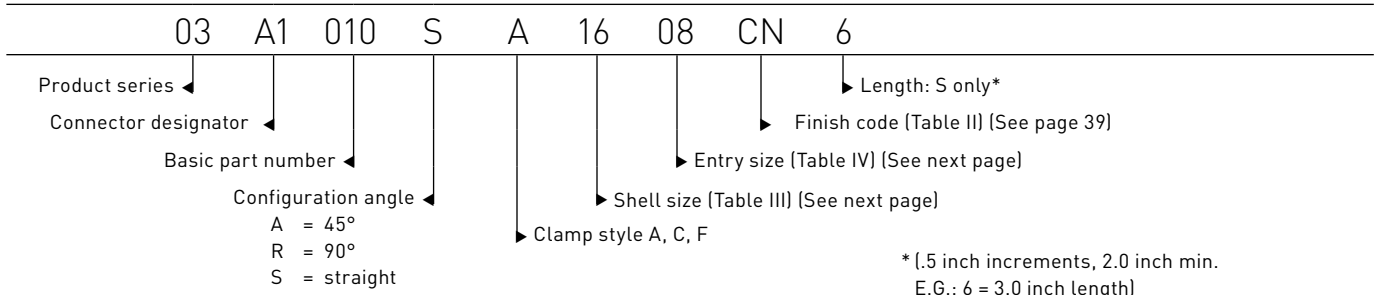

Table III

**Connector designator									
Shell size		E		F		G		H	
A1, F2, L1, X2	F5	max dimension		max dimension		max dimension		max dimension	
08	09	0.612	(15.5)	1.300	(33.0)	0.727	(18.5)	1.499	(38.1)
10	11	0.675	(17.1)	1.328	(33.7)	0.831	(21.1)	1.555	(39.5)
12	13	0.698	(17.7)	1.351	(34.3)	0.886	(22.5)	1.611	(40.9)
14	15	0.723	(18.4)	1.376	(35.0)	0.946	(24.0)	1.677	(42.6)
16	17	0.748	(19.0)	1.401	(35.6)	1.008	(25.6)	1.735	(44.1)
18	19	0.767	(19.5)	1.420	(36.1)	1.052	(26.7)	1.796	(45.6)
20	21	0.793	(20.1)	1.446	(36.7)	1.115	(28.3)	1.866	(47.4)
22	23	0.818	(20.8)	1.471	(37.4)	1.177	(29.9)	1.919	(48.7)
24	25	0.844	(21.4)	1.497	(38.0)	1.240	(31.5)	1.987	(50.5)

* For connector family identification details see Page 17, Section I. Consult factory for availability of other connector designators not shown above.

Table X

Entry size	Clamp size	P dia	
04	03	0.219	(5.6)
05	04	0.312	(7.9)
07	06	0.438	(11.1)
08	08	0.500	(12.7)
10	10	0.625	(15.9)
11	12	0.688	(17.5)
12	12	0.750	(19.1)
14	16	0.875	(22.2)
16	20	1.000	(25.4)
18	20	1.188	(30.2)

Table IV

Clamp size	J max		K max		L max		M max		N max		Cable range			
	min	max	min	max	min	max	min	max	min	max	min	max		
03	0.656	(16.7)	0.453	(11.5)	0.843	(21.4)	N/A		N/A		0.156	(4.0)	0.250	(6.4)
04	0.781	(19.8)	0.453	(11.5)	0.906	(23.0)	0.780	(19.8)	0.957	(24.3)	0.187	(4.7)	0.312	(7.9)
06	0.906	(23.0)	0.516	(13.1)	1.093	(27.8)	0.780	(19.8)	1.145	(29.1)	0.281	(7.1)	0.438	(11.1)
08	1.031	(26.2)	0.579	(14.7)	1.187	(30.1)	0.780	(19.8)	1.332	(33.8)	0.344	(8.7)	0.562	(14.3)
10	1.156	(29.4)	0.579	(14.7)	1.281	(32.5)	0.780	(19.8)	1.332	(33.8)	0.375	(9.5)	0.625	(15.9)
12	1.344	(34.1)	0.579	(14.7)	1.500	(38.1)	0.811	(20.6)	1.551	(39.4)	0.438	(11.1)	0.750	(19.1)
16	1.594	(40.5)	0.672	(17.1)	1.719	(43.7)	0.905	(23.0)	1.770	(45.0)	0.562	(14.3)	0.938	(23.8)
20	1.906	(48.4)	0.672	(17.1)	2.062	(52.4)	1.092	(27.7)	2.113	(53.7)	0.750	(19.1)	1.250	(31.8)

Notes

- 1 Metric dimensions are shown in parentheses for reference only.
- 2 Cable range is defined as the envelope area of the cable or wire bundle. It is not intended for inspection criteria.
- 3 O-ring not supplied on connector designators A1 and L1. F2 is moisture proof only.
- 4 Consult factory when cable entry diameter exceeds Z diameter (see page 41).
- 5 See Section 90 and 99 (See pages 162 and 169) for band termination selection and application tool data..

Tolerance

Unless otherwise specified:

- .X ± .060 (1.5)
- .XX ± .030 (0.8)
- .XXX ± .015 (0.4)
- Angles ± 5 degrees

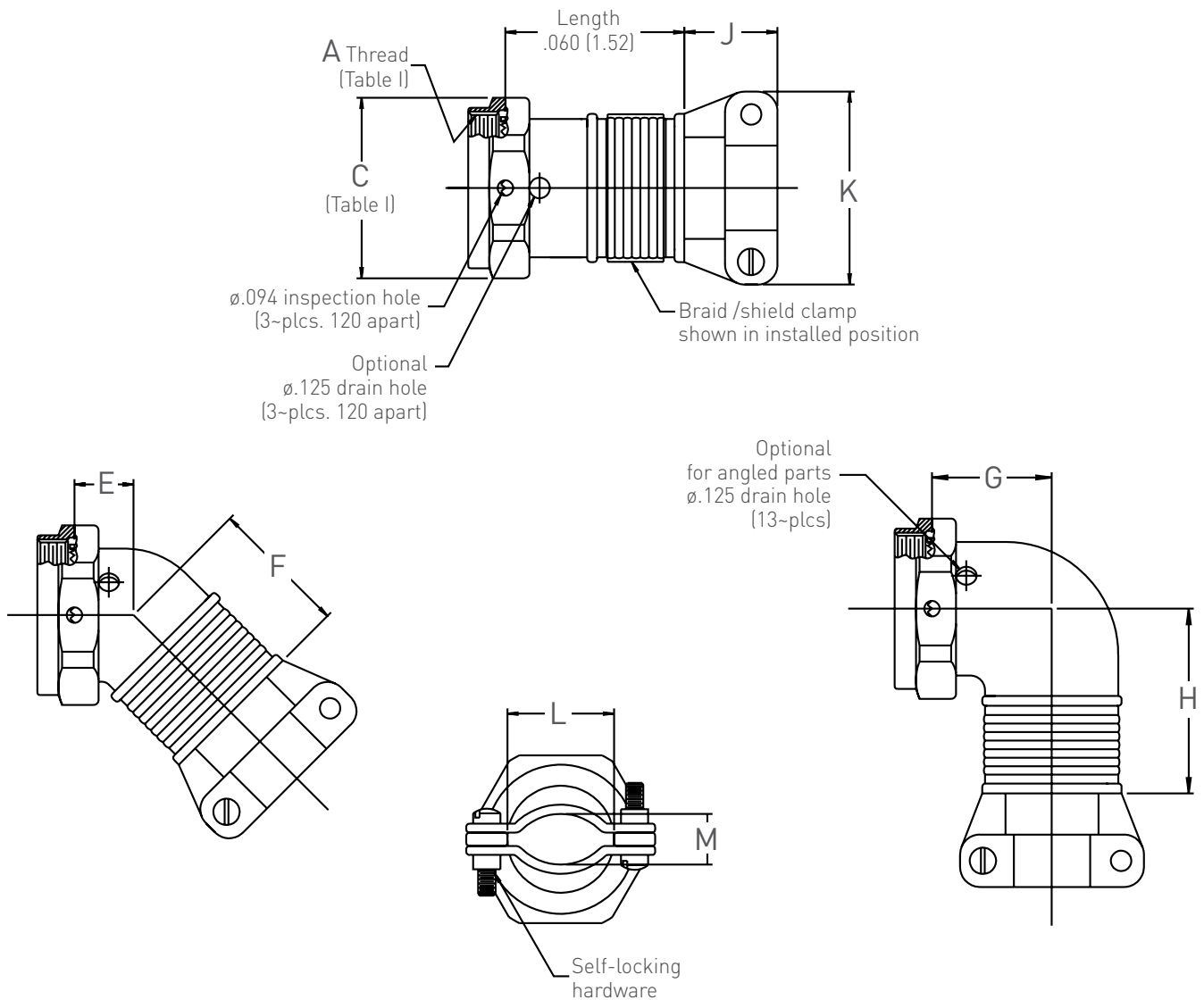

Example part number

03	F4	011	S	15	1	P	6	D
Product series	Connector designator	Basic part number	Configuration angle	Shell size (Table III) (See next page)	Entry size (Table IV) (See next page)	Finish code*** (Table II) (See page 39)	Length: S only**	Drain hole option*
			A = 45° R = 90° S = straight					

* Omit for none
 ** (.5 inch increments, 1.5 inch min. E.G.: 6 = 3.0 inch length)
 *** (Available Finish Codes P, PN and PC Only)

Table III

**Connector designator													
Shell size		E		F		G		H		J		K	
A1, F3, L1, X1	F4	max dimension		max dimension		max dimension		max dimension		max dimension		max dimension	
08	09	0.590	(15.0)	1.000	(25.4)	0.730	(18.5)	1.220	(31.0)	0.750	(19.1)	1.000	(25.4)
10	11	0.610	(15.5)	1.030	(26.2)	0.780	(19.8)	1.250	(31.8)	0.750	(19.1)	1.094	(27.8)
12	13	0.680	(17.3)	1.090	(27.7)	0.880	(22.4)	1.280	(32.5)	0.750	(19.1)	1.281	(32.5)
14	15	0.680	(17.3)	1.090	(27.7)	0.880	(22.4)	1.280	(32.5)	0.750	(19.1)	1.281	(32.5)
16	17	0.760	(19.3)	1.420	(36.1)	0.940	(23.9)	1.420	(36.1)	0.750	(19.1)	1.438	(36.5)
18	19	0.760	(19.3)	1.420	(36.1)	0.940	(23.9)	1.420	(36.1)	0.750	(19.1)	1.438	(36.5)
20	21	0.950	(24.1)	1.600	(40.6)	1.040	(26.4)	1.580	(40.1)	0.880	(22.4)	1.750	(44.5)
22	23	1.050	(26.7)	1.750	(44.5)	1.250	(31.8)	1.680	(42.7)	0.880	(22.4)	2.062	(52.4)
24	25	1.050	(26.7)	1.750	(44.5)	1.250	(31.8)	1.680	(42.7)	0.880	(22.4)	2.062	(52.4)
28		1.170	(29.7)	1.810	(46.0)	1.530	(38.9)	1.850	(47.0)	0.880	(22.4)	2.188	(55.6)

* For connector family identification details see Page 17, Section I. Consult factory for availability of other connector designators not shown above.

Table IV

**Connector designator											
Shell size		Clamp size		Entry style 1				Entry style 2			
A1, F3, L1, X1	F4	(ref) 90-006-		L		M		L		M	
08	09	11		0.420	(10.7)	0.330	(8.4)	0.420	(10.7)	0.255	(6.5)
10	11	11		0.531	(13.5)	0.438	(11.1)	0.531	(13.5)	0.255	(6.5)
12	13	32		0.718	(18.2)	0.562	(14.3)	0.718	(18.2)	0.340	(8.6)
14	15	32		0.718	(18.2)	0.562	(14.3)	0.718	(18.2)	0.340	(8.6)
16	17	14		0.850	(21.6)	0.718	(18.2)	0.850	(21.6)	0.455	(11.6)
18	19	14		0.850	(21.6)	0.718	(18.2)	0.850	(21.6)	0.455	(11.6)
20	21	15		1.031	(26.2)	0.900	(22.9)	1.031	(26.2)	0.600	(15.2)
22	23	15		1.350	(34.3)	1.156	(29.4)	1.350	(34.3)	0.790	(20.1)
24	25	16		1.350	(34.3)	1.156	(29.4)	1.350	(34.3)	0.790	(20.1)
28		17		1.475	(37.5)	1.351	(34.3)	1.475	(37.5)	0.880	(22.4)

Notes

- 1 Metric dimensions are shown in parentheses for reference only.
- 2 Assembly supplied with shield termination clamp.

Tolerance

- Unless otherwise specified:
- .X ± .060 (1.5)
- .XX ± .030 (0.8)
- .XXX ± .015 (0.4)
- Angles ± 5 degrees

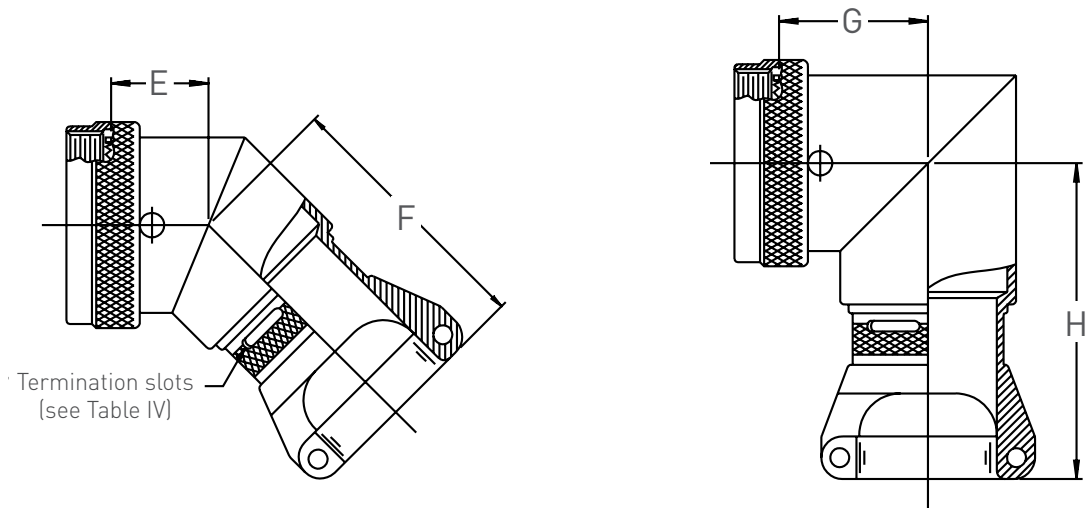
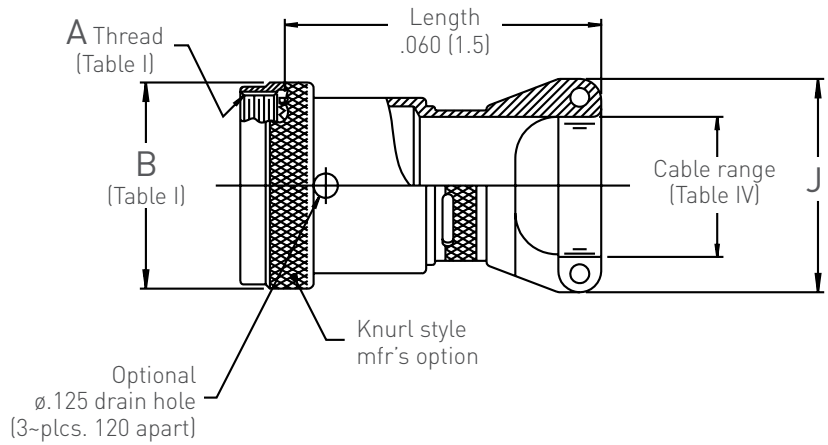

Example part number

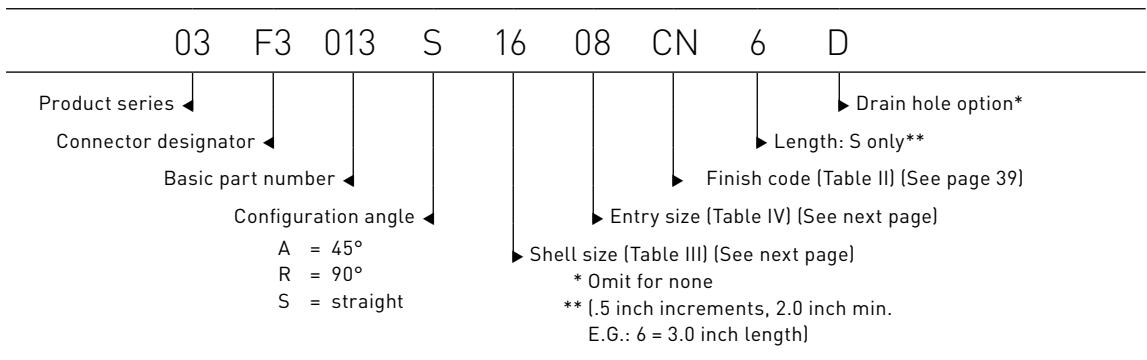

Table III

**Connector designator									
Shell size		E		F		G		H	
A1, F3, L1, X1	F4	max dimension		max dimension		max dimension		max dimension	
08	09	0.577	(14.7)	1.362	(34.6)	0.692	(17.6)	1.624	(41.2)
10	11	0.640	(16.3)	1.390	(35.3)	0.796	(20.2)	1.680	(42.7)
12	13	0.673	(17.1)	1.413	(35.9)	0.851	(21.6)	1.736	(44.1)
14	15	0.688	(17.5)	1.438	(36.5)	0.911	(23.1)	1.802	(45.8)
16	17	0.713	(18.1)	1.463	(37.2)	0.973	(24.7)	1.860	(47.2)
18	19	0.732	(18.6)	1.482	(37.6)	1.017	(25.8)	1.921	(48.8)
20	21	0.758	(19.3)	1.570	(39.9)	1.080	(27.4)	2.053	(52.1)
22	23	0.783	(19.9)	1.595	(40.5)	1.142	(29.0)	2.106	(53.5)
24	25	0.809	(20.5)	1.621	(41.2)	1.205	(30.6)	2.174	(55.2)

* For connector family identification details see Page 17, Section I. Consult factory for availability of other connector designators not shown above.

Table IV

Entry size	J max		Cable range				No of
			min	max			
04	0.842	(21.4)	0.094	(2.4)	0.219	(5.6)	2
05	0.968	(24.6)	0.188	(4.8)	0.312	(7.9)	2
07	1.092	(27.7)	0.312	(7.9)	0.438	(11.1)	2
08	1.208	(30.7)	0.375	(9.5)	0.500	(12.7)	2
10	1.208	(30.7)	0.438	(11.1)	0.625	(15.9)	2
11	1.208	(30.7)	0.500	(12.7)	0.688	(17.5)	2
13	1.334	(33.9)	0.625	(15.9)	0.812	(20.6)	3
14	1.459	(37.1)	0.688	(17.5)	0.875	(22.2)	3
16	1.584	(40.2)	0.812	(20.6)	1.000	(25.4)	3
19	1.708	(43.4)	1.000	(25.4)	1.188	(30.2)	3

Notes

1. Metric dimensions are shown in parentheses for reference only.
2. Cable range is defined as the envelope area of the cable or wire bundle. It is not intended for inspection criteria.
3. Consult factory when cable entry diameter exceeds Z diameter (see page 41).
4. See Section 90 and 99 (See pages 162 and 169) for band termination selection and application tool data..

Tolerance

- Unless otherwise specified:
- .X ± .060 (1.5)
 - .XX ± .030 (0.8)
 - .XXX ± .015 (0.4)
 - Angles ± 5 degrees

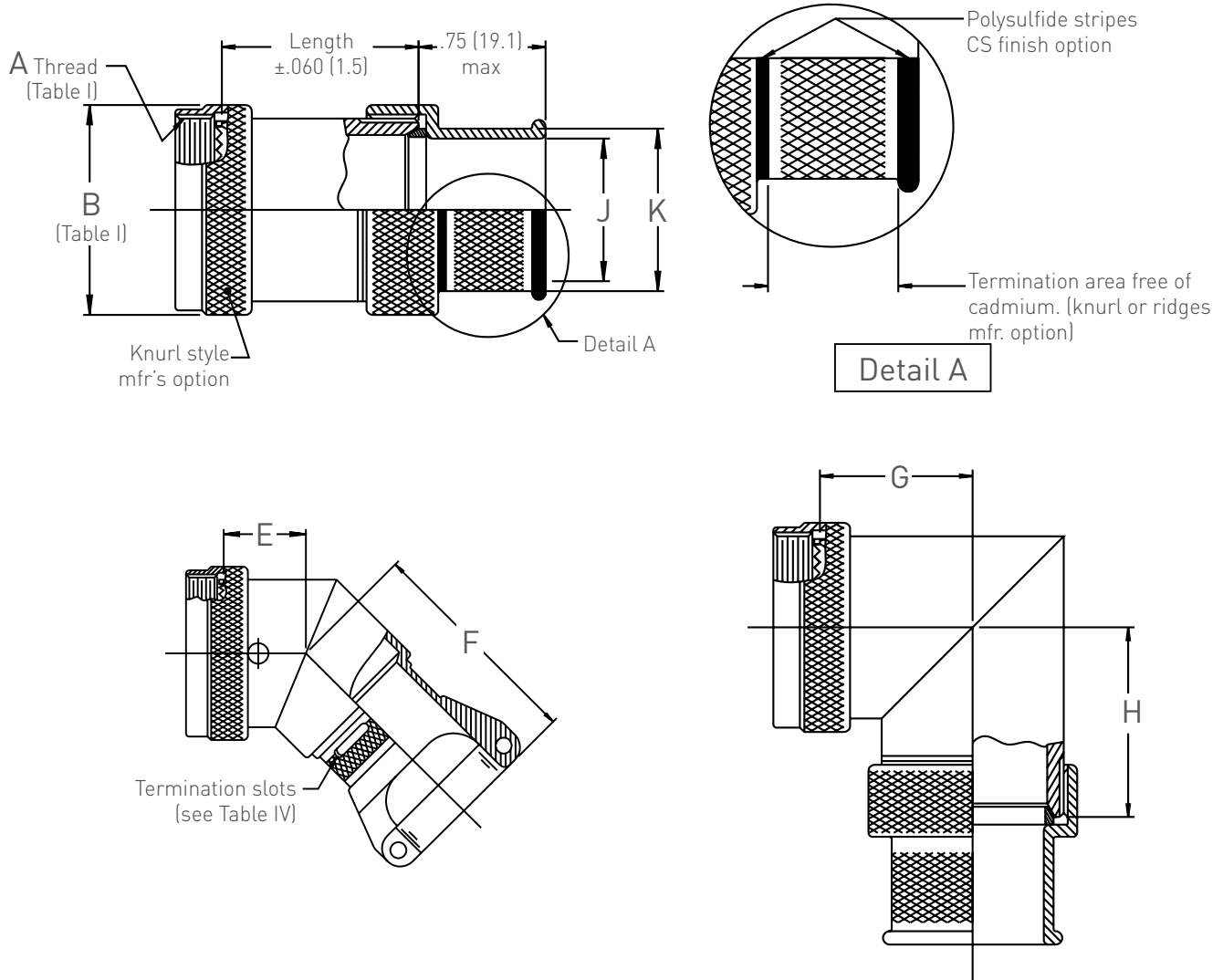

Example part number

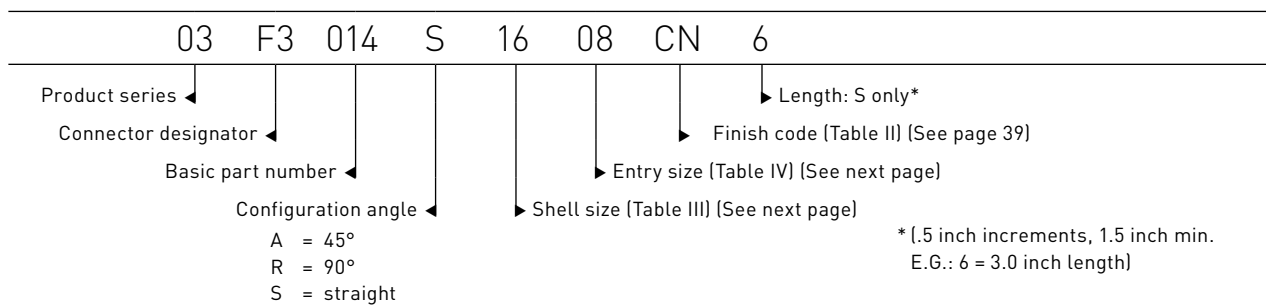

Table III

**Connector designator									
Shell size		E		F		G		H	
A1, F3, L1, X1	F4	max dimension		max dimension		max dimension		max dimension	
08	09	0.546	(13.9)	1.300	(33.0)	0.661	(16.8)	1.499	(38.1)
10	11	0.609	(15.5)	1.328	(33.7)	0.765	(19.4)	1.561	(39.6)
12	13	0.632	(16.1)	1.351	(34.3)	0.820	(20.8)	1.619	(41.1)
14	15	0.657	(16.7)	1.376	(35.0)	0.880	(22.4)	1.677	(42.6)
16	17	0.682	(17.3)	1.401	(35.6)	0.942	(23.9)	1.735	(44.1)
18	19	0.701	(17.8)	1.420	(36.1)	0.986	(25.0)	1.796	(45.6)
20	21	0.727	(18.5)	1.446	(36.7)	1.049	(26.6)	1.866	(47.4)
22	23	0.752	(19.1)	1.471	(37.4)	1.111	(28.2)	1.919	(48.7)
24	25	0.778	(19.8)	1.497	(38.0)	1.174	(29.8)	1.987	(50.5)

* For connector family identification details see Page 17, Section I. Consult factory for availability of other connector designators not shown above.

Table IV

Entry size	J diameter		K diameter	
02	0.125	(3.2)	0.221	(5.6)
04	0.250	(6.4)	0.346	(8.8)
06	0.375	(9.5)	0.471	(12.0)
08	0.500	(12.7)	0.596	(15.1)
10	0.625	(15.9)	0.721	(18.3)
12	0.750	(19.1)	0.846	(21.5)
14	0.875	(22.2)	0.971	(24.7)
16	1.000	(25.4)	1.096	(27.8)
18	1.125	(28.6)	1.221	(31.0)
20	1.250	(31.8)	1.346	(34.2)

Notes

- 1 Metric dimensions are shown in parentheses for reference only.
- 2 Consult factory when cable entry diameter exceeds Z diameter (see page 41).
- 3 See Section 90 and 99 (See pages 162 and 169) for band termination selection and application tool data..

Tolerance

Unless otherwise specified:
 .X ± .060 (1.5)
 .XX ± .030 (0.8)
 .XXX ± .015 (0.4)
 Angles ± 5 degrees

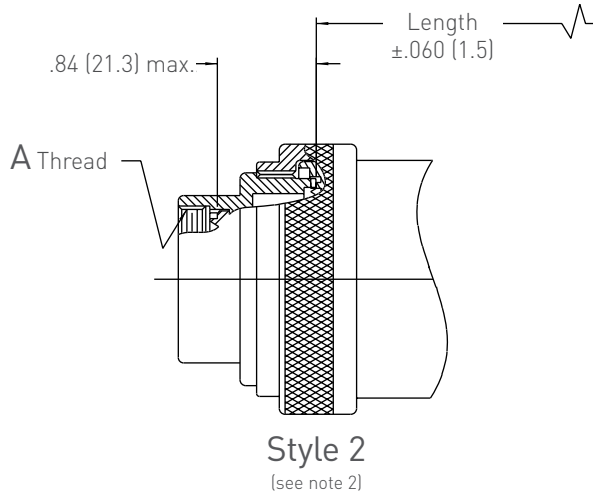
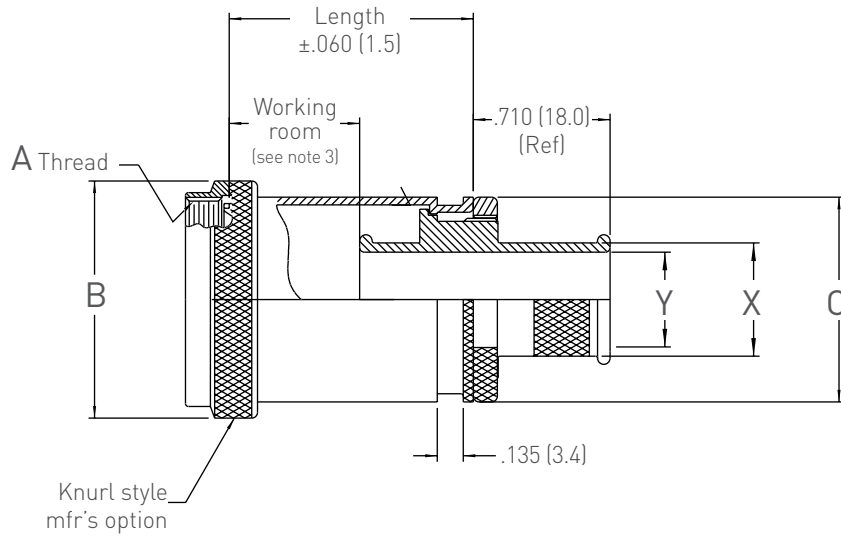

Example part number

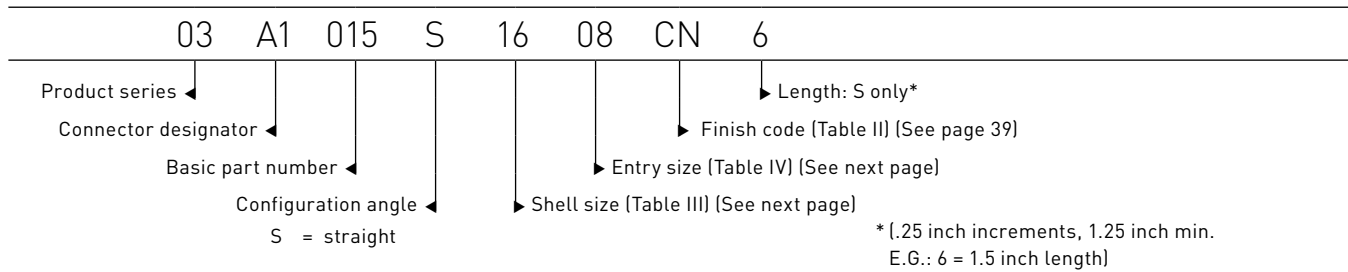

Table III

**Connector designator		E ref diameter						Cable entry max		
Shell size		F2		F5 & X2		A1 & L1		F2	F5 & X2	
A1, F2, L1, X2	F5, A1, & L1									
08	09	N/A		N/A		N/A		N/A	N/A	N/A
10	11	0.500	(12.7)	0.500	(12.7)	0.562	(14.3)	04	04	04
12	13	0.625	(15.9)	0.625	(15.9)	0.688	(17.5)	05	05	06
14	15	0.688	(17.5)	0.750	(19.1)	0.750	(19.1)	06	08	08
16	17	0.812	(20.6)	0.875	(22.2)	0.938	(23.8)	08	09	10
18	19	0.875	(22.2)	0.938	(23.8)	1.000	(25.4)	09	10	11
20	21	1.000	(25.4)	1.062	(27.0)	1.125	(28.6)	11	12	13
22	23	1.125	(28.6)	1.250	(31.8)	1.250	(31.8)	13	15	15
24	25	1.250	(31.8)	1.312	(33.3)	1.312	(33.3)	15	16	16

* For connector family identification details see Page 17, Section I. Consult factory for availability of other connector designators not shown above.

Table IV

Entry size	X ref diameter		Y ± .010 diameter	
03	0.246	(6.2)	0.156	(4.0)
04	0.306	(7.8)	0.216	(5.5)
05	0.385	(9.8)	0.295	(7.5)
06	0.485	(11.8)	0.375	(9.5)
07	0.503	(12.8)	0.413	(10.5)
08	0.582	(14.8)	0.492	(12.5)
09	0.641	(16.3)	0.551	(14.0)
10	0.700	(17.8)	0.610	(15.5)
11	0.759	(19.3)	0.669	(17.0)
12	0.818	(20.8)	0.728	(18.5)
13	0.877	(22.3)	0.787	(20.0)
14	0.936	(23.8)	0.846	(21.5)
15	0.995	(25.3)	0.905	(23.5)
16	1.074	(27.3)	0.984	(25.0)

Notes

- 1 Metric dimensions are shown in parentheses for reference only.
- 2 When maximum cable entry is exceeded, style 2 will be supplied.
- 3 Working room length is approximately .600 less than order length.
- 4 See Section 90 and 99 (See pages 162 and 169) for band termination selection and application tool data..

Tolerance

Unless otherwise specified:

- .X ± .060 (1.5)
- .XX ± .030 (0.8)
- .XXX ± .015 (0.4)
- Angles ± 5 degrees

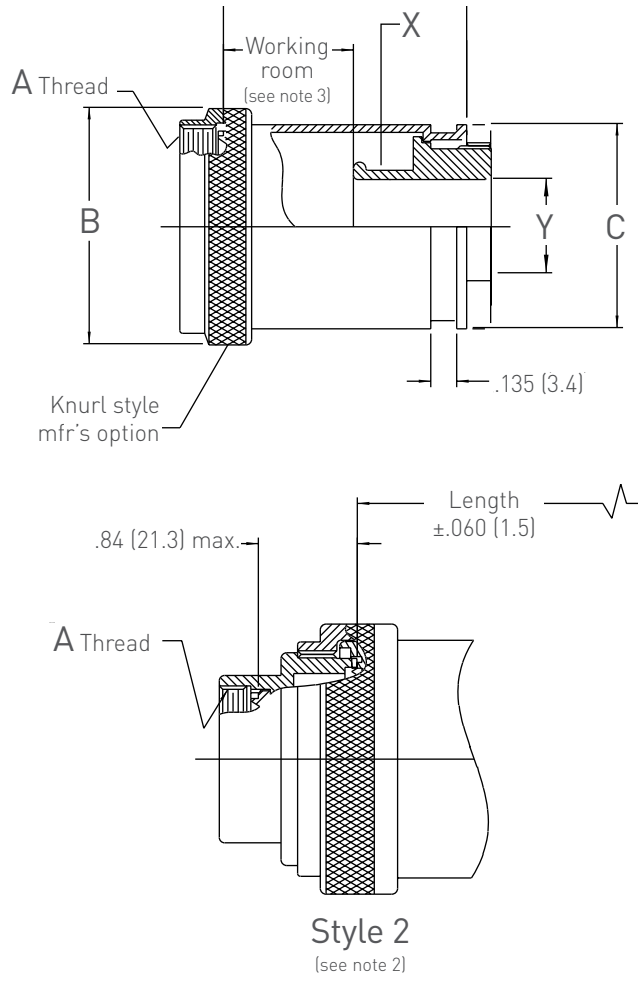

Example part number

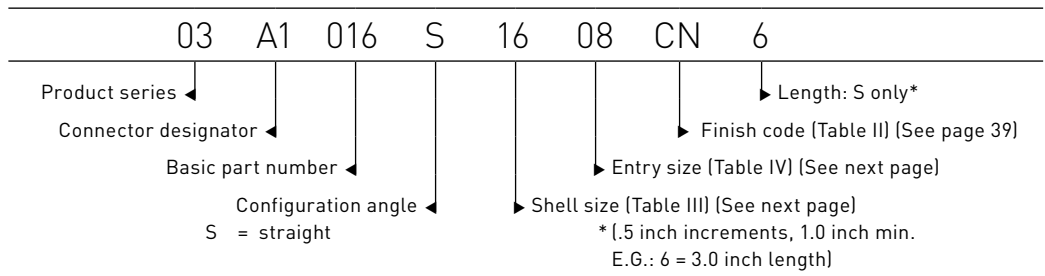

Table III

**Connector designator		E ref. diameter						Cable entry max.		
Shell size										
A1, F2, L1, X2	F5 A1 & L1	F2		F5 & X2		A1 & L1		F2	F5 & X2	
08	09	N/A		N/A		N/A		N/A	N/A	N/A
10	11	0.500	(12.7)	0.500	(12.7)	0.562	(14.3)	04	04	04
12	13	0.625	(15.9)	0.625	(15.9)	0.688	(17.5)	05	05	06
14	15	0.688	(17.5)	0.750	(19.1)	0.750	(19.1)	06	08	08
16	17	0.812	(20.6)	0.875	(22.2)	0.938	(23.8)	08	09	10
18	19	0.875	(22.2)	0.938	(23.8)	1.000	(25.4)	09	10	11
20	21	1.000	(25.4)	1.062	(27.0)	1.125	(28.6)	11	12	13
22	23	1.125	(28.6)	1.250	(31.8)	1.250	(31.8)	13	15	15
24	25	1.250	(31.8)	1.312	(33.3)	1.312	(33.3)	15	16	16

* For connector family identification details see Page 17, Section I. Consult factory for availability of other connector designators not shown above.

Table IV

Entry size	X ref. diameter		Y ± .010 diameter	
03	0.246	(6.2)	0.156	(4.0)
04	0.306	(7.8)	0.216	(5.5)
05	0.385	(9.8)	0.295	(7.5)
06	0.485	(11.8)	0.375	(9.5)
07	0.503	(12.8)	0.413	(10.5)
08	0.582	(14.8)	0.492	(12.5)
09	0.641	(16.3)	0.551	(14.0)
10	0.700	(17.8)	0.610	(15.5)
11	0.759	(19.3)	0.669	(17.0)
12	0.818	(20.8)	0.728	(18.5)
13	0.877	(22.3)	0.787	(20.0)
14	0.936	(23.8)	0.846	(21.5)
15	0.995	(25.3)	0.905	(23.5)
16	1.074	(27.3)	0.984	(25.0)

Notes

- 1 Metric dimensions are shown in parentheses for reference only.
- 2 When maximum cable entry is exceeded, style 2 will be supplied.
- 3 Working room length is approximately .600 less than order length.
- 4 See Section 90 and 99 (See pages 162 and 169) for band termination selection and application tool data..

Tolerance

- Unless otherwise specified:
- .X ± .060 (1.5)
 - .XX ± .030 (0.8)
 - .XXX ± .015 (0.4)
 - Angles ± 5 degrees

Basic part designator	Product page	Configuration description	
001 017	75 77	These products have a circular shape self-seating spin coupling nut and are an economical solution to terminating single or double over-all cable shields or individual cable shields where future repairability and maintainability are required. It provides a full 360 degree shield termination utilizing either Sunbank's banding system or constant force spring termination device.	
008	79	Backshells with a circular shaped self-seating coupling nut that accommodates heat shrinkable boots for environmental sealing capabilities.	
009 026	81 83	Accessories with shrink boot accommodations having a shield sock attached at the rear of the adapter by means of crimp ring, band, constant force spring or magnaforming. The shield sock can then be attached to the overall cable shield by means of a split support ring and then terminated with a band or constant force spring.	

Note: shrink boot reference data is available on page 44

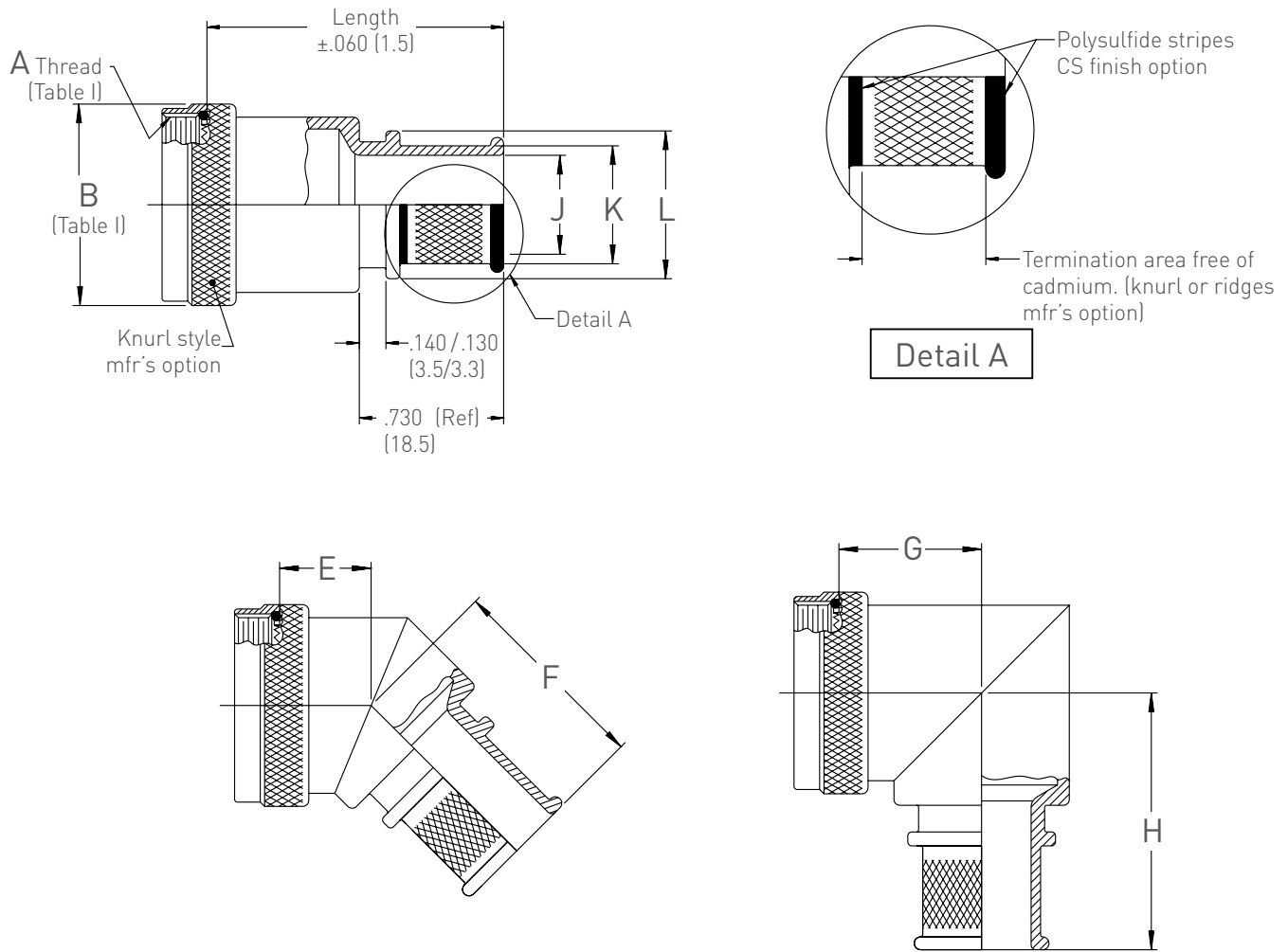

Example part number

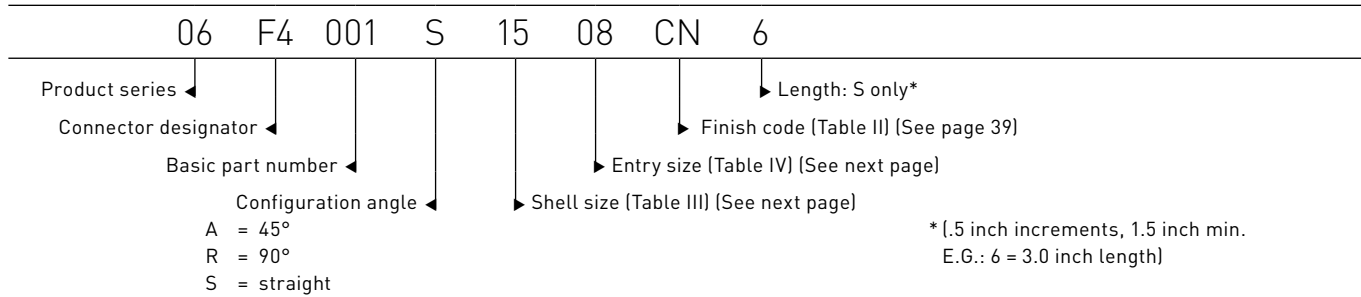

Table III

**Connector designator									
Shell size		E		F		G		H	
A1, F3, L1, X1	F4	max dimension		max dimension		max dimension		max dimension	
08	09	0.612	(15.5)	1.092	(27.7)	0.727	(18.5)	1.275	(32.4)
10	11	0.675	(17.1)	1.119	(28.4)	0.831	(21.1)	1.340	(34.0)
12	13	0.698	(17.7)	1.143	(29.0)	0.886	(22.5)	1.403	(35.6)
14	15	0.723	(18.4)	1.169	(29.7)	0.946	(24.0)	1.465	(37.2)
16	17	0.748	(19.0)	1.195	(30.4)	1.008	(25.6)	1.521	(38.6)
18	19	0.767	(19.5)	1.215	(30.9)	1.052	(26.7)	1.592	(40.4)
20	21	0.793	(20.1)	1.241	(31.5)	1.115	(28.3)	1.648	(41.9)
22	23	0.818	(20.8)	1.266	(32.2)	1.177	(29.9)	1.701	(43.2)
24	25	0.844	(21.4)	1.292	(32.8)	1.240	(31.5)	1.766	(44.9)

* For connector family identification details see Page 17, Section I. Consult factory for availability of other connector designators not shown above.

Table IV

Entry size	J diameter		K diameter		L diameter	
02	0.125	(3.2)	0.221	(5.6)	0.372	(9.4)
04	0.250	(6.4)	0.346	(8.8)	0.497	(12.6)
06	0.375	(9.5)	0.471	(12.0)	0.622	(15.8)
08	0.500	(12.7)	0.596	(15.1)	0.747	(19.0)
10	0.625	(15.9)	0.721	(18.3)	0.872	(22.1)
12	0.750	(19.1)	0.846	(21.5)	0.997	(25.3)
14	0.875	(22.2)	0.971	(24.7)	1.122	(28.5)
16	1.000	(25.4)	1.096	(27.8)	1.247	(31.7)
18	1.125	(28.6)	1.221	(31.0)	1.372	(34.8)
20	1.250	(31.8)	1.346	(34.2)	1.497	(38.0)

Notes

- 1 Metric dimensions are shown in parentheses for reference only.
- 2 O-ring not supplied on connector designators A1 and L1. F2 is moisture proof only.
- 3 See shrink boot reference data, page 44.
- 4 Consult factory when cable entry diameter exceeds Z diameter (see page 41).
- 5 See Section 90 and 99 (See pages 162 and 169) for band termination selection and application tool data.

Tolerance

Unless otherwise specified:

- .X ± .060 (1.5)
- .XX ± .030 (0.8)
- .XXX ± .015 (0.4)
- Angles ± 5 degrees

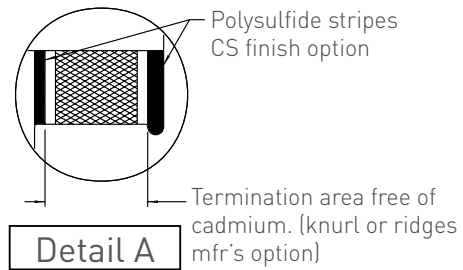
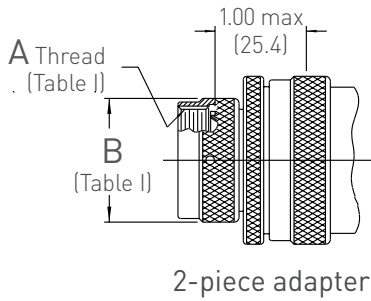
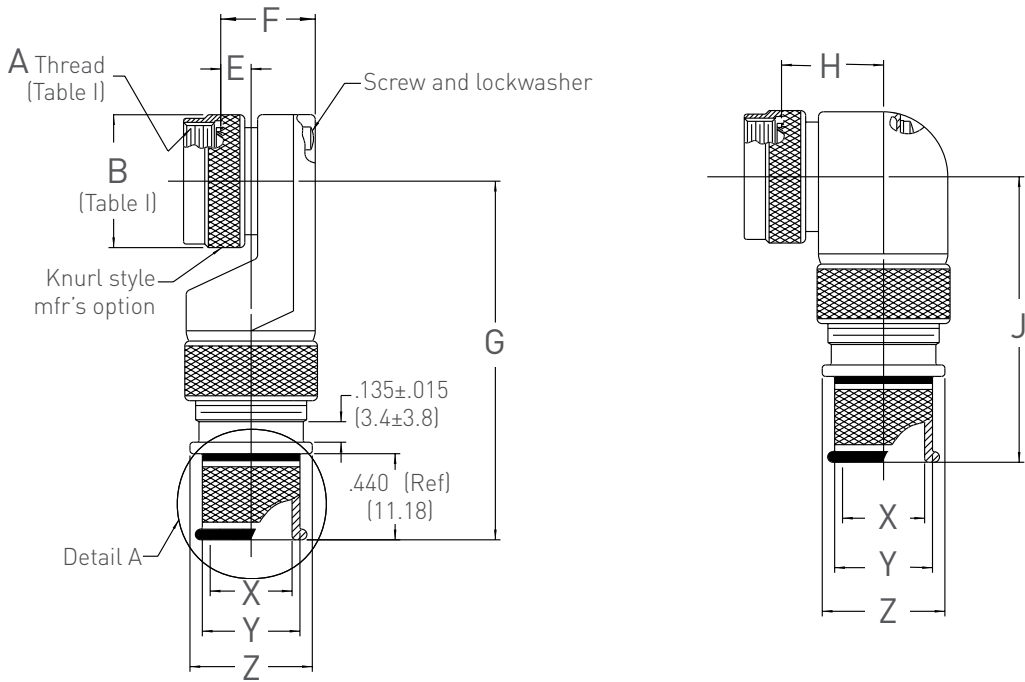

Example part number

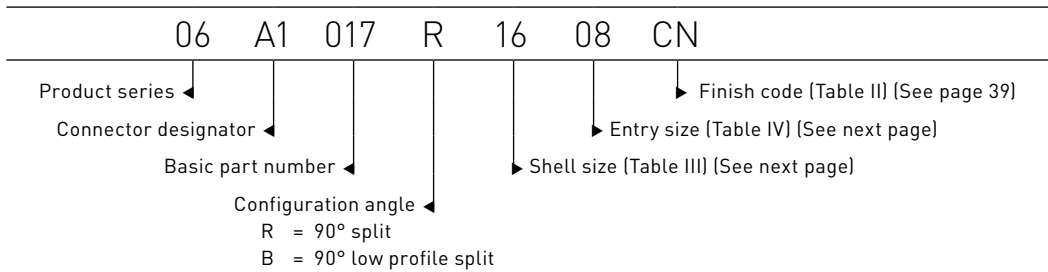

Table III

**Connector designator												Maximum entry size availability	
Shell size		E		F		G		H		J		style B	style R
A1, F3, L1, X1	F4	max dimension		max dimension		max dimension		max dimension		max dimension			
08	09	0.496	(12.5)	0.837	(21.3)	1.915	(48.6)	0.772	(19.6)	1.575	(40.0)	04	04
10	11	0.426	(10.8)	0.887	(22.5)	2.075	(52.7)	0.834	(21.2)	1.635	(41.5)	06	06
12	13	0.426	(10.8)	0.887	(22.5)	2.075	(52.7)	0.897	(22.8)	1.705	(43.3)	06	08
14	15	0.436	(11.1)	0.987	(25.1)	2.145	(54.5)	0.960	(24.4)	1.735	(44.1)	08	10
16	17	0.576	(14.6)	1.137	(28.9)	2.195	(55.8)	1.022	(26.0)	1.835	(46.6)	10	12
18	19	0.796	(20.2)	1.337	(34.0)	2.225	(56.5)	1.084	(27.5)	1.895	(48.1)	10	14
20	21	0.796	(20.2)	1.337	(34.0)	2.225	(56.5)	1.147	(29.1)	1.955	(49.7)	10	16
22	23	0.696	(17.7)	1.337	(34.0)	2.375	(60.3)	1.210	(30.7)	2.015	(51.2)	12	18
24	25	0.696	(17.7)	1.337	(34.0)	2.375	(60.3)	1.272	(32.3)	2.075	(52.7)	12	20

* For connector family identification details see Page 17, Section I. Consult factory for availability of other connector designators not shown above.

Table IV

Entry size	X diameter		Y diameter		Z diameter	
	±0.015	(±0.38)	±0.015	(±0.38)	±0.015	(±0.38)
02	0.125	(3.2)	0.245	(6.2)	0.372	(9.4)
03	0.188	(4.8)	0.308	(7.8)	0.435	(11.0)
04	0.250	(6.4)	0.370	(9.4)	0.497	(12.6)
05	0.312	(7.9)	0.432	(11.0)	0.559	(14.2)
06	0.375	(9.5)	0.495	(12.6)	0.622	(15.9)
07	0.438	(11.1)	0.558	(14.2)	0.685	(17.4)
08	0.500	(12.7)	0.620	(15.7)	0.747	(19.0)
09	0.562	(14.3)	0.682	(17.3)	0.809	(20.5)
10	0.625	(15.9)	0.745	(18.9)	0.872	(22.1)
11	0.688	(17.5)	0.808	(20.5)	0.935	(23.7)
12	0.750	(19.1)	0.870	(22.1)	0.997	(25.3)
13	0.812	(20.6)	0.932	(23.7)	1.059	(26.9)
14	0.875	(22.2)	0.995	(25.3)	1.122	(28.5)
15	0.938	(23.8)	1.058	(26.9)	1.185	(30.1)
16	1.000	(25.4)	1.120	(28.4)	1.247	(31.7)
17	1.062	(27.0)	1.182	(30.0)	1.309	(33.2)
18	1.125	(28.6)	1.245	(31.6)	1.372	(34.8)
20	1.250	(31.8)	1.370	(34.8)	1.497	(38.0)

Notes

- 1 Metric dimensions are shown in parentheses for reference only.
- 2 When maximum cable entry is exceeded, style 2 will be supplied.
- 3 See Section 90 and 99 (See pages 162 and 169) for band termination selection and application tool data..

Tolerance

Unless otherwise specified:

.X ± .060 (1.5)

.XX ± .030 (0.8)

.XXX ± .015 (0.4)

Angles ± 5 degrees

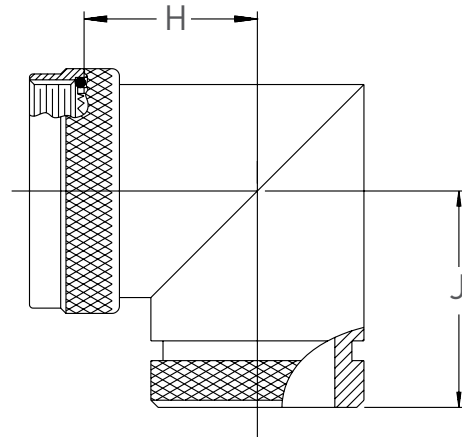
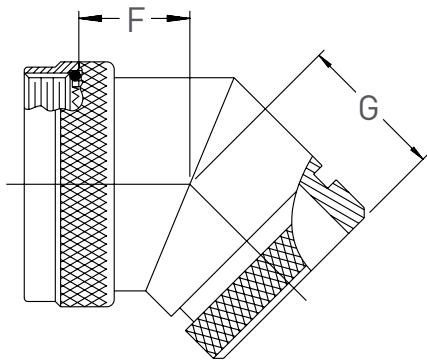
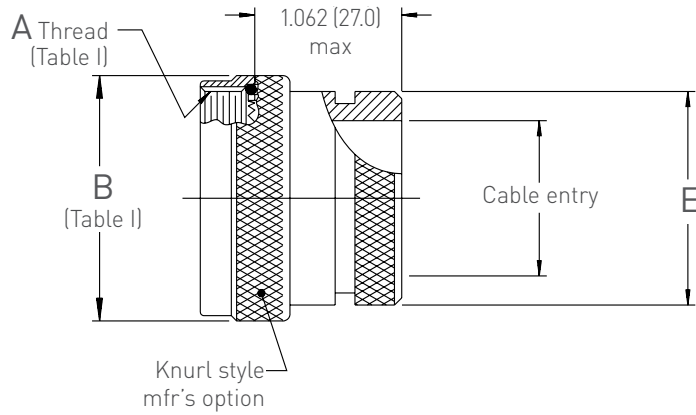

Example part number

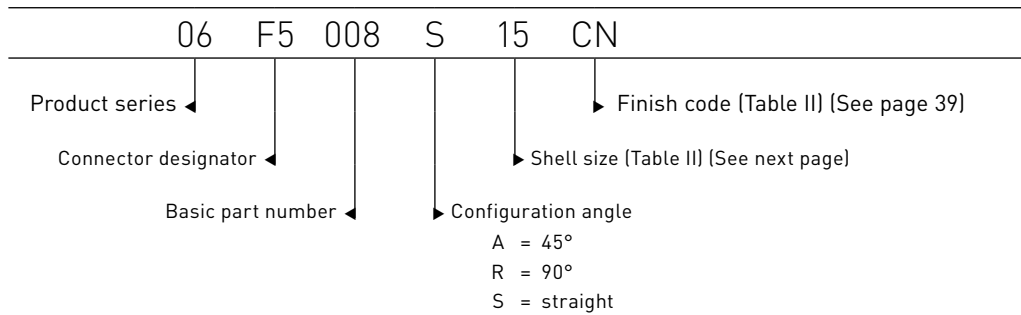

Table III

**Connector designator													
Shell size		E		F		G		H		J		Cable entry	
A1, F2, L1, X2	F5	max dimension		max dimension		max dimension		max dimension		max dimension		min dim	
08	09	0.533	(13.5)	0.612	(15.5)	0.800	(20.3)	0.727	(18.5)	0.936	(23.8)	0.250	(6.4)
10	11	0.605	(15.4)	0.675	(17.1)	0.828	(21.0)	0.831	(21.1)	0.992	(25.2)	0.355	(9.0)
12	13	0.774	(19.7)	0.698	(17.7)	0.851	(21.6)	0.886	(22.5)	1.048	(26.6)	0.491	(12.5)
14	15	0.838	(21.3)	0.723	(18.4)	0.876	(22.3)	0.946	(24.0)	1.114	(28.3)	0.565	(14.4)
16	17	0.963	(24.5)	0.748	(19.0)	0.901	(22.9)	1.008	(25.6)	1.172	(29.8)	0.690	(17.5)
18	19	1.042	(26.5)	0.767	(19.5)	0.920	(23.4)	1.052	(26.7)	1.233	(31.3)	0.769	(19.5)
20	21	1.217	(30.9)	0.793	(20.1)	0.946	(24.0)	1.115	(28.3)	1.303	(33.1)	0.894	(22.7)
22	23	1.355	(34.4)	0.818	(20.8)	0.971	(24.7)	1.177	(29.9)	1.356	(34.4)	1.019	(25.9)
24	25	1.443	(36.7)	0.844	(21.4)	0.997	(25.3)	1.240	(31.5)	1.424	(36.2)	1.134	(28.8)

* For connector family identification details see Page 17, Section I. Consult factory for availability of other connector designators not shown above.

Notes

- 1 Metric dimensions are shown in parentheses for reference only.
- 2 O-ring not supplied on connector designators A1 and L1. F2 is moisture proof only.
- 3 See shrink boot reference data, page 44.
- 4 Consult factory when cable entry diameter exceeds Z diameter (see page 41).

Tolerance

- Unless otherwise specified:
- .X ± .060 (1.5)
- .XX ± .030 (0.8)
- .XXX ± .015 (0.4)
- Angles ± 5 degrees

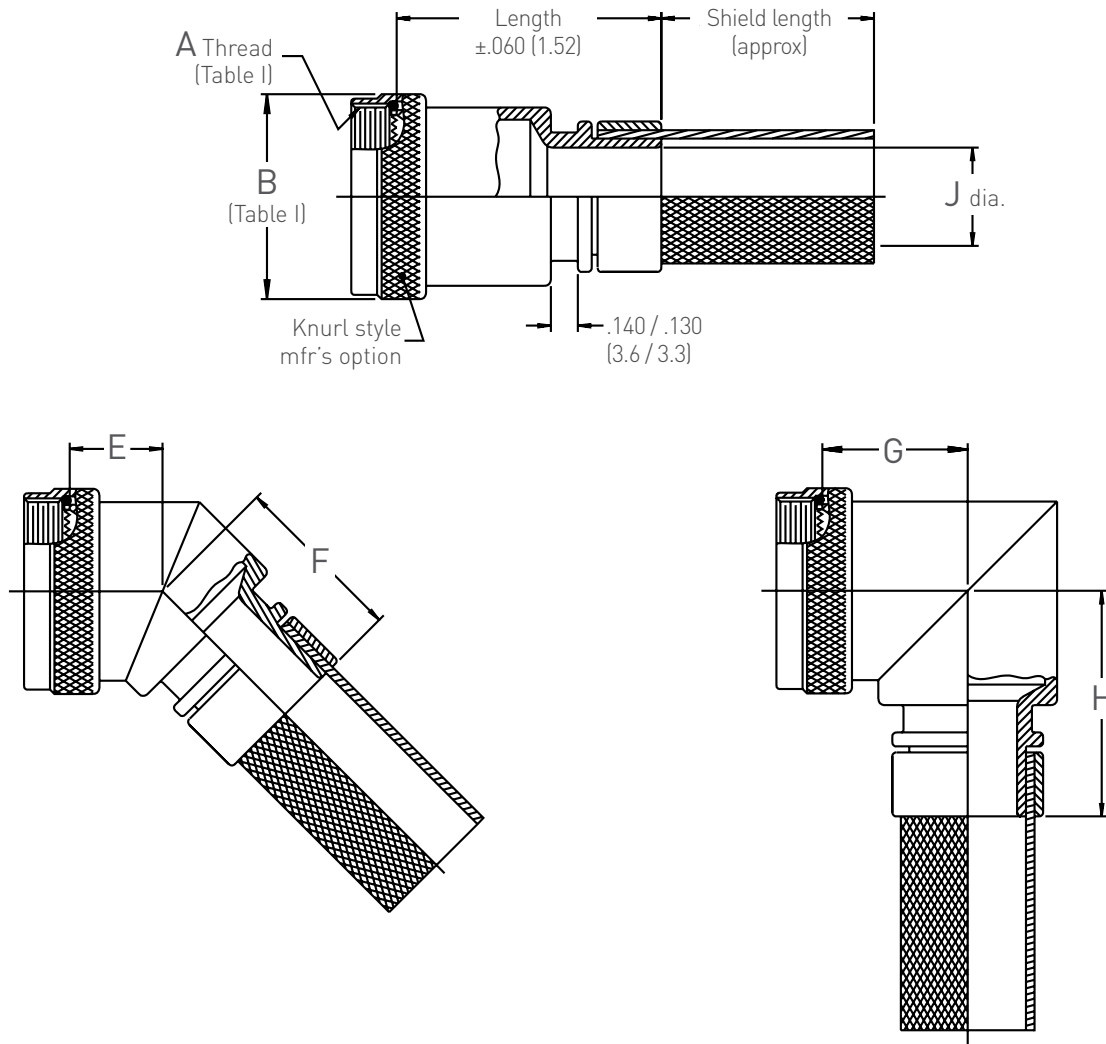

Example part number

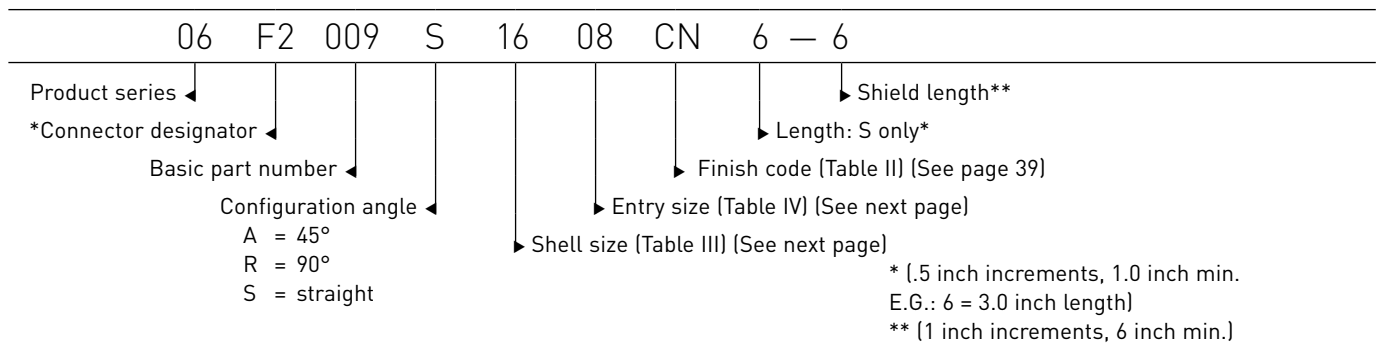

Table III

**Connector designator									
Shell size		E		F		G		H	
A1, F2, L1	F5	max dimension		max dimension		max dimension		max dimension	
08	09	0.612	(15.5)	1.018	(25.9)	0.727	(18.5)	1.155	(29.3)
10	11	0.675	(17.1)	1.046	(26.6)	0.831	(21.1)	1.211	(30.8)
12	13	0.698	(17.7)	1.069	(27.2)	0.886	(22.5)	1.267	(32.2)
14	15	0.723	(18.4)	1.094	(27.8)	0.946	(24.0)	1.333	(33.9)
16	17	0.748	(19.0)	1.119	(28.4)	1.008	(25.6)	1.391	(35.3)
18	19	0.767	(19.5)	1.138	(28.9)	1.052	(26.7)	1.452	(36.9)
20	21	0.793	(20.1)	1.164	(29.6)	1.115	(28.3)	1.522	(38.7)
22	23	0.818	(20.8)	1.189	(30.2)	1.177	(29.9)	1.575	(40.0)
24	25	0.844	(21.4)	1.215	(30.9)	1.240	(31.5)	1.643	(41.7)

* For connector family identification details see Page 17, Section I. Consult factory for availability of other connector designators not shown above.

Table IV

Entry size	J diameter	
01	0.188	(4.8)
02	0.250	(6.4)
03	0.312	(7.9)
04	0.375	(9.5)
05	0.438	(11.1)
06	0.500	(12.7)
07	0.562	(14.3)
08	0.625	(15.9)
09	0.688	(17.5)
10	0.750	(19.1)
11	0.812	(20.6)
12	0.875	(22.2)
13	0.938	(23.8)
14	1.000	(25.4)
16	1.500	(38.1)
15	1.250	(31.8)

Notes

- 1 Metric dimensions are shown in parentheses for reference only.
- 2 O-ring not supplied on connector designators A1 and L1. F2 is moisture proof only.
- 3 See shrink boot reference data, page 44.
- 4 Shield braid; tin copper, IAW QQ-B-575, ASTM-B33
- 5 Consult factory when cable entry diameter exceeds Z diameter (see page 41).

Tolerance

Unless otherwise specified:

- .X ± .060 (1.5)
- .XX ± .030 (0.8)
- .XXX ± .015 (0.4)
- Angles ± 5 degrees

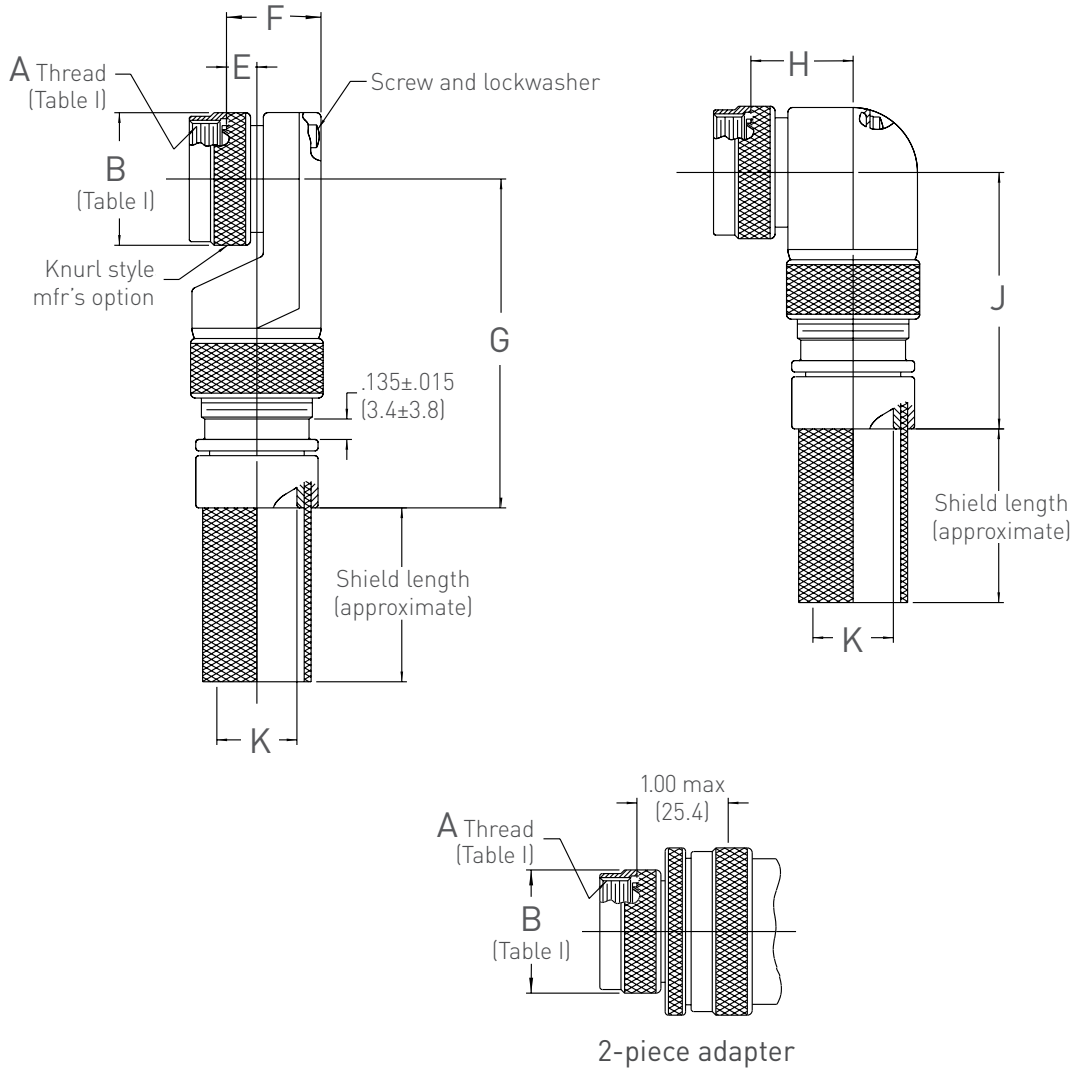

Example part number

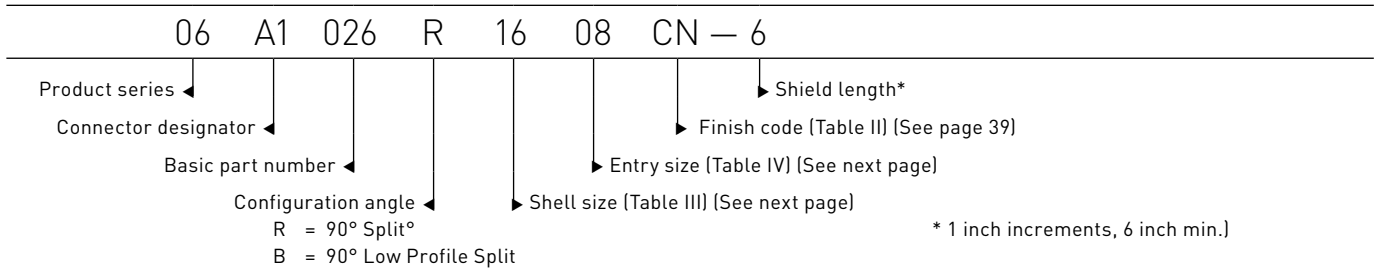

Table III

**Connector designator													
Shell size		E		F		G		H		J		Maximum entry size availability	
A1, F3, L1, X1	F4	max dimension		max dimension		max dimension		max dimension		max dimension		style B	style R
08	09	0.496	(12.6)	0.837	(21.3)	1.780	(45.2)	0.772	(19.6)	1.440	(36.6)	02	02
10	11	0.426	(10.8)	0.887	(22.5)	1.940	(49.3)	0.834	(21.2)	1.500	(38.1)	04	04
12	13	0.426	(10.8)	0.887	(22.5)	1.940	(49.3)	0.897	(22.8)	1.570	(39.9)	04	06
14	15	0.436	(11.1)	0.987	(25.1)	2.010	(51.1)	0.960	(24.4)	1.600	(40.6)	06	08
16	17	0.576	(14.6)	1.137	(28.9)	2.060	(52.3)	1.022	(26.0)	1.700	(43.2)	08	10
18	19	0.796	(20.2)	1.337	(34.0)	2.090	(53.1)	1.084	(27.5)	1.760	(44.7)	08	12
20	21	0.796	(20.2)	1.337	(34.0)	2.090	(53.1)	1.147	(29.1)	1.820	(46.2)	08	14
22	23	0.696	(17.7)	1.337	(34.0)	2.240	(56.9)	1.210	(30.7)	1.880	(47.8)	10	14
24	25	0.696	(17.7)	1.337	(34.0)	2.240	(56.9)	1.272	(32.3)	1.940	(49.3)	10	15

* For connector family identification details see Page 17, Section I. Consult factory for availability of other connector designators not shown above.

Table IV

Entry size	K diameter	
01	0.188	(4.8)
02	0.250	(6.4)
03	0.312	(7.9)
04	0.375	(9.5)
05	0.438	(11.1)
06	0.500	(12.7)
07	0.562	(14.3)
08	0.625	(15.9)
09	0.688	(17.5)
10	0.750	(19.1)
11	0.812	(20.6)
12	0.875	(22.2)
13	0.938	(23.8)
14	1.000	(25.4)
15	1.250	(31.8)
16	1.500	(38.1)
17	1.750	(44.5)

Notes

- 1 Metric dimensions are shown in parentheses for reference only.**
- 2 When maximum cable entry is exceeded, style 2 will be supplied.**
- 3 See shrink boot reference data, page 44.**
- 4 Shield braid; tin copper, IAW QQ-B-575, ASTM-B33**

Tolerance

Unless otherwise specified:

.X ± .060 (1.5)

.XX ± .030 (0.8)

.XXX ± .015 (0.4)

Angles ± 5 degrees

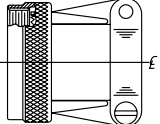
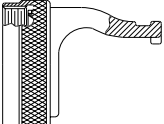
Basic part designator	Product page	Configuration description	
001	87 & 89	Medium to heavy duty clamps for applications requiring strain relief clamp bars with Sunbank's Self-seating captive spin coupling feature. Straight and angled configurations are offered for most connector series.	
021	91	Sunbank's Qk-Ty offers the self-seating captive spin coupler feature with reduced weight in a low profile configuration with simple installation strain relief for open wire bundles used on circular connectors.	

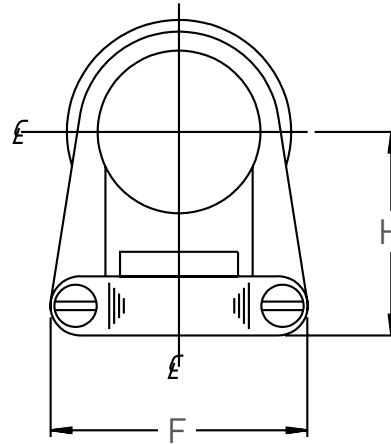
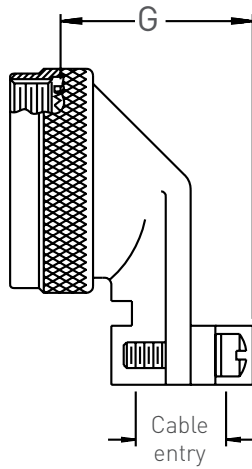
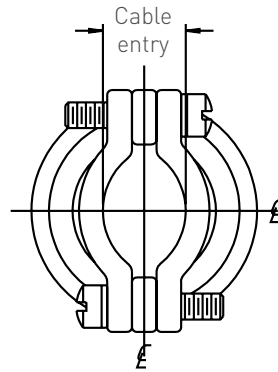
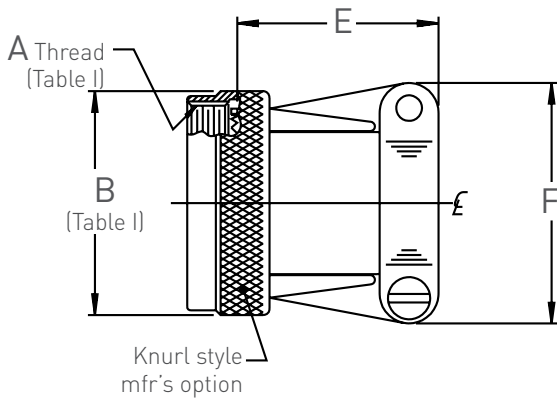

Example part number

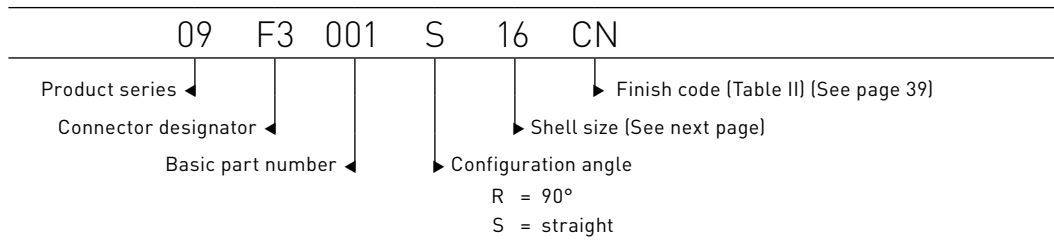

Table III

**Connector designator													
Shell size		E		F		G		H		Cable entry			
F3, X1	F4	max dimension		max dimension		max dimension		max dimension		min closed		max open	
08	09	0.910	(23.1)	0.850	(21.6)	1.160	(29.5)	1.000	(25.4)	0.098	(2.5)	0.234	(5.9)
10	11	0.910	(23.1)	0.900	(22.9)	1.160	(29.5)	1.100	(27.9)	0.153	(3.9)	0.234	(5.9)
12	13	1.010	(25.7)	1.100	(27.9)	1.240	(31.5)	1.100	(27.9)	0.190	(4.8)	0.328	(8.3)
14	15	1.060	(26.9)	1.150	(29.2)	1.410	(35.8)	1.250	(31.8)	0.260	(6.6)	0.457	(11.6)
16	17	1.160	(29.5)	1.300	(33.0)	1.580	(40.1)	1.300	(33.0)	0.283	(7.2)	0.614	(15.6)
18	19	1.410	(35.8)	1.500	(38.1)	1.600	(40.6)	1.350	(34.3)	0.325	(8.3)	0.634	(16.1)
20	21	1.510	(38.4)	1.600	(40.6)	1.680	(42.7)	1.600	(40.6)	0.343	(8.7)	0.698	(17.7)
22	23	1.660	(42.2)	1.700	(43.2)	1.820	(46.2)	1.750	(44.5)	0.381	(9.7)	0.823	(20.9)
24	25	1.760	(44.7)	1.800	(45.7)	1.930	(49.0)	1.850	(47.0)	0.418	(10.6)	0.853	(21.7)

* For connector family identification details see Page 17, Section I. Consult factory for availability of other connector designators not shown above.

Notes

- 1 Metric dimensions are shown in parentheses for reference only.
- 2 Cable entry is defined as the envelope area of the cable or wire bundle. It is not intended for inspection criteria.
- 3 Not recommended for size 8, 4 and 0 contacts.

Tolerance

Unless otherwise specified:

- .X ± .060 (1.5)
- .XX ± .030 (0.8)
- .XXX ± .015 (0.4)
- Angles ± 5 degrees

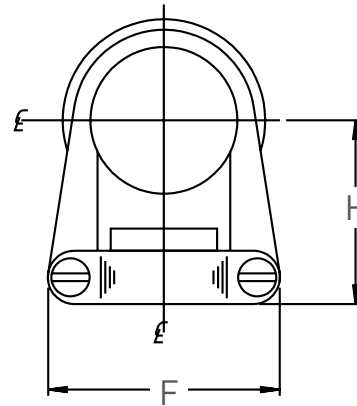
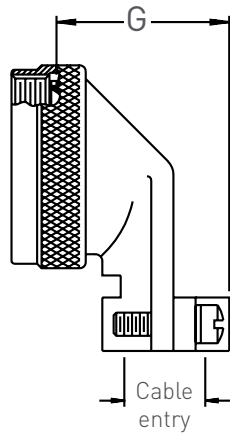
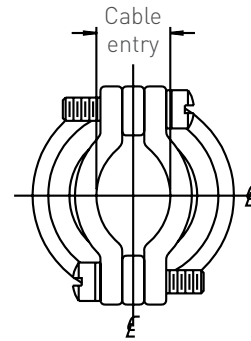
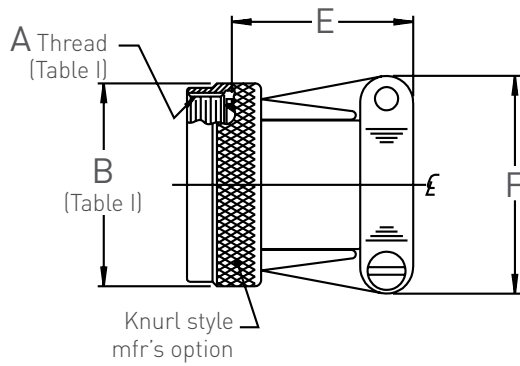

Example part number

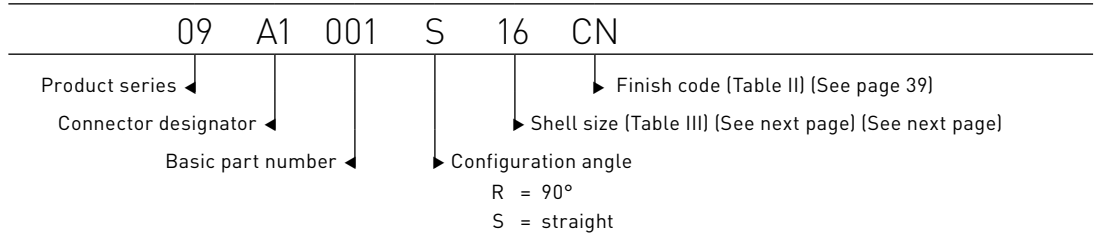

Table III

**Connector designator												
Shell size A1 & L1	E max dimension		F max dimension		G max dimension		H max dimension		Cable entry min closed		max open	
08	0.630	(16.0)	0.752	(19.1)	0.780	(19.8)	0.808	(20.5)	0.125	(3.2)	0.204	(5.2)
10	0.740	(18.8)	0.832	(21.1)	0.860	(21.8)	0.867	(22.0)	0.187	(4.7)	0.286	(7.3)
12	0.860	(21.8)	0.988	(25.1)	1.050	(26.7)	0.929	(23.6)	0.291	(7.4)	0.416	(10.6)
14	0.860	(21.8)	1.046	(26.6)	1.110	(28.2)	0.992	(25.2)	0.351	(8.9)	0.476	(12.1)
16	1.000	(25.4)	1.319	(33.5)	1.260	(32.0)	1.056	(26.8)	0.501	(12.7)	0.625	(15.9)
18	1.240	(31.5)	1.451	(36.9)	1.370	(34.8)	1.233	(31.3)	0.518	(13.2)	0.706	(17.9)
20	1.360	(34.5)	1.557	(39.5)	1.500	(38.1)	1.296	(32.9)	0.581	(14.8)	0.831	(21.1)
22	1.490	(37.8)	1.653	(42.0)	1.620	(41.1)	1.358	(34.5)	0.644	(16.4)	0.956	(24.3)
24	1.610	(40.9)	1.775	(45.1)	1.750	(44.5)	1.420	(36.1)	0.706	(17.9)	1.081	(27.5)
28	1.760	(44.7)	2.020	(51.3)	1.890	(48.0)	1.634	(41.5)	0.750	(19.1)	1.187	(30.1)

* For connector family identification details see Page 17, Section I. Consult factory for availability of other connector designators not shown above.

Notes

- 1 Metric dimensions are shown in parentheses for reference only.
- 2 Cable entry is defined as the envelope area of the cable or wire bundle. It is not intended for inspection criteria.
- 3 Not recommended for size 8, 4 and 0 contacts.

Tolerance

Unless otherwise specified:

- .X ± .060 (1.5)
- .XX ± .030 (0.8)
- .XXX ± .015 (0.4)
- Angles ± 5 degrees

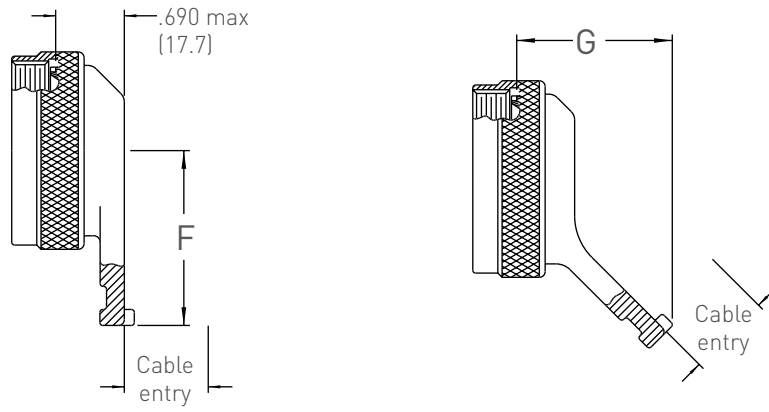
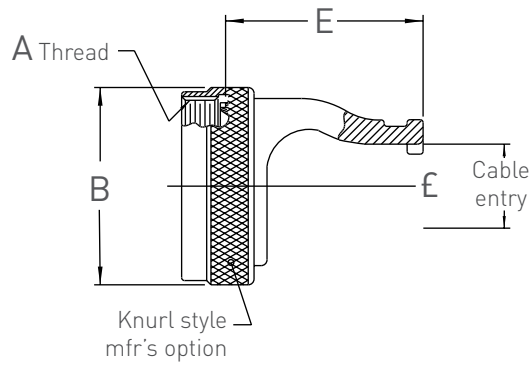

Example part number

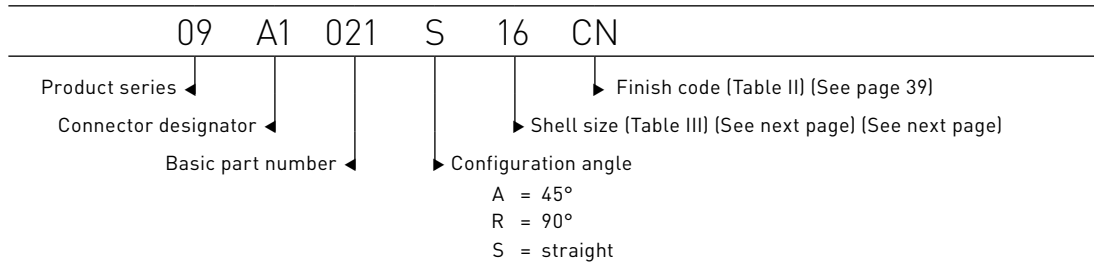

Table III

**Connector designator	E		F		G		Cable entry	
Shell size	max dimension		max dimension		max dimension			
A1								
08	0.923	(23.4)	0.89	(22.4)	1.123	(28.5)	0.260	(6.6)
10	0.955	(24.3)	0.95	(23.9)	1.155	(29.3)	0.365	(9.3)
12	1.014	(25.8)	1.01	(25.4)	1.155	(29.3)	0.501	(12.7)
14	1.191	(30.3)	1.33	(33.5)	1.277	(32.4)	0.575	(14.6)
16	1.191	(30.3)	1.39	(35.1)	1.315	(33.4)	0.700	(17.8)
18	1.265	(32.1)	1.46	(37.1)	1.315	(33.4)	0.779	(19.8)
20	1.395	(35.4)	1.51	(38.4)	1.315	(33.4)	0.904	(23.0)
22	1.514	(38.5)	1.51	(39.6)	1.315	(33.4)	1.029	(26.1)
24	1.644	(41.8)	1.64	(41.4)	1.315	(33.4)	1.144	(29.1)

* For connector family identification details see Page 17, Section I. Consult factory for availability of other connector designators not shown above.

Notes

- 1 Metric dimensions are shown in parentheses for reference only.
- 2 Cable entry is defined as the envelope area of the cable or wire bundle. It is not intended for inspection criteria.
- 3 Not recommended for size 8, 4 and 0 contacts.
- 4 Cable bundle is secured using a MS3367-1 tie strap or equivalent.

Tolerance

- Unless otherwise specified:
- .X ± .060 (1.5)
- .XX ± .030 (0.8)
- .XXX ± .015 (0.4)
- Angles ± 5 degrees

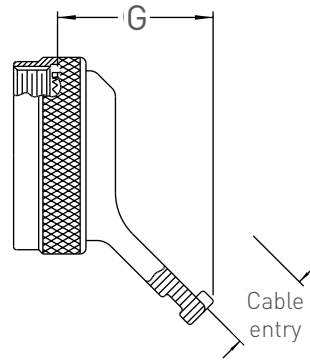
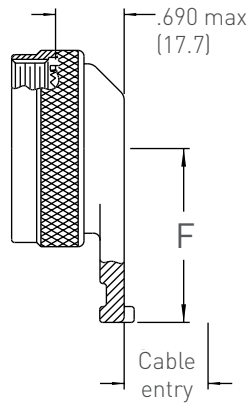
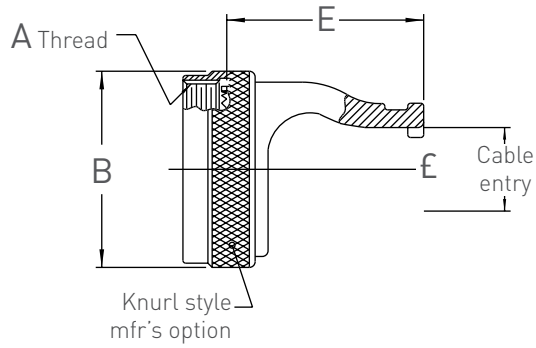

Example part number

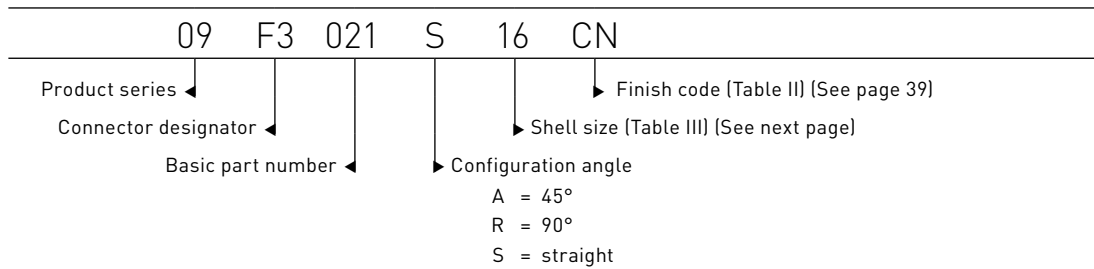

Table III

**Connector designator											
Shell size		E		F		G		Cable entry			
F3	F4	max dia		max dimension		max dimension		F3		F4	
08	09	1.004	(25.5)	0.89	(22.4)	1.204	(30.6)	0.264	(6.7)	0.250	(6.4)
10	11	1.034	(26.3)	0.95	(23.9)	1.234	(31.3)	0.392	(10.0)	0.382	(9.7)
12	13	1.093	(27.8)	1.07	(27.3)	1.234	(31.3)	0.506	(12.9)	0.500	(12.7)
14	15	1.270	(32.3)	1.33	(33.5)	1.356	(34.4)	0.631	(16.0)	0.630	(16.0)
16	17	1.270	(32.3)	1.39	(35.1)	1.394	(35.4)	0.756	(19.2)	0.750	(19.1)
18	19	1.344	(34.1)	1.48	(37.6)	1.394	(35.4)	0.845	(21.5)	0.838	(21.3)
20	21	1.474	(37.4)	1.66	(42.3)	1.394	(35.4)	0.970	(24.6)	0.968	(24.6)
22	23	1.593	(40.5)	1.85	(47.0)	1.394	(35.4)	1.095	(27.8)	1.090	(27.7)
24	25	1.723	(43.8)	1.91	(48.5)	1.394	(35.4)	1.220	(31.0)	1.220	(31.0)

* For connector family identification details see Page 17, Section I. Consult factory for availability of other connector designators not shown above.

Notes

- 1 Metric dimensions are shown in parentheses for reference only.
- 2 Cable entry is defined as the envelope area of the cable or wire bundle. It is not intended for inspection criteria.
- 3 Not recommended for size 8, 4 and 0 contacts.
- 4 Cable bundle is secured using a MS3367-1 tie strap or equivalent.

Tolerance

Unless otherwise specified:

- .X ± .060 (1.5)
- .XX ± .030 (0.8)
- .XXX ± .015 (0.4)
- Angles ± 5 degrees

Basic part designator	Product page	Configuration description
001	97	Adapter extenders with the self-seating spin coupling feature providing an extension behind the connector to accommodate standard strain relief clamps or other adapter accessories normally used with the connector.

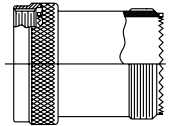

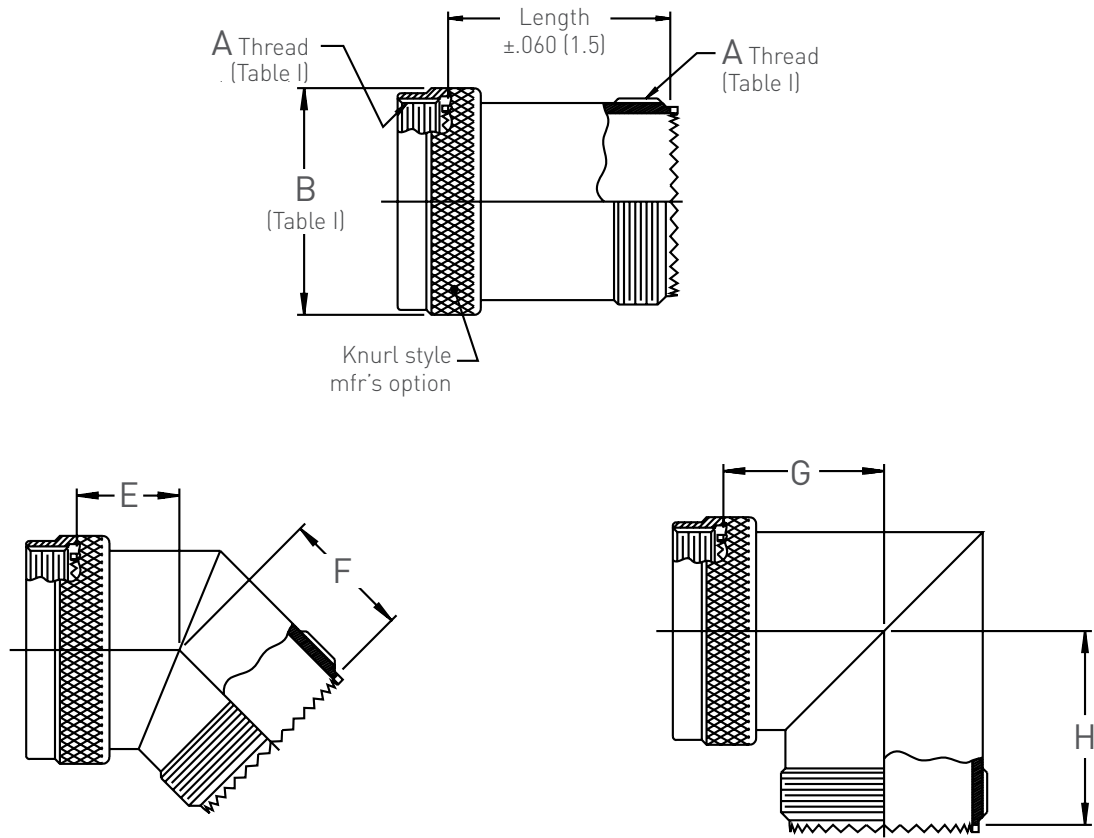

Example part number

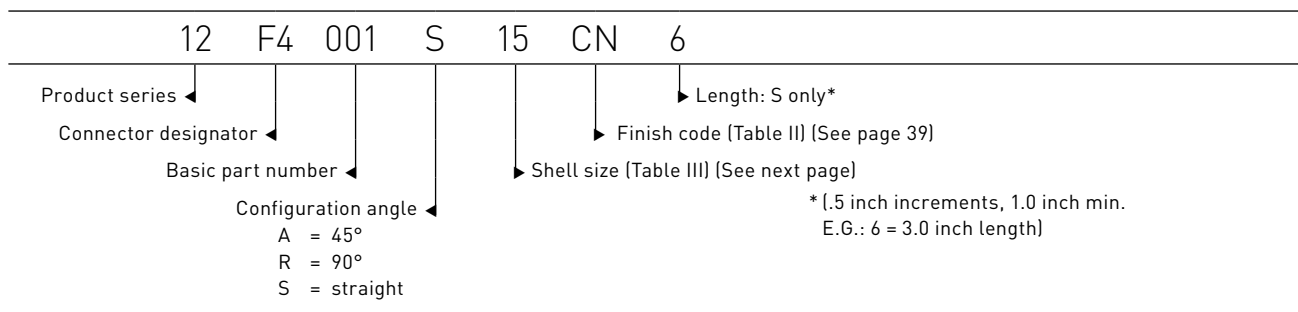

Table III

**Connector designator		E		F		G		H	
Shell size		max dimension		max dimension		max dimension		max dimension	
A1, F3, L1, X1	F4								
08	09	0.546	(13.9)	.0674	(17.1)	.0661	(16.8)	0.874	(22.2)
10	11	0.609	(15.5)	0.702	(17.8)	0.765	(19.4)	0.930	(23.6)
12	13	0.632	(16.1)	0.725	(18.4)	0.820	(20.8)	0.986	(25.0)
14	15	0.657	(16.7)	0.750	(19.1)	0.880	(22.4)	1.052	(26.7)
16	17	0.682	(17.3)	0.775	(19.7)	0.942	(23.9)	1.110	(28.2)
18	19	0.701	(17.8)	0.794	(20.2)	0.986	(25.0)	1.171	(29.7)
20	21	0.727	(18.5)	0.820	(20.8)	1.049	(26.6)	1.241	(31.5)
22	23	0.752	(19.1)	0.845	(21.5)	1.111	(28.2)	1.294	(32.9)
24	25	0.778	(19.8)	0.871	(22.1)	1.174	(29.8)	1.362	(34.6)

* For connector family identification details see Page 17, Section I. Consult factory for availability of other connector designators not shown above.

Notes

1 Metric dimensions are shown in parentheses for reference only.

Tolerance

Unless otherwise specified:

.X ± .060 (1.5)

.XX ± .030 (0.8)

.XXX ± .015 (0.4)

Angles ± 5 degrees



Basic part designator	Product page	Configuration description
001	101	Adapters with the Self-seating spin coupling feature accommodating medium to heavy duty strain relief clamps in straight and angled configurations.

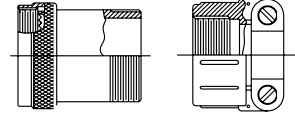

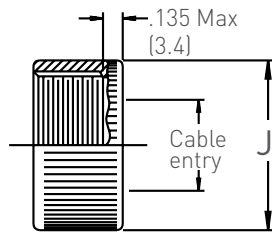
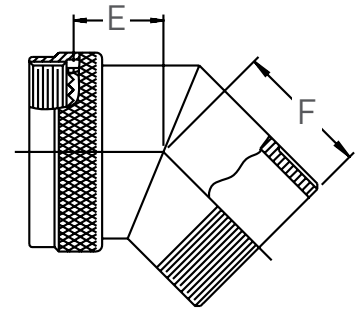
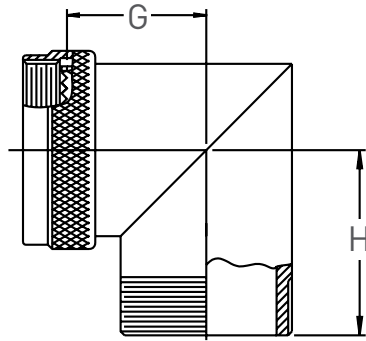
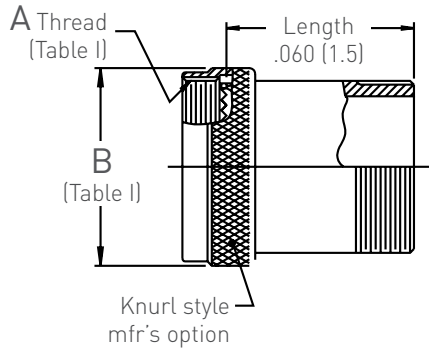

Style C (Table IV)

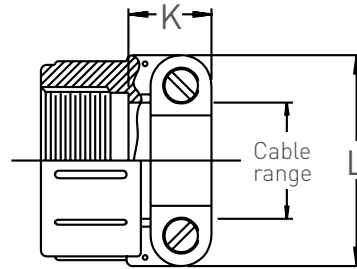

Style A (Table IV)

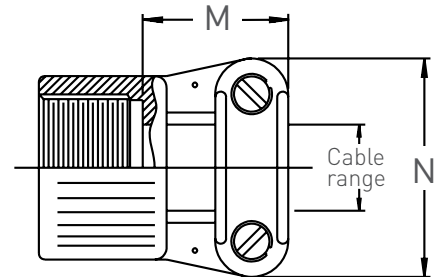

Style F (Table IV)

Example part number

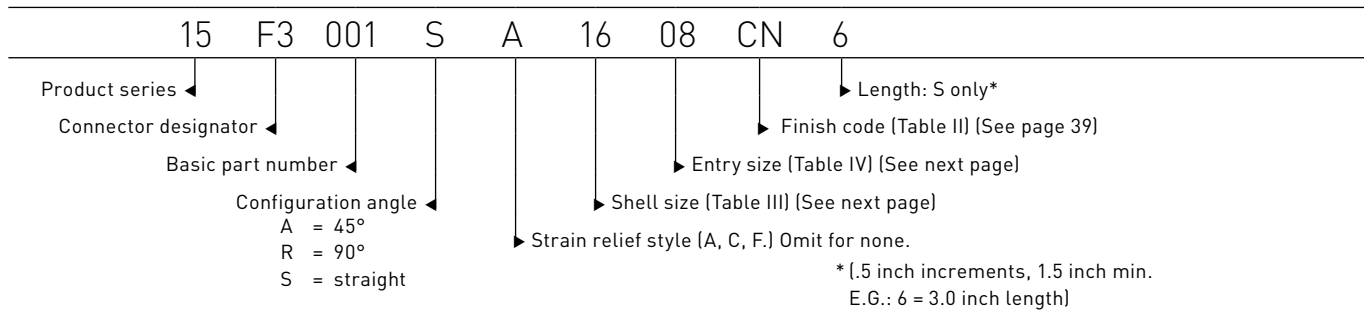

Table III

**Connector designator		E		F		G		H	
Shell size		max dimension		max dimension		max dimension		max dimension	
A1, F3, L1, X1	F4								
08	09	0.546	(13.9)	1.300	(33.0)	0.661	(16.8)	1.499	(38.1)
10	11	0.609	(15.5)	1.328	(33.7)	0.765	(19.4)	1.561	(39.6)
12	13	0.632	(16.1)	1.351	(34.3)	0.820	(20.8)	1.619	(41.1)
14	15	0.657	(16.7)	1.376	(35.0)	0.880	(22.4)	1.677	(42.6)
16	17	0.682	(17.3)	1.401	(35.6)	0.942	(23.9)	1.735	(44.1)
18	19	0.701	(17.8)	1.420	(36.1)	0.986	(25.0)	1.796	(45.6)
20	21	0.727	(18.5)	1.446	(36.7)	1.049	(26.6)	1.866	(47.4)
22	23	0.752	(19.1)	1.471	(37.4)	1.111	(28.2)	1.919	(48.7)
24	25	0.778	(19.8)	1.497	(38.0)	1.174	(29.8)	1.987	(50.5)

* For connector family identification details see Page 17, Section I. Consult factory for availability of other connector designators not shown above.

Table IV

Entry size	J		K		L		M		N		Cable range			
	max		max		max		max		max		min	max		
03	0.656	(16.7)	0.453	(11.5)	0.843	(21.4)	N/A		N/A		0.156	(4.0)	0.250	(6.4)
04	0.781	(19.8)	0.453	(11.5)	0.906	(23.0)	0.780	(19.8)	0.957	(24.3)	0.187	(4.7)	0.312	(7.9)
06	0.906	(23.0)	0.516	(13.1)	1.093	(27.8)	0.780	(19.8)	1.145	(29.1)	0.281	(7.1)	0.438	(11.1)
08	1.031	(26.2)	0.579	(14.7)	1.187	(30.1)	0.780	(19.8)	1.332	(33.8)	0.344	(8.7)	0.562	(14.3)
10	1.156	(29.4)	0.579	(14.7)	1.281	(32.5)	0.780	(19.8)	1.332	(33.8)	0.375	(9.5)	0.625	(15.9)
12	1.344	(34.1)	0.579	(14.7)	1.500	(38.1)	0.811	(20.6)	1.551	(39.4)	0.438	(11.1)	0.750	(19.1)
16	1.594	(40.5)	0.672	(17.1)	1.719	(43.7)	0.905	(23.0)	1.770	(45.0)	0.562	(14.3)	0.938	(23.8)
20	1.906	(48.4)	0.672	(17.1)	2.062	(52.4)	1.092	(27.7)	2.113	(53.7)	0.750	(19.1)	1.250	(31.8)
24	2.156	(54.8)	0.672	(17.1)	2.312	(58.7)	1.124	(28.5)	2.363	(60.0)	0.781	(19.8)	1.375	(34.9)
32	2.656	(67.5)	1.204	(30.6)	2.969	(75.4)	1.399	(35.5)	3.020	(76.7)	1.125	(28.6)	1.875	(47.6)
40	3.158	(80.2)	1.141	(29.0)	3.351	(89.7)	N/A		N/A		1.469	(37.3)	2.375	(60.3)

Notes

- Metric dimensions are shown in parentheses for reference only.
- Cable range is defined as the envelope area of the cable or wire bundle. It is not intended for inspection criteria.
- Consult factory when cable entry diameter exceeds Z diameter (see page 41).

Tolerance

Unless otherwise specified:
 .X ± .060 (1.5)
 .XX ± .030 (0.8)
 .XXX ± .015 (0.4)
 Angles ± 5 degrees

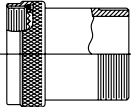
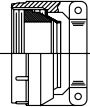
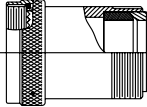
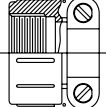

Basic part designator	Product page	Configuration description		
001	105	Self-seating spin coupling adapters with environmental cable sealing strain relief clamps in straight and angled configurations for connector to cable accommodations.		
002	107	Environmental cable sealing adapters with the self-seating spin coupling feature and strain relief clamp accommodations in straight and angled configurations.		

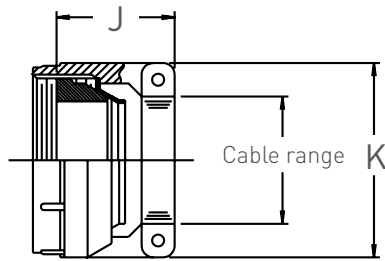
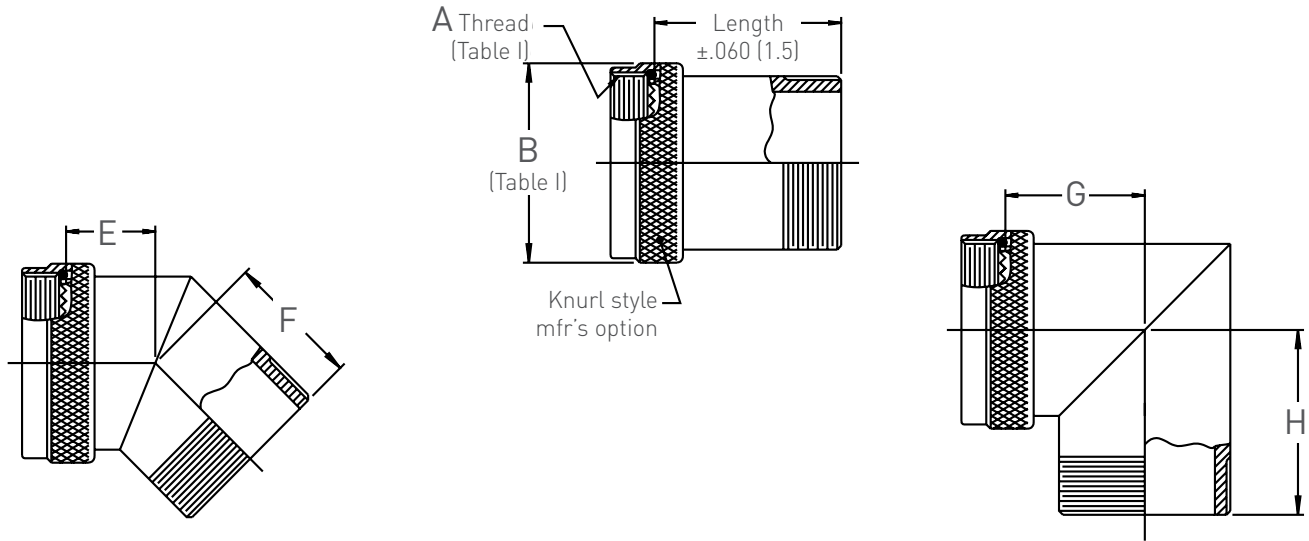

Style E
(Table IV)

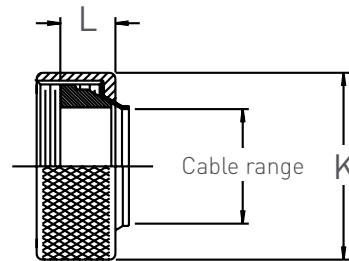

Style G
(Table IV)

Example part number

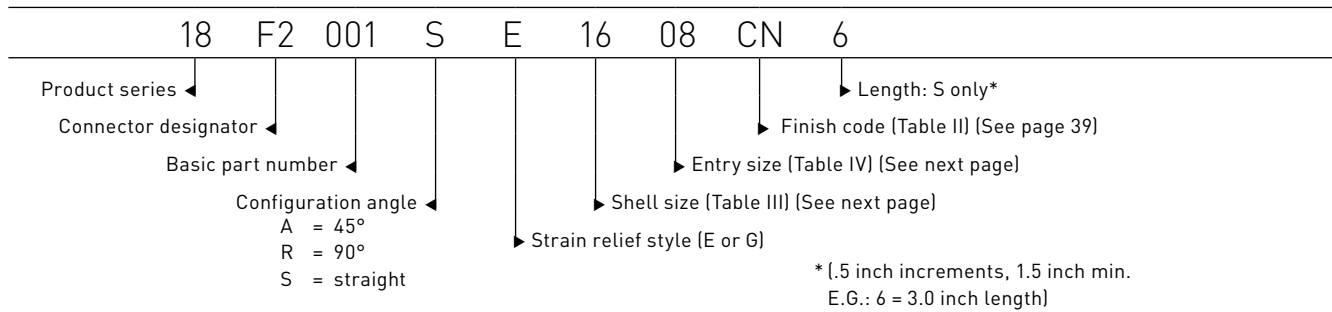

Table III

**Connector designator		E		F		G		H	
Shell size		max dimension		max dimension		max dimension		max dimension	
A1, F2, L1, X2	F5								
08	09	0.612	(15.5)	1.300	(33.0)	0.727	(18.5)	1.499	(38.1)
10	11	0.675	(17.1)	1.328	(33.7)	0.831	(21.1)	1.561	(39.6)
12	13	0.698	(17.7)	1.351	(34.3)	0.886	(22.5)	1.619	(41.1)
14	15	0.723	(18.4)	1.376	(35.0)	0.946	(24.0)	1.677	(42.6)
16	17	0.748	(19.0)	1.401	(35.6)	1.008	(25.6)	1.735	(44.1)
18	19	0.767	(19.5)	1.420	(36.1)	1.052	(26.7)	1.796	(45.6)
20	21	0.793	(20.1)	1.446	(36.7)	1.115	(28.3)	1.866	(47.4)
22	23	0.818	(20.8)	1.471	(37.4)	1.177	(29.9)	1.919	(48.7)
24	25	0.844	(21.4)	1.497	(38.0)	1.240	(31.5)	1.987	(50.5)

* For connector family identification details see Page 17, Section I. Consult factory for availability of other connector designators not shown above.

Table IV

Entry size	J		K		L		Cable range			
	max		max		max		min		max	
03	1.219	(31.0)	0.812	(20.6)	0.578	(14.7)	0.156	(4.0)	0.219	(5.6)
04	1.219	(31.0)	0.937	(23.8)	0.578	(14.7)	0.188	(4.8)	0.312	(7.9)
06	1.219	(31.0)	1.062	(27.0)	0.578	(14.7)	0.250	(6.4)	0.438	(11.1)
08	1.219	(31.0)	1.188	(30.2)	0.578	(14.7)	0.312	(7.9)	0.531	(13.5)
10	1.281	(32.5)	1.132	(33.3)	0.594	(15.1)	0.375	(9.5)	0.625	(15.9)
12	1.281	(32.5)	1.562	(39.7)	0.656	(16.7)	0.500	(12.7)	0.750	(19.1)
16	1.406	(35.7)	1.750	(44.5)	0.656	(16.7)	0.700	(17.8)	0.938	(23.8)
20	1.656	(42.1)	2.250	(57.2)	0.734	(18.6)	0.926	(23.5)	1.250	(31.8)
24	1.906	(48.4)	2.375	(60.3)	0.953	(24.2)	1.125	(28.6)	1.375	(34.9)
28	1.906	(48.4)	2.625	(66.7)	0.953	(24.2)	1.312	(33.3)	1.625	(41.3)
32	2.000	(50.8)	2.812	(71.4)	1.093	(27.8)	1.500	(38.1)	1.875	(47.6)

Notes

- Metric dimensions are shown in parentheses for reference only.
- O-ring not supplied on connector designators A1 and L1. F2 is moisture proof only.
- Cable range is defined as the envelope area of the cable or wire bundle. It is not intended for inspection criteria.
- Consult factory when cable entry diameter exceeds Z diameter (see page 41).

Tolerance

- Unless otherwise specified:
- .X ± .060 (1.5)
 - .XX ± .030 (0.8)
 - .XXX ± .015 (0.4)
 - Angles ± 5 degrees

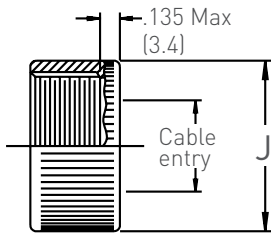
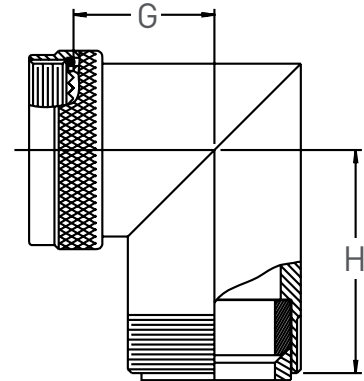
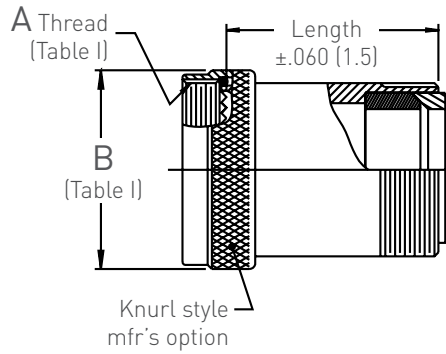
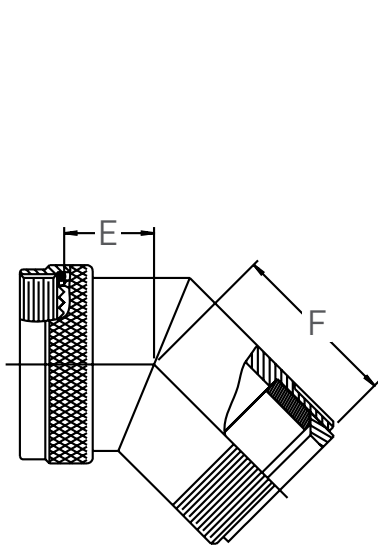

Style C
(Table IV)

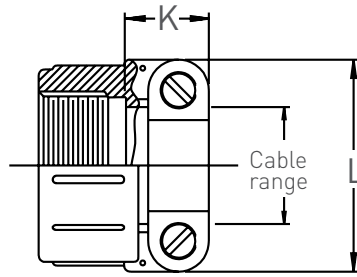

Style A
(Table IV)

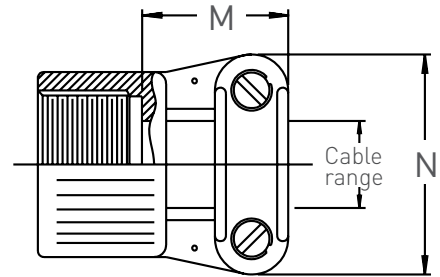

Style F
(Table IV)

Example part number

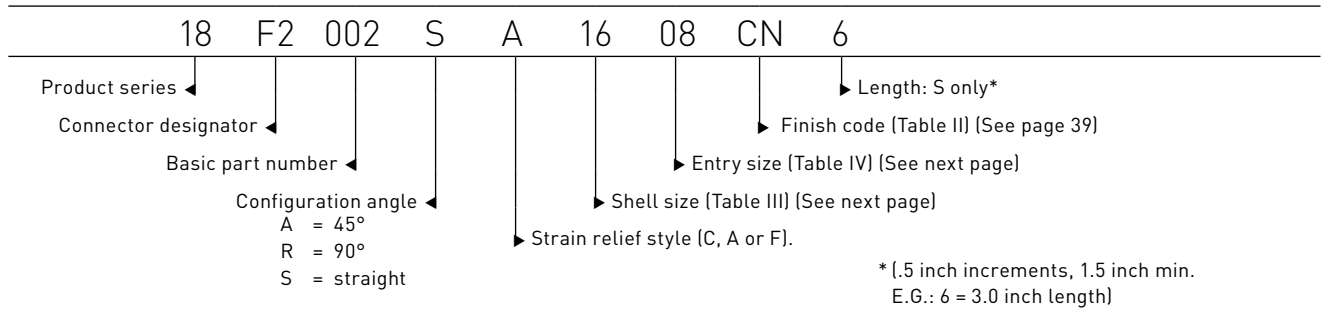

Table III

*Connector designator									
Shell size		E		F		G		H	
A1, F2, L1, X2	F5	max dimension		max dimension		max dimension		max dimension	
08	09	0.612	(15.5)	1.300	(33.0)	0.727	(18.5)	1.499	(38.1)
10	11	0.675	(17.1)	1.328	(33.7)	0.831	(21.1)	1.561	(39.6)
12	13	0.698	(17.7)	1.351	(34.3)	0.886	(22.5)	1.619	(41.1)
14	15	0.723	(18.4)	1.376	(35.0)	0.946	(24.0)	1.677	(42.6)
16	17	0.748	(19.0)	1.401	(35.6)	1.008	(25.6)	1.735	(44.1)
18	19	0.767	(19.5)	1.420	(36.1)	1.052	(26.7)	1.796	(45.6)
20	21	0.793	(20.1)	1.446	(36.7)	1.115	(28.3)	1.866	(47.4)
22	23	0.818	(20.8)	1.471	(37.4)	1.177	(29.9)	1.919	(48.7)
24	25	0.844	(21.4)	1.497	(38.0)	1.240	(31.5)	1.987	(50.5)

* For connector family identification details see Page 17, Section I. Consult factory for availability of other connector designators not shown above.

Table IV

Entry	J		K		L		M		N		Cable range			
size	max		max		max		max		max		min	max		
03	0.656	(16.7)	0.453	(11.5)	0.843	(21.4)	N/A		N/A		0.156	(4.0)	0.250	(6.4)
04	0.781	(19.8)	0.453	(11.5)	0.906	(23.0)	0.780	(19.8)	0.957	(24.3)	0.187	(4.7)	0.312	(7.9)
06	0.906	(23.0)	0.516	(13.1)	1.093	(27.8)	0.780	(19.8)	1.145	(29.1)	0.281	(7.1)	0.438	(11.1)
08	1.031	(26.2)	0.579	(14.7)	1.187	(30.1)	0.780	(19.8)	1.332	(33.8)	0.344	(8.7)	0.562	(14.3)
10	1.156	(29.4)	0.579	(14.7)	1.281	(32.5)	0.780	(19.8)	1.332	(33.8)	0.375	(9.5)	0.625	(15.9)
12	1.344	(34.1)	0.579	(14.7)	1.500	(38.1)	0.811	(20.6)	1.551	(39.4)	0.438	(11.1)	0.750	(19.1)
16	1.594	(40.5)	0.672	(17.1)	1.719	(43.7)	0.905	(23.0)	1.770	(45.0)	0.562	(14.3)	0.938	(23.8)
20	1.906	(48.4)	0.672	(17.1)	2.062	(52.4)	1.092	(27.7)	2.113	(53.7)	0.750	(19.1)	1.250	(31.8)
24	2.156	(54.8)	0.672	(17.1)	2.312	(58.7)	1.124	(28.5)	2.363	(60.0)	0.781	(19.8)	1.375	(34.9)
28	2.406	(61.1)	1.204	(30.6)	2.719	(69.1)	1.399	(35.5)	2.770	(70.4)	0.969	(24.6)	1.625	(41.3)
32	2.656	(67.5)	1.204	(30.6)	2.969	(75.4)	1.399	(35.5)	3.020	(76.7)	1.125	(28.6)	1.875	(47.6)
40	3.156	(80.2)	1.141	(29.0)	3.531	(89.7)	N/A		N/A		1.469	(37.3)	2.375	(60.3)

Notes

- Metric dimensions are shown in parentheses for reference only.
- O-ring not supplied on connector designators A1 and L1. F2 is moisture proof only.
- Cable range is defined as the envelope area of the cable or wire bundle. It is not intended for inspection criteria.
- Consult factory when cable entry diameter exceeds Z diameter (see page 41).

Tolerance

- Unless otherwise specified:
- .X ± .060 (1.5)
 - .XX ± .030 (0.8)
 - .XXX ± .015 (0.4)
 - Angles ± 5 degrees



Basic part designator	Product page	Configuration description		
001 015	110 113	EMI/RFI adapters with self-seating spin coupling feature, light weight, external cone/ring termination and strain relief in straight and angled configurations for overall or individual shield terminating.		
002 013	115 117	EMI/RFI adapters with self-seating spin coupling with or without strain relief clamps for overall or individual shields utilizing a single ring in straight or angled configurations.		
003 011	119 121	EMI/RFI adapters with the self-seating spin coupling utilizing two or three ring termination for overall or individual shield termination with or without strain relief in straight and angled configurations.		
004 018	123 125	EMI/RFI adapters with the self-seating spin coupling with dual recessed termination rings with or without strain relief for overall shield termination in straight and angled configurations.		

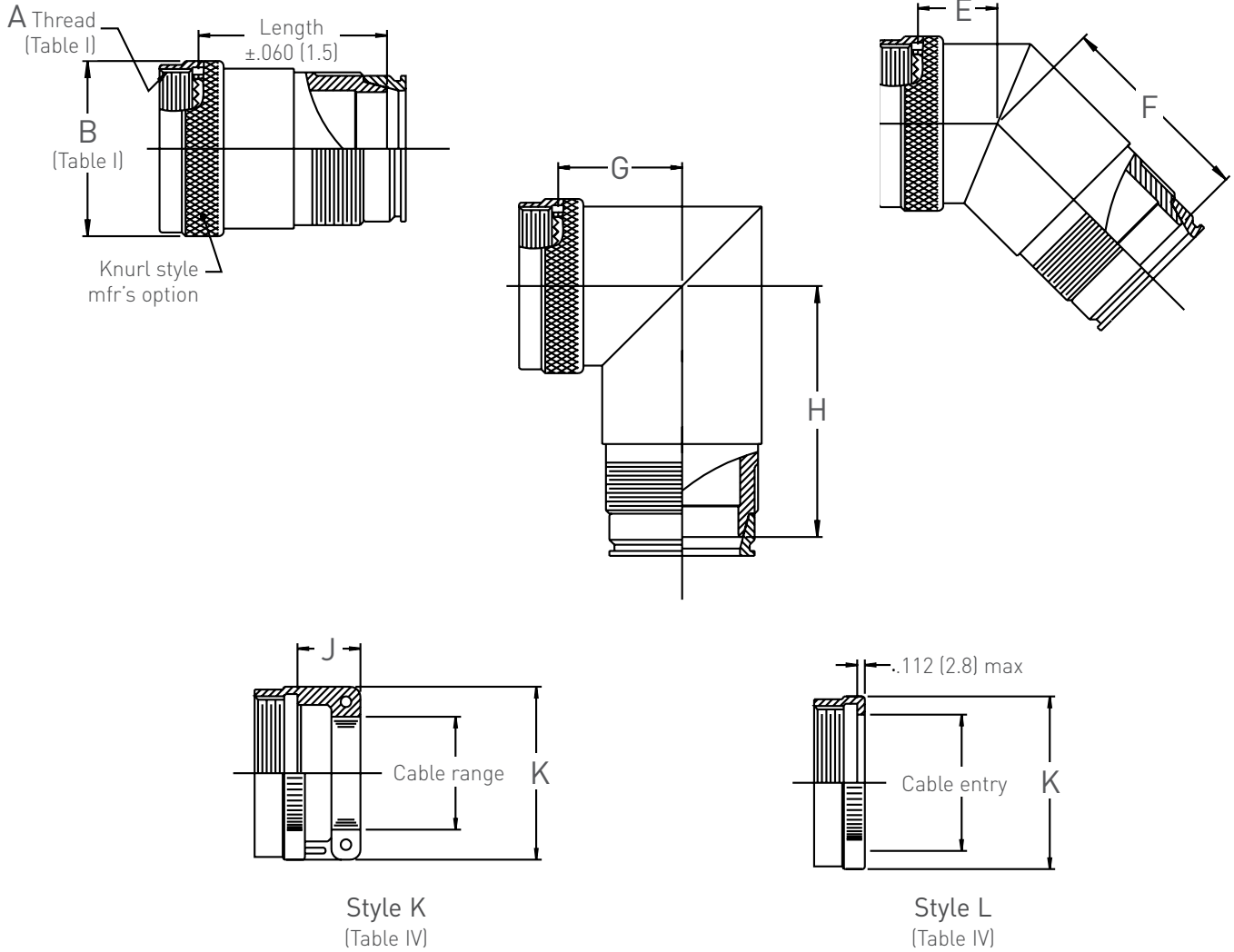

Example part number

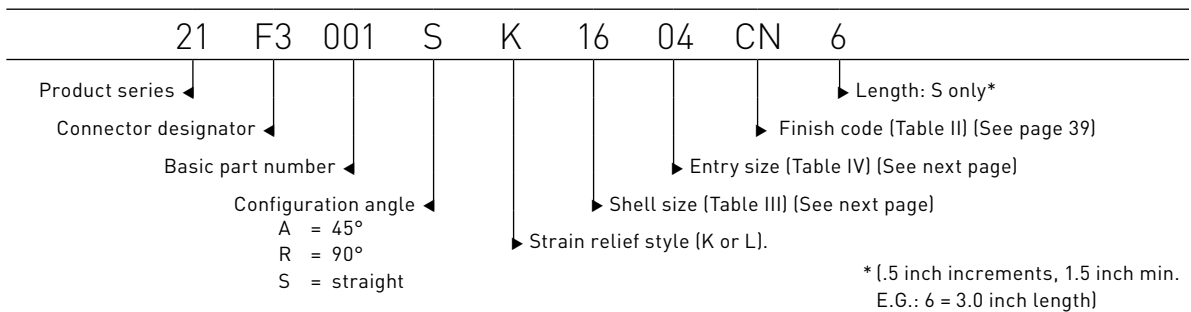

Table III

*Connector designator									
Shell size		E		F		G		H	
A1, F3, L1, X1	F4	max dimension		max dimension		max dimension		max dimension	
08	09	0.546	(13.9)	1.143	(29.0)	0.661	(16.8)	1.312	(33.3)
10	11	0.609	(15.5)	1.173	(29.8)	0.765	(19.4)	1.368	(34.7)
12	13	0.632	(16.1)	1.194	(30.3)	0.820	(20.8)	1.424	(36.2)
14	15	0.657	(16.7)	1.219	(31.0)	0.880	(22.4)	1.490	(37.8)
16	17	0.682	(17.3)	1.244	(31.6)	0.942	(23.9)	1.548	(39.3)
18	19	0.701	(17.8)	1.263	(32.1)	0.986	(25.0)	1.609	(40.9)
20	21	0.727	(18.5)	1.289	(32.7)	1.049	(26.6)	1.679	(42.6)
22	23	0.752	(19.1)	1.314	(33.4)	1.111	(28.2)	1.732	(44.0)
24	25	0.778	(19.8)	1.340	(34.0)	1.174	(29.8)	1.800	(45.7)

* For connector family identification details see Page 17, Section I. Consult factory for availability of other connector designators not shown above.

Table IV

Entry size	J		K		Cable range			
	max		max		min		max	
01	0.737	(18.7)	0.750	(19.1)	0.062	(1.6)	0.125	(3.2)
02	0.737	(18.7)	0.875	(22.2)	0.094	(2.4)	0.250	(6.4)
03	0.737	(18.7)	1.000	(25.4)	0.219	(5.6)	0.375	(9.5)
04	0.737	(18.7)	1.125	(28.6)	0.344	(8.7)	0.500	(12.7)
05	0.800	(20.3)	1.250	(31.8)	0.469	(11.9)	0.625	(15.9)
06	0.862	(21.9)	1.375	(34.9)	0.594	(15.1)	0.750	(19.1)
07	0.987	(25.1)	1.500	(38.1)	0.719	(18.3)	0.875	(22.2)
08	1.112	(28.2)	1.625	(41.3)	0.844	(21.4)	1.000	(25.4)
09	1.112	(28.2)	1.750	(44.5)	0.969	(24.6)	1.125	(28.6)
10	1.112	(28.2)	1.875	(47.6)	1.094	(27.8)	1.250	(31.8)

Notes

- Metric dimensions are shown in parentheses for reference only.
- Cable range is defined as the envelope area of the cable or wire bundle. It is not intended for inspection criteria.
- Consult factory when cable entry diameter exceeds Z diameter (see page 41).

Tolerance

Unless otherwise specified:
 .X ± .060 (1.5)
 .XX ± .030 (0.8)
 .XXX ± .015 (0.4)
 Angles ± 5 degrees

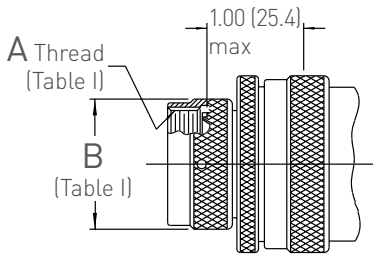
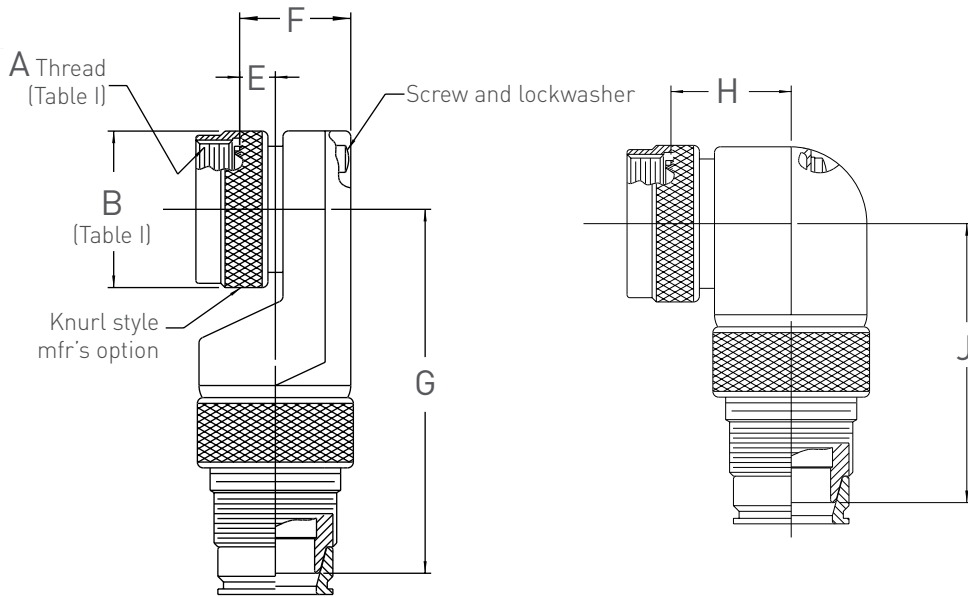

2-piece adapter

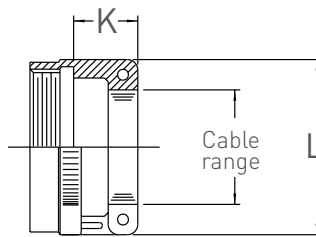

Style K
(Table IV)

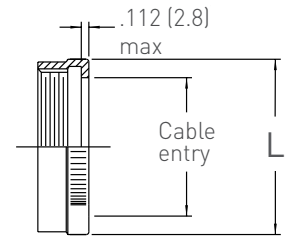

Style L
(Table IV)

Example part number

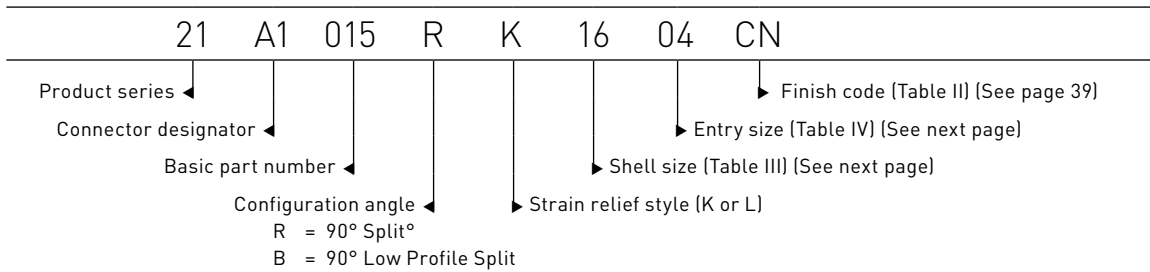

Table III

*Connector designator		E		F		G		H		J		Maximum entry size availability	
Shell size		max dimension		max dimension		max dimension		max dimension		max dimension		style B	style R
A1, F3, L1, X1	F4												
08	09	0.496	(12.6)	0.837	(21.3)	2.062	(52.4)	0.772	(19.6)	1.722	(43.7)	02	02
10	11	0.426	(10.8)	0.887	(22.5)	2.225	(56.5)	0.834	(21.2)	1.785	(45.3)	03	03
12	13	0.426	(10.8)	0.887	(22.5)	2.218	(56.3)	0.897	(22.8)	1.848	(46.9)	03	04
14	15	0.436	(11.1)	0.987	(25.1)	2.285	(58.0)	0.960	(24.4)	1.875	(47.6)	04	05
16	17	0.576	(14.6)	1.137	(28.9)	2.340	(59.4)	1.022	(26.0)	1.980	(50.3)	05	06
18	19	0.796	(20.2)	1.337	(34.0)	2.365	(60.1)	1.084	(27.5)	2.035	(51.7)	05	07
20	21	0.796	(20.2)	1.337	(34.0)	2.370	(60.2)	1.147	(29.1)	2.100	(53.3)	05	08
22	23	0.696	(17.7)	1.337	(34.0)	2.520	(64.0)	1.210	(30.7)	2.160	(54.9)	06	09
24	25	0.696	(17.7)	1.337	(34.0)	2.360	(59.9)	1.272	(32.3)	2.220	(56.4)	06	10

* For connector family identification details see Page 17, Section I. Consult factory for availability of other connector designators not shown above.

Table IV

Entry size	K max	L max	Cable range	
			min	max
01	0.737 (18.7)	0.750 (19.1)	0.062 (1.6)	0.125 (3.2)
02	0.737 (18.7)	0.875 (22.2)	0.094 (2.4)	0.250 (6.4)
03	0.737 (18.7)	1.000 (25.4)	0.219 (5.6)	0.375 (9.5)
04	0.737 (18.7)	1.125 (28.6)	0.344 (8.7)	0.500 (12.7)
05	0.800 (20.3)	1.250 (31.8)	0.469 (11.9)	0.625 (15.9)
06	0.862 (21.9)	1.375 (34.9)	0.594 (15.1)	0.750 (19.1)
07	0.987 (25.1)	1.500 (38.1)	0.719 (18.3)	0.875 (22.2)
08	1.112 (28.2)	1.625 (41.3)	0.844 (21.4)	1.000 (25.4)
09	1.112 (28.2)	1.750 (44.5)	0.969 (24.6)	1.125 (28.6)
10	1.112 (28.2)	1.875 (47.6)	1.094 (27.8)	1.250 (31.8)

Notes

- Metric dimensions are shown in parentheses for reference only.
- When maximum cable entry is exceeded, style 2 will be supplied.
- Cable range is defined as the envelope area of the cable or wire bundle. It is not intended for inspection criteria.

Tolerance

Unless otherwise specified:
 .X ± .060 (1.5)
 .XX ± .030 (0.8)
 .XXX ± .015 (0.4)
 Angles ± 5 degrees

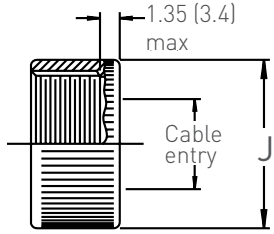
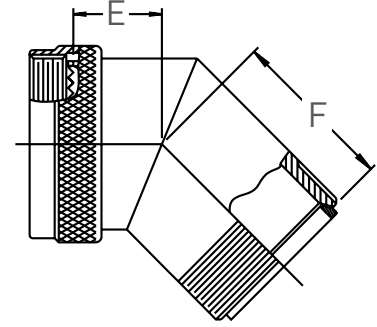
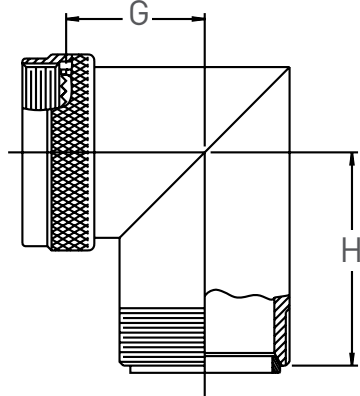
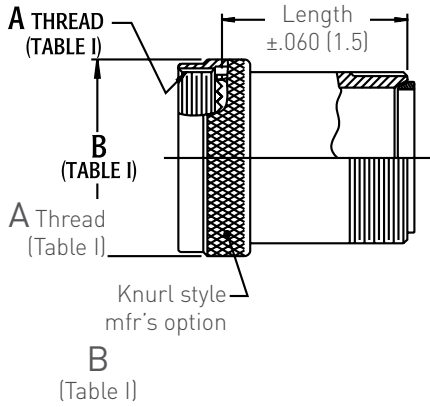

Style C
 (Table IV)

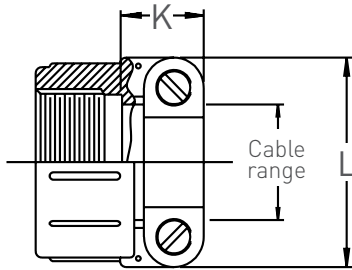

Style A
 (Table IV)

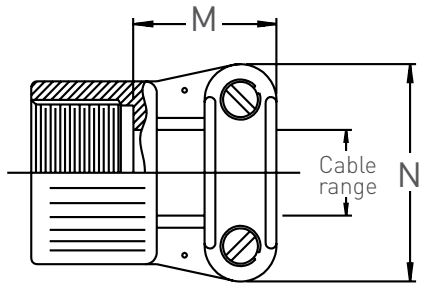

Style F
 (Table IV)

Example part number

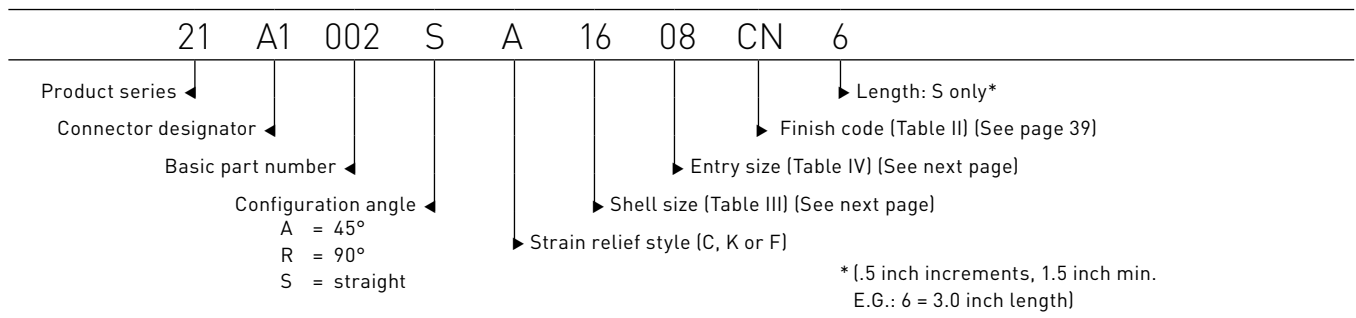

Table III

*Connector designator		E		F		G		H	
Shell size		max dimension		max dimension		max dimension		max dimension	
A1, F2, L1, X1	F4								
08	09	0.546	(13.9)	1.300	(33.0)	0.661	(16.8)	1.499	(38.1)
10	11	0.609	(15.5)	1.328	(33.7)	0.765	(19.4)	1.561	(39.6)
12	13	0.632	(16.1)	1.351	(34.3)	0.820	(20.8)	1.619	(41.1)
14	15	0.657	(16.7)	1.376	(35.0)	0.880	(22.4)	1.677	(42.6)
16	17	0.682	(17.3)	1.401	(35.6)	0.942	(23.9)	1.735	(44.1)
18	19	0.701	(17.8)	1.420	(36.1)	0.986	(25.0)	1.796	(45.6)
20	21	0.727	(18.5)	1.446	(36.7)	1.049	(26.6)	1.866	(47.4)
22	23	0.752	(19.1)	1.471	(37.4)	1.111	(28.2)	1.919	(48.7)
24	25	0.778	(19.8)	1.497	(38.0)	1.174	(29.8)	1.987	(50.5)

* For connector family identification details see Page 17, Section I. Consult factory for availability of other connector designators not shown above.

Table IV

Entry size	J		K		L		M		N		Cable range			
	max		max		max		max		max		min	max		
03	0.656	(16.7)	0.453	(11.5)	0.843	(21.4)	N/A		N/A		0.156	(4.0)	0.250	(6.4)
04	0.781	(19.8)	0.453	(11.5)	0.906	(23.0)	0.780	(19.8)	0.957	(24.3)	0.187	(4.7)	0.312	(7.9)
06	0.906	(23.0)	0.516	(13.1)	1.093	(27.8)	0.780	(19.8)	1.145	(29.1)	0.281	(7.1)	0.438	(11.1)
08	1.031	(26.2)	0.579	(14.7)	1.187	(30.1)	0.780	(19.8)	1.332	(33.8)	0.344	(8.7)	0.562	(14.3)
10	1.156	(29.4)	0.579	(14.7)	1.281	(32.5)	0.780	(19.8)	1.332	(33.8)	0.375	(9.5)	0.625	(15.9)
12	1.344	(34.1)	0.579	(14.7)	1.500	(38.1)	0.811	(20.6)	1.551	(39.4)	0.438	(11.1)	0.750	(19.1)
16	1.594	(40.5)	0.672	(17.1)	1.719	(43.7)	0.905	(23.0)	1.770	(45.0)	0.562	(14.3)	0.938	(23.8)
20	1.906	(48.4)	0.672	(17.1)	2.062	(52.4)	1.092	(27.7)	2.113	(53.7)	0.750	(19.1)	1.250	(31.8)
24	2.156	(54.8)	0.672	(17.1)	2.312	(58.7)	1.124	(28.5)	2.363	(60.0)	0.781	(19.8)	1.375	(34.9)
28	2.406	(61.1)	1.204	(30.6)	2.719	(69.1)	1.399	(35.5)	2.770	(70.4)	0.969	(24.6)	1.625	(41.3)

Notes

- Metric dimensions are shown in parentheses for reference only.
- Cable range is defined as the envelope area of the cable or wire bundle. It is not intended for inspection criteria.
- Consult factory when cable entry diameter exceeds Z diameter (see page 41).

Tolerance

Unless otherwise specified:
 .X ± .060 (1.5)
 .XX ± .030 (0.8)
 .XXX ± .015 (0.4)
 Angles ± 5 degrees

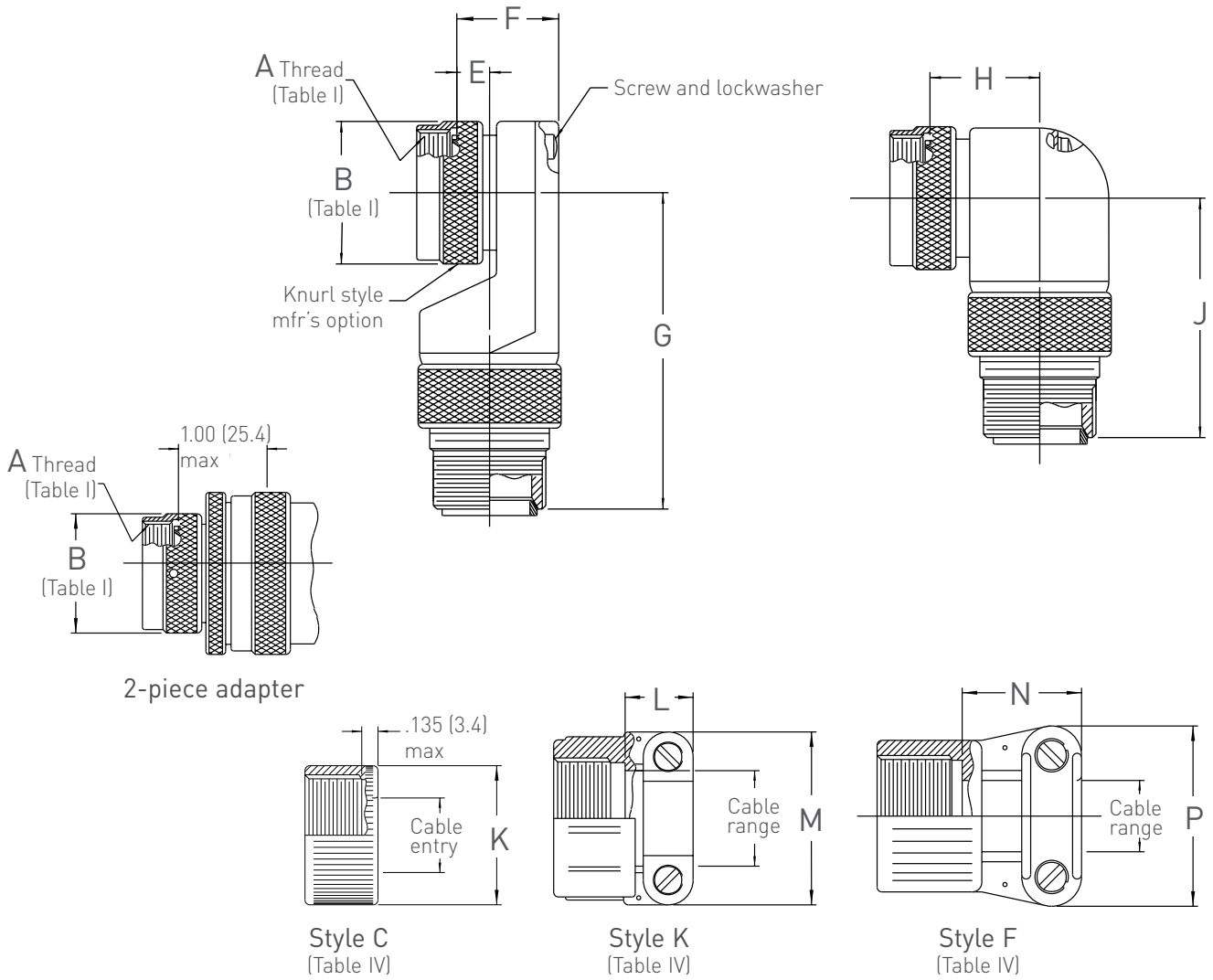

Example part number

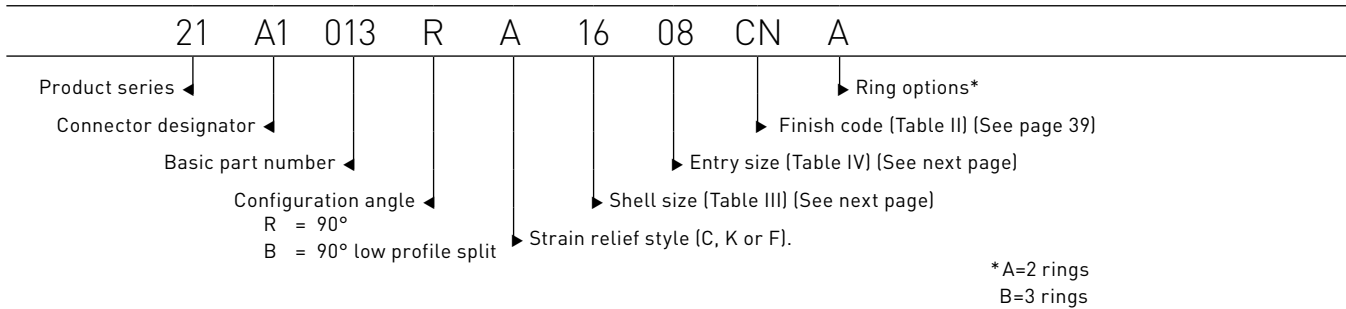

Table III

*Connector designator		E		F		G		H		J		Maximum entry size availability	
Shell size		max dimension		max dimension		max dimension		max dimension		max dimension		style B	style R
A1, F3, L1, X1	F4												
08	09	0.496	(12.6)	0.837	(21.3)	1.780	(45.2)	0.772	(19.6)	1.530	(38.9)	04	04
10	11	0.426	(10.8)	0.887	(22.5)	1.940	(49.3)	0.834	(21.2)	1.590	(40.4)	06	06
12	13	0.426	(10.8)	0.887	(22.5)	1.940	(49.3)	0.897	(22.8)	1.660	(42.2)	06	08
14	15	0.436	(11.1)	0.987	(25.1)	2.010	(51.1)	0.960	(24.4)	1.690	(42.9)	08	10
16	17	0.576	(14.6)	1.137	(28.9)	2.060	(52.3)	1.022	(26.0)	1.790	(45.5)	10	12
18	19	0.796	(20.2)	1.337	(34.0)	2.090	(53.1)	1.084	(27.5)	1.860	(47.2)	10	14
20	21	0.796	(20.2)	1.337	(34.0)	2.090	(53.1)	1.147	(29.1)	1.910	(48.5)	10	16
22	23	0.696	(17.7)	1.337	(34.0)	2.240	(56.9)	1.210	(30.7)	1.970	(50.0)	12	16
24	25	0.696	(17.7)	1.337	(34.0)	2.240	(56.9)	1.272	(32.3)	2.030	(51.6)	12	20

* For connector family identification details see Page 17, Section I. Consult factory for availability of other connector designators not shown above.

Table IV

Entry size	P		L		M		N		P		Cable range		
	max		max		max		max		max		min	max	
03	0.656	(16.7)	0.453	(11.5)	0.843	(21.4)	N/A		N/A		0.156	(4.0)	0.250 (6.4)
04	0.781	(19.8)	0.453	(11.5)	0.906	(23.0)	0.780	(19.8)	0.957	(24.3)	0.187	(4.7)	0.312 (7.9)
06	0.906	(23.0)	0.516	(13.1)	1.093	(27.8)	0.780	(19.8)	1.145	(29.1)	0.281	(7.1)	0.438 (11.1)
08	1.031	(26.2)	0.579	(14.7)	1.187	(30.1)	0.780	(19.8)	1.332	(33.8)	0.344	(8.7)	0.562 (14.3)
10	1.156	(29.4)	0.579	(14.7)	1.281	(32.5)	0.780	(19.8)	1.332	(33.8)	0.375	(9.5)	0.625 (15.9)
12	1.344	(34.1)	0.579	(14.7)	1.500	(38.1)	0.811	(20.6)	1.551	(39.4)	0.438	(11.1)	0.750 (19.1)
16	1.594	(40.5)	0.672	(17.1)	1.719	(43.7)	0.905	(23.0)	1.770	(45.0)	0.562	(14.3)	0.938 (23.8)
20	1.906	(48.4)	0.672	(17.1)	2.062	(52.4)	1.092	(27.7)	2.113	(53.7)	0.750	(19.1)	1.250 (31.8)

Notes

- 1 Metric dimensions are shown in parentheses for reference only.
- 2 When maximum cable entry is exceeded, style 2 will be supplied.
- 3 Cable range is defined as the envelope area of the cable or wire bundle. It is not intended for inspection criteria.

Tolerance

- Unless otherwise specified:
- .X ± .060 (1.5)
- .XX ± .030 (0.8)
- .XXX ± .015 (0.4)
- Angles ± 5 degrees

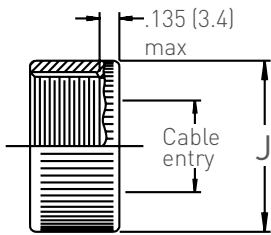
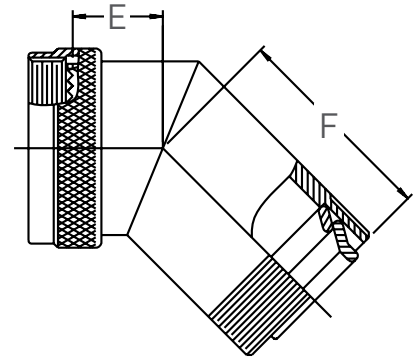
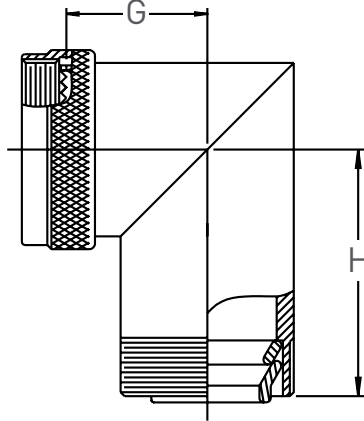
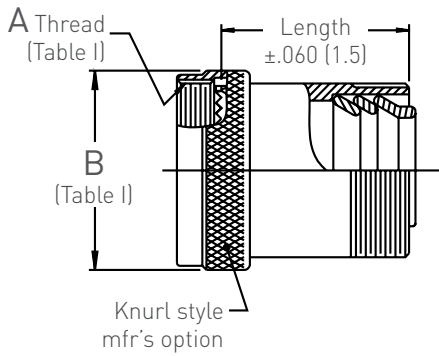

Style C
(Table IV)

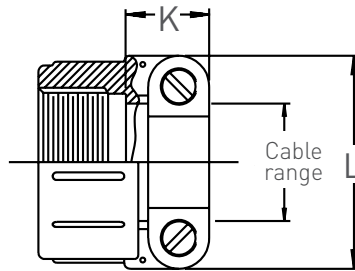

Style A
(Table IV)

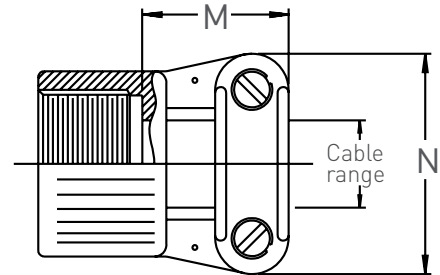

Style F
(Table IV)

Example part number

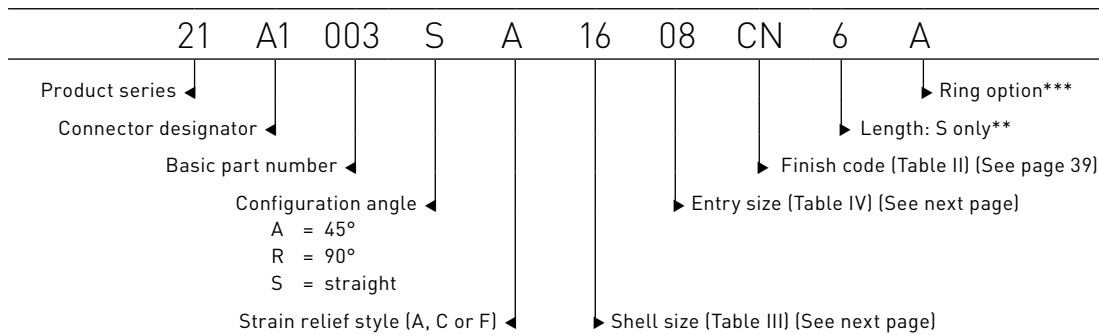

**[.5 inch increments, 1.5 inch min.
E.G.: 6 = 3.0 inch length]

***A = 2 rings
B = 3 rings

Table III

*Connector designator									
Shell size		E		F		G		H	
A1, F2, L1, X1	F4	max dimension		max dimension		max dimension		max dimension	
08	09	0.546	(13.9)	1.300	(33.0)	0.661	(16.8)	1.499	(38.1)
10	11	0.609	(15.5)	1.328	(33.7)	0.765	(19.4)	1.561	(39.6)
12	13	0.632	(16.1)	1.351	(34.3)	0.820	(20.8)	1.619	(41.1)
14	15	0.657	(16.7)	1.376	(35.0)	0.880	(22.4)	1.677	(42.6)
16	17	0.682	(17.3)	1.401	(35.6)	0.942	(23.9)	1.735	(44.1)
18	19	0.701	(17.8)	1.420	(36.1)	0.986	(25.0)	1.796	(45.6)
20	21	0.727	(18.5)	1.446	(36.7)	1.049	(26.6)	1.866	(47.4)
22	23	0.752	(19.1)	1.471	(37.4)	1.111	(28.2)	1.919	(48.7)
24	25	0.778	(19.8)	1.497	(38.0)	1.174	(29.8)	1.987	(50.5)

* For connector family identification details see Page 17, Section I. Consult factory for availability of other connector designators not shown above.

Table IV

Entry	J		K		L		M		N		Cable range			
size	max		max		max		max		max		min	max		
04	0.781	(19.8)	0.453	(11.5)	0.906	(23.0)	0.780	(19.8)	0.957	(24.3)	0.187	(4.7)	0.312	(7.9)
06	0.906	(23.0)	0.516	(13.1)	1.093	(27.8)	0.780	(19.8)	1.145	(29.1)	0.281	(7.1)	0.438	(11.1)
08	1.031	(26.2)	0.579	(14.7)	1.187	(30.1)	0.780	(19.8)	1.332	(33.8)	0.344	(8.7)	0.562	(14.3)
10	1.156	(29.4)	0.579	(14.7)	1.281	(32.5)	0.780	(19.8)	1.332	(33.8)	0.375	(9.5)	0.625	(15.9)
12	1.344	(34.1)	0.579	(14.7)	1.500	(38.1)	0.811	(20.6)	1.551	(39.4)	0.438	(11.1)	0.750	(19.1)
16	1.594	(40.5)	0.672	(17.1)	1.719	(43.7)	0.905	(23.0)	1.770	(45.0)	0.562	(14.3)	0.938	(23.8)
20	1.906	(48.4)	0.672	(17.1)	2.062	(52.4)	1.092	(27.7)	2.113	(53.7)	0.750	(19.1)	1.250	(31.8)
24	2.156	(54.8)	0.672	(17.1)	2.312	(58.7)	1.124	(28.5)	2.363	(60.0)	0.781	(19.8)	1.375	(34.9)

Notes

- 1 Metric dimensions are shown in parentheses for reference only.
- 2 Cable range is defined as the envelope area of the cable or wire bundle. It is not intended for inspection criteria.
- 3 Consult factory when cable entry diameter exceeds Z diameter (see page 41).

Tolerance

Unless otherwise specified:
 .X ± .060 (1.5)
 .XX ± .030 (0.8)
 .XXX ± .015 (0.4)
 Angles ± 5 degrees

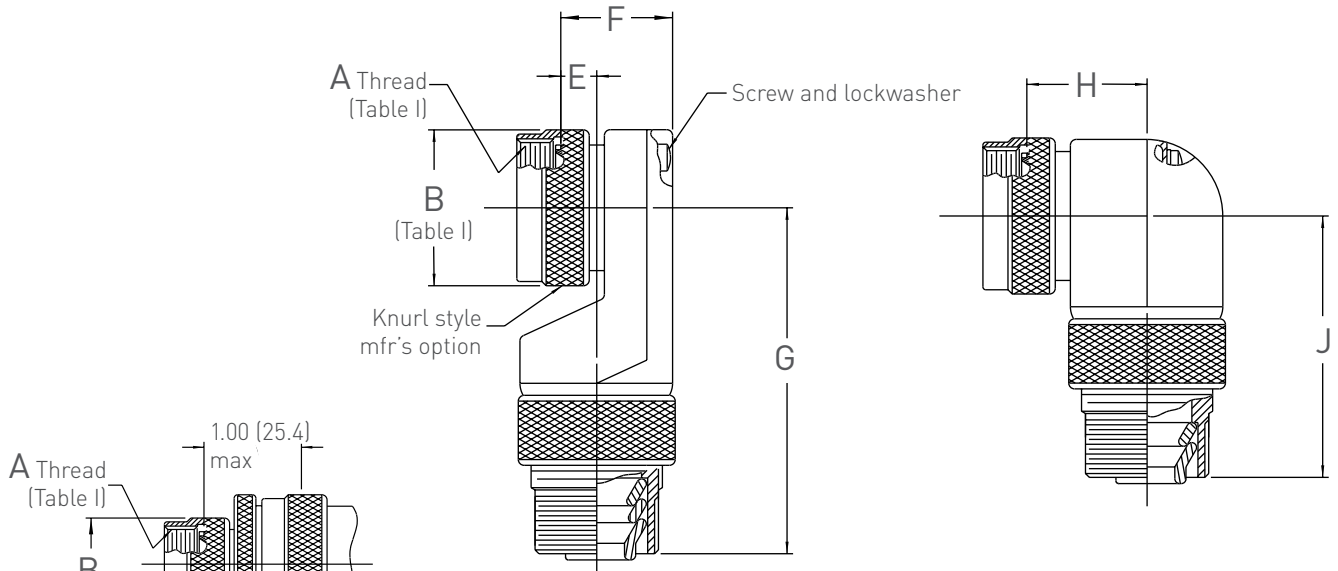

2-piece adapter

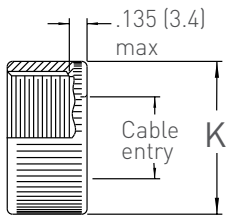

Style C
(Table IV)

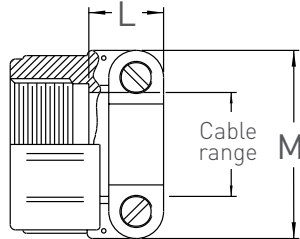

Style A
(Table IV)

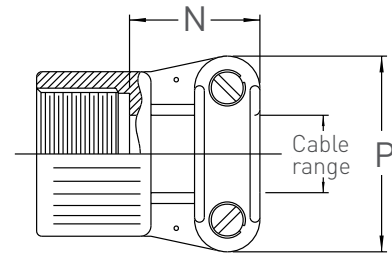

Style F
(Table IV)

Example part number

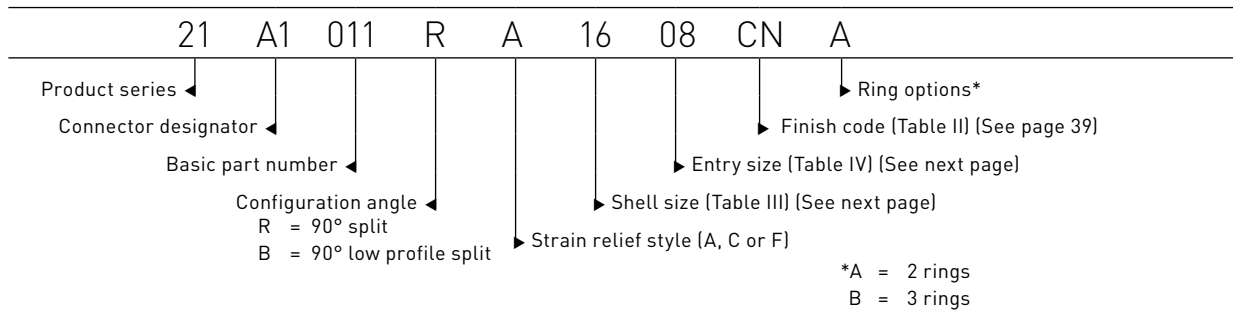

Table III

*Connector designator		E		F		G		H		J		Maximum entry size availability	
Shell size		max dimension		max dimension		max dimension		max dimension		max dimension		style B	style R
A1, F3, L1, X1	F4												
08	09	0.496	(12.6)	0.837	(21.3)	1.780	(45.2)	0.772	(19.6)	1.530	(38.9)	04	04
10	11	0.426	(10.8)	0.887	(22.5)	1.940	(49.3)	0.834	(21.2)	1.590	(40.4)	06	06
12	13	0.426	(10.8)	0.887	(22.5)	1.940	(49.3)	0.897	(22.8)	1.660	(42.2)	06	08
14	15	0.436	(11.1)	0.987	(25.1)	2.010	(51.1)	0.960	(24.4)	1.690	(42.9)	08	10
16	17	0.576	(14.6)	1.137	(28.9)	2.060	(52.3)	1.022	(26.0)	1.790	(45.5)	10	12
18	19	0.796	(20.2)	1.337	(34.0)	2.090	(53.1)	1.084	(27.5)	1.860	(47.2)	10	14
20	21	0.796	(20.2)	1.337	(34.0)	2.090	(53.1)	1.147	(29.1)	1.910	(48.5)	10	16
22	23	0.696	(17.7)	1.337	(34.0)	2.240	(56.9)	1.210	(30.7)	1.970	(50.0)	12	16
24	25	0.696	(17.7)	1.337	(34.0)	2.240	(56.9)	1.272	(32.3)	2.030	(51.6)	12	20

* For connector family identification details see Page 17, Section I. Consult factory for availability of other connector designators not shown above.

Table IV

Entry size	K max		L max		M max		N max		P max		Cable range		min max	
04	0.781	(19.8)	0.453	(11.5)	0.906	(23.0)	0.780	(19.8)	0.957	(24.3)	0.187	(4.7)	0.312	(7.9)
06	0.906	(23.0)	0.516	(13.1)	1.093	(27.8)	0.780	(19.8)	1.145	(29.1)	0.281	(7.1)	0.438	(11.1)
08	1.031	(26.2)	0.579	(14.7)	1.187	(30.1)	0.780	(19.8)	1.332	(33.8)	0.344	(8.7)	0.562	(14.3)
10	1.156	(29.4)	0.579	(14.7)	1.281	(32.5)	0.780	(19.8)	1.332	(33.8)	0.375	(9.5)	0.625	(15.9)
12	1.344	(34.1)	0.579	(14.7)	1.500	(38.1)	0.811	(20.6)	1.551	(39.4)	0.438	(11.1)	0.750	(19.1)
16	1.594	(40.5)	0.672	(17.1)	1.719	(43.7)	0.905	(23.0)	1.770	(45.0)	0.562	(14.3)	0.938	(23.8)
20	1.906	(48.4)	0.672	(17.1)	2.062	(52.4)	1.092	(27.7)	2.113	(53.7)	0.750	(19.1)	1.250	(31.8)

Notes

- 1 Metric dimensions are shown in parentheses for reference only.
- 2 When maximum cable entry is exceeded, style 2 will be supplied.
- 3 Cable range is defined as the envelope area of the cable or wire bundle. It is not intended for inspection criteria.

Tolerance

Unless otherwise specified:

.X ± .060 (1.5)

.XX ± .030 (0.8)

.XXX ± .015 (0.4)

Angles ± 5 degrees

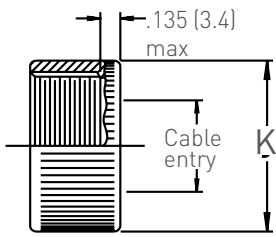
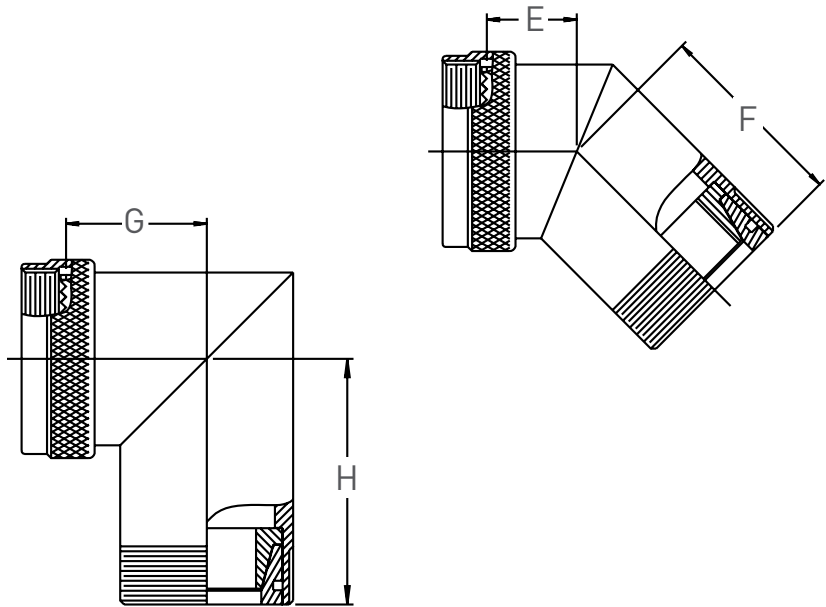
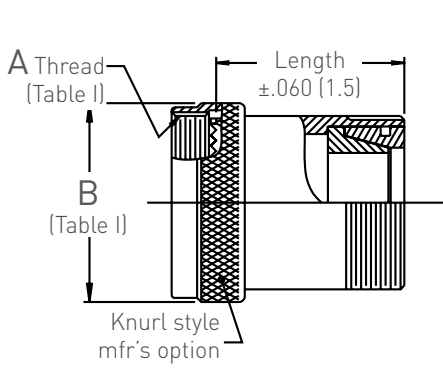

Style C (Table IV)

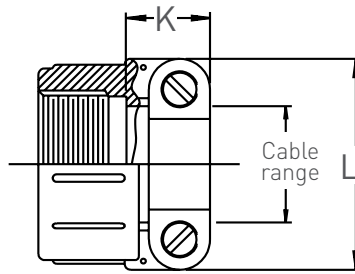

Style A (Table IV)

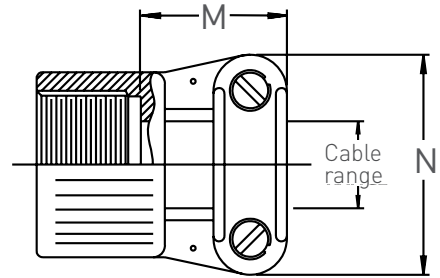

Style F (Table IV)

Example part number

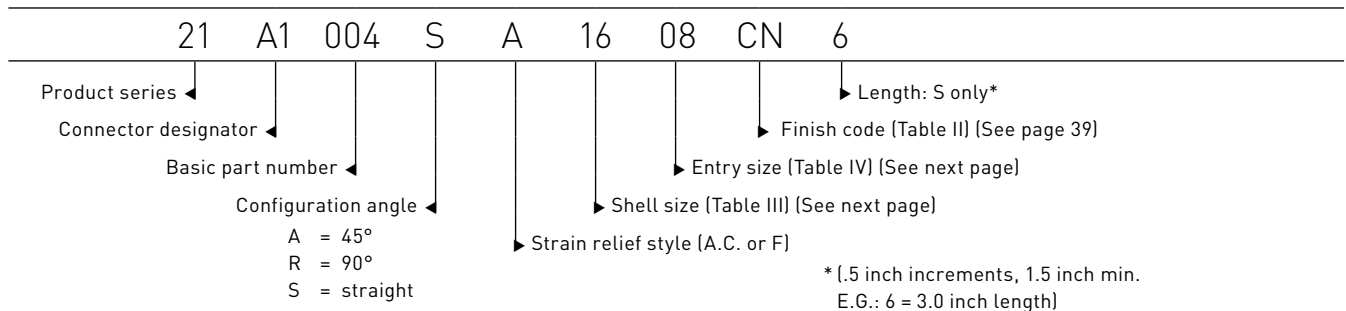

Table III

*Connector designator		E		F		G		H	
Shell size		max dimension		max dimension		max dimension		max dimension	
A1, F2, L1, X1	F4								
08	09	0.546	(13.9)	1.300	(33.0)	0.661	(16.8)	1.499	(38.1)
10	11	0.609	(15.5)	1.328	(33.7)	0.765	(19.4)	1.561	(39.6)
12	13	0.632	(16.1)	1.351	(34.3)	0.820	(20.8)	1.619	(41.1)
14	15	0.657	(16.7)	1.376	(35.0)	0.880	(22.4)	1.677	(42.6)
16	17	0.682	(17.3)	1.401	(35.6)	0.942	(23.9)	1.735	(44.1)
18	19	0.701	(17.8)	1.420	(36.1)	0.986	(25.0)	1.796	(45.6)
20	21	0.727	(18.5)	1.446	(36.7)	1.049	(26.6)	1.866	(47.4)
22	23	0.752	(19.1)	1.471	(37.4)	1.111	(28.2)	1.919	(48.7)
24	25	0.778	(19.8)	1.497	(38.0)	1.174	(29.8)	1.987	(50.5)

* For connector family identification details see Page 17, Section I. Consult factory for availability of other connector designators not shown above.

Table IV

Entry size	J		K		L		M		N		Cable range			
	max		max		max		max		max		min		max	
04	0.781	(19.8)	0.453	(11.5)	0.906	(23.0)	0.780	(19.8)	0.957	(24.3)	0.187	(4.7)	0.312	(7.9)
06	0.906	(23.0)	0.516	(13.1)	1.093	(27.8)	0.780	(19.8)	1.145	(29.1)	0.281	(7.1)	0.438	(11.1)
08	1.031	(26.2)	0.579	(14.7)	1.187	(30.1)	0.780	(19.8)	1.332	(33.8)	0.344	(8.7)	0.562	(14.3)
10	1.156	(29.4)	0.579	(14.7)	1.281	(32.5)	0.780	(19.8)	1.332	(33.8)	0.375	(9.5)	0.625	(15.9)
12	1.344	(34.1)	0.579	(14.7)	1.500	(38.1)	0.811	(20.6)	1.551	(39.4)	0.438	(11.1)	0.750	(19.1)
16	1.594	(40.5)	0.672	(17.1)	1.719	(43.7)	0.905	(23.0)	1.770	(45.0)	0.562	(14.3)	0.938	(23.8)
20	1.906	(48.4)	0.672	(17.1)	2.062	(52.4)	1.092	(27.7)	2.113	(53.7)	0.750	(19.1)	1.250	(31.8)
24	2.156	(54.8)	0.672	(17.1)	2.312	(58.7)	1.124	(28.5)	2.363	(60.0)	0.781	(19.8)	1.375	(34.9)
28	2.406	(61.1)	1.204	(30.6)	2.719	(69.1)	1.399	(35.5)	2.770	(70.4)	0.969	(24.6)	1.625	(41.3)
32	2.656	(67.5)	1.204	(30.6)	2.969	(75.4)	1.399	(35.5)	3.020	(76.7)	1.125	(28.6)	1.875	(47.6)
40	3.156	(80.2)	1.141	(29.0)	3.531	(89.7)	N/A		N/A		1.469	(37.3)	2.375	(60.3)

Notes

- 1 Metric dimensions are shown in parentheses for reference only.
- 2 Cable range is defined as the envelope area of the cable or wire bundle. It is not intended for inspection criteria.
- 3 Consult factory when cable entry diameter exceeds Z diameter (see page 41).

Tolerance

Unless otherwise specified:
 .X ± .060 (1.5)
 .XX ± .030 (0.8)
 .XXX ± .015 (0.4)
 Angles ± 5 degrees

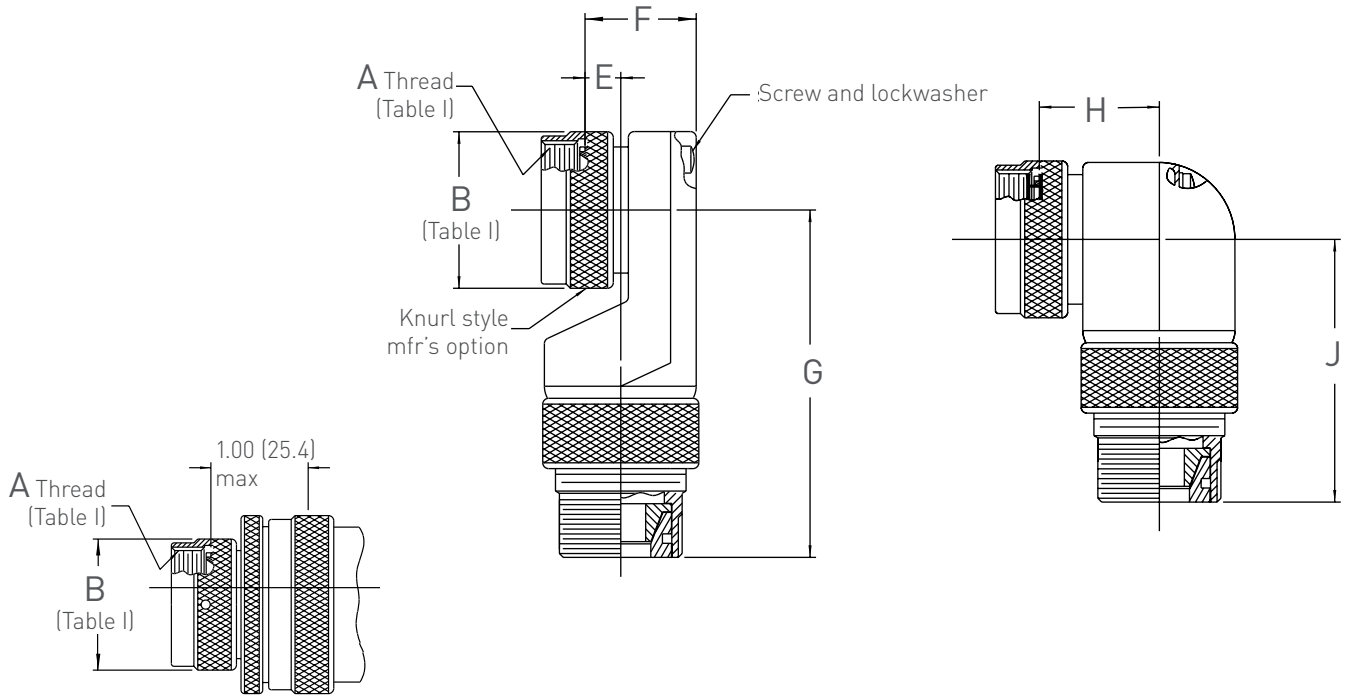

2-piece adapter

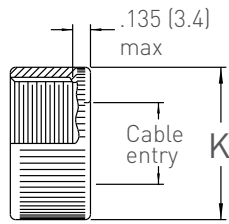

Style C
(Table IV)

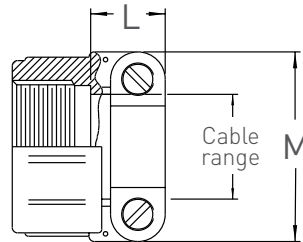

Style A
(Table IV)

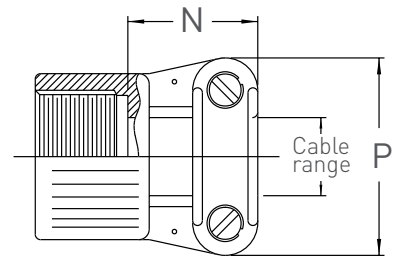

Style F
(Table IV)

Example part number

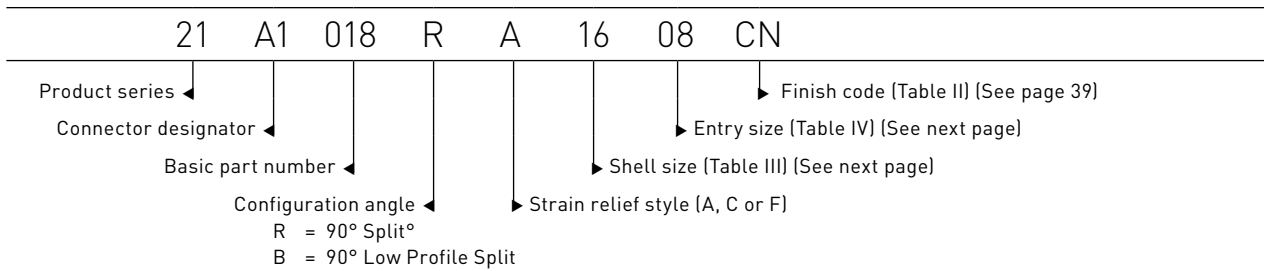

Table III

*Connector designator		E		F		G		H		J		Maximum entry size availability	
Shell size		max dimension		max dimension		max dimension		max dimension		max dimension		style B	style R
A1, F3, L1, X1	F4												
08	09	0.496	(12.6)	0.837	(21.3)	1.780	(45.2)	0.772	(19.6)	1.530	(38.9)	04	04
10	11	0.426	(10.8)	0.887	(22.5)	1.940	(49.3)	0.834	(21.2)	1.590	(40.4)	06	06
12	13	0.426	(10.8)	0.887	(22.5)	1.940	(49.3)	0.897	(22.8)	1.660	(42.2)	06	08
14	15	0.436	(11.1)	0.987	(25.1)	2.010	(51.1)	0.960	(24.4)	1.690	(42.9)	08	10
16	17	0.576	(14.6)	1.137	(28.9)	2.060	(52.3)	1.022	(26.0)	1.790	(45.5)	10	12
18	19	0.796	(20.2)	1.337	(34.0)	2.090	(53.1)	1.084	(27.5)	1.860	(47.2)	10	14
20	21	0.796	(20.2)	1.337	(34.0)	2.090	(53.1)	1.147	(29.1)	1.910	(48.5)	10	16
22	23	0.696	(17.7)	1.337	(34.0)	2.240	(56.9)	1.210	(30.7)	1.970	(50.0)	12	16
24	25	0.696	(17.7)	1.337	(34.0)	2.240	(56.9)	1.272	(32.3)	2.030	(51.6)	12	20

* For connector family identification details see Page 17, Section I. Consult factory for availability of other connector designators not shown above.

Table IV

Entry size	K max		L max		M max		N max		P max		Cable range		min max	
04	0.781	(19.8)	0.453	(11.5)	0.906	(23.0)	0.780	(19.8)	0.957	(24.3)	0.187	(4.7)	0.312	(7.9)
06	0.906	(23.0)	0.516	(13.1)	1.093	(27.8)	0.780	(19.8)	1.145	(29.1)	0.281	(7.1)	0.438	(11.1)
08	1.031	(26.2)	0.579	(14.7)	1.187	(30.1)	0.780	(19.8)	1.332	(33.8)	0.344	(8.7)	0.562	(14.3)
10	1.156	(29.4)	0.579	(14.7)	1.281	(32.5)	0.780	(19.8)	1.332	(33.8)	0.375	(9.5)	0.625	(15.9)
12	1.344	(34.1)	0.579	(14.7)	1.500	(38.1)	0.811	(20.6)	1.551	(39.4)	0.438	(11.1)	0.750	(19.1)
16	1.594	(40.5)	0.672	(17.1)	1.719	(43.7)	0.905	(23.0)	1.770	(45.0)	0.562	(14.3)	0.938	(23.8)
20	1.906	(48.4)	0.672	(17.1)	2.062	(52.4)	1.092	(27.7)	2.113	(53.7)	0.750	(19.1)	1.250	(31.8)

Notes

- 1 Metric dimensions are shown in parentheses for reference only.
- 2 When maximum cable entry is exceeded, style 2 will be supplied.
- 3 Cable range is defined as the envelope area of the cable or wire bundle. It is not intended for inspection criteria.

Tolerance

Unless otherwise specified:

.X ± .060 (1.5)

.XX ± .030 (0.8)

.XXX ± .015 (0.4)

Angles ± 5 degrees

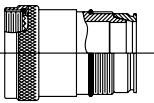
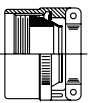
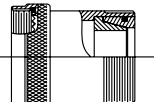
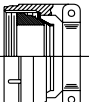
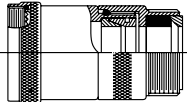
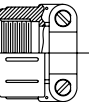
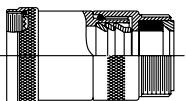
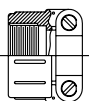
Basic part designator	Product page	Configuration description		
001	129	RFI and environmental adapters with the self-seating spin coupling feature, light weight, external cone/ring termination and strain relief in straight and angled configurations for overall or individual shield terminating.		
002	131	RFI and environmental adapters with dual recessed termination rings and the self-seating coupling ring with or without strain relief for overall shield termination in straight and angled configurations.		
003	133	RFI and environmental adapters with dual recessed termination rings and the self-seating coupling ring with or without strain relief for overall shield termination in straight and angled configurations for medium and heavy duty applications.		
004	135	RFI adapters utilizing two or three ring termination for overall and/or individual shield termination, self-seating spin coupling, environmental with or without strain relief in straight and angled configurations.		

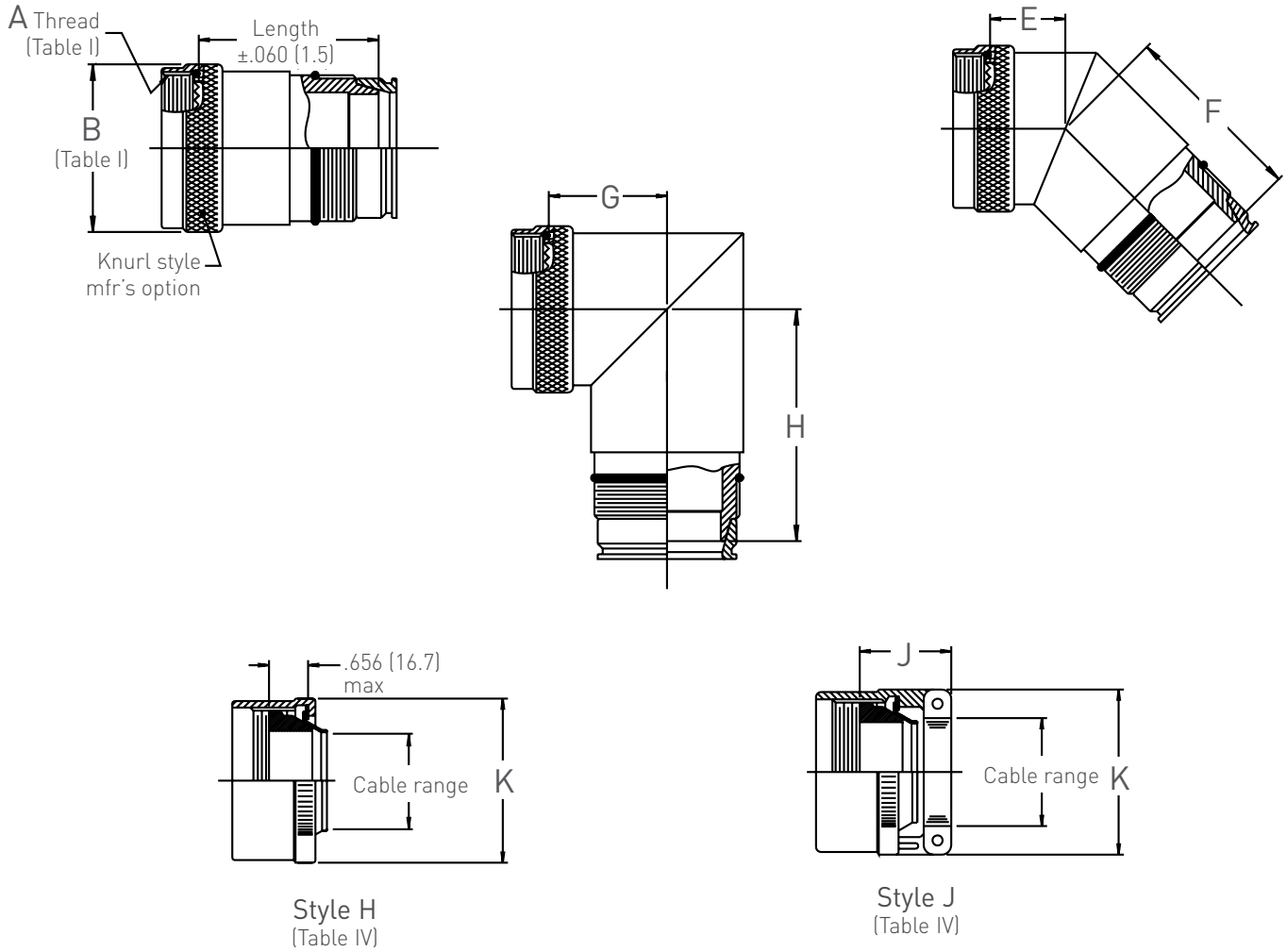

Example part number

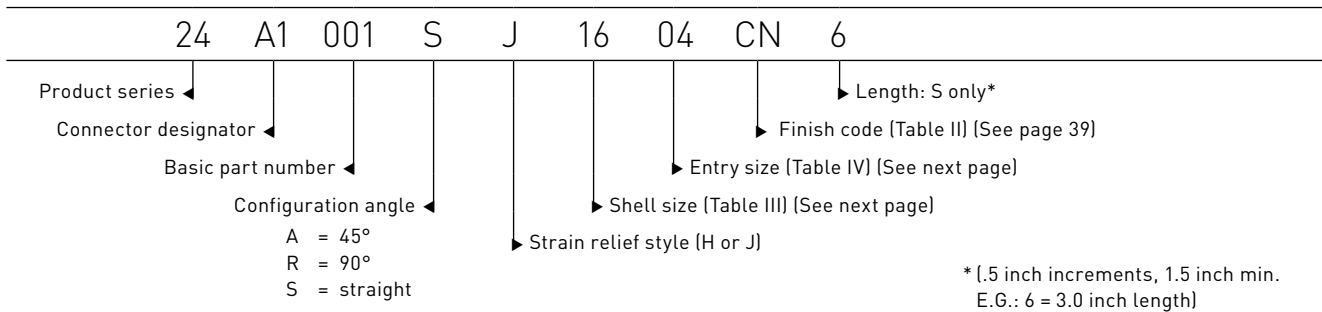

Table III

*Connector designator									
Shell size		E		F		G		H	
A1, F2, L1, X2	F5	max dimension		max dimension		max dimension		max dimension	
08	09	0.612	(15.5)	1.424	(36.2)	0.727	(18.5)	1.655	(42.0)
10	11	0.675	(17.1)	1.452	(36.9)	0.831	(21.1)	1.711	(43.5)
12	13	0.698	(17.7)	1.475	(37.5)	0.886	(22.5)	1.767	(44.9)
14	15	0.723	(18.4)	1.500	(38.1)	0.946	(24.0)	1.833	(46.6)
16	17	0.748	(19.0)	1.525	(38.7)	1.008	(25.6)	1.891	(48.0)
18	19	0.767	(19.5)	1.544	(39.2)	1.052	(26.7)	1.952	(49.6)
20	21	0.793	(20.1)	1.570	(39.9)	1.115	(28.3)	2.022	(51.4)
22	23	0.818	(20.8)	1.595	(40.5)	1.177	(29.9)	2.075	(52.7)
24	25	0.844	(21.4)	1.621	(41.2)	1.240	(31.5)	2.143	(54.4)

* For connector family identification details see Page 17, Section I. Consult factory for availability of other connector designators not shown above.

Table IV

Entry size	J		K		Cable range			
	max		max		min	max		
01	1.250	(31.8)	0.750	(19.1)	0.062	(1.6)	0.125	(3.2)
02	1.250	(31.8)	0.875	(22.2)	0.094	(2.4)	0.250	(6.4)
03	1.250	(31.8)	1.000	(25.4)	0.219	(5.6)	0.375	(9.5)
04	1.250	(31.8)	1.125	(28.6)	0.344	(8.7)	0.500	(12.7)
05	1.312	(33.3)	1.250	(31.8)	0.469	(11.9)	0.625	(15.9)
06	1.375	(34.9)	1.375	(34.9)	0.594	(15.1)	0.750	(19.1)
07	1.500	(38.1)	1.500	(38.1)	0.719	(18.3)	0.875	(22.2)
08	1.625	(41.3)	1.625	(41.3)	0.844	(21.4)	1.000	(25.4)
09	1.625	(41.3)	1.750	(44.5)	0.969	(24.6)	1.125	(28.6)
10	1.625	(41.3)	1.875	(47.6)	1.094	(27.8)	1.250	(31.8)

Notes

- Metric dimensions are shown in parentheses for reference only.
- O-ring not supplied on connector designators A1 and L1. F2 is moisture proof only.
- Cable range is defined as the envelope area of the cable or wire bundle. It is not intended for inspection criteria.
- Consult factory when cable entry diameter exceeds Z diameter (see page 41).

Tolerance

Unless otherwise specified:

- .X ± .060 (1.5)
- .XX ± .030 (0.8)
- .XXX ± .015 (0.4)
- Angles ± 5 degrees

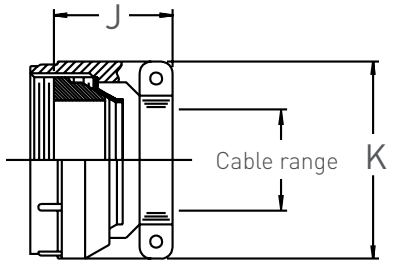
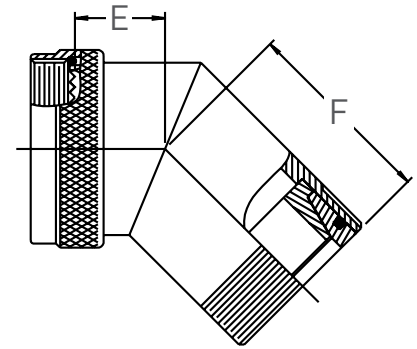
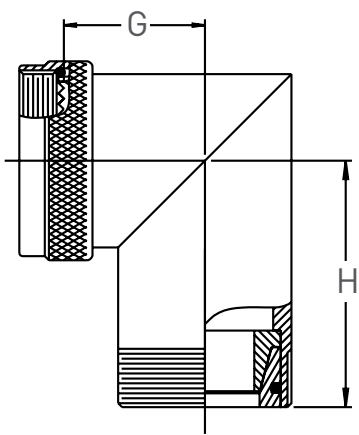
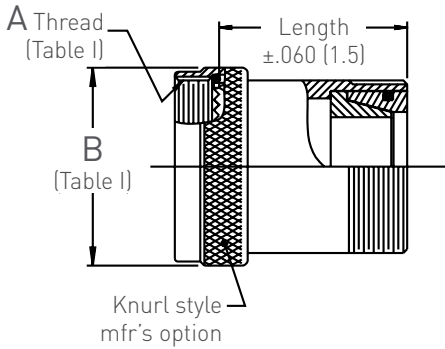

Style E
(Table IV)

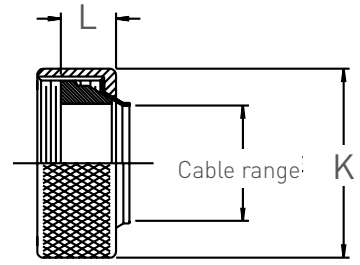

Style G
(Table IV)

Example part number

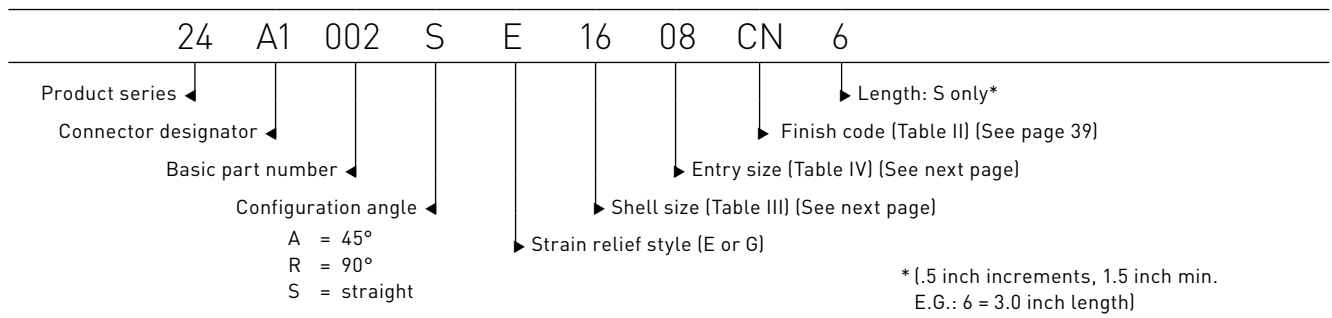

Table III

*Connector designator									
Shell size		E		F		G		H	
A1, F2, L1, X2	F5	max dimension		max dimension		max dimension		max dimension	
08	09	0.612	(15.5)	1.300	(33.0)	0.727	(18.5)	1.499	(38.1)
10	11	0.675	(17.1)	1.328	(33.7)	0.831	(21.1)	1.561	(39.6)
12	13	0.698	(17.7)	1.351	(34.3)	0.886	(22.5)	1.619	(41.1)
14	15	0.723	(18.4)	1.376	(35.0)	0.946	(24.0)	1.677	(42.6)
16	17	0.748	(19.0)	1.401	(35.6)	1.008	(25.6)	1.735	(44.1)
18	19	0.767	(19.5)	1.420	(36.1)	1.052	(26.7)	1.796	(45.6)
20	21	0.793	(20.1)	1.446	(36.7)	1.115	(28.3)	1.866	(47.4)
22	23	0.818	(20.8)	1.471	(37.4)	1.177	(29.9)	1.919	(48.7)
24	25	0.844	(21.4)	1.497	(38.0)	1.240	(31.5)	1.987	(50.5)

* For connector family identification details see Page 17, Section I. Consult factory for availability of other connector designators not shown above.

Table IV

Entry size	J		K		L		Cable range			
	max		max		max		min	max		
04	1.219	(31.0)	0.937	(23.8)	0.578	(14.7)	0.188	(4.8)	0.312	(7.9)
06	1.219	(31.0)	1.062	(27.0)	0.578	(14.7)	0.250	(6.4)	0.438	(11.1)
08	1.219	(31.0)	1.188	(30.2)	0.578	(14.7)	0.312	(7.9)	0.531	(13.5)
10	1.281	(32.5)	1.312	(33.3)	0.594	(15.1)	0.375	(9.5)	0.625	(15.9)
12	1.281	(32.5)	1.562	(39.7)	0.656	(16.7)	0.500	(12.7)	0.750	(19.1)
16	1.406	(35.7)	1.750	(44.5)	0.656	(16.7)	0.700	(17.8)	0.938	(23.8)
20	1.656	(42.1)	2.250	(57.2)	0.734	(18.6)	0.926	(23.5)	1.250	(31.8)
24	1.906	(48.4)	2.375	(60.3)	0.953	(24.2)	1.125	(28.6)	1.375	(34.9)
28	1.906	(48.4)	2.625	(66.7)	0.953	(24.2)	1.312	(33.3)	1.625	(41.3)
32	2.000	(50.8)	2.812	(71.4)	1.093	(27.8)	1.500	(38.1)	1.875	(47.6)

Notes

- 1 Metric dimensions are shown in parentheses for reference only.**
- 2 O-ring not supplied on connector designators A1 and L1. F2 is moisture proof only.**
- 3 Cable range is defined as the envelope area of the cable or wire bundle. It is not intended for inspection criteria.**
- 4 Consult factory when cable entry diameter exceeds Z diameter (see page 41).**

Tolerance

Unless otherwise specified:
 .X ± .060 (1.5)
 .XX ± .030 (0.8)
 .XXX ± .015 (0.4)
 Angles ± 5 degrees

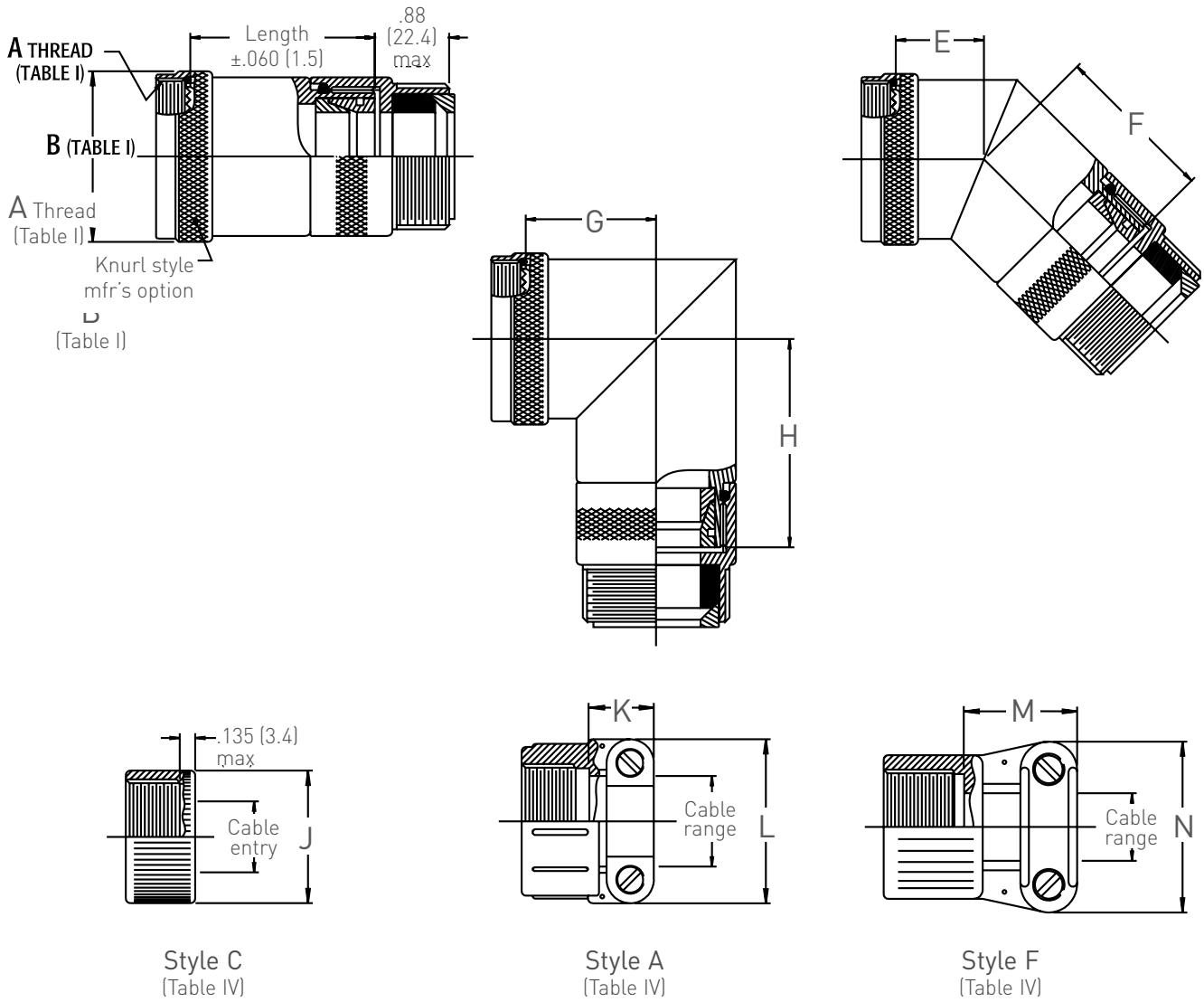

Example part number

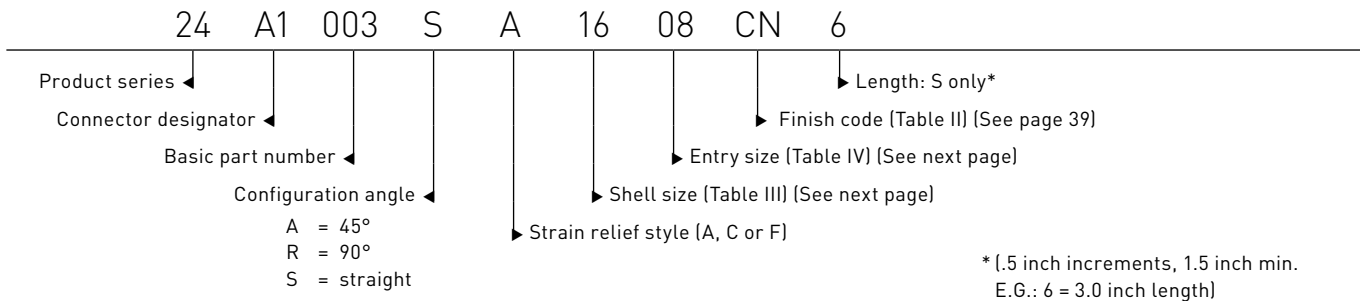

Table III

*Connector designator		E		F		G		H	
Shell size		max dimension		max dimension		max dimension		max dimension	
A1, F2, L1, X2	F5								
08	09	0.612	(15.5)	1.487	(37.8)	0.727	(18.5)	1.686	(42.8)
10	11	0.675	(17.1)	1.151	(29.2)	0.831	(21.1)	1.742	(44.2)
12	13	0.698	(17.7)	1.538	(39.1)	0.886	(22.5)	1.798	(45.7)
14	15	0.723	(18.4)	1.563	(39.7)	0.946	(24.0)	1.864	(47.3)
16	17	0.748	(19.0)	1.607	(40.8)	1.008	(25.6)	1.922	(48.8)
18	19	0.767	(19.5)	1.633	(41.5)	1.052	(26.7)	1.983	(50.4)
20	21	0.793	(20.1)	1.658	(42.1)	1.115	(28.3)	2.053	(52.1)
22	23	0.818	(20.8)	1.684	(42.8)	1.177	(29.9)	2.106	(53.5)
24	25	0.844	(21.4)	1.497	(38.0)	1.240	(31.5)	2.174	(55.2)

* For connector family identification details see Page 17, Section I. Consult factory for availability of other connector designators not shown above.

Table IV

Entry	J		K		L		M		N		Cable range			
size	max		max		max		max		max		min	max		
04	0.781	(19.8)	0.453	(11.5)	0.906	(23.0)	0.780	(19.8)	0.957	(24.3)	0.187	(4.7)	0.312	(7.9)
06	0.906	(23.0)	0.516	(13.1)	1.093	(27.8)	0.780	(19.8)	1.145	(29.1)	0.281	(7.1)	0.438	(11.1)
08	1.031	(26.2)	0.579	(14.7)	1.187	(30.1)	0.780	(19.8)	1.332	(33.8)	0.344	(8.7)	0.562	(14.3)
10	1.156	(29.4)	0.579	(14.7)	1.281	(32.5)	0.780	(19.8)	1.332	(33.8)	0.375	(9.5)	0.625	(15.9)
12	1.344	(34.1)	0.579	(14.7)	1.500	(38.1)	0.811	(20.6)	1.551	(39.4)	0.438	(11.1)	0.750	(19.1)
16	1.594	(40.5)	0.672	(17.1)	1.719	(43.7)	0.905	(23.0)	1.770	(45.0)	0.562	(14.3)	0.938	(23.8)
20	1.906	(48.4)	0.672	(17.1)	2.062	(52.4)	1.092	(27.7)	2.113	(53.7)	0.750	(19.1)	1.250	(31.8)
24	2.156	(54.8)	0.672	(17.1)	2.312	(58.7)	1.124	(28.5)	2.363	(60.0)	0.781	(19.8)	1.375	(34.9)
28	2.406	(61.1)	1.204	(30.6)	2.719	(69.1)	1.399	(35.5)	2.770	(70.4)	0.969	(24.6)	1.625	(41.3)
32	2.656	(67.5)	1.204	(30.6)	2.969	(75.4)	1.399	(35.5)	3.020	(76.7)	1.125	(28.6)	1.875	(47.6)
40	3.156	(80.2)	1.141	(29.0)	3.531	(89.7)	N/A		N/A		1.469	(37.3)	2.375	(60.3)

Notes

- Metric dimensions are shown in parentheses for reference only.
- O-ring not supplied on connector designators A1 and L1. F2 is moisture proof only.
- Cable range is defined as the envelope area of the cable or wire bundle. It is not intended for inspection criteria.
- Consult factory when cable entry diameter exceeds Z diameter (see page 41).

Tolerance

Unless otherwise specified:

- .X ± .060 (1.5)
- .XX ± .030 (0.8)
- .XXX ± .015 (0.4)
- Angles ± 5 degrees

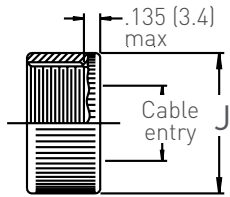
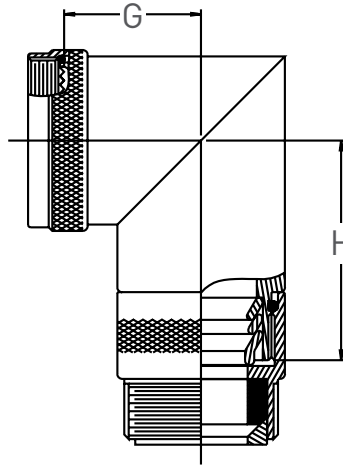
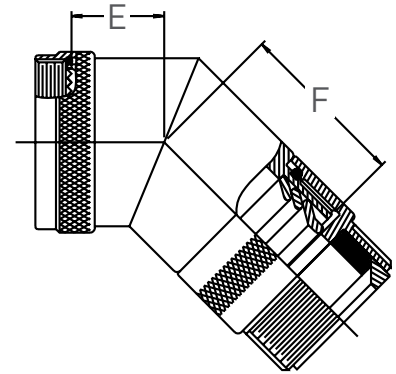
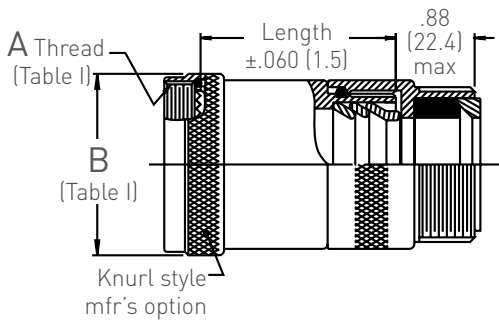

Style C
(Table IV)

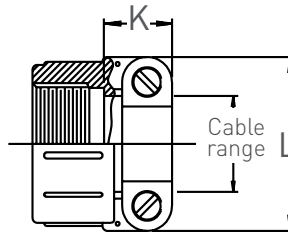

Style A
(Table IV)

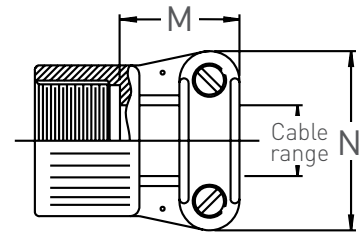

Style F
(Table IV)

Example part number

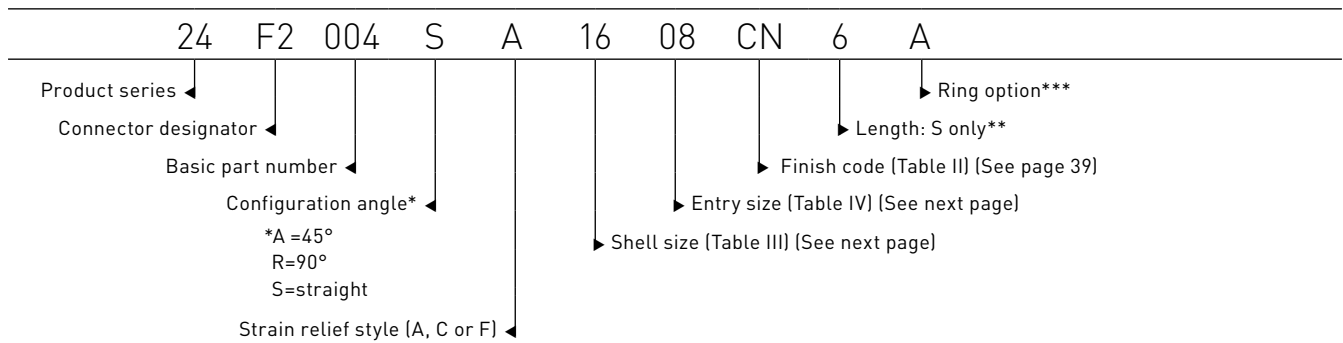

*** A = 2 rings
B = 3 rings

** [.5 inch increments, 1.5 inch min.
E.G.: 6 = 3.0 inch length]

Table III

*Connector designator									
Shell size		E		F		G		H	
A1, F2, L1, X2	F5	max dimension		max dimension		max dimension		max dimension	
08	09	0.612	(15.5)	1.487	(37.8)	0.727	(18.5)	1.686	(42.8)
10	11	0.675	(17.1)	1.151	(29.2)	0.831	(21.1)	1.742	(44.2)
12	13	0.698	(17.7)	1.538	(39.1)	0.886	(22.5)	1.798	(45.7)
14	15	0.723	(18.4)	1.563	(39.7)	0.946	(24.0)	1.864	(47.3)
16	17	0.748	(19.0)	1.607	(40.8)	1.008	(25.6)	1.922	(48.8)
18	19	0.767	(19.5)	1.633	(41.5)	1.052	(26.7)	1.983	(50.4)
20	21	0.793	(20.1)	1.658	(42.1)	1.115	(28.3)	2.053	(52.1)
22	23	0.818	(20.8)	1.684	(42.8)	1.177	(29.9)	2.106	(53.5)
24	25	0.844	(21.4)	1.497	(38.0)	1.240	(31.5)	2.174	(55.2)

* For connector family identification details see Page 17, Section I. Consult factory for availability of other connector designators not shown above.

Table IV

Entry	J	K	L	M	N	Cable range								
size	max	max	max	max	max	min	max							
04	0.781	(19.8)	0.453	(11.5)	0.906	(23.0)	0.780	(19.8)	0.957	(24.3)	0.187	(4.7)	0.312	(7.9)
06	0.906	(23.0)	0.516	(13.1)	1.093	(27.8)	0.780	(19.8)	1.145	(29.1)	0.281	(7.1)	0.438	(11.1)
08	1.031	(26.2)	0.579	(14.7)	1.187	(30.1)	0.780	(19.8)	1.332	(33.8)	0.344	(8.7)	0.562	(14.3)
10	1.156	(29.4)	0.579	(14.7)	1.281	(32.5)	0.780	(19.8)	1.332	(33.8)	0.375	(9.5)	0.625	(15.9)
12	1.344	(34.1)	0.579	(14.7)	1.500	(38.1)	0.811	(20.6)	1.551	(39.4)	0.438	(11.1)	0.750	(19.1)
16	1.594	(40.5)	0.672	(17.1)	1.719	(43.7)	0.905	(23.0)	1.770	(45.0)	0.562	(14.3)	0.938	(23.8)
20	1.906	(48.4)	0.672	(17.1)	2.062	(52.4)	1.092	(27.7)	2.113	(53.7)	0.750	(19.1)	1.250	(31.8)
24	2.156	(54.8)	0.672	(17.1)	2.312	(58.7)	1.124	(28.5)	2.363	(60.0)	0.781	(19.8)	1.375	(34.9)

Notes

- Metric dimensions are shown in parentheses for reference only.
- O-ring not supplied on connector designators A1 and L1. F2 is moisture proof only.
- Cable range is defined as the envelope area of the cable or wire bundle. It is not intended for inspection criteria.
- Consult factory when cable entry diameter exceeds Z diameter (see page 41).

Tolerance

- Unless otherwise specified:
- .X ± .060 (1.5)
 - .XX ± .030 (0.8)
 - .XXX ± .015 (0.4)
 - Angles ± 5 degrees

Basic part designator	Product page	Configuration description
001	139	EMI/RFI adapters with self-seating spin coupling nut capability.
003	141	Environmental option with and without strain relief for overall or individual shield termination and utilizes an iris spring for terminating in straight and angled configurations.

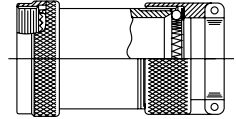

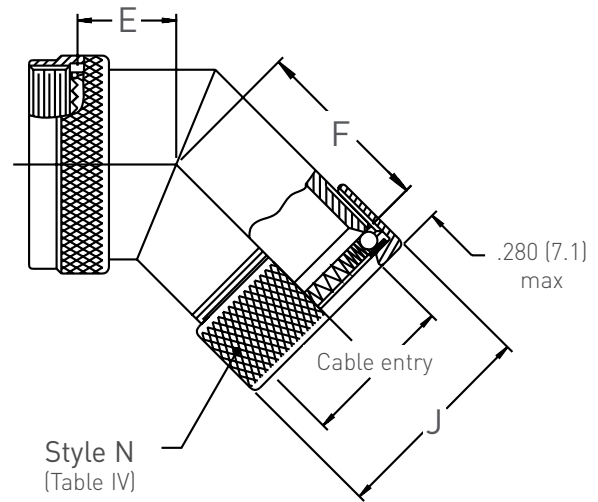
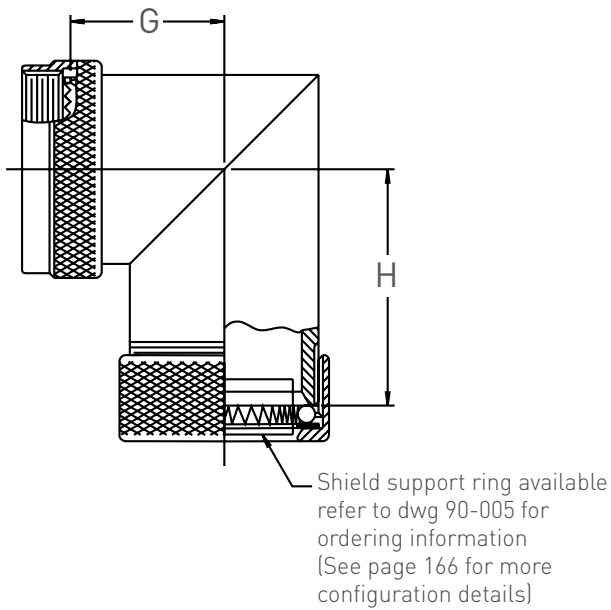
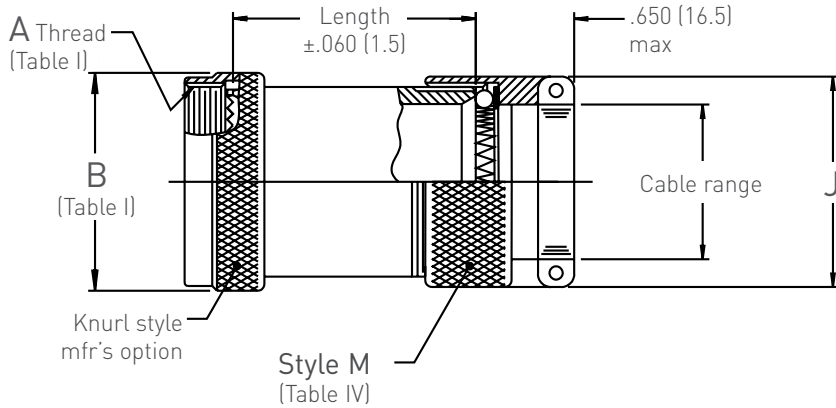

Example part number

33	F3	001	S	M	16	04	CN	6
Product series	Connector designator	Basic part number	Configuration angle	Strain relief style (M or N)	Shell size (Table III) (See next page)	Entry size (Table IV) (See next page)	Finish code (Table II) (See page 39)	Length: S only*
		A = 45° R = 90° S = straight						* [.5 inch increments, 1.5 inch min. E.G.: 6 = 3.0 inch length]

Table III

*Connector designator									
Shell size		E		F		G		H	
A1, F3, L1, X1	F4	max dimension		max dimension		max dimension		max dimension	
08	09	0.546	(13.9)	0.924	(23.5)	0.661	(16.8)	1.000	(25.4)
10	11	0.609	(15.5)	0.952	(24.2)	0.765	(19.4)	1.055	(26.8)
12	13	0.632	(16.1)	0.975	(24.8)	0.820	(20.8)	1.111	(28.2)
14	15	0.657	(16.7)	1.000	(25.4)	0.880	(22.4)	1.177	(29.9)
16	17	0.682	(17.3)	1.025	(26.0)	0.942	(23.9)	1.235	(31.4)
18	19	0.701	(17.8)	1.044	(26.5)	0.986	(25.0)	1.296	(32.9)
20	21	0.727	(18.5)	1.070	(27.2)	1.049	(26.6)	1.366	(34.7)
22	23	0.752	(19.1)	1.095	(27.8)	1.111	(28.2)	1.419	(36.0)
24	25	0.778	(19.8)	1.121	(28.5)	1.174	(29.8)	1.487	(37.8)

* For connector family identification details see Page 17, Section I. Consult factory for availability of other connector designators not shown above.

apv

Entry size	J		Cable range			
	max		min	max		
02	0.840	(21.3)	0.125	(3.2)	0.250	(6.4)
03	0.965	(24.5)	0.156	(4.0)	0.375	(9.5)
04	1.090	(27.7)	0.281	(7.1)	0.500	(12.7)
05	1.215	(30.9)	0.406	(10.3)	0.625	(15.9)
06	1.340	(34.0)	0.531	(13.5)	0.750	(19.1)
07	1.465	(37.2)	0.656	(16.7)	0.875	(22.2)
08	1.590	(40.4)	0.781	(19.8)	1.000	(25.4)
09	1.715	(43.6)	0.906	(23.0)	1.125	(28.6)
10	1.840	(46.7)	1.031	(26.2)	1.250	(31.8)
11	1.965	(49.9)	1.156	(29.4)	1.375	(34.9)
12	2.090	(53.1)	1.281	(32.5)	1.500	(38.1)

Notes

- 1 Metric dimensions are shown in parentheses for reference only.
- 2 Cable range is defined as the envelope area of the cable or wire bundle. It is not intended for inspection criteria.
- 3 Consult factory when cable entry diameter exceeds Z diameter (see page 41).

Tolerance

Unless otherwise specified:
 .X ± .060 (1.5)
 .XX ± .030 (0.8)
 .XXX ± .015 (0.4)
 Angles ± 5 degrees

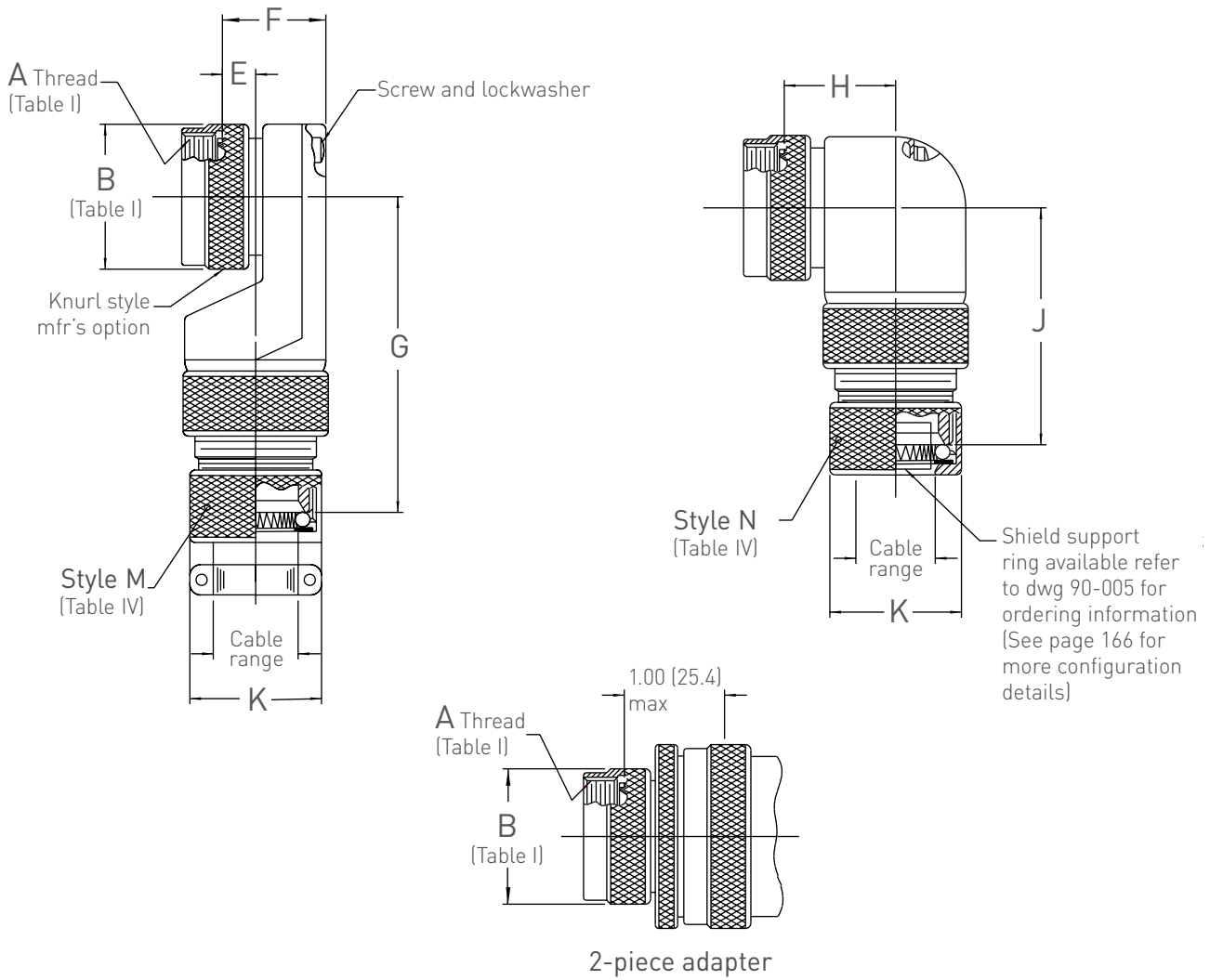

Example part number

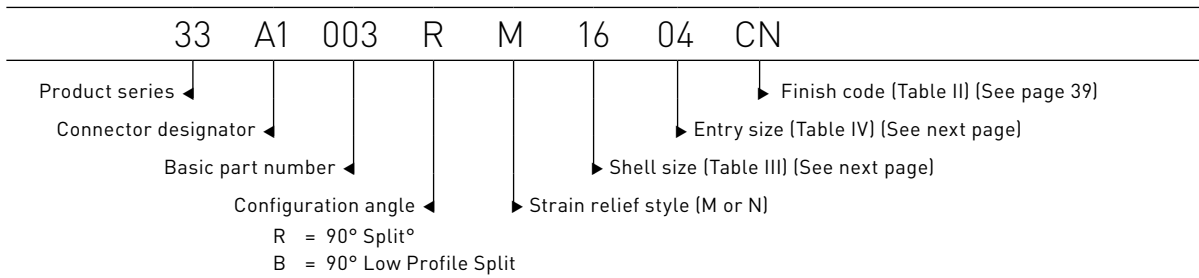

Table III

*Connector designator:												Maximum entry size availability	
Shell size		E		F		G		H		J		style B	style R
A1, F3, L1, X1	F4	max dimension		max dimension		max dimension		max dimension		max dimension			
08	09	0.496	(12.6)	0.837	(21.3)	1.660	(42.2)	0.772	(19.6)	1.460	(37.1)	02	02
10	11	0.426	(10.8)	0.887	(22.5)	1.860	(47.2)	0.834	(21.2)	1.520	(38.6)	03	03
12	13	0.426	(10.8)	0.887	(22.5)	1.860	(47.2)	0.897	(22.8)	1.590	(40.4)	03	04
14	15	0.436	(11.1)	0.987	(25.1)	1.880	(47.8)	0.960	(24.4)	1.620	(41.1)	04	05
16	17	0.576	(14.6)	1.137	(28.9)	1.970	(50.0)	1.022	(26.0)	1.720	(43.7)	05	06
18	19	0.796	(20.2)	1.337	(34.0)	1.990	(50.5)	1.084	(27.5)	1.780	(45.2)	05	07
20	21	0.796	(20.2)	1.337	(34.0)	1.990	(50.5)	1.147	(29.1)	1.840	(46.7)	05	08
22	23	0.696	(17.7)	1.337	(34.0)	2.200	(55.9)	1.210	(30.7)	1.900	(48.3)	06	09
24	25	0.696	(17.7)	1.337	(34.0)	2.200	(55.9)	1.272	(32.3)	1.960	(49.8)	06	10

* For connector family identification details see Page 17, Section I. Consult factory for availability of other connector designators not shown above.

Table IV

Entry size	K max	Cable range				
		min		max		
02	0.840	(21.3)	0.125	(3.2)	0.250	(6.4)
03	0.965	(24.5)	0.156	(4.0)	0.375	(9.5)
04	1.090	(27.7)	0.281	(7.1)	0.500	(12.7)
05	1.215	(30.9)	0.406	(10.3)	0.625	(15.9)
06	1.340	(34.0)	0.531	(13.5)	0.750	(19.1)
07	1.465	(37.2)	0.656	(16.7)	0.875	(22.2)
08	1.590	(40.4)	0.781	(19.8)	1.000	(25.4)
09	1.715	(43.6)	0.906	(23.0)	1.125	(28.6)
10	1.840	(46.7)	1.031	(26.2)	1.250	(31.8)

Notes

- 1 Metric dimensions are shown in parentheses for reference only.
- 2 When maximum cable entry is exceeded, style 2 will be supplied.
- 3 Cable range is defined as the envelope area of the cable or wire bundle. It is not intended for inspection criteria.

Tolerance

Unless otherwise specified:

.X ± .060 (1.5)

.XX ± .030 (0.8)

.XXX ± .015 (0.4)

Angles ± 5 degrees

Basic part designator	Product page	Configuration description
001	145	Adapters with the self-seating coupling ring feature that provide a total enclosure at the rear of the connector allowing for special test plugs or protection of special components.

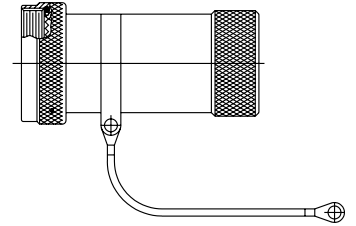

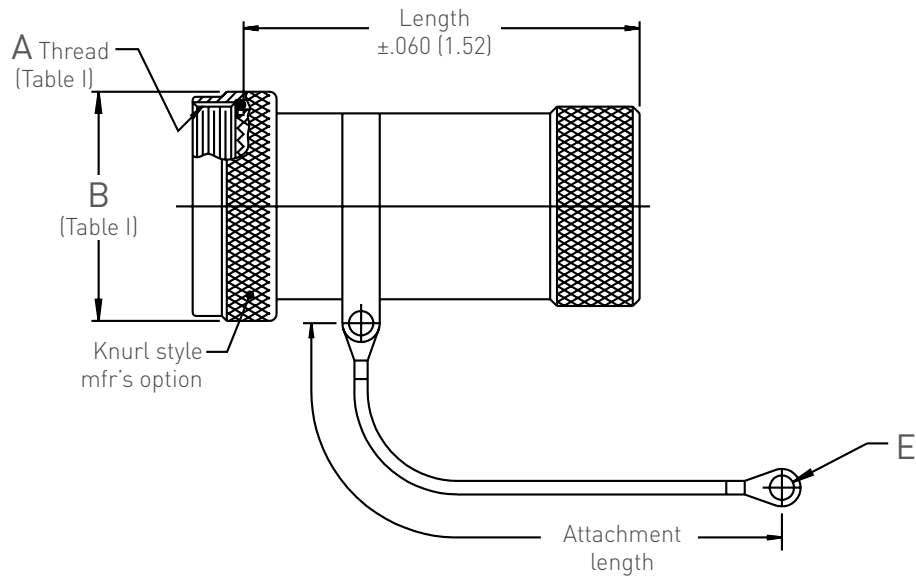

Example part number

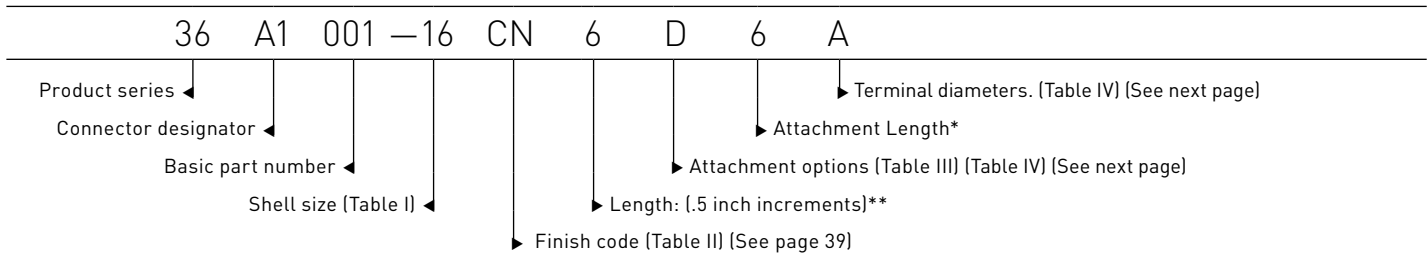

*[.5 inch increments.
E.G.: 6 = 3.0 inch length]

**1.0 inch min.
E.G.: 6 = 3.0 inch length]

Table III

Code symbol	Attachment description
A	No attachment, body strap only
B	Bead chain with terminal, brass/nickel plated
C	Link chain with reverse link, cres/passivated
D	Wire rope, nylon jacket, with terminal
E	Wire rope, PVC jacket, with terminal
N	Attachment omitted

For connector family identification details see Page 17, Section I. Consult factory for availability of other connector designators not shown above.

Table IV

Code symbol	E dia	
A	0.125	(3.2)
B	0.140	(3.6)
C	0.156	(4.0)
D	0.171	(4.3)
E	0.188	(4.8)
F	0.218	(5.5)

Notes

- 1 Metric dimensions are shown in parentheses for reference only.
- 2 O-ring not supplied on connector designators A1 and L1. F2 is moisture proof only.
- 3 Consult factory when cable entry diameter exceeds Z diameter (see page 41).

Tolerance

Unless otherwise specified:

- .X ± .060 (1.5)
- .XX ± .030 (0.8)
- .XXX ± .015 (0.4)
- Angles ± 5 degrees

Basic part designator	Product page	Configuration description
001	149	Adapters with the self-seating coupling ring to male or female pipe threads in straight and angled configurations

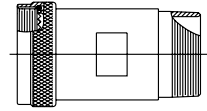

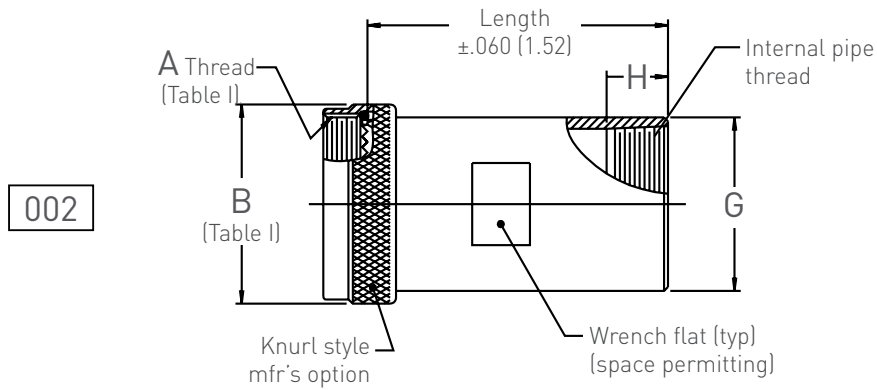
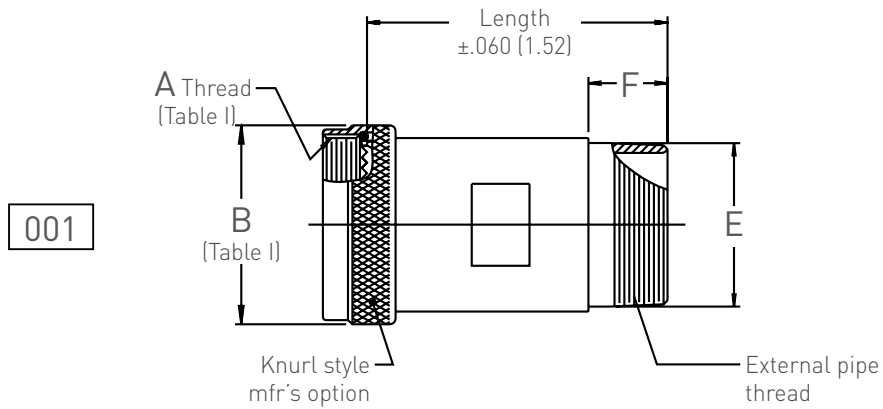

Example part number

39	A1	001	S	16	03	CN	3
Product series	Connector designator	Basic part number**	Configuration angle	Shell size (Table I)	Entry size (Table III) (See next page)	Finish code (Table II) (See page 39)	Length*
			S = straight B = 90° low profile split				
		** 001 - External pipe thd. 002 - Internal pipe thread					*[.5 inch increments, min. per Table III E.G.: 3 = 1.5 inch length]

Table III

Entry size	Pipe thread	E diameter		F dimension		G diameter		H dimension		Minimum order length		P/N desig
01	1/8	0.405	(10.3)	0.391	(9.9)	0.500	(12.7)	0.281	(7.1)	1.5	(38.1)	3
02	1/4	0.540	(13.7)	0.594	(15.1)	0.625	(15.9)	0.442	(11.2)	1.5	(38.1)	3
03	3/8	0.675	(17.1)	0.594	(15.1)	0.875	(22.2)	0.422	(10.7)	1.5	(38.1)	3
04	1/2	0.840	(21.3)	0.781	(19.8)	1.000	(25.4)	0.547	(13.9)	2.0	(50.8)	4
05	3/4	1.050	(26.7)	0.812	(20.6)	1.250	(31.8)	0.578	(14.7)	2.0	(50.8)	4
06	1	1.315	(33.4)	1.000	(25.4)	1.500	(38.1)	0.704	(17.9)	2.0	(50.8)	4
07	1 1/4	1.660	(42.2)	1.031	(26.2)	1.750	(44.5)	0.735	(18.7)	2.5	(63.5)	5
08	1 1/2	1.900	(48.3)	1.031	(26.2)	2.125	(54.0)	0.735	(18.7)	2.5	(63.5)	5
09	2	2.375	(60.3)	1.062	(27.0)	2.500	(63.5)	0.766	(19.5)	2.5	(63.5)	5
10	2 1/2	2.875	(73.0)	1.453	(36.9)	3.250	(82.6)	1.157	(29.4)	2.5	(63.5)	5
11	3	3.500	(88.9)	1.625	(41.3)	3.875	(98.4)	1.297	(32.9)	3.0	(76.2)	6

For connector family identification details see Page 17, Section I. Consult factory for availability of other connector designators not shown above.

Notes

- 1 Metric dimensions are shown in parentheses for reference only.
- 2 O-ring not supplied on connector designators A1 and L1. F2 is moisture proof only.
- 3 Not available on connector codes F3, F4 and X1.
- 4 Pipe threads per American standard for taper pipe threads.

Tolerance

- Unless otherwise specified:
- .X ± .060 (1.5)
- .XX ± .030 (0.8)
- .XXX ± .015 (0.4)
- Angles ± 5 degrees

Basic part designator	Product page	Configuration description
001 004	153 155	Adapters with lamp base threads for overall shield termination with heat shrinkable boot sealing capabilities in straight and angled configurations. Note: Shrink boot reference data is available on page 44

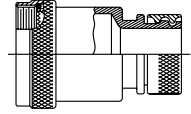

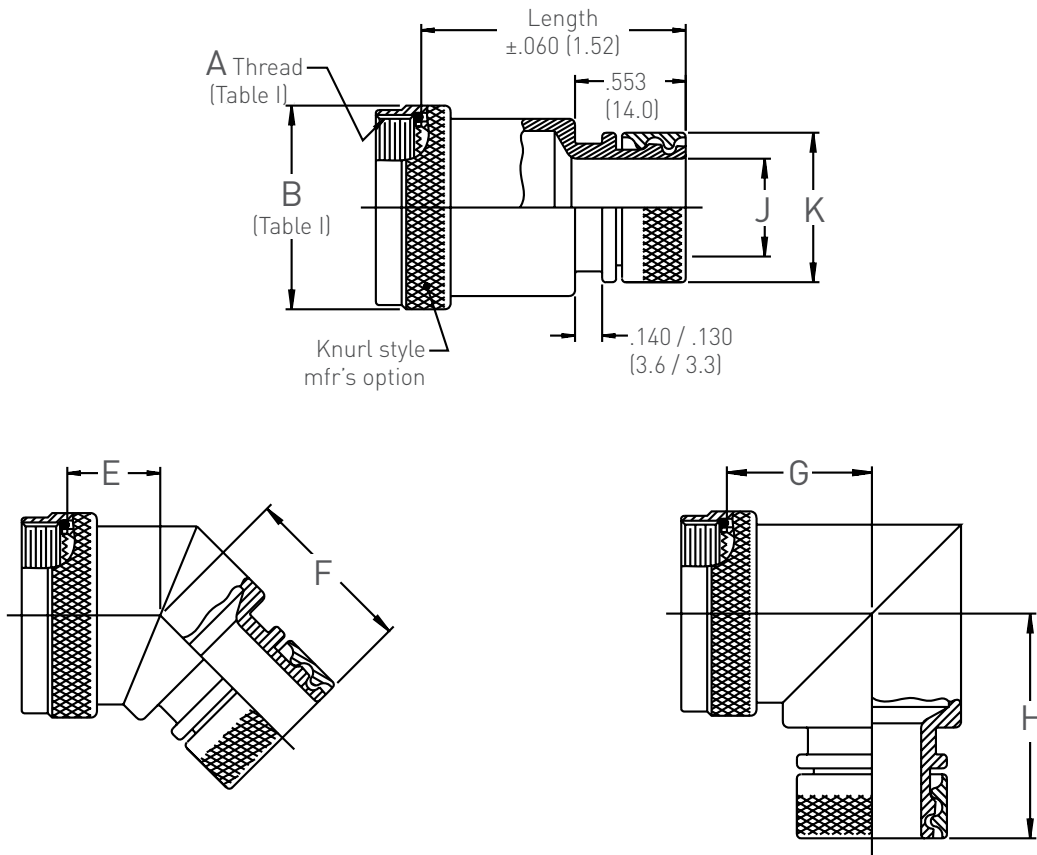

Example part number

51	F2	001	S	16	08	CN	6
Product series	Connector designator	Basic part number	Configuration angle	Shell size (Table III) (See next page)	Entry size (Table IV) (See next page)	Finish code (Table II) (See page 39)	Length: S Only*
			A = 45° R = 90° S = straight				*(.5 inch increments, 1.5 inch min. E.G.: 6 = 3.0 inch length)

Table III

*Connector designator									
Shell size		E		F		G		H	
A1, F2, L1, X1	F5	max dimension		max dimension		max dimension		max dimension	
08	09	0.612	(15.5)	0.989	(25.1)	0.727	(18.5)	1.124	(28.5)
10	11	0.675	(17.1)	1.021	(25.9)	0.831	(21.1)	1.193	(30.3)
12	13	0.698	(17.7)	1.047	(26.6)	0.886	(22.5)	1.249	(31.7)
14	15	0.723	(18.4)	1.067	(27.1)	0.946	(24.0)	1.334	(33.9)
16	17	0.748	(19.0)	1.093	(27.8)	1.008	(25.6)	1.390	(35.3)
18	19	0.767	(19.5)	1.112	(28.2)	1.052	(26.7)	1.446	(36.7)
20	21	0.793	(20.1)	1.138	(28.9)	1.115	(28.3)	1.501	(38.1)
22	23	0.818	(20.8)	1.164	(29.6)	1.177	(29.9)	1.484	(37.7)
24	25	0.844	(21.4)	1.184	(30.1)	1.240	(31.5)	1.626	(41.3)

* For connector family identification details see Page 17, Section I. Consult factory for availability of other connector designators not shown above.

Table IV

Entry size	J max		K max	
02	0.265	(6.7)	0.531	(13.5)
03	0.390	(9.9)	0.688	(17.5)
04	0.515	(13.1)	0.781	(19.8)
05	0.640	(16.3)	0.938	(23.8)
06	0.765	(19.4)	1.031	(26.2)
07	0.890	(22.6)	1.156	(29.4)
08	1.015	(25.8)	1.281	(32.5)
09	1.140	(29.0)	1.469	(37.3)
10	1.265	(32.1)	1.531	(38.9)
11	1.390	(35.3)	1.688	(42.9)
12	1.515	(38.5)	1.781	(45.2)

Notes

- 1 Metric dimensions are shown in parentheses for reference only.
- 2 O-ring not supplied on connector designators A1 and L1. F2 is moisture proof only.
- 3 See shrink boot reference data, page 44.
- 4 Consult factory when cable entry diameter exceeds Z diameter (see page 41).

Tolerance

Unless otherwise specified:
 .X ± .060 (1.5)
 .XX ± .030 (0.8)
 .XXX ± .015 (0.4)
 Angles ± 5 degrees

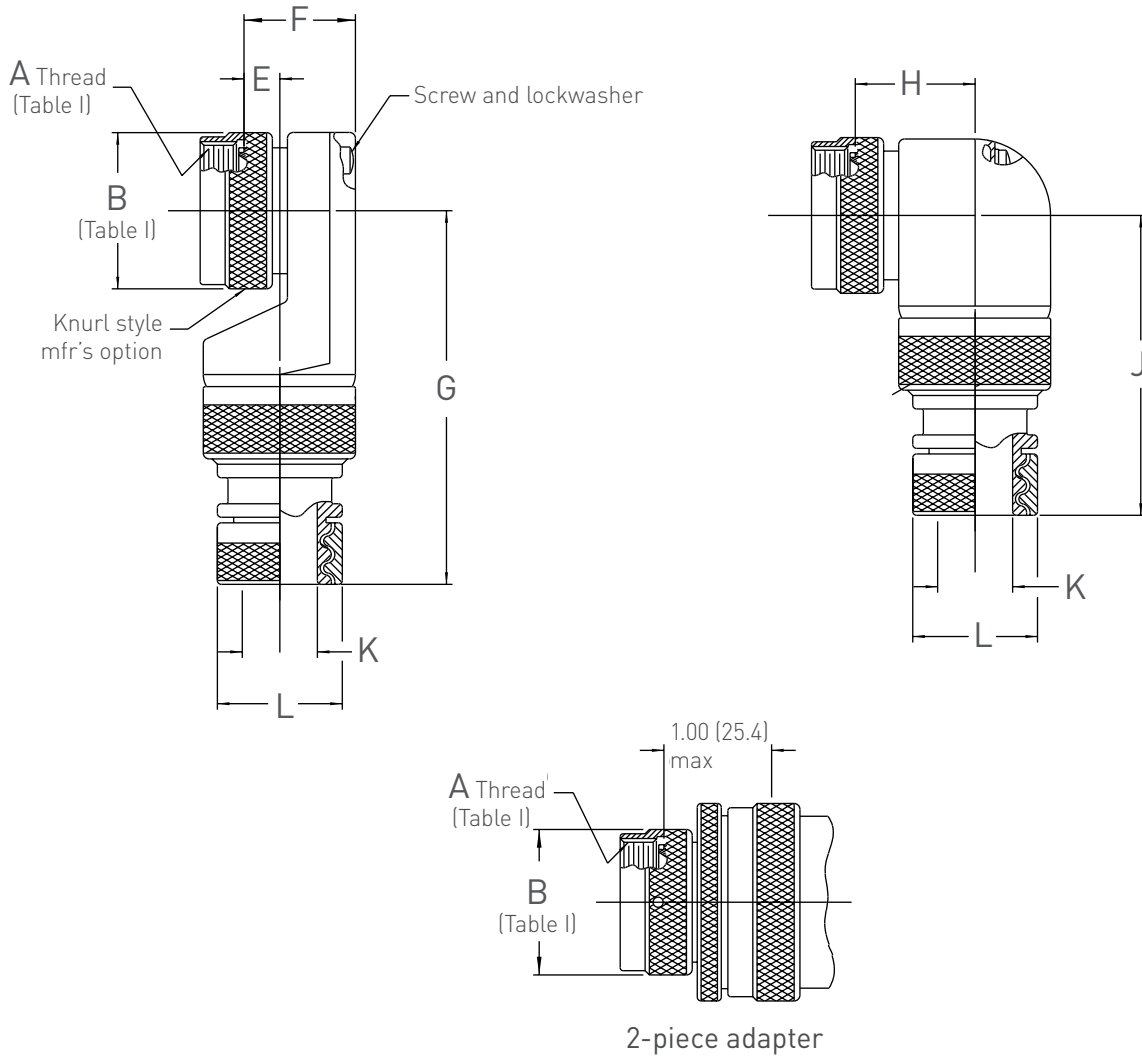

Example part number

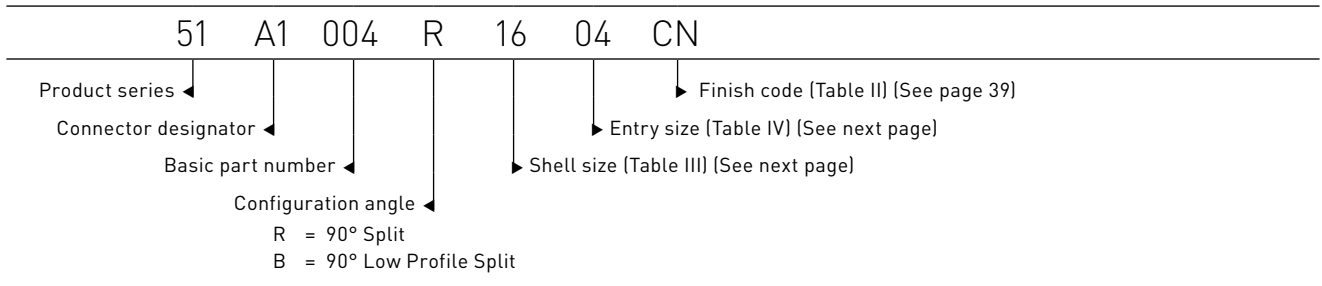

Table III

*Connector designator		E		F		G		H		J		Maximum entry size availability	
Shell size		max dimension		max dimension		max dimension		max dimension		max dimension		style B	style R
A1, F3, L1, X1	F4												
08	09	0.496	(12.6)	0.837	(21.3)	2.020	(51.3)	0.772	(19.6)	1.680	(42.7)	02	02
10	11	0.426	(10.8)	0.887	(22.5)	2.180	(55.4)	0.834	(21.2)	1.740	(44.2)	03	03
12	13	0.426	(10.8)	0.887	(22.5)	2.180	(55.4)	0.897	(22.8)	1.810	(46.0)	03	04
14	15	0.436	(11.1)	0.987	(25.1)	2.250	(57.2)	0.960	(24.4)	1.840	(46.7)	05	05
16	17	0.576	(14.6)	1.137	(28.9)	2.300	(58.4)	1.022	(26.0)	1.940	(49.3)	05	06
18	19	0.796	(20.2)	1.337	(34.0)	2.330	(59.2)	1.084	(27.5)	2.000	(50.8)	05	07
20	21	0.796	(20.2)	1.337	(34.0)	2.330	(59.2)	1.147	(29.1)	2.060	(52.3)	05	08
22	23	0.696	(17.7)	1.337	(34.0)	2.480	(63.0)	1.210	(30.7)	2.120	(53.8)	06	09
24	25	0.696	(17.7)	1.337	(34.0)	2.480	(63.0)	1.272	(32.3)	2.340	(59.4)	06	10

* For connector family identification details see Page 17, Section I. Consult factory for availability of other connector designators not shown above.

Table IV

Entry size	K		L	
	max		max	
02	0.265	(6.7)	0.531	(13.5)
03	0.390	(9.9)	0.688	(17.5)
04	0.515	(13.1)	0.781	(19.8)
05	0.640	(16.3)	0.938	(23.8)
06	0.765	(19.4)	1.031	(26.2)
07	0.890	(22.6)	1.156	(29.4)
08	1.015	(25.8)	1.281	(32.5)
09	1.140	(29.0)	1.469	(37.3)
10	1.265	(32.1)	1.531	(38.9)
11	1.390	(35.3)	1.688	(42.9)
12	1.515	(38.5)	1.781	(45.2)

Notes

- 1 Metric dimensions are shown in parentheses for reference only.
- 2 O-ring not supplied on connector designators A1 and L1. F2 is moisture proof only.
- 3 See shrink boot reference data, page 176

Tolerance

Unless otherwise specified:
 .X ± .060 (1.5)
 .XX ± .030 (0.8)
 .XXX ± .015 (0.4)
 Angles ± 5 degrees

Basic part designator	Product page	Configuration description
001	159	Adapters with the self-seating coupling ring feature that provides a convenient means to terminate Sealtite™/ Liquidtite™ conduit to a variety of circular connectors.

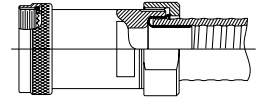

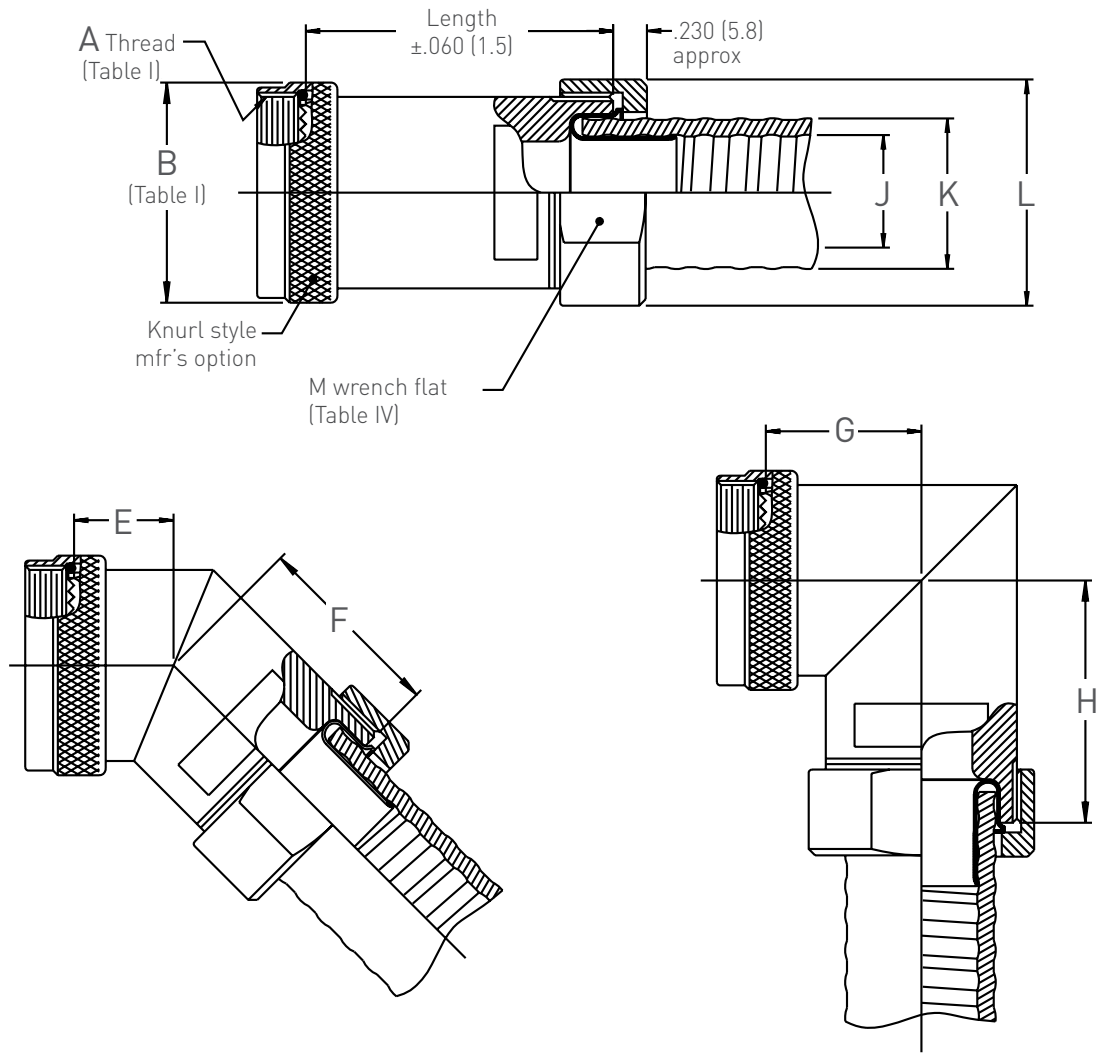

Example part number

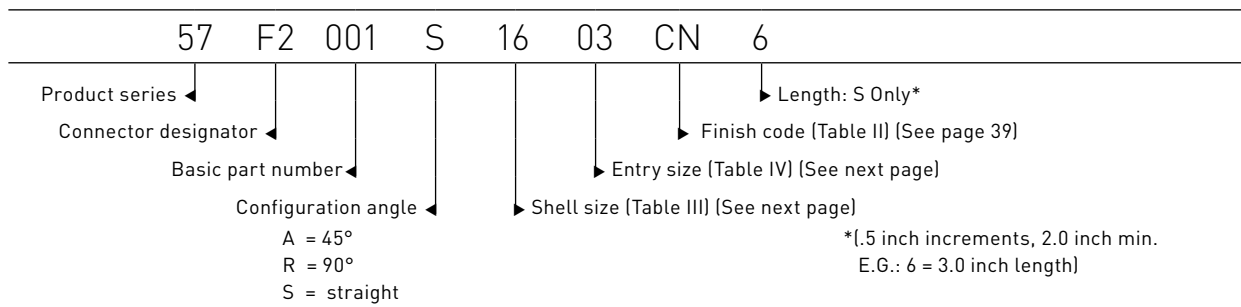

Table III

*Connector designator		E		F		G		H	
Shell size		max dimension		max dimension		max dimension		max dimension	
A1, F2, L1, X2	F5								
08	09	0.612	(15.5)	1.268	(32.2)	0.727	(18.5)	1.374	(34.9)
10	11	0.675	(17.1)	1.296	(32.9)	0.831	(21.1)	1.430	(36.3)
12	13	0.698	(17.7)	1.319	(33.5)	0.886	(22.5)	1.486	(37.7)
14	15	0.723	(18.4)	1.344	(34.1)	0.946	(24.0)	1.552	(39.4)
16	17	0.748	(19.0)	1.369	(34.8)	1.008	(25.6)	1.610	(40.9)
18	19	0.767	(19.5)	1.388	(35.3)	1.052	(26.7)	1.671	(42.4)
20	21	0.793	(20.1)	1.414	(35.9)	1.115	(28.3)	1.741	(44.2)
22	23	0.818	(20.8)	1.439	(36.6)	1.177	(29.9)	1.794	(45.6)
24	25	0.844	(21.4)	1.465	(37.2)	1.240	(31.5)	1.862	(47.3)

* For connector family identification details see Page 17, Section I. Consult factory for availability of other connector designators not shown above.

Table IV

Entry size	Conduit size (ref)	J max		K max		L max		M wrench flat (ref)	
01	3/8	0.504	(12.8)	0.710	(18.0)	1.140	(29.0)	1.000	(25.4)
02	1/2	0.642	(16.3)	0.840	(21.3)	1.265	(32.1)	1.125	(28.6)
03	3/4	0.840	(21.3)	1.050	(26.7)	1.515	(38.5)	1.375	(24.9)
04	1	1.066	(27.1)	1.315	(33.4)	1.765	(44.8)	1.625	(41.3)
05	1 1/4	1.410	(35.8)	1.660	(42.2)	2.140	(54.4)	2.000	(50.8)
06	1 1/2	1.600	(40.6)	1.900	(48.3)	2.390	(60.7)	2.250	(57.2)
07	2	2.045	(51.9)	2.375	(60.3)	2.827	(71.8)	2.688	(68.3)

Notes

- Metric dimensions are shown in parentheses for reference only.
- O-ring not supplied on connector designators A1 and L1. F2 is moisture proof only.
- Cable range is defined as the envelope area of the cable or wire bundle. It is not intended for inspection criteria.
- Consult factory when cable entry diameter exceeds Z diameter (see page 41).

Tolerance

Unless otherwise specified:
 .X ± .060 (1.5)
 .XX ± .030 (0.8)
 .XXX ± .015 (0.4)
 Angles ± 5 degrees

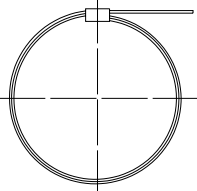
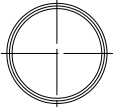
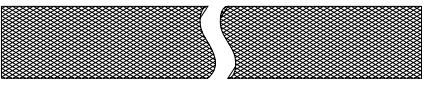
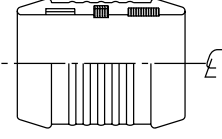
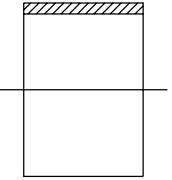
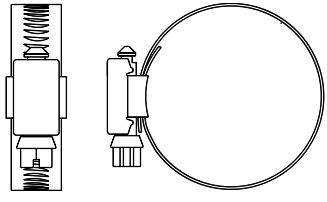
Basic part designator	Product page	Configuration description	
001	163	Stainless steel metal band for overall and/or individual shield termination used in conjunction with Sunbank series 03/06 adapters and Sunbank Series 99 application tools.	
002	163	Field repairable stainless steel metal band for overall shield termination used with Sunbank Series 03/06 adapters.	
003	164	Tin-copper braid for shielding wire bundles, cables or similar products can be ordered in 1 foot increments.	
004	165	Shield support ring for cable splicing, or repair, of overall shielded cables, or cable bundles used with Sunbank Series 03/06 band products.	
005	166	Shield support ring recommended for use with Sunbank Series 33 adapter products.	
006	168	Shield clamp with adjustable range for use with Sunbank Series 03**011 adapter products.	

Band and constant force spring data

Accessory entry size	Accessory ID. ± .015		Sunband™ p/n 90-001- std size	90-002- cfs size
02	0.125	(3.2)	2	N/A
04	0.250	(6.4)	2	1
06	0.375	(9.5)	2	1
08	0.500	(12.7)	2	2
10	0.625	(15.9)	2	2
12	0.750	(19.1)	2	3
14	0.875	(22.2)	2	3
16	1.000	(25.4)	2	3
18	1.125	(28.6)	2	3
20	1.250	(31.8)	2	4

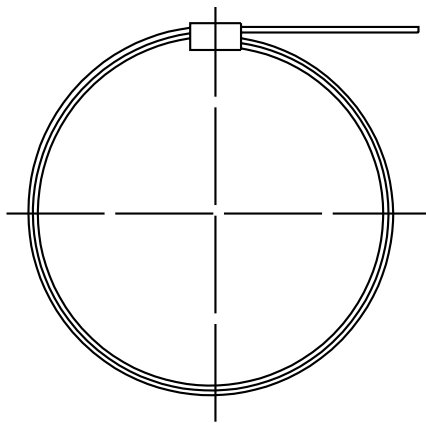

90-001
Sunband™

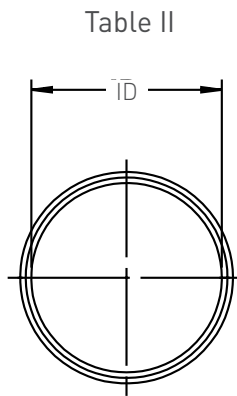

90-002
Constant force spring

Table II

Dash no	ID (ref)	
1	.36	(9.1)
2	.57	(14.5)
3	.73	(18.5)
4	.98	(24.9)

Notes

- 1 Metric dimensions are shown in parentheses for reference only.
- 2 See Sunbank modification codes page 42, to add Sunband™ or constant force spring to accessory.
- 3 Consult factory when cable entry diameter exceeds Z diameter.
- 4 See page 169 for assembly tools.

Example part number with mod code

03A1001S1608CN6-114

Reference banding adapter (Series 03) ↓

↓ Mod Code providing 90-001-2 Band (See page 42 for mod codes)

Tubular braid support data

Dash number	Wire size gage	Nominal ID	Number of carriers	Number of ends	Current rating (amps)
031	36	.031(0.8)	24	24	7.0
062	36	.062 (1.6)	24	48	11.0
078	36	.078 (2.0)	24	72	16.0
109	36	.109 (2.8)	24	96	19.0
125	36	.125 (3.2)	24	120	25.0
156	36	.156 (4.0)	24	240	40.0
171	36	.171 (4.3)	24	168	32.0
203	36	.203 (5.2)	24	312	46.0
250	36	.250 (6.4)	24	384	53.0
375	36	.375 (9.5)	48	384	53.0
500	36	.500 (12.7)	48	528	62.0
562	30	.562 (14.3)	48	480	145.0
656	30	.656 (16.7)	48	768	190.0
781	36	.781 (19.8)	48	864	88.0
1000	30	1.000 (25.4)	48	384	120.0
1125	30	1.125 (28.6)	48	432	130.0
1375	30	1.375 (34.9)	48	528	150.0

Notes

- 1 Metric dimensions are shown in parentheses for reference only.
- 2 Material: tin coated copper per QQ-B-575B, ASTM B33.
- 3 Direct current ratings are given for information only and are not requirements. Values shown are for uninsulated braid in free air at 80 degrees F (30 degrees C). Values should be derated if the braid is insulated or in close contact with other components.
- 4 Consult factory when cable entry diameter exceeds Z diameter.

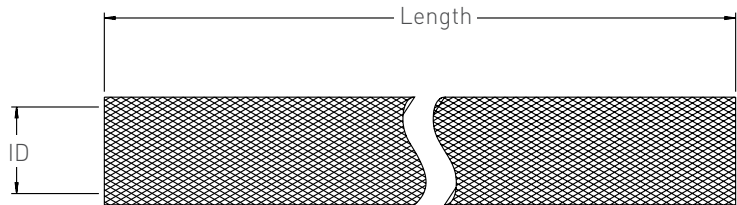

Example part number

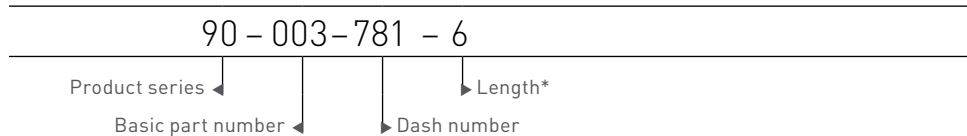

*(1 Ft. min. in 1 Ft. increments
e.g.: 6 = 6 Feet)

Split shield support ring data

Entry size	X dia. ± .010	Y dia. ± .010	Z dia. ± .010	90-001-for ref only	
				Std size	Mini size
04	.250 (6.4)	.404 (10.3)	.360 (9.1)	2	3 or 4
06	.375 (9.5)	.529 (13.4)	.485 (12.3)	2	3 or 4
08	.500 (12.7)	.654 (16.6)	.610 (15.5)	2	3 or 4
10	.625 (15.9)	.779 (19.8)	.735 (18.7)	2	3 or 4
12	.750 (19.1)	.904 (23.0)	.860 (24.8)	2	3 or 4
14	.875 (22.2)	1.029 (26.1)	.985 (25.0)	2	3 or 4
16	1.000 (25.4)	1.154 (29.3)	1.110 (28.2)	2	3 or 4
18	1.125 (28.6)	1.279 (32.5)	1.235 (31.4)	2	3 or 4
20	1.250 (31.8)	1.404 (35.7)	1.360 (34.5)	2	3 or 4
22	1.375 (34.9)	1.529 (38.9)	1.485 (37.7)	2	4
24	1.500 (38.1)	1.654 (42.0)	1.610 (40.9)	2	4
26	1.625 (41.3)	1.779 (45.2)	1.735 (44.1)	2	4
28	1.750 (44.5)	1.904 (48.6)	1.860 (47.2)	2	4

Notes

- 1 Material is thermoplastic.
- 2 Supplied unplated.
- 3 Consult factory when cable entry diameter exceeds Z diameter.

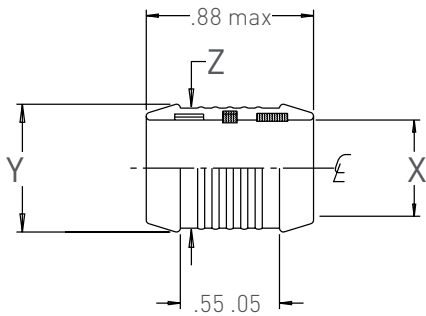

Example part number

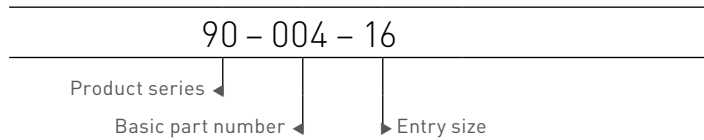

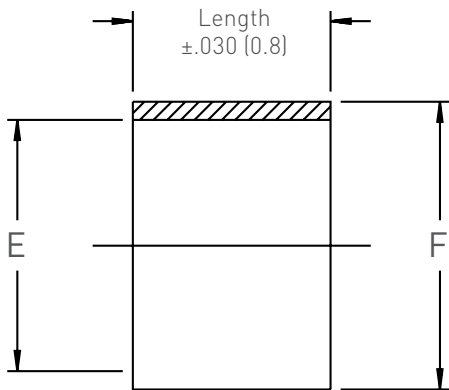

Example part number

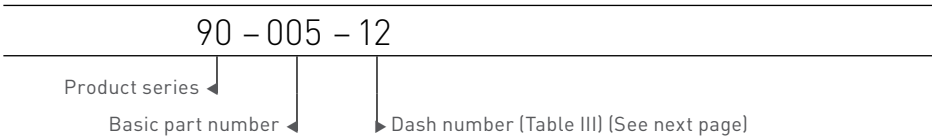

Table III

Dash no.	E ± .010 (0.3)		F ± .010 (0.3)		Length ± .010 (0.8)	
01	0.187	(4.7)	0.227	(5.8)	0.500	(12.7)
02	0.218	(5.5)	0.258	(6.6)	0.500	(12.7)
03	0.250	(6.4)	0.290	(7.4)	0.500	(12.7)
04	0.281	(7.1)	0.321	(8.2)	0.500	(12.7)
05	0.312	(7.9)	0.352	(8.9)	0.500	(12.7)
06	0.343	(8.7)	0.383	(9.7)	0.500	(12.7)
07	0.375	(9.5)	0.415	(10.5)	0.500	(12.7)
08	0.406	(10.3)	0.446	(11.3)	0.500	(12.7)
09	0.438	(11.1)	0.478	(12.1)	0.500	(12.7)
10	0.469	(11.9)	0.508	(12.9)	0.500	(12.7)
11	0.500	(12.7)	0.540	(13.7)	0.500	(12.7)
12	0.531	(13.5)	0.571	(14.5)	0.500	(12.7)
13	0.562	(14.3)	0.602	(15.3)	0.500	(12.7)
14	0.593	(15.1)	0.633	(16.1)	0.500	(12.7)
15	0.625	(15.9)	0.665	(16.9)	0.500	(12.7)
16	0.656	(16.7)	0.696	(17.7)	0.500	(12.7)
17	0.687	(17.4)	0.727	(18.5)	0.500	(12.7)
18	0.718	(18.2)	0.758	(19.3)	0.500	(12.7)
19	0.750	(19.1)	0.790	(20.1)	0.750	(19.1)
20	0.781	(19.8)	0.821	(20.9)	0.750	(19.1)
21	0.812	(20.6)	0.852	(21.6)	0.750	(19.1)
22	0.843	(21.4)	0.883	(22.4)	0.750	(19.1)
23	0.875	(22.2)	0.915	(23.2)	0.750	(19.1)
24	0.906	(23.0)	0.946	(24.0)	0.750	(19.1)
25	0.937	(23.8)	0.977	(24.8)	0.750	(19.1)
26	0.968	(24.6)	1.008	(25.6)	0.750	(19.1)
27	1.000	(25.4)	1.040	(26.4)	0.750	(19.1)

Table III

Dash no.	E ± .010 (0.3)		F ± .010 (0.3)		Length ± .010 (0.8)	
28	1.031	(26.2)	1.071	(27.2)	0.750	(19.1)
29	1.062	(27.0)	1.102	(28.0)	0.750	(19.1)
30	1.093	(27.8)	1.133	(28.8)	0.750	(19.1)
31	1.125	(28.6)	1.165	(29.6)	0.750	(19.1)
32	1.156	(29.4)	1.196	(30.4)	0.750	(19.1)
33	1.187	(30.1)	1.227	(31.2)	0.750	(19.1)
34	1.218	(30.9)	1.258	(32.0)	0.750	(19.1)
35	1.250	(31.8)	1.290	(32.8)	0.750	(19.1)
36	1.281	(32.5)	1.321	(33.6)	0.750	(19.1)
37	1.312	(33.3)	1.352	(34.3)	1.000	(25.4)
38	1.343	(34.1)	1.383	(35.1)	1.000	(25.4)
39	1.375	(34.9)	1.415	(35.9)	1.000	(25.4)
40	1.406	(35.7)	1.446	(36.7)	1.000	(25.4)
41	1.437	(36.5)	1.477	(37.5)	1.000	(25.4)
42	1.468	(37.3)	1.508	(38.3)	1.000	(25.4)
43	1.500	(38.1)	1.540	(39.1)	1.000	(25.4)
44	1.531	(38.9)	1.571	(39.9)	1.000	(25.4)
45	1.562	(39.7)	1.602	(40.7)	1.000	(25.4)
46	1.593	(40.5)	1.633	(41.5)	1.000	(25.4)
47	1.625	(41.3)	1.665	(42.3)	1.000	(25.4)
48	1.656	(42.1)	1.696	(43.1)	1.000	(25.4)
49	1.687	(42.8)	1.727	(43.9)	1.000	(25.4)
50	1.718	(43.6)	1.758	(44.7)	1.000	(25.4)
51	1.750	(44.5)	1.790	(45.5)	1.000	(25.4)
52	1.781	(45.2)	1.821	(46.3)	1.000	(25.4)
53	1.812	(46.0)	1.852	(47.0)	1.000	(25.4)
54	1.843	(46.8)	1.883	(47.8)	1.000	(25.4)

Notes

- 1 Metric dimensions are shown in parentheses for reference only.
- 2 Finish: anodize, clear non-conductive.
- 3 Consult factory when cable entry diameter exceeds Z diameter.

Tolerance

- Unless otherwise specified:
- .X ± .060 (1.5)
- .XX ± .030 (0.8)
- .XXX ± .015 (0.4)
- Angles ± 5 degrees

Table I

Dash number	Inside diameter			
	max		min	
11	.78	(19.8)	.44	(11.2)
32	.90	(22.9)	.50	(12.7)
14	1.125	(31.8)	.69	(17.5)
15	1.50	(38.1)	.82	(20.8)
16	1.75	(44.5)	.82	(20.8)
17	2.00	(50.8)	1.06	(26.9)

Notes

- 1 Metric dimensions are shown in parentheses for reference only.
- 2 Consult factory when cable entry diameter exceeds Z diameter.

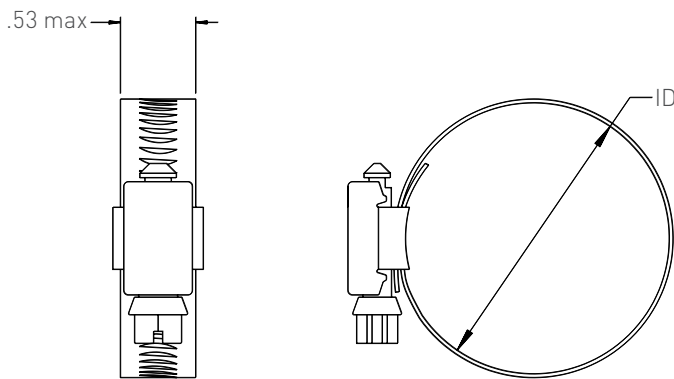

Example part number

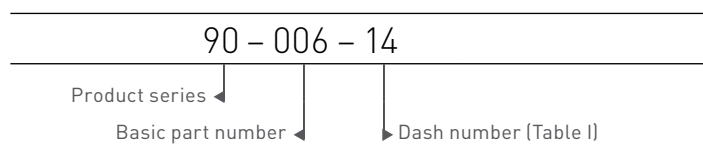

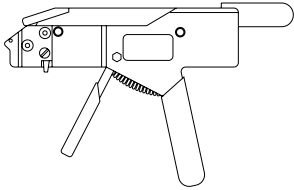
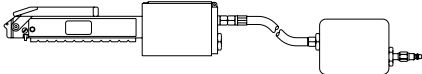
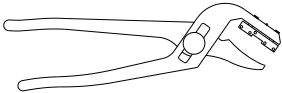
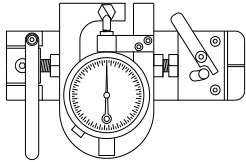
Basic part designator	Product page	Configuration description	
001	170	Banding application tools for terminating Sunbank Series 90-001 stainless steel metal bands.	
002	171	Pneumatic banding application tools for terminating Sunbank Series 90-001 stainless steel metal bands.	
003	172	Band roll-over tools for terminating Sunbank Series 90-001 stainless steel metal bands.	
004	173	Calibration and inspection tools for Sunbank Series 99-001 band application tools.	

Band application tool data

Part number	Tool description	Weight lbs	Identification number	Patent number
99-001				
1100	Standard band application tool	1.38	STS-1100	5,000,232
1101	Standard band application tool/roll-over tool	2.32	STS-1101	
1200	Mini-band application tool	1.38	STS-1200	5,000,232
1201	Mini-band application tool/roll-over tool	2.32	STS-1201	

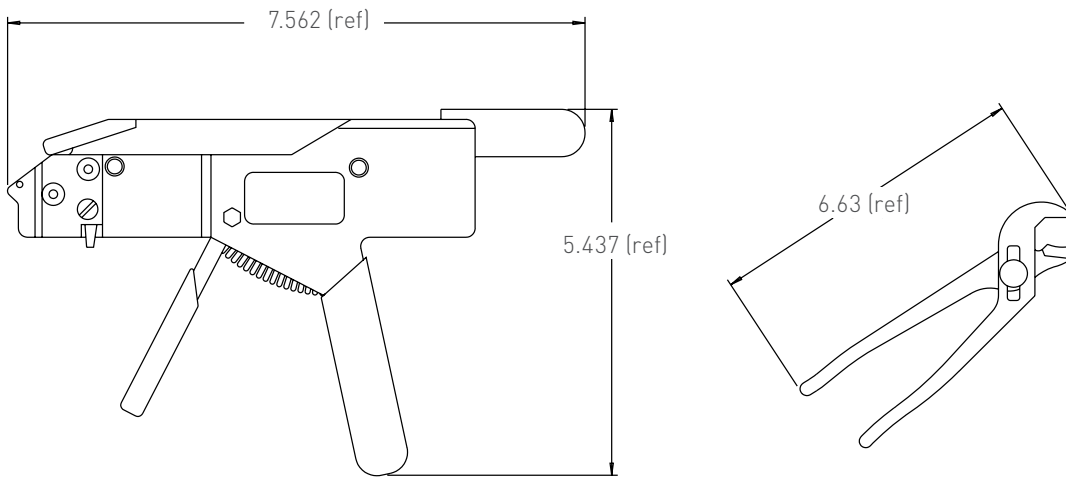

Tools shown above are supplied under identification number STS-1101 or STS 1201

Example part number

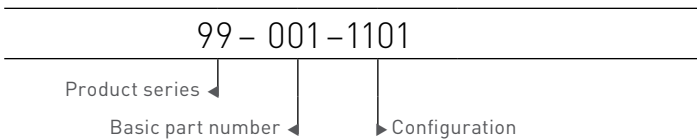

Band application tool data – pneumatic tools

Part number	Tool description	Weight lbs	Identification number
99-002			
1100	Standard band application tool	3.05	STS-P1
1200	Mini-band application tool	3.05	STS-P2

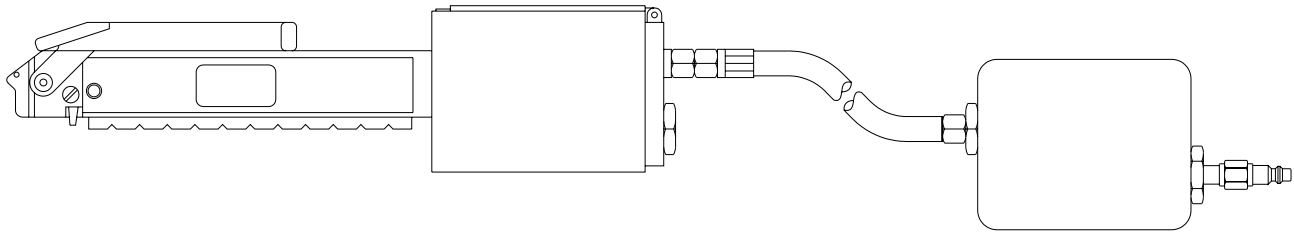

Example part number

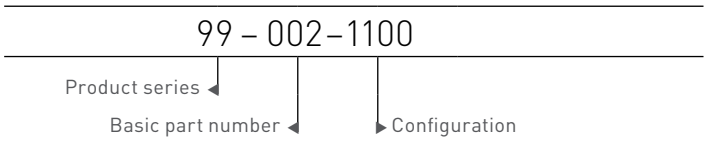

Band application tool data

Part number	Tool description	Weight lbs	Identification number
99-003			
R03	Roll-over tool	0.94	STS-R03
RPI	Roll-over tool (modified plier version)	3.05	STS-RPI
BRI	Band removal tool	0.68	STS-BRI

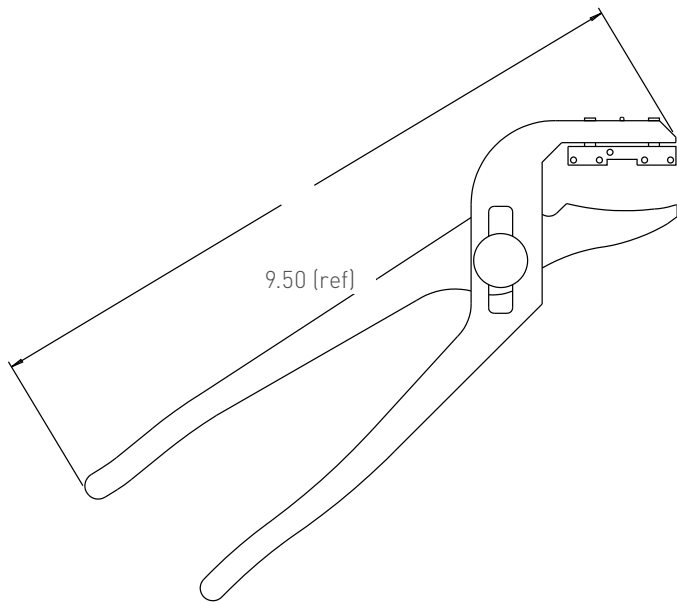

Identification number STS-R03

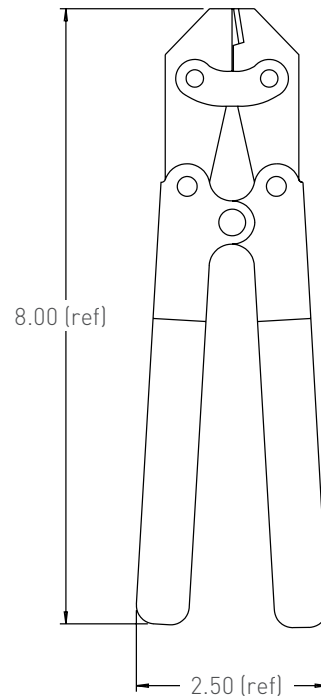

Identification number STS-BR1

Example part number

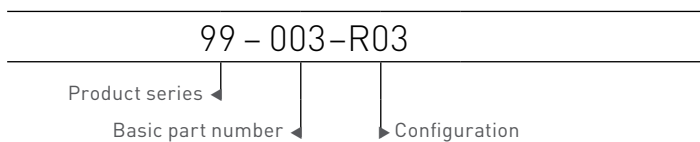

Band application tool data – calibration/inspection tools

Part number	Tool description	Weight lbs	Identification number
99-004			
CT	Calibration gage/fixture	3.30	STS-CT
CT1	Calibration inspection fixture	0.31	STS-CT1
CT2	Go/no-go inspection gage	0.03	STS-CT2
CT3	Inspection fixture and go/no-go gage	0.34	STS-CT3
CG3	Calibration inspection fixture (mini-band)	0.31	STS-CG3
CT4	Go/no-go inspection gage (mini-band)	0.03	STS-CT4
CT4A	Inspection fixture and go/no-go gage (mini-band)	0.34	STS-CT4A

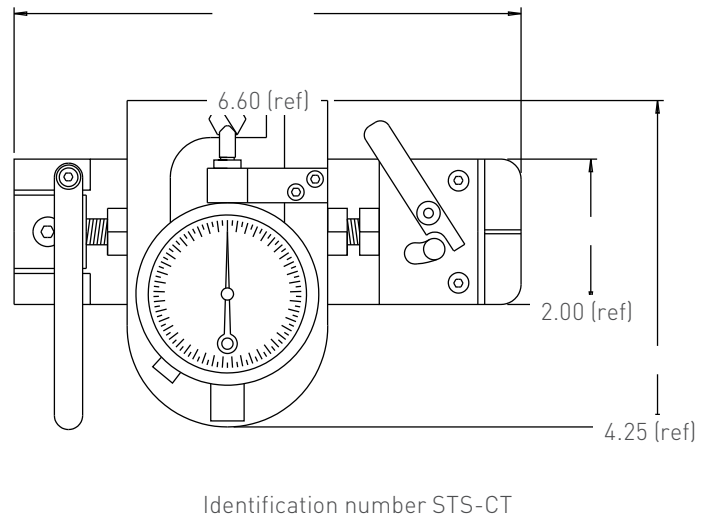
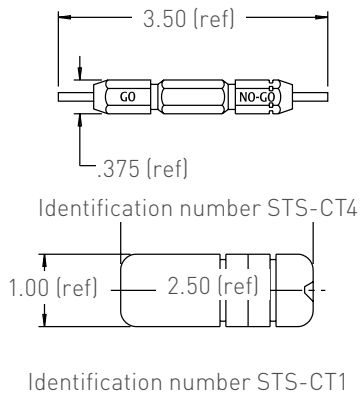

Example part number

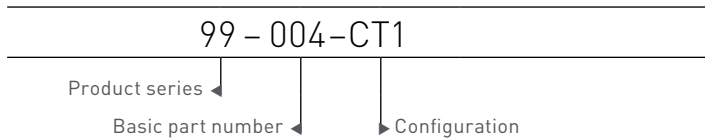

Reliable People, Reliable Solutions



www.sunbankcorp.com
info@sunbankcorp.com



SUNBANK