

Automotive LED Array Driver

FEATURES AND BENEFITS

- AEC-Q100 qualified
- Total LED drive current up to 400 mA
- Current shared equally up to 100 mA by 4 strings
- 6 to 50 V supply
- Low dropout voltage
- LED output short-to-ground and thermal protection
- On/off toggle switch input
- Enable input for PWM control
- Current slew rate limit during PWM
- Current set by reference resistor
- Automotive temperature range

APPLICATIONS:

- Dome light, map light, space lighting, mood lighting

PACKAGES:

10-pin MSOP with exposed thermal pad (suffix LY)

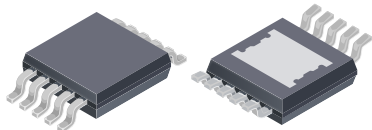

16-pin TSSOP with exposed thermal pad (suffix LP)

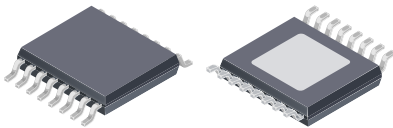

Not to scale

DESCRIPTION

The A6262 is a linear, programmable current regulator providing up to 100 mA from each of four outputs to drive arrays of high brightness LEDs. The regulated LED current from each output, accurate to 5%, is set by a single reference resistor. Current matching in each string is better than 10% without the use of ballast resistors. Driving LEDs with constant current ensures safe operation with maximum possible light output.

Output control is provided by an enable input, giving direct control for PWM applications, and by a debounced switch input, proving an on/off toggle action.

Optimum performance is achieved driving 1 to 3 LEDs in each string: up to 4 strings at 100 mA each. Outputs can be connected in parallel or left unused as required.

Short detection is provided to protect the LEDs and the A6262 during a short-to-ground at any LED output pin. The output will automatically resume the regulated current when the short is removed.

A temperature monitor is included to reduce the LED drive current if the chip temperature exceeds an adjustable thermal threshold.

The device packages are a 10-pin MSOP (suffix LY), and a 16-pin TSSOP (LP), both with exposed pad for enhanced thermal dissipation. They are lead (Pb) free, with 100% matte tin leadframe plating.

Typical Application Diagram

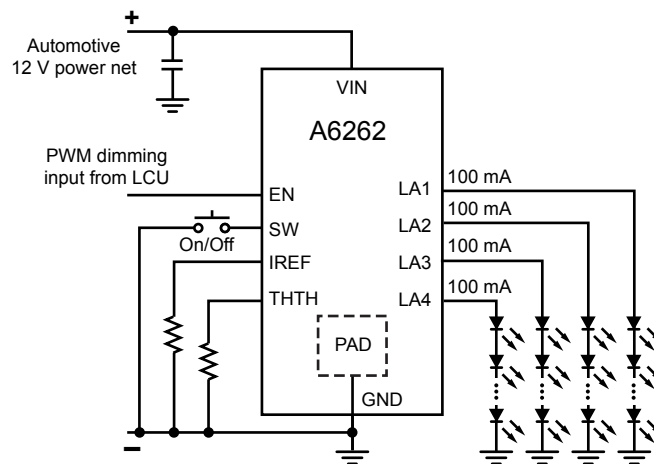

Selection Guide

Part Number	Ambient Operating Temperature, T_A (°C)	Packing	Package
A6262KLPTR-T	-40 to 125	4000 pieces per 13-in. reel	16-pin TSSOP with exposed thermal pad, 4.4 × 5 mm case
A6262KLYTR-T			10-pin MSOP with exposed thermal pad, 3 × 3 mm case

Absolute Maximum Ratings¹

Characteristic	Symbol	Notes	Rating	Unit
Load Supply Voltage	V_{IN}		-0.3 to 50	V
Pin EN			-0.3 to 50	V
Pins LA[1:4]			-0.3 to 50	V
Pins IREF, THTH, SW			-0.3 to 6.5	V
Ambient Operating Temperature Range ²	T_A	K temperature range	-40 to 125	°C
Maximum Continuous Junction Temperature	$T_J(\text{max})$		150	°C
Transient Junction Temperature	T_{TJ}	Over temperature event not exceeding 10 s, lifetime duration not exceeding 10 h, guaranteed by design characterization	175	°C
Storage Temperature Range	T_{stg}		-55 to 150	°C

¹With respect to GND.

²Limited by power dissipation.

Thermal Characteristics*may require derating at maximum conditions, see application information

Characteristic	Symbol	Test Conditions*	Value	Unit	
Package Thermal Resistance (Junction to Ambient)	$R_{\theta JA}$	LP package	On 4-layer PCB based on JEDEC standard	34	°C/W
			On 2-layer PCB with 3.8 in. ² of copper area each side	43	°C/W
		LY package	On 4-layer PCB based on JEDEC standard	48	°C/W
			On 2-layer PCB with 2.5 in. ² of copper area each side	48	°C/W
Package Thermal Resistance (Junction to Pad)	$R_{\theta JP}$		2	°C/W	

*To be verified by characterization. Additional thermal information available on the Allegro™ website.

Functional Block Diagram

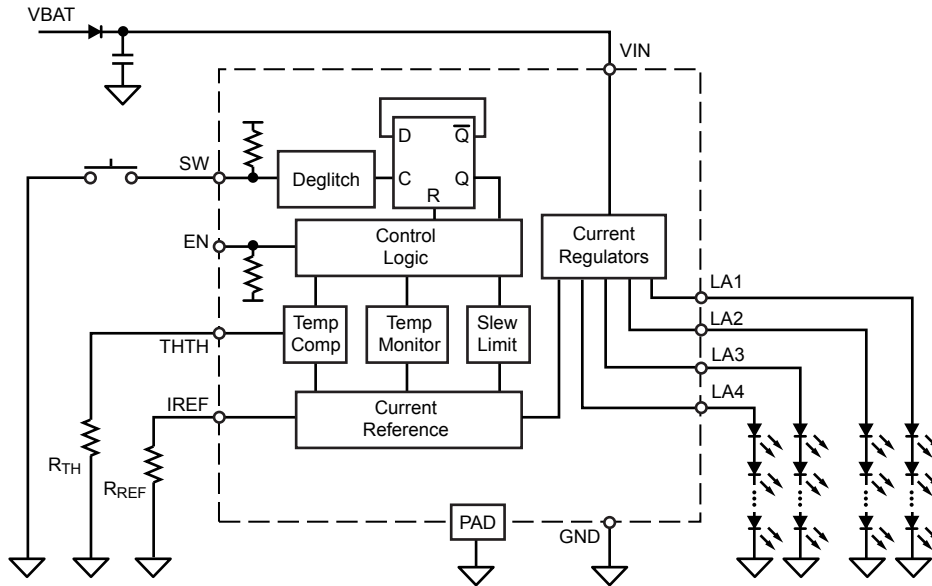

Pinout Diagrams

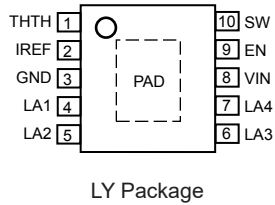
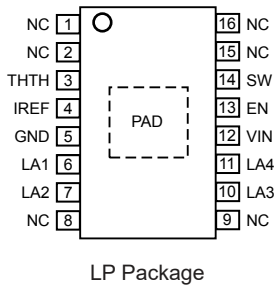

Terminal List Table

Name	Number		Function
	LP	LY	
EN	13	9	Enable
SW	14	10	Switch input
GND	5	3	Ground reference
IREF	4	2	Current reference
LA1	6	4	LED anode (+) connection 1
LA2	7	5	LED anode (+) connection 2
LA3	10	6	LED anode (+) connection 3
LA4	11	7	LED anode (+) connection 4
NC	1,2,8, 9,15,16	n.a.	No connection; connect to GND
PAD	–	–	Exposed thermal pad
THTH	3	1	Thermal threshold
VIN	12	8	Supply

ELECTRICAL CHARACTERISTICS¹ Valid at $T_J = -40^\circ\text{C}$ to 150°C , $V_{IN} = 7$ to 40 ; unless otherwise noted

Characteristics	Symbol	Test Conditions	Min.	Typ.	Max.	Unit
Supply and Reference						
V_{IN} Functional Operating Range ²			6	–	50	V
V_{IN} Quiescent Current	I_{INQ}	LA[1:4] connected to VIN	–	–	10	mA
V_{IN} Sleep Current	I_{INS}	EN = GND, $V_{IN} = 16$ V	–	–	15	μA
Startup Time	t_{ON}	$V_{IN} > 7$ V to $I_{LA1} < -5$ mA, $R_{REF} = 125 \Omega$	5	15	30	μs
Current Regulation						
Reference Voltage	V_{IREF}	$0.7 \text{ mA} < I_{REF} < 8.8 \text{ mA}$	1.15	1.2	1.25	V
Reference Current Ratio	G_H	I_{LAX} / I_{REF}	–	12.5	–	–
Current Accuracy ³	E_{ILAX}	$-10 \text{ mA} > I_{LAX} > -100 \text{ mA}$	–5	± 4	5	%
Current Matching ⁴	E_{IMLAX}	$-20 \text{ mA} > I_{LAX} > -100 \text{ mA}$, V_{LAX} match to within 1 V	–	5	10	%
Output Current, High Level	I_{LAX}	EN = high	–	$G_H \times I_{REF}$	–	–
		$I_{REF} = 8 \text{ mA}$, EN = high	–105	–100	–95	mA
Maximum Output Current	I_{LAXmax}	$I_{REF} = 9.2 \text{ mA}$, EN = high	–	–	–110	mA
Minimum Drop-out Voltage	V_{DO}	$V_{IN} - V_{LAX}$, $I_{LAX} = -100 \text{ mA}$	–	–	800	mV
		$V_{IN} - V_{LAX}$, $I_{LAX} = -40 \text{ mA}$	–	–	660	mV
Current Slew Time		Current rising or falling between 10% and 90%	50	80	110	μs
Logic Inputs EN and SW						
Input Low Voltage	V_{IL}		–	–	0.8	V
Input High Voltage	V_{IH}		2	–	–	V
Input Hysteresis (EN pin)	V_{IHys}		150	350	–	mV
Pull-Down Resistor (EN pin)	R_{PD}		–	50	–	k Ω
Pull-Up Current (SW pin)	I_{PU}		–	100	–	μA
SW Input Debounce Time	t_{SW}		10	–	50	ms
Protection						
Short Detect Voltage	V_{SCD}	Measured at LAX	1.2	–	1.8	V
Short Circuit Source Current	I_{SCS}	Short present LAX to GND	–2	–0.8	–0.5	mA
Short Release Voltage	V_{SCR}	Measured at LAX	–	–	1.9	V
Short Release Voltage Hysteresis	V_{SCHys}	$V_{SCR} - V_{SCD}$	200	–	500	mV
Thermal Monitor Activation Temperature	T_{JM}	T_J with $I_{SEN} = 90\%$, THTH open	95	115	130	$^\circ\text{C}$
Thermal Monitor Slope	dl_{SEN}/dT_J	$I_{SEN} = 50\%$, THTH open	–3.5	–2.5	–1.5	%/ $^\circ\text{C}$
Thermal Monitor Low Current Temperature	T_{JL}	T_J at $I_{SEN} = 25\%$, THTH open	120	135	150	$^\circ\text{C}$
Overtemperature Shutdown	T_{JF}	Temperature increasing	–	170	–	$^\circ\text{C}$
Overtemperature Hysteresis	T_{Jhys}	Recovery = $T_{JF} - T_{Jhys}$	–	15	–	$^\circ\text{C}$

¹For input and output current specifications, negative current is defined as coming out of (sourcing) the specified device pin.²Function is correct but parameters are not guaranteed outside the general limits (7 to 40 V).³When EN = high, $E_{ILAX} = 100 \times [(| I_{LAX} | \times R_{REF} / 15) - 1]$, with I_{LAX} in mA and R_{REF} in k Ω .⁴ $E_{IMLA} = 100 \times [\max (| I_{LAX} - I_{LA(AV)} |) / I_{LA(AV)}]$, where $I_{LA(AV)}$ is the average current of all active outputs.

Functional Description

The A6262 is a linear current regulator that is designed to provide drive current and protection for parallel strings of series-connected high brightness LEDs in automotive applications. It provides up to four matched programmable current outputs at up to 100 mA, with low minimum dropout voltages below the main supply voltage. For 12 V power net applications, optimum performance is achieved when driving 4 strings of 1 to 3 LEDs, at current up to 100 mA per string.

The A6262 is specifically designed for use in internal illumination applications where the LED activity is controlled by a PWM signal, by a logic signal, or by a push-to-make, ground-connected switch.

Current regulation is maintained and the LEDs protected during a short to ground at any point in the LED string. A short to ground on any regulator output terminal will disable that output until the short is removed. Open load on any output will be ignored.

Integrated thermal management reduces the regulated current level at high internal junction temperatures to limit power dissipation.

Pin Functions

VIN Supply to the control circuit and current regulators. A small value ceramic bypass capacitor, typically 100 nF, should be connected from close to this pin to the GND pin.

GND Ground reference connection. Should be connected directly to the negative supply.

EN Logic input to enable LED current output. This provides a direct on/off action and can be used for direct PWM control. The EN input overrides the SW input when EN is high. When EN transitions from high to low, SW input logic is reset to off.

SW Logic input to toggle LED current output on and off. A single push-to-make switch between SW and GND will provide push-to-make/push-to-break, on/off toggle action. The SW input is debounced by typically 30 ms and is internally pulled to typically 3 V, with approximately 100 μ A.

IREF 1.2 V reference to set current reference. Connect resistor, R_{REF} , to GND to set reference current.

THTH Sets the thermal monitor threshold, T_{JM} , where the output current starts to reduce with increasing temperature. Connecting THTH directly to GND will disable the thermal monitor function.

LA[1:4] Current source connected to the anode of the first LED in each string. Connect directly to VIN to disable the respective output. In this document “LAX” indicates any one of the outputs.

LED Current Level

The LED current is controlled by a matching linear current regulator between the VIN pin and each of the LAX outputs. The basic equation that determines the nominal output current at each LAX pin is:

Given EN = high,

$$I_{LAX} = \frac{K}{R_{REF}} \quad (1)$$

where I_{LAX} is in mA and R_{REF} is in k Ω ; K is 15.

The output current may be reduced from the set level by the thermal monitor circuit.

Conversely the reference resistors may be calculated from:

$$R_{REF} = \frac{K}{I_{LAX}} \quad (2)$$

where I_{LAX} is in mA and R_{REF} is in k Ω .

For example, where the required current is 90 mA for all four channels the resistor value will be:

$$R_{REF} = \frac{15}{90} = 167 \Omega$$

It is important to note that because the A6262 is a linear regulator, the maximum regulated current is limited by the power dissipation and the thermal management in the application. All current calculations assume adequate heatsinking for the dissipated power. Thermal management is at least as important as the electrical design in all applications. In high current high ambient temperature applications, the thermal management is the most important aspect of the systems design. The application section below provides further detail on thermal management and the associated limitations.

Operation with Fewer LED Strings or Higher Currents

The A6262 may be configured to use fewer than the maximum quantity of LED strings: by connecting outputs together for higher currents, by leaving the outputs open, or by connecting the output directly to VIN to disable the regulator for that output.

Sleep Mode

When EN is held low the A6262 will be in shutdown mode and all sections will be in a low power sleep mode. The input current will be typically less than 10 μA . This means that the complete circuit, including LEDs, may remain connected to the power supply under all conditions.

Safety Features

The circuit includes several features to ensure safe operation and to protect the LEDs and the A6262:

- The current regulators between VIN and each LAX output provide a natural current limit due to the regulation.
- Each LAX output includes a short-to-ground detector that will disable the output to limit the dissipation.
- The thermal monitor reduces the regulated current as the temperature rises.
- Thermal shutdown completely disables the outputs under extreme overtemperature conditions.

Short Circuit Detection A short to ground on any LED cathode (figure 1A) will not result in a short fault condition. The current through the remaining LEDs will remain in regulation and the LEDs will be protected. Due to the difference in the voltage drop across the LEDs, as a result of the short, the current matching in the A6262 may exceed the specified limits.

Any LAX output that is pulled below the short detect voltage (figure 1B) will disable the regulator on that output. A small current will be sourced from the disabled output to monitor the short and detect when it is removed. When the voltage at LAX rises above the short detect voltage, the regulator will be re-enabled.

A shorted LED (figure 1C) will not result in a short fault condition. The current through the remaining LEDs will remain in regulation and the LEDs will be protected. Due to the difference in the voltage drop across the LEDs, as a result of the short, the current matching in the A6262 may exceed the specified limits.

A short between LEDs in different strings (figure 1D) will not result in a short fault condition. The current through the remaining LEDs will remain in regulation and the LEDs will be protected. The current will be summed and shared by the affected strings. Current matching in the strings will then depend on the LED forward voltage differences.

Temperature Monitor A temperature monitor function, included in the A6262, reduces the LED current as the silicon junction temperature of the A6262 increases (see figure 2). By mounting the A6262 on the same thermal substrate as the LEDs, this feature can also be used to limit the dissipation of the LEDs.

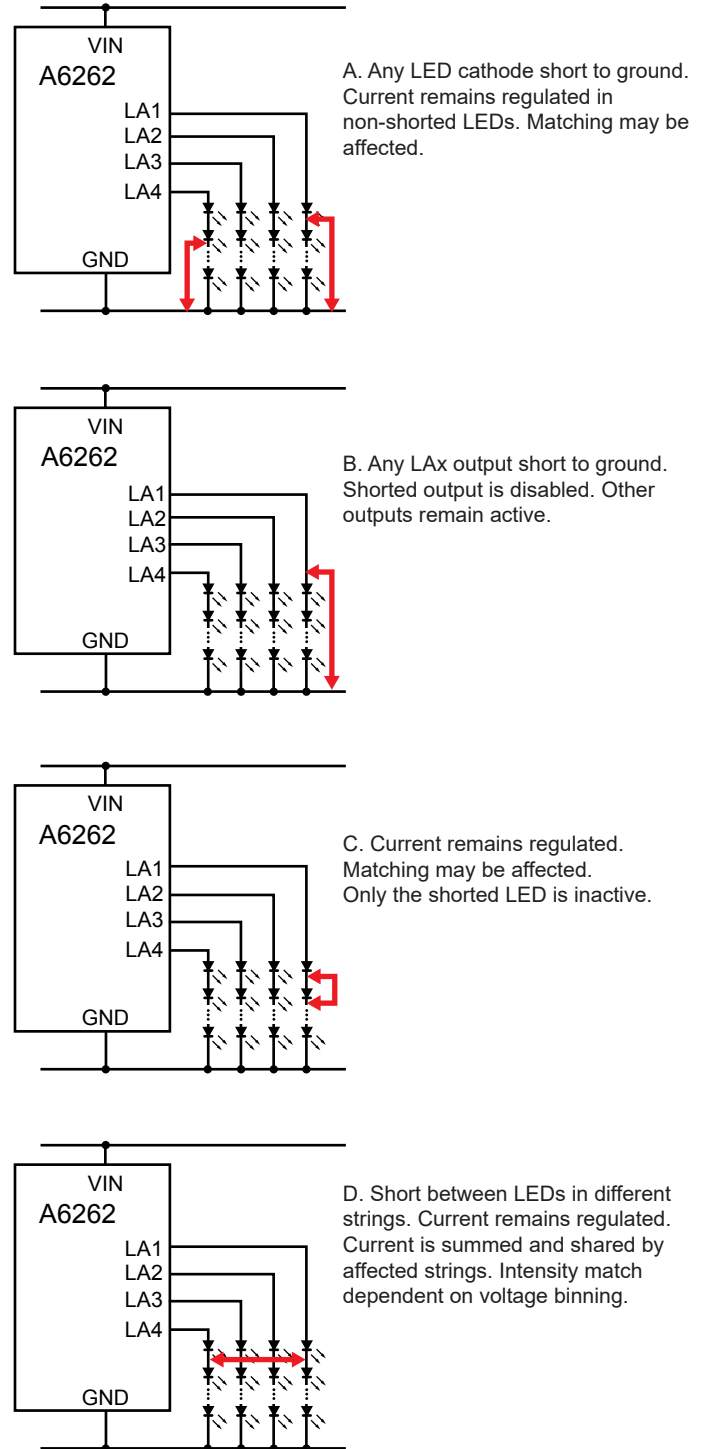

Figure 1. Short circuit conditions.

As the junction temperature of the A6262 increases, the regulated current level is reduced, reducing the dissipated power in the A6262 and in the LEDs. The current is reduced from the 100% level at typically 2.5% per degree Celsius until the point at which the current drops to 25% of the full value, defined at T_{JL} . Above this temperature, the current will continue to reduce at a lower rate until the temperature reaches the overtemperature shutdown threshold temperature, T_{JF} .

The temperature at which the current reduction begins can be adjusted by changing the voltage on the THTH pin. When THTH is left open, the temperature at which the current reduction begins is defined as the thermal monitor activation temperature, T_{JM} , and is specified, in the characteristics table, at the 90% current level.

Thermal monitor activation temperature can be set to a desired level by setting the voltage on the THTH pin (V_{THTH}). There is an internal 1 V source connected with a series resistor to the THTH pin inside the IC. A resistor connected between THTH and GND will reduce V_{THTH} and increase T_{JM} . A resistor connected between THTH and a reference supply greater than 1 V will increase V_{THTH} and reduce T_{JM} . Figure 3a shows the relationship between T_{JM} and V_{THTH} , while Figure 3b shows typical resistor values, either pull-up or pull-down, to set the voltage on THTH pin. Based on the T_{JM} requirement, the required V_{THTH} voltage can be estimated from Figure 3a; then, depending on the V_{THTH} value, the THTH pin resistor can be decided from Figure 3b. THTH pin resistor may either pull up or pull down depending on V_{THTH} . As an example, if T_{JM} of 90°C is required, then from Figure 3a, V_{THTH} should be 1.115 V. To achieve this voltage, use Figure 3b to estimate THTH pin resistor (R_{TH}). If the pull-up voltage is 5 V, then a 211 kΩ resistor should be used. If the pull-up voltage is 3 V, use a 100 kΩ resistor.

In extreme cases, if the chip temperature exceeds the overtemperature limit, T_{JF} , all regulators will be disabled. The temperature will continue to be monitored and the regulators re-activated when the temperature drops below the threshold provided by the specified hysteresis.

Note that it is possible for the A6262 to transition rapidly between thermal shutdown and normal operation. This can happen if the thermal mass attached to the exposed thermal pad is small and T_{JM} is increased to close to the shutdown temperature. The period of oscillation will depend on T_{JM} , the dissipated power, the thermal mass of any heatsink present, and the ambient temperature.

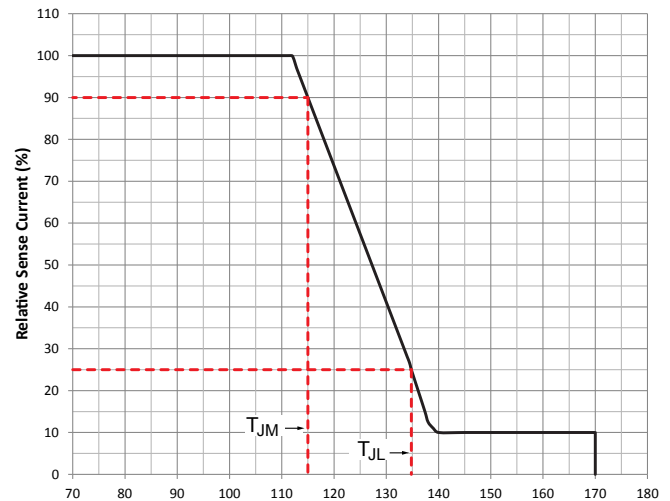

Figure 2. Temperature monitor current reduction.

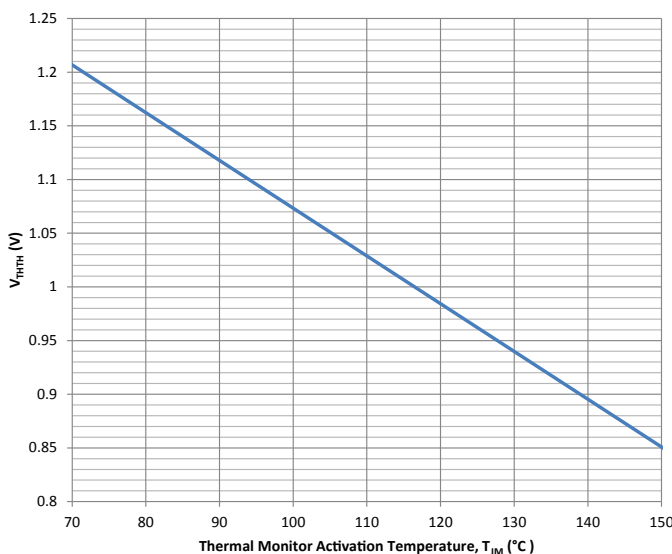

Figure 3a. Relationship between T_{JM} and V_{THTH} .

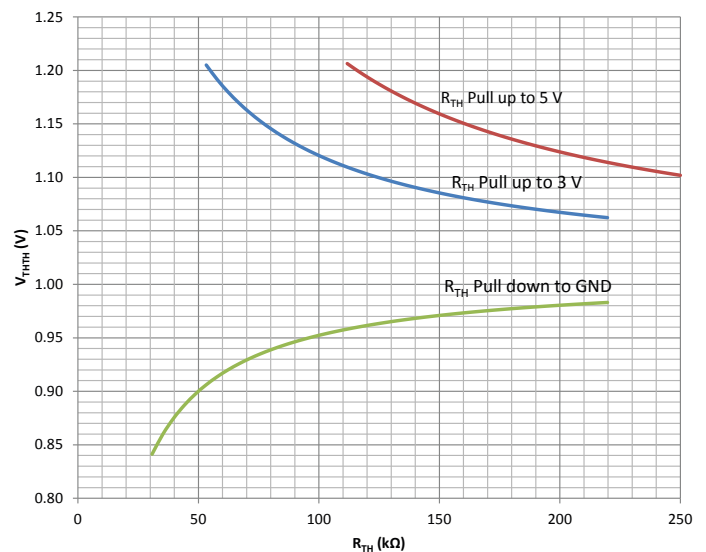

Figure 3b. Typical Resistor Values to Set Voltage on THTH Pin.

Application Information

Power Dissipation

The most critical design considerations when using a linear regulator such as the A6262 are the power produced internally as heat and the rate at which that heat can be dissipated.

There are three sources of power dissipation in the A6262:

- The quiescent power to run the control circuits
- The power in the reference circuit
- The power due to the regulator voltage drop

The elements relating to these dissipation sources are illustrated in figure 4.

Quiescent Power The quiescent power is the product of the quiescent current, I_{INQ} , and the supply voltage, V_{IN} , and is not related to the regulated current. The quiescent power, P_Q , is therefore defined as:

$$P_Q = V_{IN} \times I_{INQ} \quad (3)$$

Reference Power The reference circuit draws the reference current from the supply and passes it through the reference resistor to ground. The reference current is 8% of the output current on any one active output. The reference circuit power is the product of the reference current and the difference between the supply voltage and the reference voltage, typically 1.2 V. The reference power, P_{REF} , is therefore defined as:

$$P_{REF} = \frac{(V_{IN} - V_{REF}) \times V_{REF}}{R_{REF}} \quad (4)$$

Regulator Power In most application circuits the largest dissipation will be produced by the output current regulators. The power dissipated in each current regulator is simply the product of the output current and the voltage drop across the regulator.

The total current regulator dissipation is the sum of the dissipation in each output regulator. The regulator power for each output is defined as:

$$P_{REGx} = (V_{IN} - V_{LEDx}) \times I_{LEDx} \quad (5)$$

where x is 1, 2, 3, or 4.

Note that the voltage drop across the regulator, V_{REG} , is always greater than the specified minimum drop-out voltage, V_{DO} . The output current is regulated by making this voltage large enough to provide the voltage drop from the supply voltage to the total forward voltage of all LEDs in series, V_{LED} .

The total power dissipated in the A6262 is the sum of the quiescent power, the reference power, and the power in each of the our regulators:

$$P_{DIS} = P_Q + P_{REF} + P_{REGA} + P_{REGB} + P_{REGC} + P_{REGD} \quad (6)$$

The power that is dissipated in each string of LEDs is:

$$P_{LEDx} = V_{LEDx} \times I_{LEDx} \quad (7)$$

where x is A, B, C, or D, and V_{LEDx} is the voltage across all LEDs in the string.

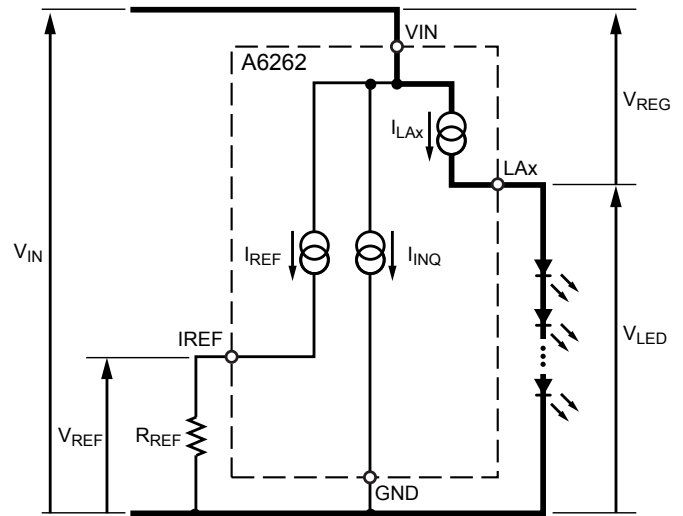

Figure 4. Internal power dissipation sources.

From these equations (and as illustrated in figure 5) it can be seen that, if the power in the A6262 is not limited, then it will increase as the supply voltage increases but the power in the LEDs will remain constant.

Dissipation Limits

There are two features limiting the power that can be dissipated by the A6262: thermal shutdown and thermal foldback.

Thermal Shutdown If the thermal foldback feature is disabled by connecting the THTH pin to GND, or if the thermal resistance from the A6262 to the ambient environment is high, then the silicon temperature will rise to the thermal shutdown threshold and the current will be disabled. After the current is disabled the power dissipated will drop and the temperature will fall. When the temperature falls by the hysteresis of the thermal shutdown circuit, then the current will be re-enabled and the temperature will start to rise again. This cycle will repeat continuously until the ambient temperature drops or the A6262 is switched off. The period of this thermal shutdown cycle will depend on several electrical, mechanical, and thermal parameters, and could be from a few milliseconds to a few seconds.

Thermal Foldback If there is a good thermal connection to the A6262, then the thermal foldback feature will have time to act. This will limit the silicon temperature by reducing the regulated current and therefore the dissipation.

The thermal monitor will reduce the LED current as the temperature of the A6262 increases above the thermal monitor activation temperature, T_{JM} , as shown in figure 6. The figure shows the

operation of the A6262 with 4 strings of 3 red LEDs, each string running at 50 mA. The forward voltage of each LED is 2.3 V and the graph shows the current as the supply voltage increases from 14 to 17 V. As the supply voltage increases, without the thermal foldback feature, the current would remain at 50 mA, as shown by the dashed line. The solid line shows the resulting current decrease as the thermal foldback feature acts.

If the thermal foldback feature did not affect LED current, the current would increase the power dissipation and therefore the silicon temperature. The thermal foldback feature reduces power in the A6262 in order to limit the temperature increase, as shown in figure 7. The figure shows the operation of the A6262 under the same conditions as figure 6. That is, 4 strings of 3 red LEDs, each string running at 50 mA with each LED forward voltage at

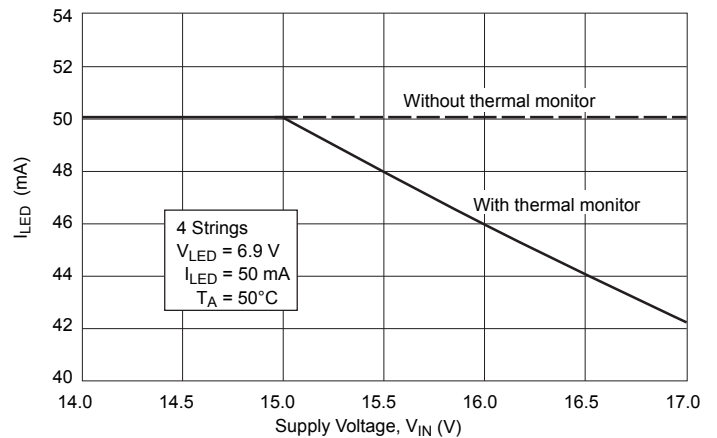

Figure 6. LED current versus Supply Voltage

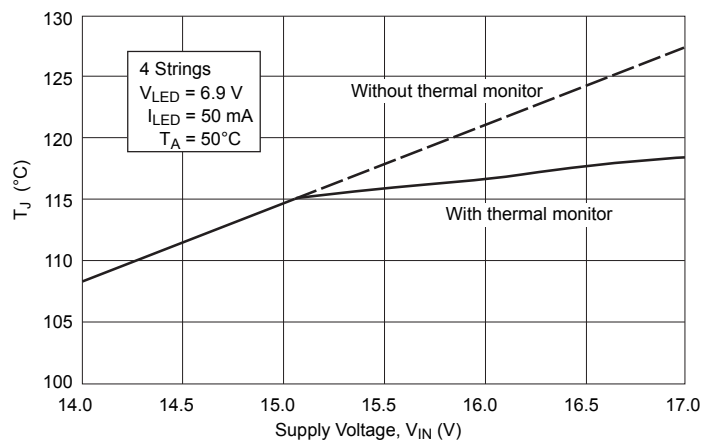

Figure 7. Junction Temperature versus Supply Voltage

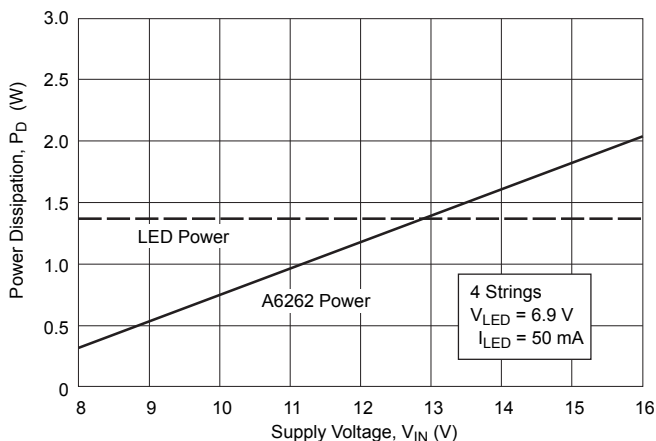

Figure 5. Power Dissipation versus Supply Voltage

2.3 V. The graph shows the temperature as the supply voltage increases from 14 to 17 V. Without the thermal foldback feature the temperature would continue to increase up to the thermal shutdown temperature as shown by the dashed line. The solid line shows the effect of the thermal foldback function in limiting the temperature rise.

Figures 6 and 7 show the thermal effects where the thermal resistance from the silicon to the ambient temperature is 40°C/W. Thermal performance can be enhanced further by using a significant amount of thermal vias as described below.

Thermal Dissipation

The amount of heat that can pass from the silicon of the A6262 to the surrounding ambient environment depends on the thermal resistance of the structures connected to the A6262. The thermal resistance, $R_{\theta JA}$, is a measure of the temperature rise created by power dissipation and is usually measured in degrees Celsius per watt (°C/W).

The temperature rise, ΔT , is calculated from the power dissipated, P_D , and the thermal resistance, $R_{\theta JA}$, as:

$$\Delta T = P_D \times R_{\theta JA} \quad (8)$$

A thermal resistance from silicon to ambient, $R_{\theta JA}$, of approximately 30°C/W (LP package) or 34°C/W (LY package) can be achieved by mounting the A6262 on a standard FR4 double-sided printed circuit board (PCB) with a copper area of a few square inches on each side of the board under the A6262. Multiple thermal vias, as shown in figure 8, help to conduct the heat from the exposed pad of the A6262 to the copper on each side of the board. The thermal resistance can be reduced by using a metal substrate or by adding a heatsink.

Supply Voltage Limits

In many applications, especially in automotive systems, the available supply voltage can vary over a two-to-one range, or greater when double battery or load dump conditions are taken into consideration. In such systems it is necessary to design the application circuit such that the system meets the required performance targets over a specified voltage range.

To determine this range when using the A6262 there are two limiting conditions:

- For maximum supply voltage the limiting factor is the power that can be dissipated from the regulator without exceeding the temperature at which the thermal foldback starts to reduce the output current below an acceptable level.

- For minimum supply voltage the limiting factor is the maximum drop-out voltage of the regulator, where the difference between the load voltage and the supply is insufficient for the regulator to maintain control over the output current.

Minimum Supply Limit: Regulator Saturation Voltage

The supply voltage, V_{IN} , is always the sum of the voltage drop across the high-side regulator, V_{REG} , and the forward voltage of the LEDs in the string, V_{LED} , as shown in figure 4.

V_{LED} is constant for a given current and does not vary with supply voltage. Therefore V_{REG} provides the variable difference between V_{LED} and V_{IN} . V_{REG} has a minimum value below which the regulator can no longer be guaranteed to maintain the output current within the specified accuracy. This level is defined as the regulator drop-out voltage, V_{DO} .

The minimum supply voltage, below which the LED current does not meet the specified accuracy, is therefore determined by the sum of the minimum drop-out voltage, V_{DO} , and the forward voltage of the LEDs in the string, V_{LED} . The supply voltage must

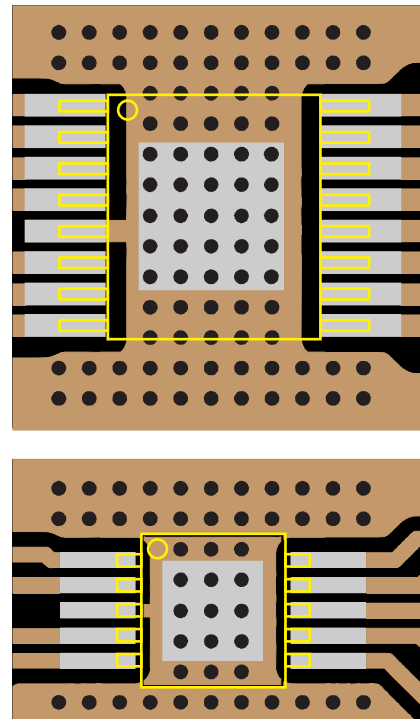

Figure 8. Board via layout for thermal dissipation: (top) LP package and (bottom) LY package.

always be greater than this value and the minimum specified supply voltage, that is:

$$\begin{aligned} V_{IN} &> V_{DO} + V_{LED}, \text{ and} \\ V_{IN} &> V_{IN(\min)} \end{aligned} \quad (9)$$

As an example, consider the configuration used in figures 6 and 7 above, namely 4 strings of 3 red LEDs, each string running at 50 mA, with each LED forward voltage at 2.3 V. The minimum supply voltage will be approximately:

$$V_{IN(\min)} = 0.55 + (3 \times 2.3) = 7.45 \text{ V}$$

Maximum Supply Limit: Thermal Limitation As described above, when the thermal monitor reaches the activation temperature, T_{JM} (due to increased power dissipation as the supply voltage rises), the thermal foldback feature causes the output current to decrease. The maximum supply voltage is therefore defined as the voltage above which the LED current drops below the acceptable minimum.

This can be estimated by determining the maximum power that can be dissipated before the internal (junction) temperature of the A6262 reaches T_{JM} .

Note that, if the thermal monitor circuit is disabled (by connecting the THTH pin to GND), then the maximum supply limit will be the specified maximum continuous operating temperature, 150°C.

The maximum power dissipation is therefore defined as:

$$P_D(\max) = \frac{\Delta T(\max)}{R_{\theta JA}} \quad (10)$$

where $\Delta T(\max)$ is difference between the thermal monitor activation temperature, T_{JM} , of the A6262 and the maximum ambient temperature, $T_A(\max)$, and $R_{\theta JA}$ is the thermal resistance from the internal junctions in the silicon to the ambient environment. If minimum LED current is not a critical factor, then the maximum voltage is simply the absolute maximum specified in the parameter tables above.

Application Examples

Operation with High-Side PWM Supply In some filament bulb replacement applications the supply may be provided by a PWM-driven high-side switch. The A6262 can be used in this application by simply connecting EN to VIN.

The toggle action of the SW input will be reset to off at each power-up. In addition, in all cases when EN is high, the EN input will override the SW toggle status and enable the outputs. At the high-to-low transition of EN, the SW toggle will always be reset to the off state.

When power is applied, there will be a short startup delay, t_{ON} , before the current starts to rise. The rise time of the current will be limited by the internal current slew rate control.

Figures 9a to 9c show application circuit options, including a higher voltage supply, and combinations of outputs tied together and disabled.

Operation with both EN and SW In some applications it may be required to utilize the functionality of both the EN input and the SW input. For example, in dome lighting, where a manual switch may be used to turn the light on and the lighting control unit may dim the light to off (see figure 10). In these cases, it is important to understand the interaction of the two control inputs.

- In all cases, when EN is high the EN input will override the SW toggle status and enable the outputs.
- When EN is low the SW input can be used to toggle the outputs on and off.
- The only time there is any interaction between the EN input and the SW toggle is the high-to-low transition of EN, where the SW toggle will always be reset to the off state.
- The SW toggle will also be reset to the off state at power-up.

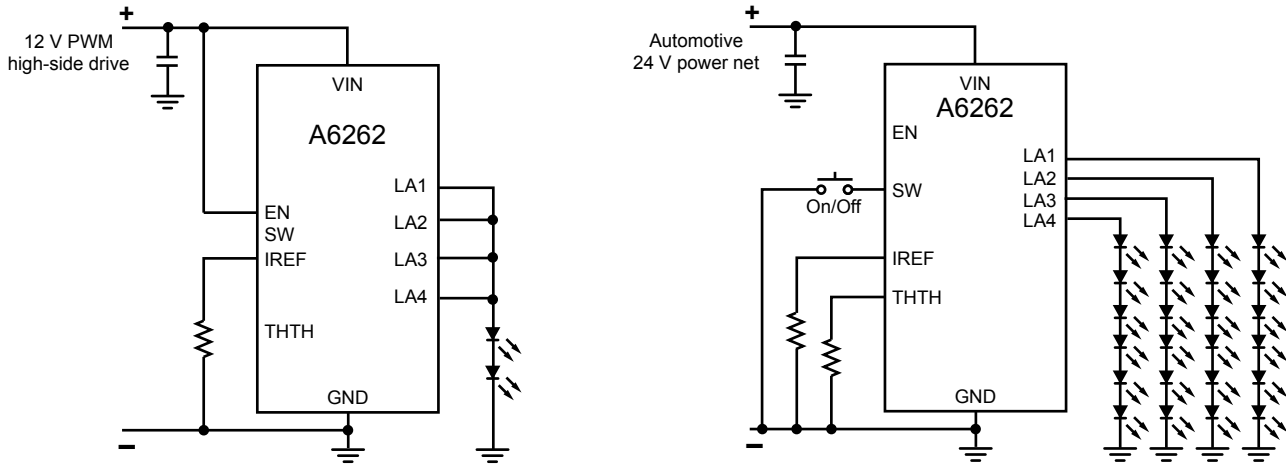

A. High brightness (HB) LED incandescent lamp replacement

B. Higher voltage operation

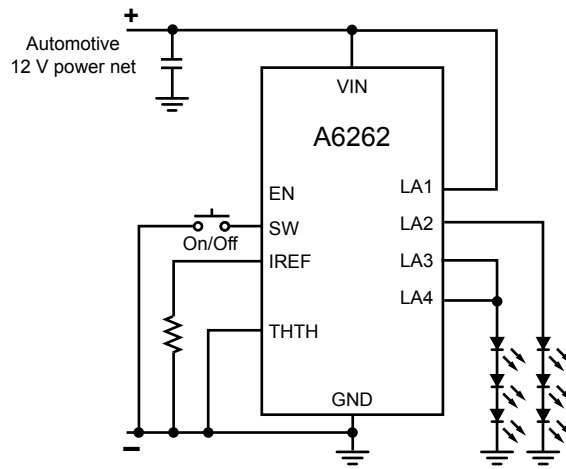

C. Mix of output combinations

Figure 9. Typical applications with various supply and output options.

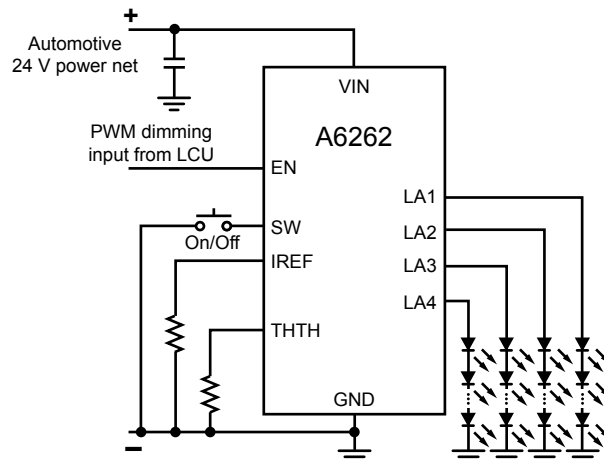

Figure 10. Typical applications using SW and EN together

Binning Resistor Arrangement

An external binning resistor can be connected in series with the IREF pin to set appropriate current through various LED batches. A filter capacitor of 100 nF should be placed after R_{REF1} as shown in Figure 11.

$$I_{LAX}(\min) = (K) \div (R_{REF1} + R_{REF2}) \quad (11)$$

$$I_{LAX}(\max) = (K) \div R_{REF1} \quad (12)$$

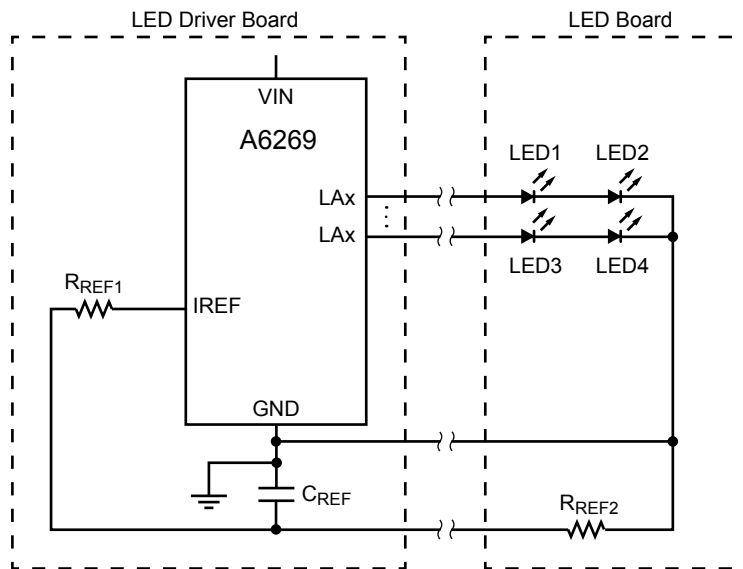

Figure 11. Application Circuit for Binning – Current-setting resistor (R_{REF2}) can be placed on LED board for different bins of LEDs

Package LP, 16-Pin TSSOP with Exposed Thermal Pad

For Reference Only – Not for Tooling Use

(Reference JEDEC MO-153 ABT; Allegro DWG-0000379, Rev. 3)

Dimensions in millimeters – NOT TO SCALE

Dimensions exclusive of mold flash, gate burrs, and dambar protrusions
Exact case and lead configuration at supplier discretion within limits shown

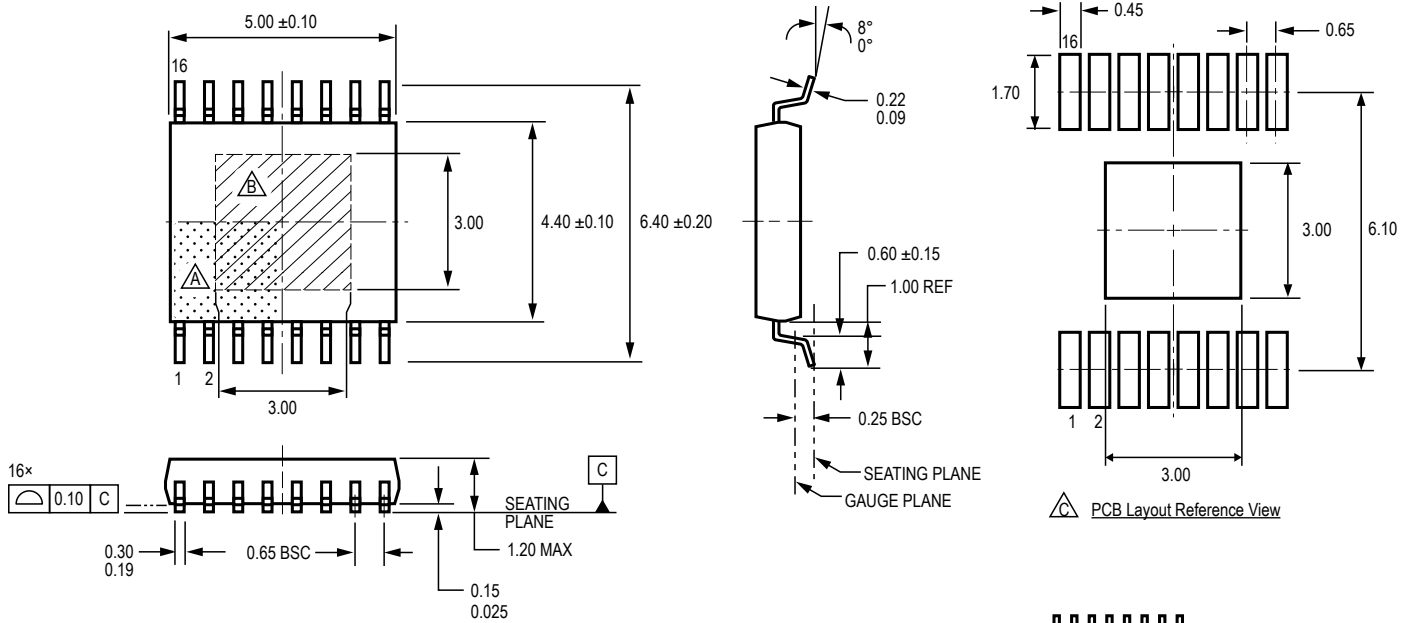

- A** Terminal #1 mark area
- B** Exposed thermal pad (bottom surface)
- C** Reference land pattern layout (reference IPC7351 SOP65P640X110-17M); All pads a minimum of 0.20 mm from all adjacent pads; adjust as necessary to meet application process requirements and PCB layout tolerances; when mounting on a multilayer PCB, thermal vias at the exposed thermal pad land can improve thermal dissipation (reference EIA/JEDEC Standard JESD51-5)
- D** Branding scale and appearance at supplier discretion

- D** Standard Branding Reference View
- Line 1, 2 = 7 characters
Line 3 = 5 characters

Line 1: Part Number
Line 2: Logo A, 4 digit Date Code
Line 3: Characters 5, 6, 7, 8 of Assembly Lot Number

Package LY, 10-Pin MSOP with Exposed Thermal Pad

For Reference Only – Not for Tooling Use

(Reference Allegro DWG-0000390, Rev. 2 and JEDEC MO-187)
 Dimensions in millimeters – NOT TO SCALE
 Dimensions exclusive of mold flash, gate burrs, and dambar protrusions
 Exact case and lead configuration at supplier discretion within limits shown

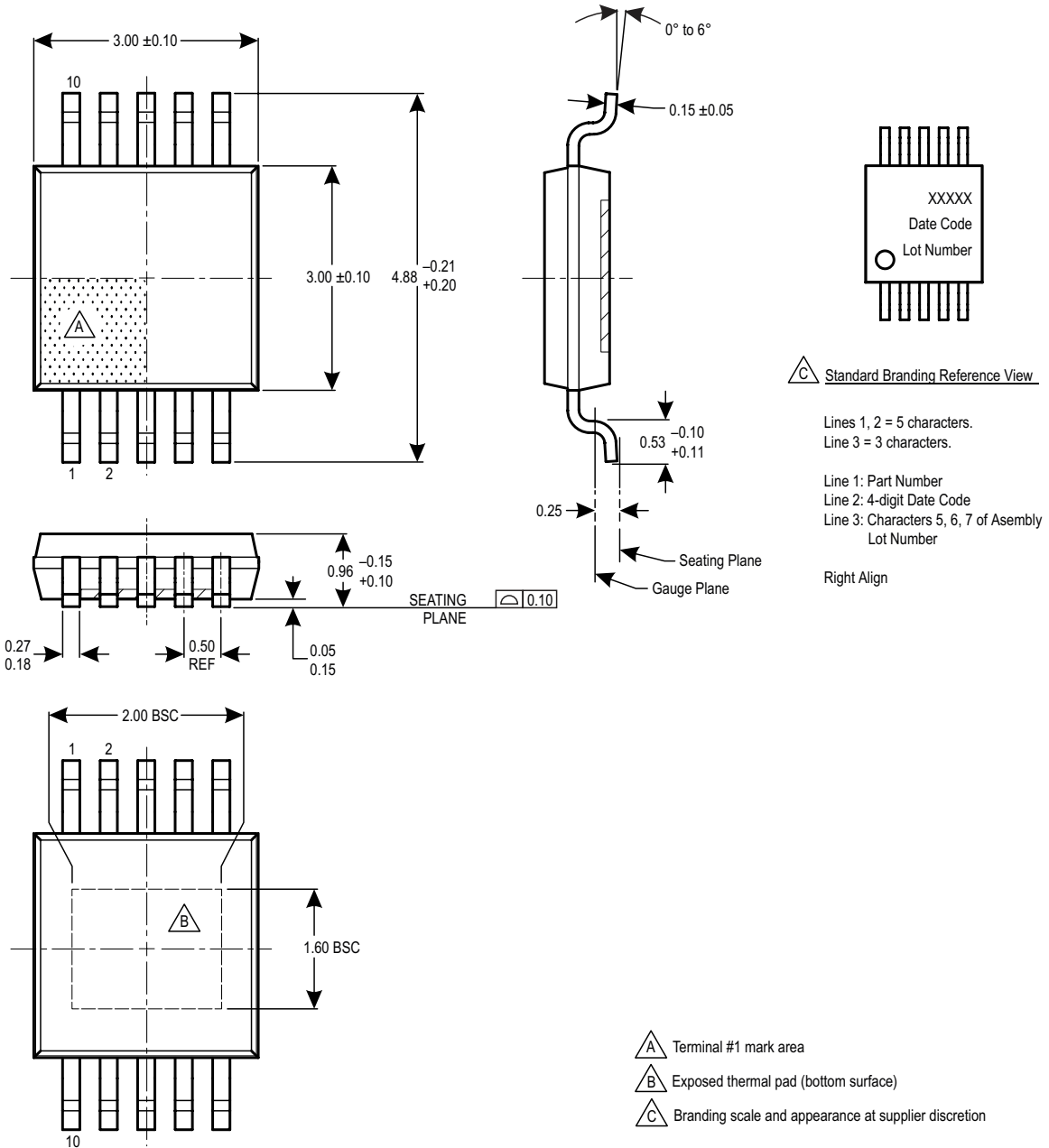

Revision History

Number	Date	Description
6	June 24, 2013	Update Features List, figure 5
7	June 25, 2015	Temperature Monitor text on page 7 updated to match EC table: derating slope is -2.5% per °C
8	July 26, 2016	Revised Temperature Monitor section (page 7) and added Binning Resistor Arrangement section (page 13)
9	May 28, 2020	Minor editorial updates
10	June 3, 2022	Updated package drawings (pages 14-15)

Copyright 2022, Allegro MicroSystems.

Allegro MicroSystems reserves the right to make, from time to time, such departures from the detail specifications as may be required to permit improvements in the performance, reliability, or manufacturability of its products. Before placing an order, the user is cautioned to verify that the information being relied upon is current.

Allegro's products are not to be used in any devices or systems, including but not limited to life support devices or systems, in which a failure of Allegro's product can reasonably be expected to cause bodily harm.

The information included herein is believed to be accurate and reliable. However, Allegro MicroSystems assumes no responsibility for its use; nor for any infringement of patents or other rights of third parties which may result from its use.

Copies of this document are considered uncontrolled documents.

For the latest version of this document, visit our website:

www.allegromicro.com