

LOC	DIST	P	F	ZONE	LTR	DESCRIPTION	DATE	APPD
DF	50				J	REV PER 0H14-0120-03 CT	10-26-04	DE

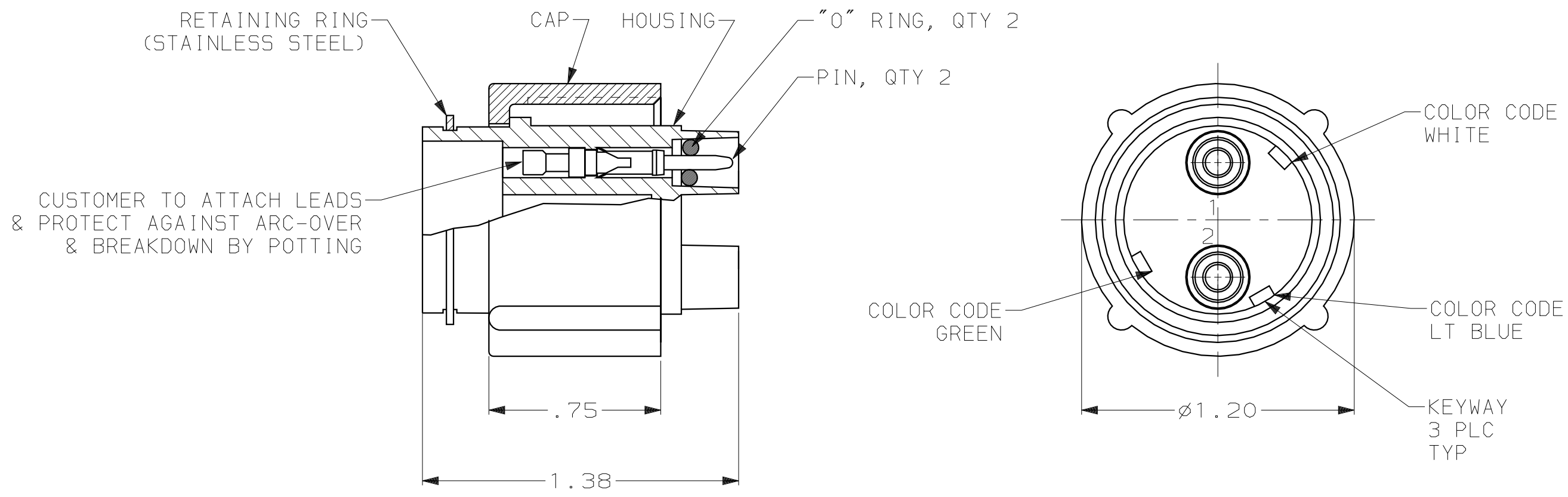

1. PLUG ASS'Y WILL WITHSTAND WITHOUT BREAKDOWN 27 KVDC PIN TO PIN & 27 KVDC PIN TO GROUND WHEN MATED WITH RECEPT.
- 2 TYPE II PINS TO ACCEPT (1) 20 AWG, (1) 22 AWG, OR (1) 24 AWG STRANDED WIRE.
- 3 TYPE II PINS TO ACCEPT (1) 16 AWG OR (1) 18 AWG STRANDED WIRE.
- 4 TYPE II PINS TO ACCEPT (1) 14 AWG STRANDED WIRE.
5. PLUGS AND PINS TO BE PACKAGED SEPARATELY.
6. TO REMOVE PINS USE EXTRACTION TOOL #861751-1.

OBS	REMARKS	HAND TOOL	COLOR CODE	RANGE WIRE SIZE	PART NO.
	4	45098	NO	14	860261-6
	3	45098	NO	16,18	860261-5
	2	45099	NO	20,22,24	860261-4
OBS	4	45098	YES	14	860261-3
	3	45098	YES	16,18	860261-2
OBS	2	45099	YES	20,22,24	860261-1

DO NOT SCALE PRINT. UNLESS SPECIFIED DIMENSIONS IN mm [INCHES] TOLERANCES ON : 2 PLC DEC ± - 3 PLC DEC ± - ANGLES ± -	DR 07-08-93 THOMPSON CHK 07-23-93 S. GLATFELTER APPD 07-23-93 S. GLATFELTER	AMP Incorporated Harrisburg, PA 17105-3608			
MATERIAL POLYESTER	APPD 07-23-93 S. GLATFELTER PRODUCT SPEC -				
FINISH BLACK	APPLICATION SPEC -	SIZE C	CAGE CODE 00779	DRAWING NO C-860261	
	WEIGHT -	SCALE 2:1		SHEET 1 OF 1	

THIS DRAWING IS A CONTROLLED DOCUMENT FOR AMP INCORPORATED. IT IS SUBJECT TO CHANGE AND THE CONTROLLING ENGINEERING ORGANIZATION SHOULD BE CONTACTED FOR THE LATEST REVISION.