

*RoHS COMPLIANT

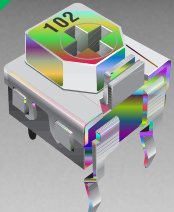

BOURNS®

Features

- Single-Turn / Carbon / Commercial Open Frame
- Cross slot rotor design suitable for automatic adjustment equipment
- Board retention features
- Enclosed cover
- PC board stand-offs
- Adjustable front / back, top / bottom
- RoHS compliant*

3318 - 6 mm Square Trimming Potentiometer

Electrical Characteristics

Standard Resistance Range100 Ω to 1 MΩ
 (see standard resistance table)
 Resistance Tolerance±20 %
 Contact Resistance Variation10 % max.
 ResolutionInfinite
 Adjustment Angle.....210 °± 15 °

Environmental Characteristics

Power Rating0.1 watt
 Temperature Range.....-10 °C to +70 °C
 Temperature Coefficient.....±1,000 PPM/°C
 Load Life240 hours @ 50 °C (+20/-5 %ΔTR)

Physical Characteristics

Torque (Operating).....20~250 gf-cm
 Stop Strength
 Knob Side800 gf-cm
 Reverse Side.....350 gf-cm
 TerminalsSolderable pins
 MarkingResistance code
 Standard Packaging500 pcs. per bag

How to Order

3318 P - 1 - 103 A

Model _____
 Style _____
 Standard or Modified Product Indicator _____
 -1 = Standard Product
 Resistance Code _____
 Ammo Pak Designator (G, S & B only) _____

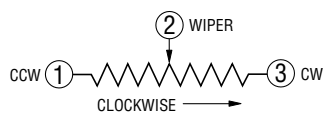

Product Dimensions

Model 3318S

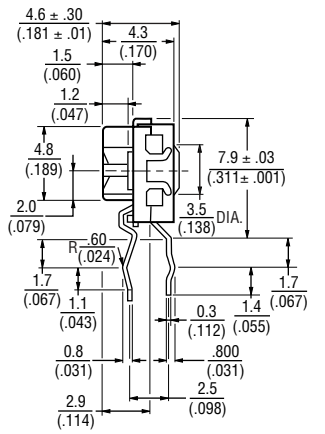
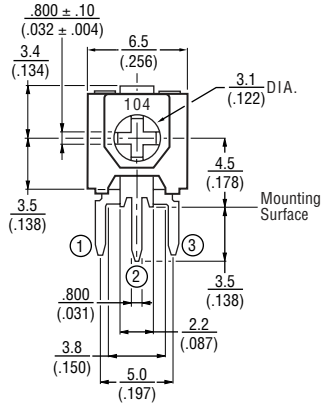

Model 3318P

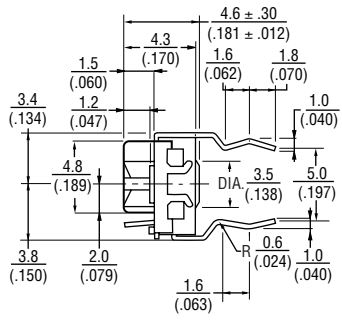
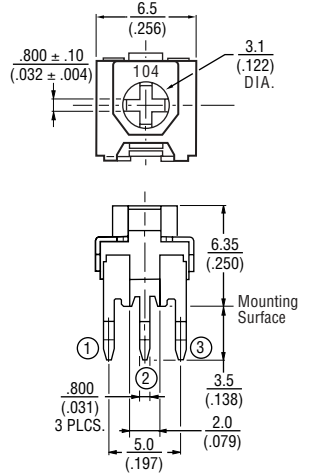

Recommended PCB Layout

Recommended PCB Layout

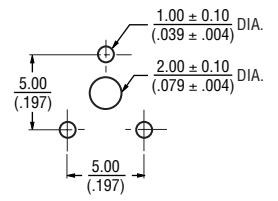
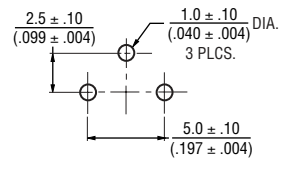

TOLERANCES: ± 0.25 (.010) EXCEPT WHERE NOTED

DIMENSIONS ARE: $\frac{\text{MM}}{\text{(INCHES)}}$

*RoHS Directive 2002/95/EC Jan 27 2003 including Annex. Specifications are subject to change without notice. Customers should verify actual device performance in their specific applications.

3318 - 6 mm Square Trimming Potentiometer

BOURNS®

Product Dimensions

Model 3318B

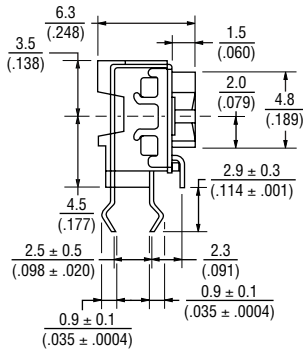
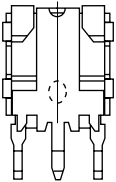
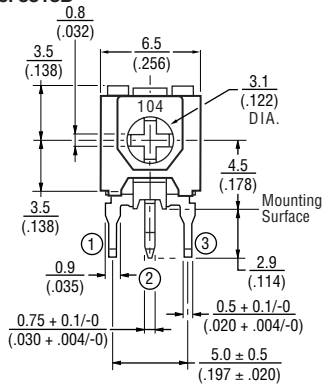

Standard Resistance Table

Resistance (Ohms)	Resistance Code	Resistance (Ohms)	Resistance Code
100	101	10,000	103
200	201	20,000	203
220	221	22,000	223
300	301	30,000	303
500	501	47,000	473
1000	102	50,000	503
2000	202	100,000	104
2200	222	200,000	204
3000	302	220,000	224
3300	332	470,000	474
4700	472	500,000	504
5000	502	100,000	105

Recommended PCB Layout

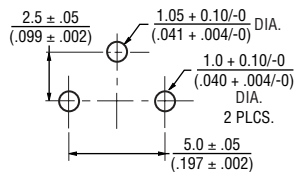

TOLERANCES: ± 0.25 (.010) EXCEPT WHERE NOTED

DIMENSIONS ARE: $\frac{\text{MM}}{\text{(INCHES)}}$

3318 - 6 mm Square Trimming Potentiometer

BOURNS®

Packaging Specifications

Ammo Pack Model 3318S

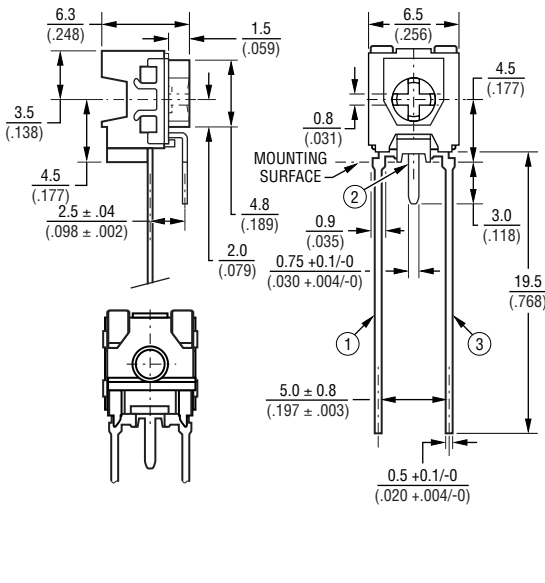

Recommended PCB Layout

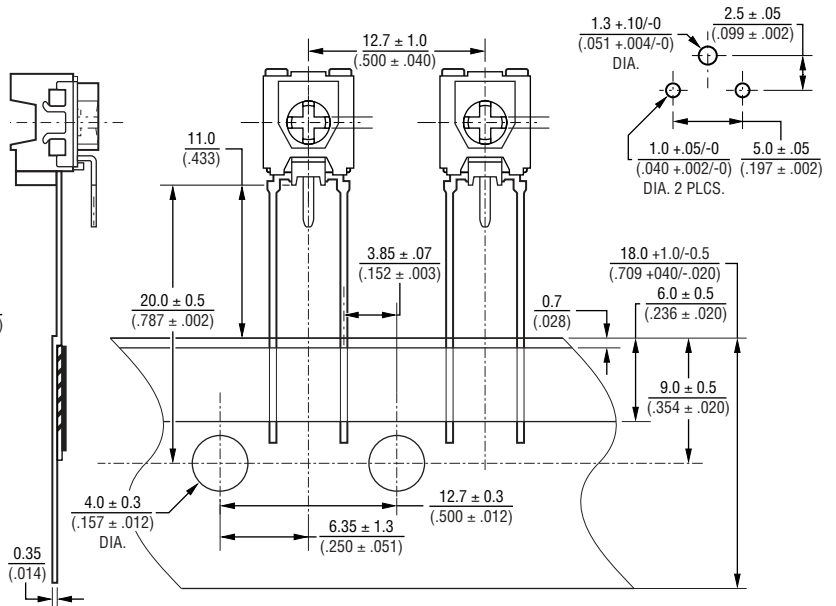

Ammo Pack Model 3318G

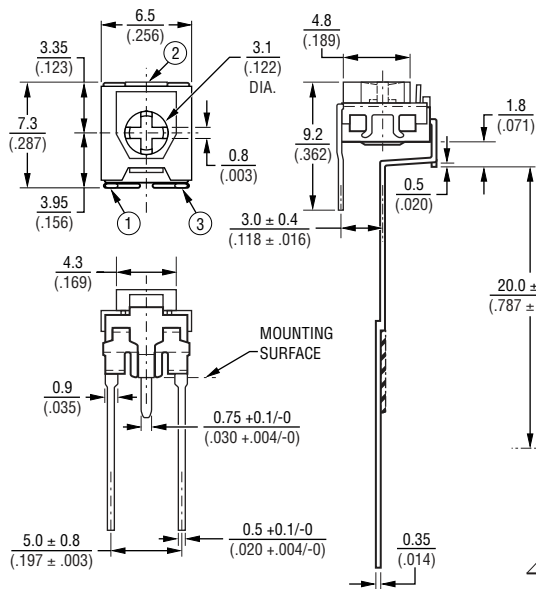

Recommended PCB Layout

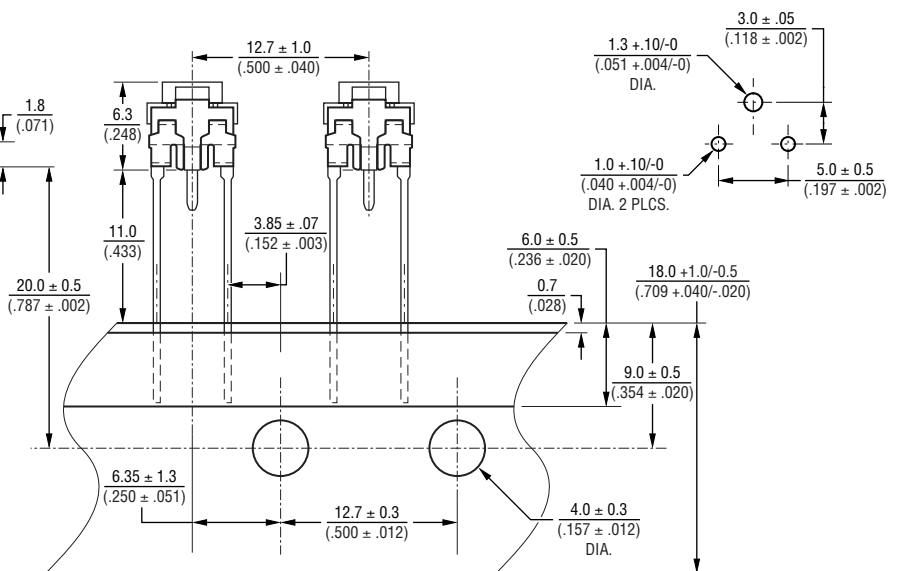

Specifications are subject to change without notice.
Customers should verify actual device performance in their specific applications.

3318 - 6 mm Square Trimming Potentiometer

BOURNS®

Packaging Specifications

Ammo Pack Model 3318B

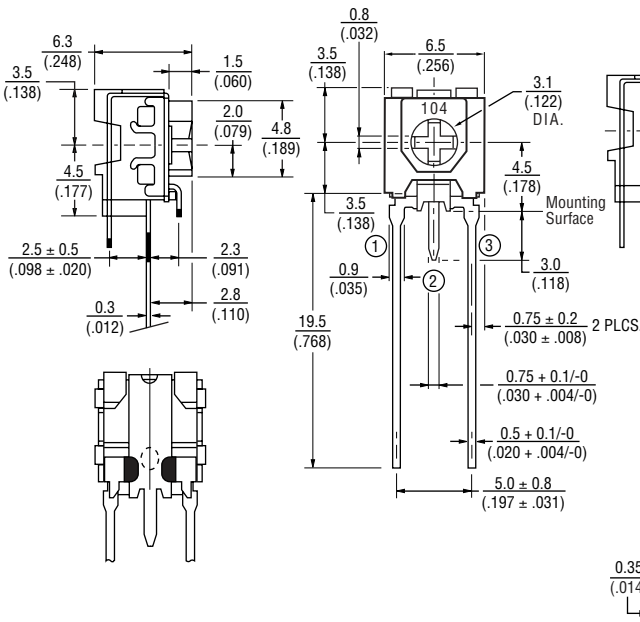

Recommended PCB Layout

