

THIS DRAWING IS UNPUBLISHED. RELEASED FOR PUBLICATION  
 © COPYRIGHT - By - ALL RIGHTS RESERVED.

LOC	DIST	REVISIONS					
AF	50	P	LTR	DESCRIPTION	DATE	DWN	APVD
			R1	REVISED PER ECR-20-009164	3AUG2020	MK	DH

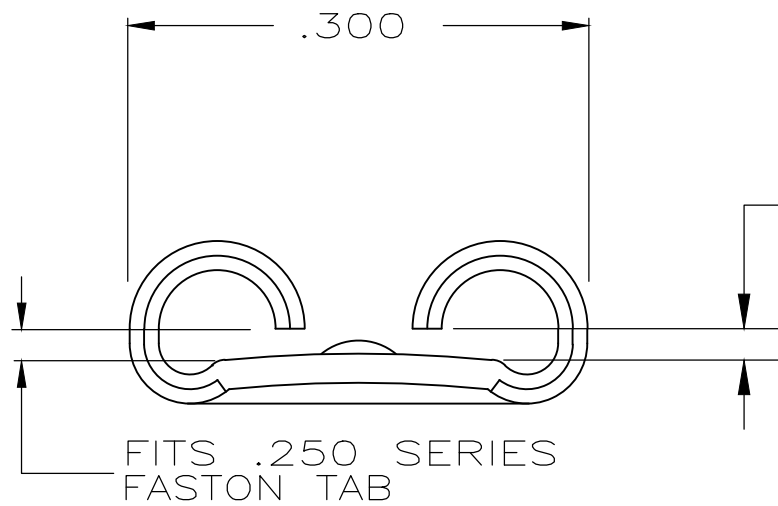

- 1 CONTINUOUS STRIP ON REELS.
- 2 STRESS RELIEVE THIS PART
- 3 THIS PART MUST MATE TO A TAB WITH A HOLE, NOT A DIMPLE.

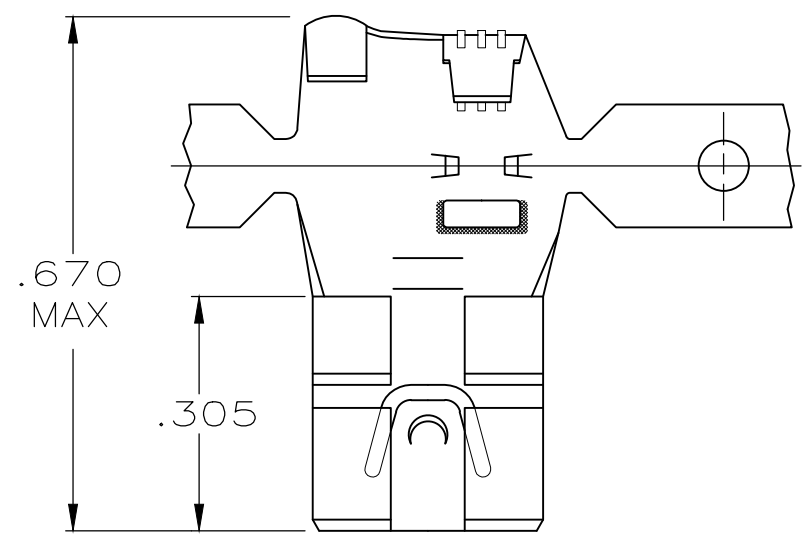
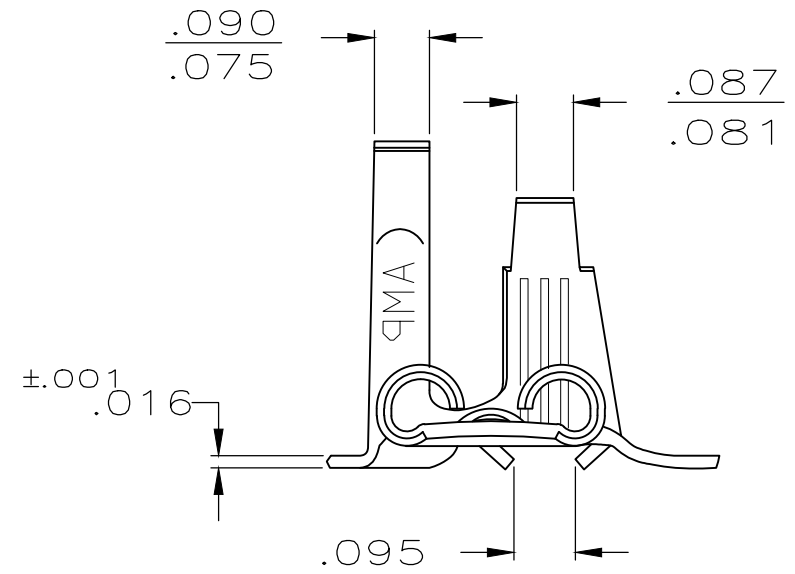

VIEW A-A

OBSOLETE	3	-	.110-.210	18-12	.033-.030	63445-5
	2	TIN	.110-.210	18-12	.033-.030	63445-4
		SILVER	.110-.210	18-12	.032	63445-3
		TIN	.110-.210	18-12	.033-.030	63445-2
		-	.110-.210	18-12	.033-.030	63445-1
	FINISH		INSULATION RANGE	WIRE SIZE	MATING TAB THK	PART NO

THIS DRAWING IS A CONTROLLED DOCUMENT.		DWN	JR RUTH	7/10/86	<b>STE</b> TE Connectivity		
DIMENSIONS: INCHES		CHK	G YETTER	7/11/86			
TOLERANCES UNLESS OTHERWISE SPECIFIED:		APVD	C MEYERS	7/11/86	NAME		
0 PLC ± -		PRODUCT SPEC			.250 SERIES FLAG FASTON RECEPTACLE		
1 PLC ± -		APPLICATION SPEC			-		
2 PLC ± -		SIZE	A3	CAGE CODE	00779	DRAWING NO	C-63445
3 PLC ± .010		WEIGHT			RESTRICTED TO		
4 PLC ± -		CUSTOMER DRAWING			-		
ANGLES ± -		SCALE			4:1		
FINISH		SHEET			1 OF 1		
BRASS		REV			R1		