

NOTES:

- 1) MATERIALS:  
HOUSING AND TAIL ALIGNER: HIGH TEMPERATURE NYLON, GLASS FILLED, UL 94V-0, BLACK.  
TERMINALS - COPPER ALLOY.  
ESD CLIP & SHIELD - COPPER ALLOY.
- 2) FINISHES:  
TERMINAL: GOLD (Au) IN THE CONTACT AREA, THICKNESS=0.76 MICROMETER (30 MICROINCH) MINIMUM, TIN (Sn) IN THE PC TAIL AREA, THICKNESS=1.90 MICROMETER (75 MICROINCH) MINIMUM, NICKEL (Ni) UNDERPLATE OVERALL.  
SHIELD: TIN (Sn); THICKNESS=3.81 MICROMETER (150 MICROINCH) MINIMUM, NICKEL (Ni) UNDERPLATE OVERALL.
- 3) CIRCUIT NUMBERS 11 THRU 14 AND 17 THRU 20 ARE ADVANCED ( LONG) TERMINAL FOR FIRST MATE/LAST BREAK OF SEQUENTIAL MATING.
- 4) CONNECTOR WILL ACCEPT MATING TO A PC BOARD CARD EDGE WITH A THICKNESS OF .062 +.005 - .007".
- 5) THE TWO .060/152 HOLES NECESSARY ONLY FOR MOLEX PART NUMBERS 74065-0001, -0002, -0005, & -0016
- 6) THE PRIMARY SHIPPING CARTON WILL BE LABELED "COMPLIANT TO RoHS DIRECTIVE 2002/95/EC AND ELV ANNEX II OF DIRECTIVE 2000/53/EC". CARTONS WITHOUT THIS LABEL MAY CONTAIN PRODUCT WITH LEAD.
- 7) CONFORMS TO MOLEX PRODUCT SPECIFICATION PS-73826-0000.
- 8) A 4 DIGIT DATE CODE (WK YR-EXAMPLE 42 98) TO BE LOCATED IN AREA SHOWN.
- 9) PRODUCT CONFORMS TO SPECIFICATIONS PER SMALL FORM FACTOR DOCUMENT FOR GIGABIT INTERFACE CONVERTER (GIBC).

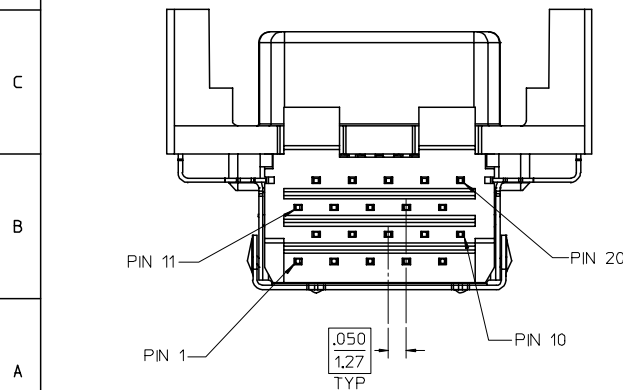
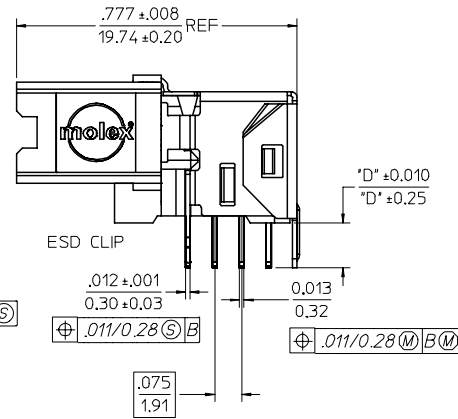
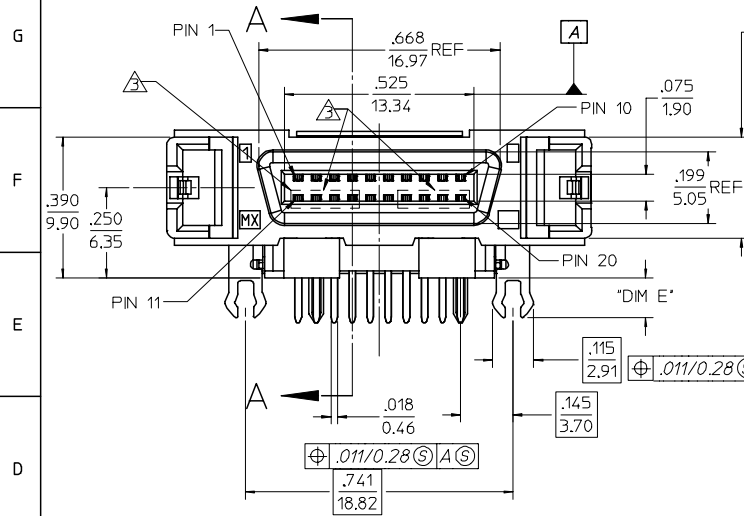
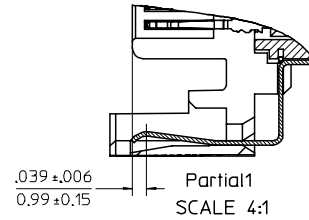
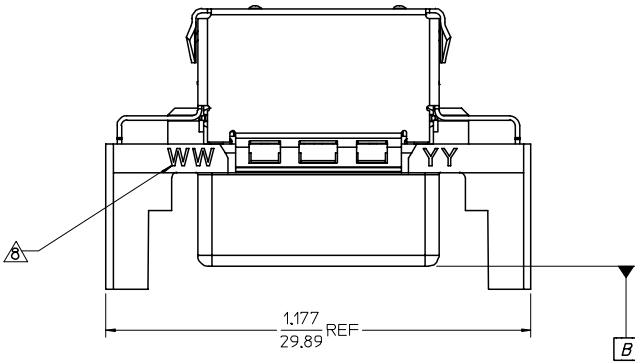

NOTE FOR LEAD FREE CONVERSION:

THE PRIMARY SHIPPING CARTON WILL BE LABELED "COMPLIANT TO RoHS DIRECTIVE 2002/95/EC AND ELV ANNEX II OF DIRECTIVE 2000/53/EC". CARTONS WITHOUT THIS LABEL MAY CONTAIN PRODUCT WITH LEAD.

PART NUMBER	DIM "D"	DIM "E"	SHIELDING OPTION	BOARD THICKNESS
74065-0001	.125	.110	SHIELDING PEG	.062 - .079
74065-0002	.150	.140	SHIELDING PEG	.080 - .110
74065-0003	.125	.110	NO PEG	.062 - .079
74065-0004	.150	.140	NO PEG	.080 - .110
74065-0005	.100	.110	SHIELDING PEG	.062 - .079
74065-0006	.100	.110	NO PEG	.062 - .079
74065-0013	.125	.110	NO PEG	.062 - .079
74065-0015	.125	.110	NO PEG	.062 - .079

REVISED PER EC NO.:UCP2004-1951 DRWN:BBARKER004/04/30 CHK: SMILLER2004/04/30 APPR:BEVAZIE2004/05/05	QUALITY SYMBOLS ▽-0 ◊-0	GENERAL TOLERANCES (UNLESS SPECIFIED)		SCALE 4:1	DESIGN UNITS INCH	THIRD ANGLE PROJECTION	REVISE ON CAD ONLY	
		mm	INCH	DIMENSION STYLE MM/IN		SALES ASMY FOR 20 KKT SCA-2 R/A SHIELDED GIBC RECEPTACLE		
		4 PLACES ± --- ± ---	3 PLACES ± --- ± 0.005	DRAWN BY HPA	DATE 12/17/98			
		2 PLACES ± 0.13 ± 0.01	1 PLACE ± 0.25 ± ---	CHECKED BY MB	DATE 12/18/98	MOLEX INCORPORATED		
ANGULAR ± 1/2 °		APPROVED BY MB	DATE 12/18/98	MATERIAL NO. SEE CHART	DOCUMENT NO. SD-74065-001			
DRAFT WHERE APPLICABLE MUST REMAIN WITHIN DIMENSIONS		THIS DRAWING CONTAINS INFORMATION THAT IS PROPRIETARY TO MOLEX INCORPORATED AND SHOULD NOT BE USED WITHOUT WRITTEN PERMISSION						

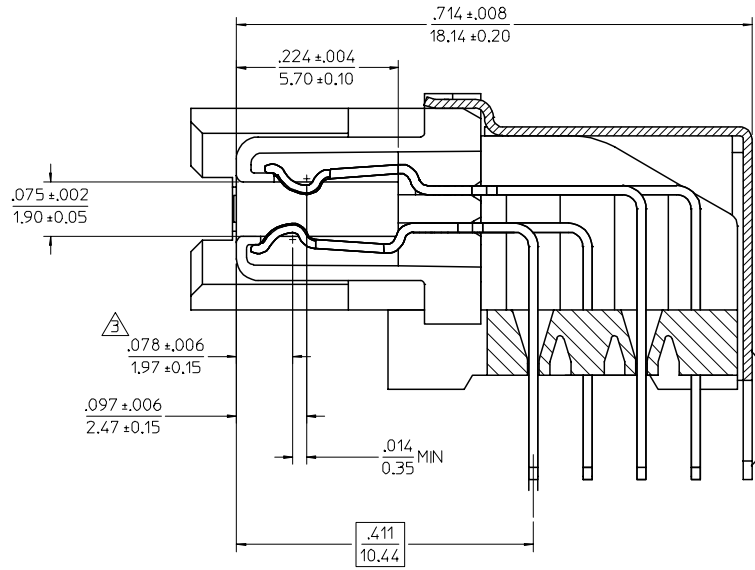

SECTION A-A

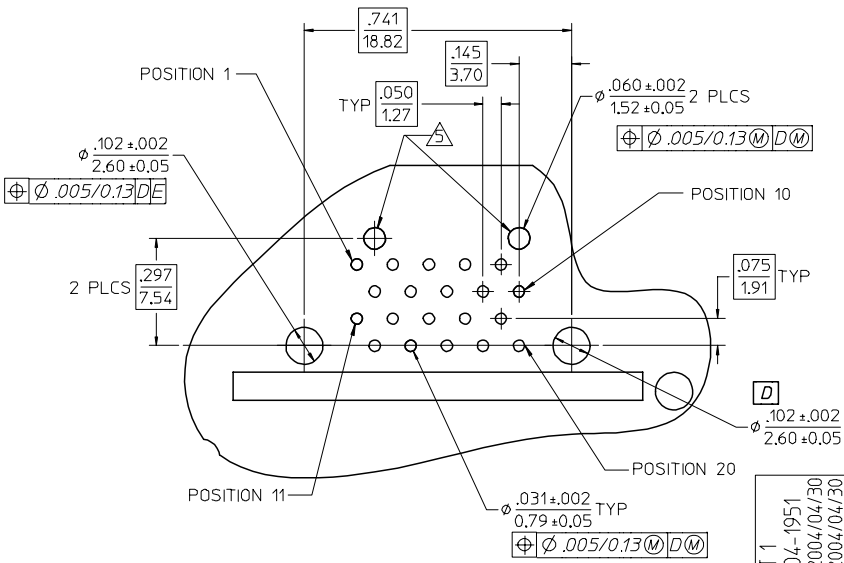

RECOMMENDED PC BOARD  
MOUNTING DIMENSIONS  
COMPONENT SIDE  
SCALE 4:1

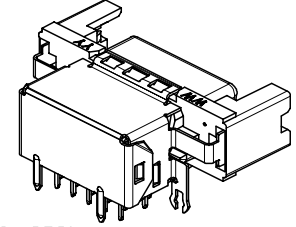
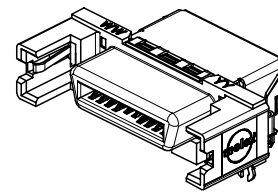

STANDARD SHIELD WITH PEGS  
74065-0001, -0002, -0005, -0016

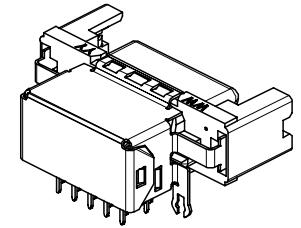
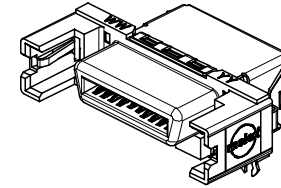

STANDARD SHIELD WITHOUT PEGS  
74065-0003, -0004, -0006

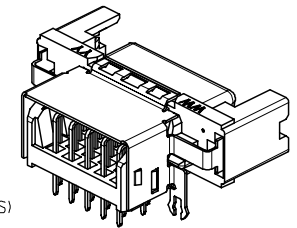
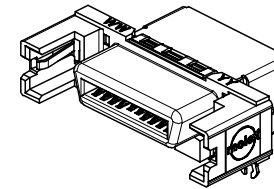

OPEN BACK SHIELD (NO PEGS)  
74065-0015

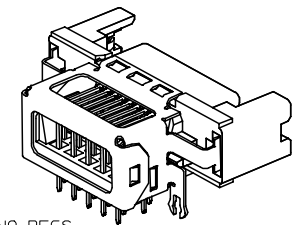
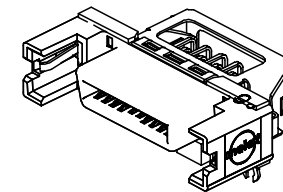

OPEN TOP SHIELD, NO PEGS  
74065-0013

REV	QUALITY SYMBOLS	GENERAL TOLERANCES (UNLESS SPECIFIED)		SCALE 8:1	DESIGN UNITS INCH	THIRD ANGLE PROJECTION	REVISE ON CAD ONLY	
	DESCRIPTION	mm	INCH	DIMENSION STYLE MM/IN		SALES ASMY FOR 20 CKT SCA-2 R/A SHIELDED GBIC RECEPTACLE		
1	SEE SHT 1	4 PLACES ±---	±---	DRAWN BY HPA	DATE 12/17/98	MOLEX INCORPORATED		
2	EC NO: UCP2004-1951	3 PLACES ±---	±0.005	CHECKED BY MB	DATE 12/18/98	MATERIAL NO. SEE CHART		
3	DRWN: BBARKER004/04/30	2 PLACES ±0.13	±0.01	APPROVED BY MB	DATE 12/18/98	DOCUMENT NO. SD-74065-001	SHEET NO. 2 OF 2	
4	CHK: SMILLER2004/04/30	1 PLACE ±0.25	±---	DRAFT WHERE APPLICABLE MUST REMAIN WITHIN DIMENSIONS		THIS DRAWING CONTAINS INFORMATION THAT IS PROPRIETARY TO MOLEX INCORPORATED AND SHOULD NOT BE USED WITHOUT WRITTEN PERMISSION		
5	APPR: BVEAZIE2004/05/05	ANGULAR ± 1/2 °						