

THIS DRAWING IS UNPUBLISHED. RELEASED FOR PUBLICATION 20
 © COPYRIGHT 20 BY - ALL RIGHTS RESERVED.

REVISIONS					
P	LTR	DESCRIPTION	DATE	DWN	APVD
A		RELEASED	05MAR2020	X.L	I.Y
A1		SEE ECR-21-000027	04JAN2021	L.G	I.Y
B		SEE ECR-21-002821	16MAR2021	L.G	I.Y
B1		ECN-21-127853	24NOV2021	L.G	Z.Z

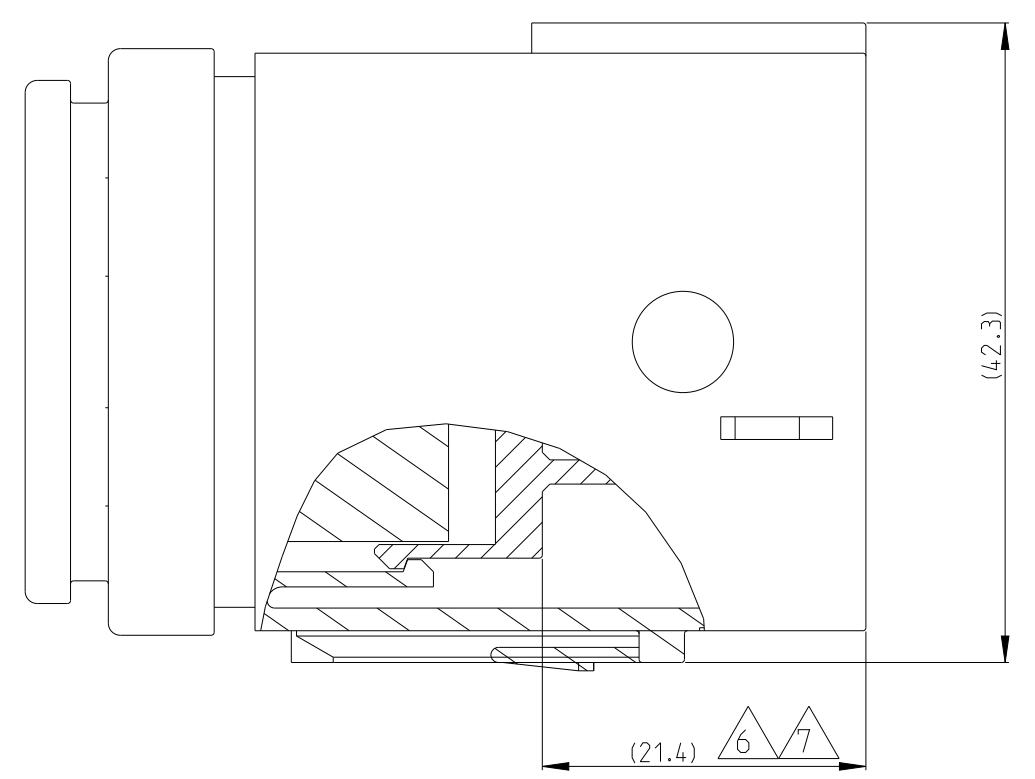
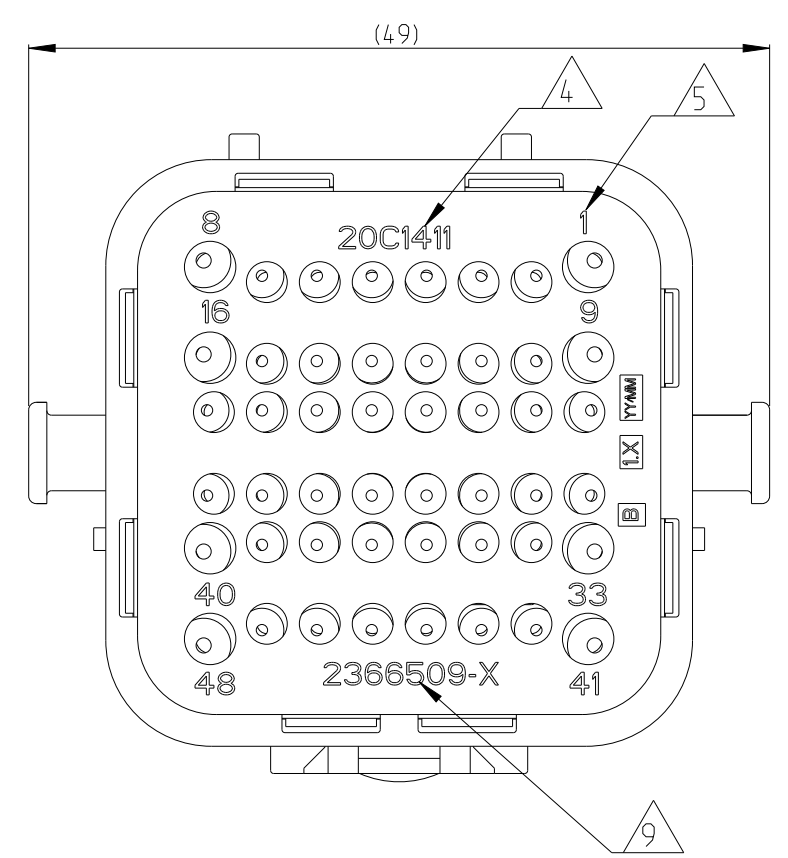
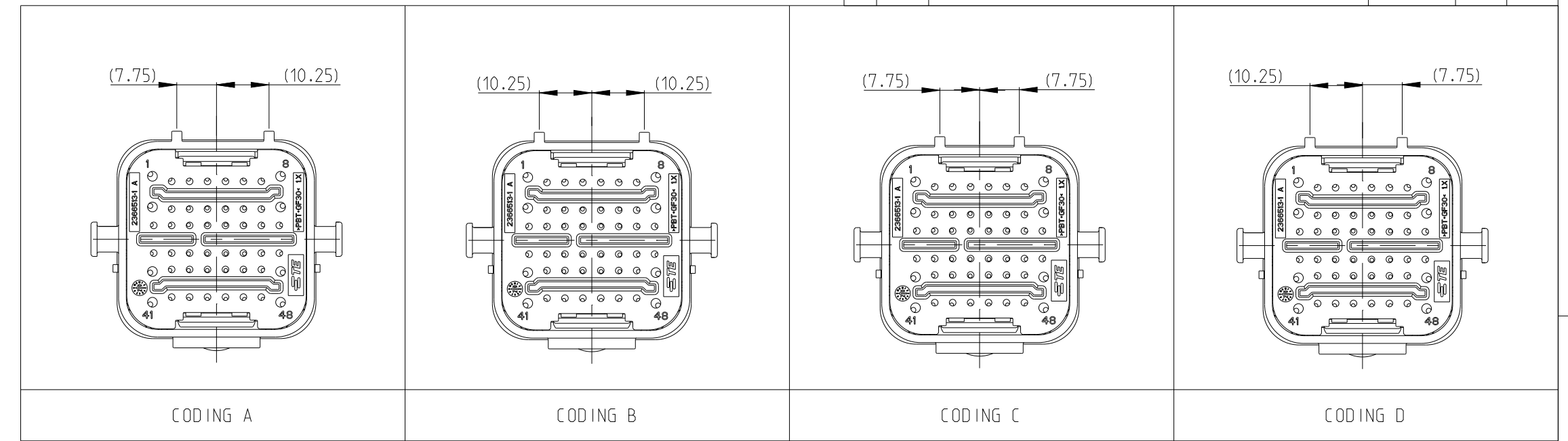
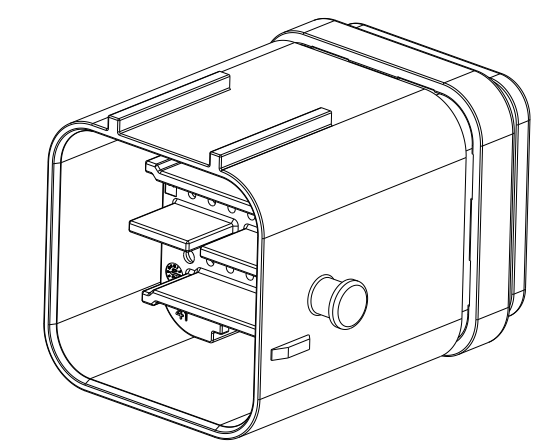
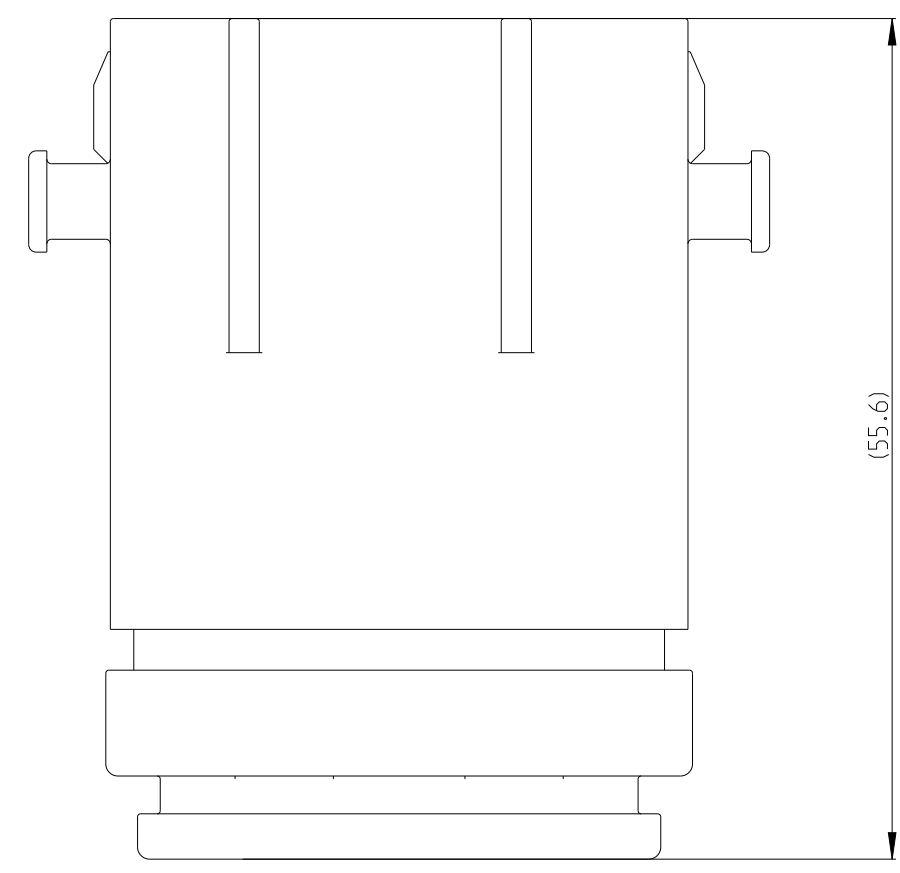

- THIS TAB HOUSING MATES WITH PLUG ASSEMBLY PN 2366494-X. (X=1, 2, 3, 4 FOR VARIOUS CODE).
- FOR FLANGE VERSION, NEED MATE WITH FIX RING PN 2366517-X. RECOMMENDED WALL INTERFACE SEE CUSTOMER DRAWING 2366517.
- MATERIAL SEE TABLE
- DATE CODE: IDENTIFIES THE YEAR, MONTH, DAY AND HOUR OF ASSEMBLY.
 YEAR: FIRST AND SECOND DIGITS(20=2020)
 MONTH: THIRD DIGIT, EXCLUDING 1, A=JAN, B=FEB, C=MARCH...(K=OCTOBER)
 DAY: FOURTH AND FIFTH DIGITS(14=14th DAY)
 HOUR: SIXTH AND SEVENTH DIGITS(11=11AM)
- IDENTIFICATION FOR CABLE PINOUT.
- TPA SEATED ON PRE-LOCK POSITION FOR DELIVERY.
- PULL TPA TO PRE-LOCK BEFORE TERMINAL INSERTION IN CASE OF TPA BEING HIT TO END-LOCK POSITION.
- REFER TO 114-151001 FOR DT SIZE 16 TERMINAL APPLICATION SPECIFICATION. REFER TO 114-151003 FOR DT SIZE 20 TERMINAL APPLICATION SPECIFICATION. APPLICABLE TERMINAL PART NUMBERS AND WIRE SIZE:

TERMINAL PN	WIRE SIZE (MM2)	INSULATION WIRE (MM2)	PIOUT NUMBER
16#	1.0-2.5	∅1.9-∅3.0	1,8,9,16,33,40,41,48
20#	0.5-1.5	∅1.4-∅2.4	OTHER PINS

- LASER PRODUCT PN. SUCH AS "--1" MEANS 2366509-1, "2--1" MEANS 2-2366509-1.
- REFER TO DRAWING 2373921 FOR APPLICABLE PART NO. OF SEALING PLUG.

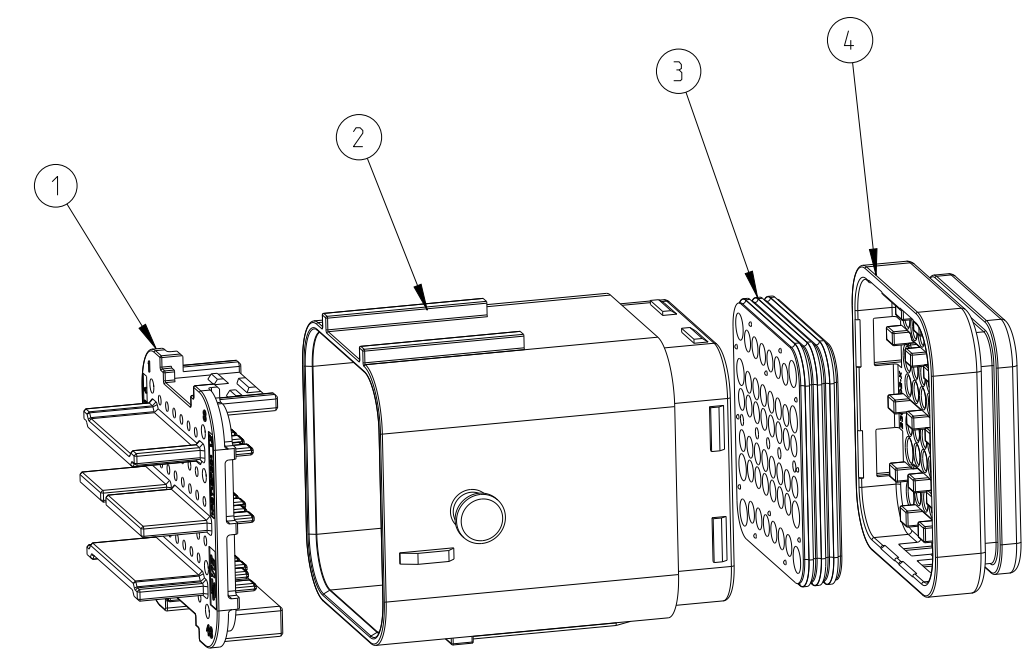
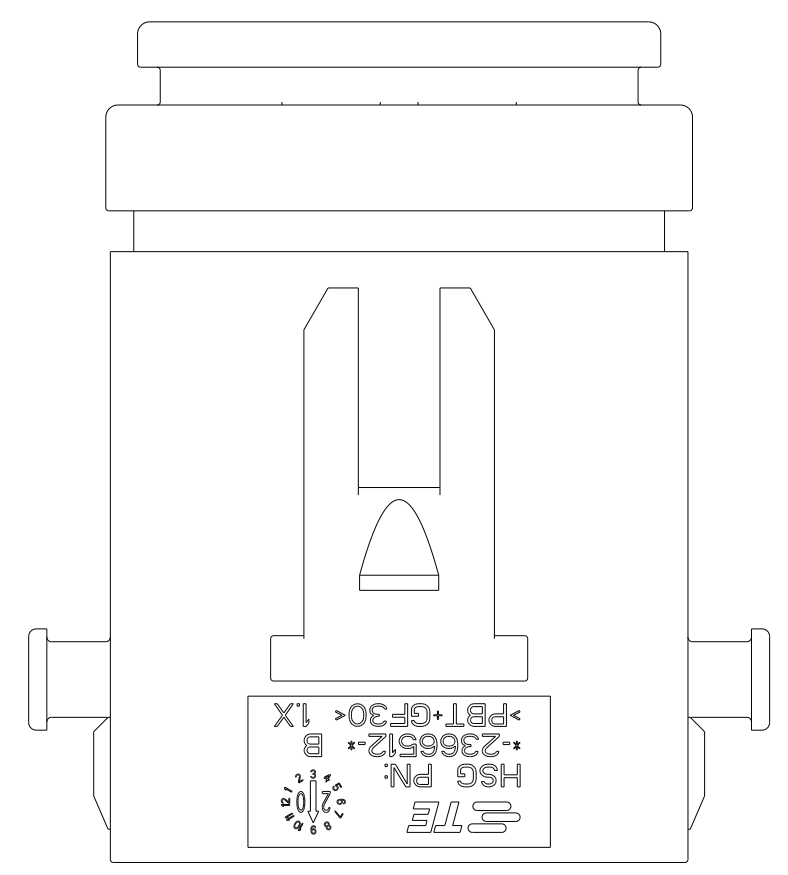

QTY.	REQUEST PER ASSY	COLOR	MATERIAL	DESCRIPTION	ITEM NO		
1	-	-	BLUE	PBT-GF30 REAR CAP	4		
-	1	-	GREEN				
-	-	1	GREY	PBT-GF30	2		
-	-	1	BLACK				
1	1	1	RUST RED			VMQ GROMMET	3
1	-	-	BLUE			HOUSING CODING D	
-	1	-	GREEN	HOUSING CODING C	2		
-	-	1	GREY	HOUSING CODING B			
-	-	1	BLACK	HOUSING CODING A	1		
1	1	1	YELLOW	PBT-GF30 TPA			
REVISION OF EACH ASSY PN							
TE ASSEMBLY PN							

THIS DRAWING IS A CONTROLLED DOCUMENT.

DWN: X.LI 19FEB2020
 CHK: W.WU 02MAR2020
 APVD: J.YIN 05MAR2020

STE TE Connectivity

NAME: NTS 48P TAB HSG ASSEMBLY

PRODUCT SPEC: 108-101662

APPLICATION SPEC: -

SIZE: A2 CAGE CODE: - DRAWING NO: C-2366509 RESTRICTED TO: -

WEIGHT: -

CUSTOMER DRAWING SCALE: 1:1 SHEET: 1 OF 2 REV: B1

TOLERANCES UNLESS OTHERWISE SPECIFIED:
 0 PLC ±
 1 PLC ±
 2 PLC ±
 3 PLC ±
 4 PLC ±
 ANGLES ±
 FINISH -

THIS DRAWING IS UNPUBLISHED. RELEASED FOR PUBLICATION 20
 © COPYRIGHT 20 BY - ALL RIGHTS RESERVED.

REVISIONS				
P	LTR	DESCRIPTION	DATE	APVD
-	-	SEE SHEET 1	-	-

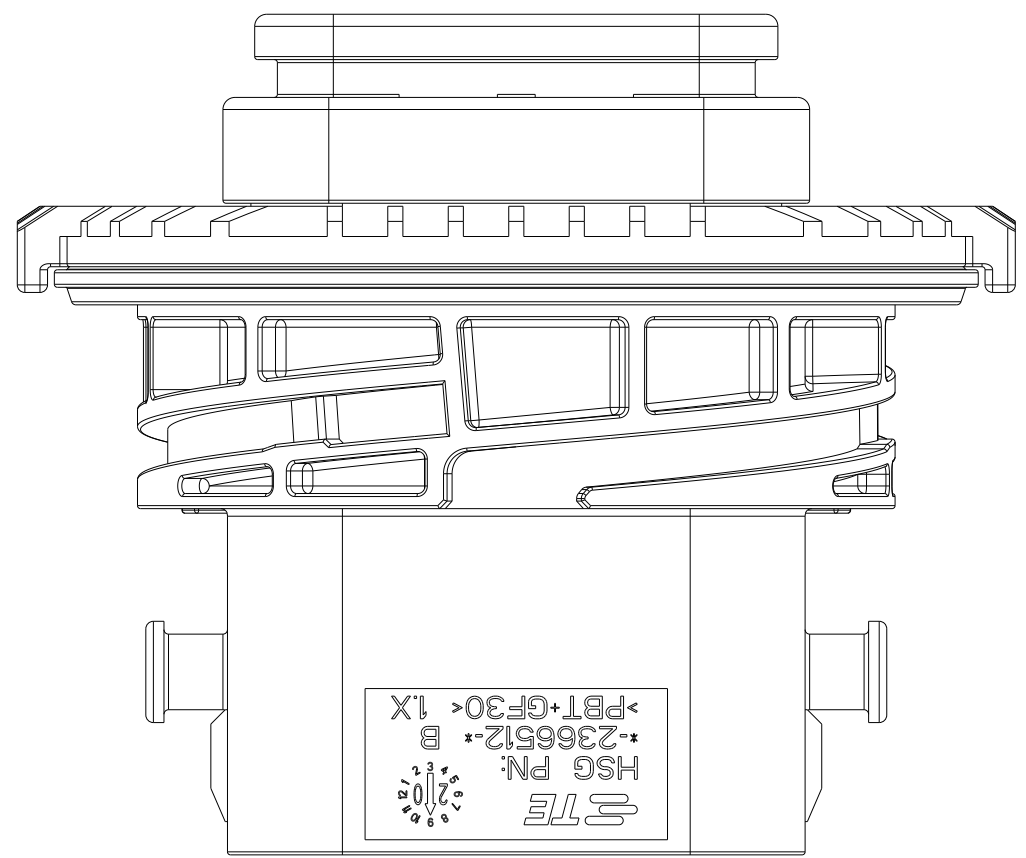
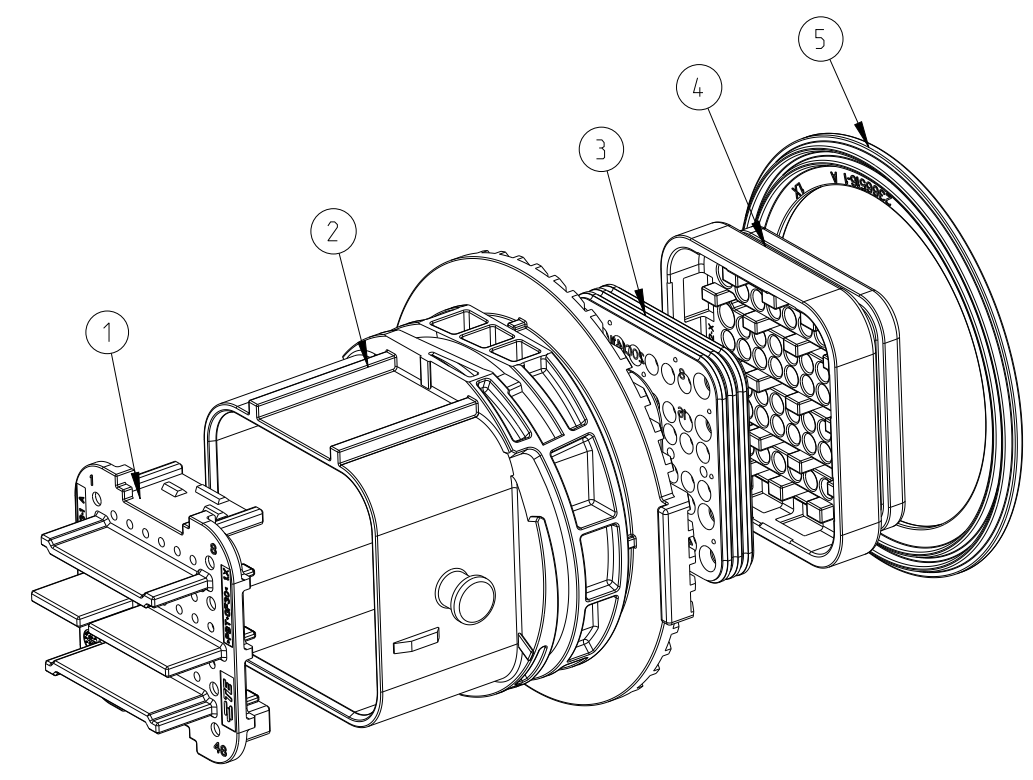
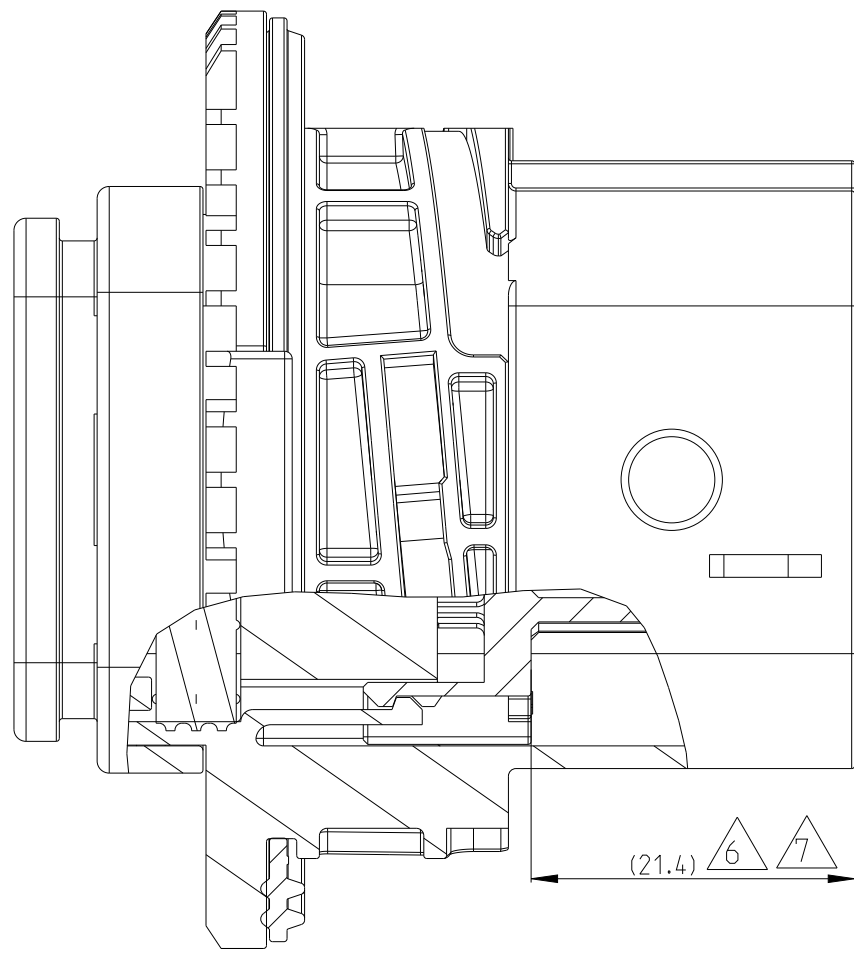
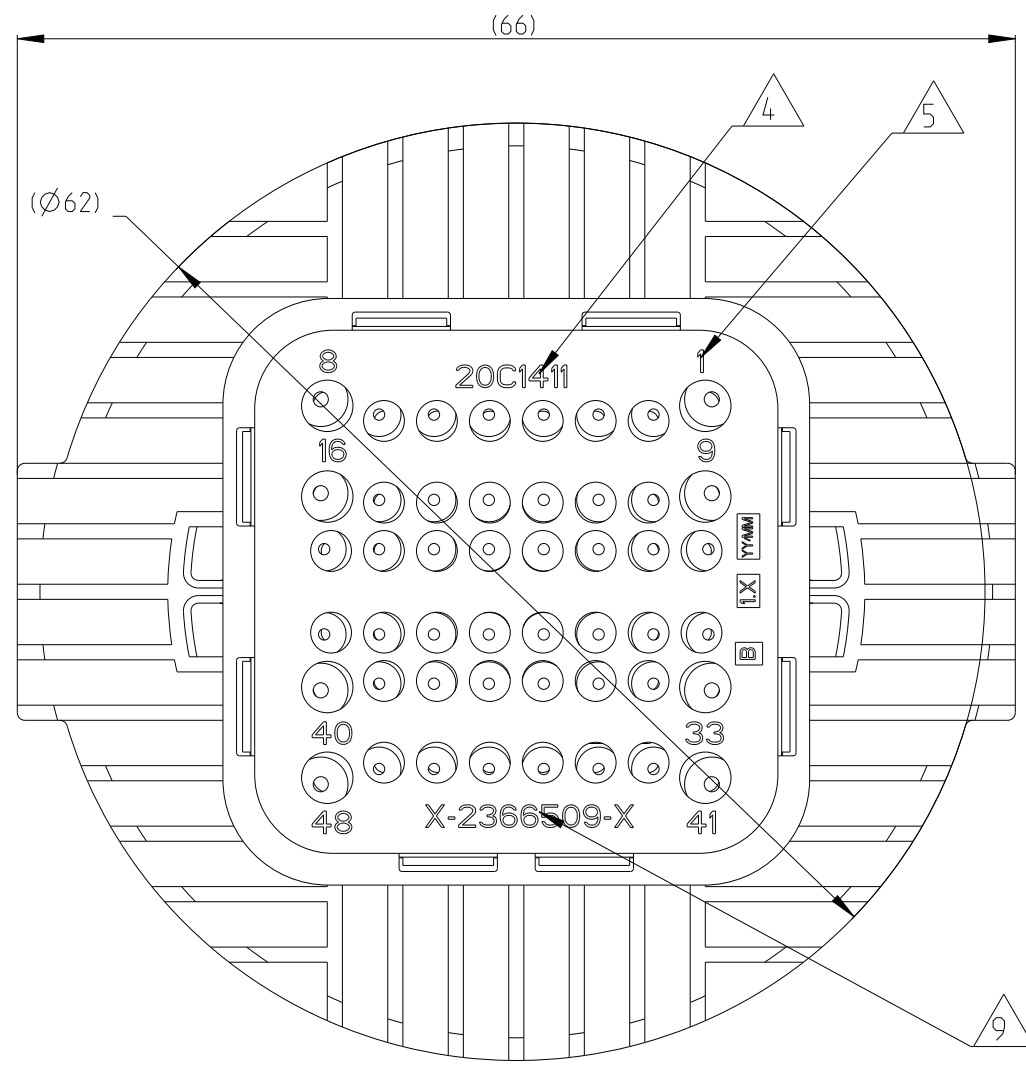
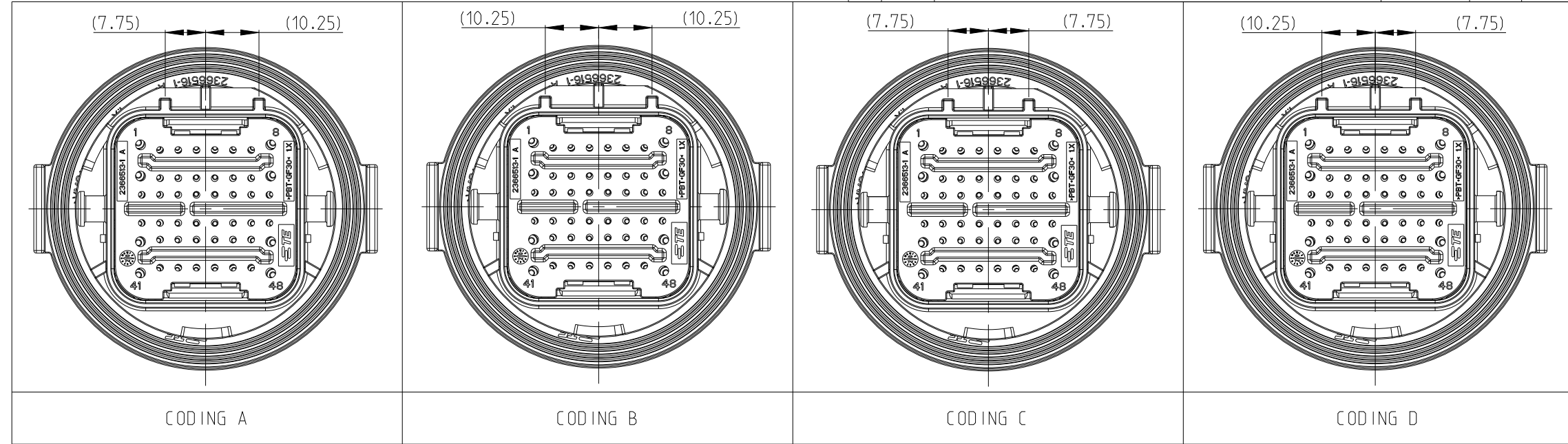
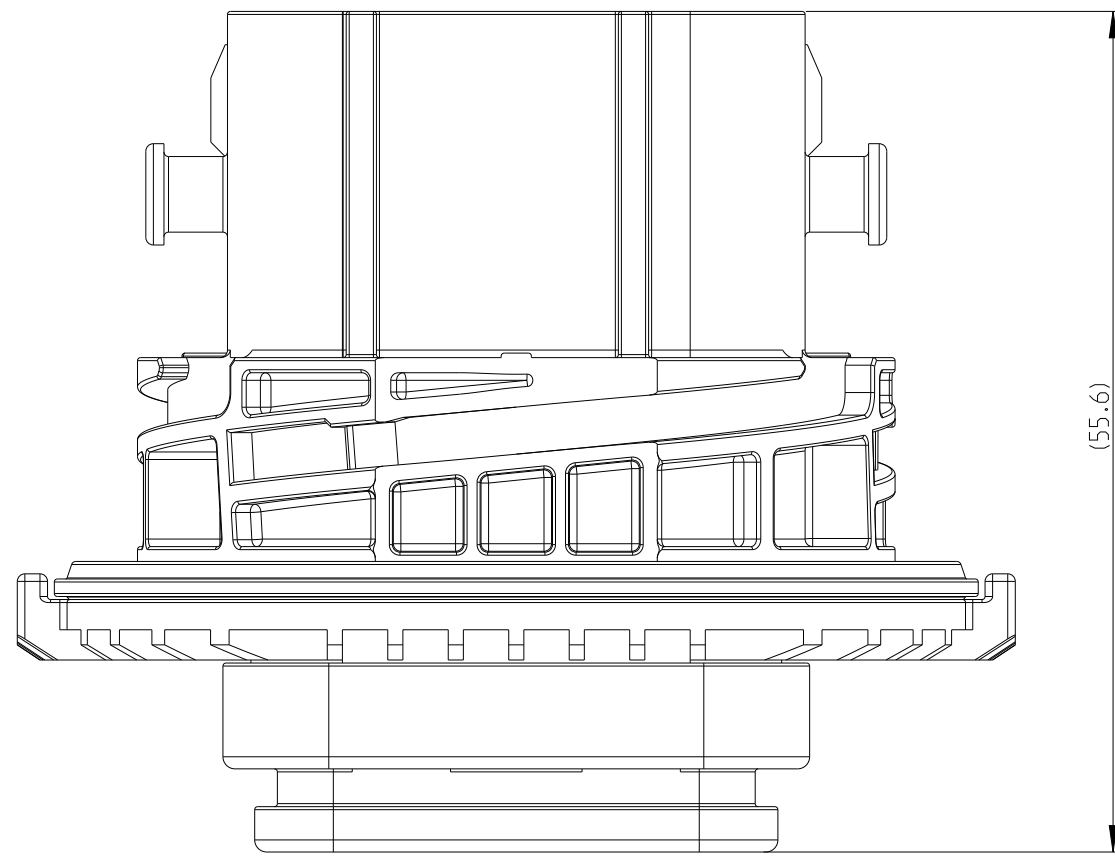

QTY.	REQUEST PER ASSY	COLOR	MATERIAL	DESCRIPTION	ITEM NO
1	1	1	1	RUST RED VMQ FACIAL SEAL	5
1	-	-	-	BLUE PBT-GF30 REAR CAP	4
-	1	-	-	GREEN	
-	-	1	-	GREY	
-	-	-	1	BLACK	
1	1	1	1	RUST RED VMQ GROMMET	3
1	-	-	-	BLUE	
-	1	-	-	GREEN PBT-GF30 HOUSING CODING D	2
-	-	1	-	GREY HOUSING CODING B	
-	-	-	1	BLACK HOUSING CODING A	
1	1	1	1	YELLOW PBT-GF30 TPA	1
REVISION OF EACH ASSY PN					
TE ASSEMBLY PN					

THIS DRAWING IS A CONTROLLED DOCUMENT.

DWN: X_LL 19FEB2020
 CHK: W_WU 02MAR2020
 APVD: J_YIN 05MAR2020

PRODUCT SPEC: 108-101662
 APPLICATION SPEC: -

WEIGHT: -

CUSTOMER DRAWING

SCALE: 1:1 SHEET: 2 OF 2 REV: B1

STE TE Connectivity

NAME: NTS 48P TAB HSG ASSEMBLY

SIZE: A2 CAGE CODE: - DRAWING NO: C-2366509 RESTRICTED TO: -