

PRODUCT NO.  
62684-\_\_21\_\_A\_LF  
PAPER REEL

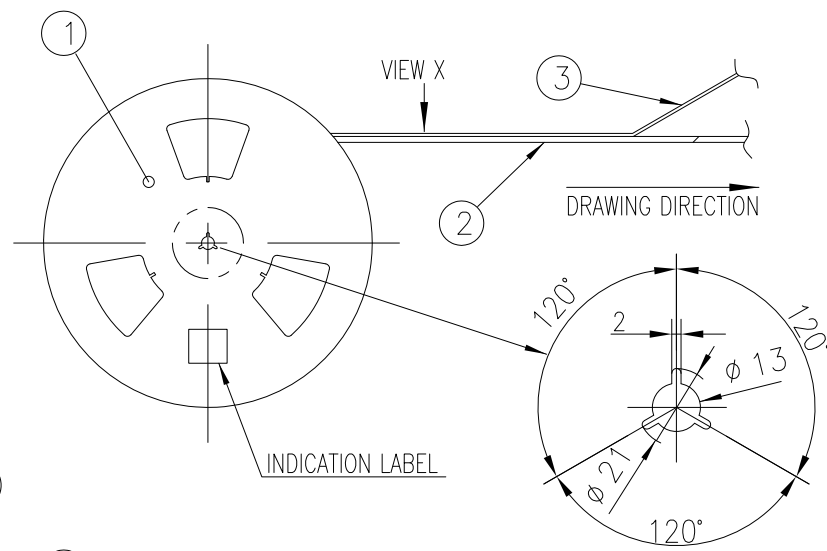

PLASTIC REEL

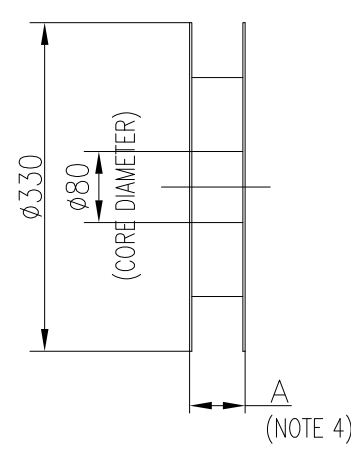
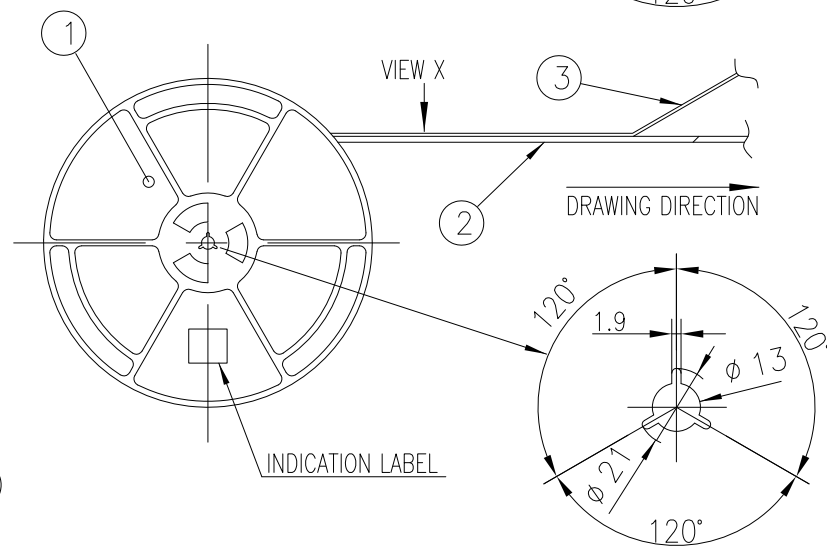
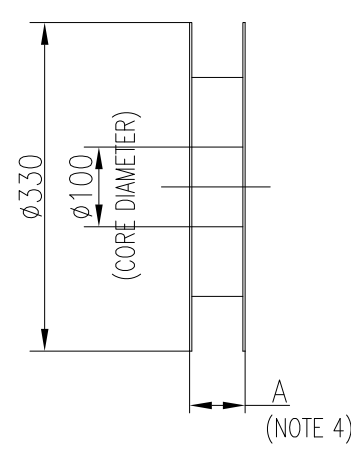

CAT. NO.	SURFACE TREATMENT	OTHER	REEL
62684-__21__0ALF	GOLD PLATING	_____	PAPER REEL
62684-__21__0AHLF		HALOGEN FREE	
62684-__21__1ALF		_____	PLASTIC REEL
62684-__21__1AHLF		HALOGEN FREE	

CAT. NO. & DIMENSIONS (PAPER REEL)

NO. OF CONTACTS (n)	CAT. NO.	DIMENSIONS			
		A ± 5	B ± 0.1	C ± 0.1	D ± 0.3
32	62684-322100ALF	48.4	20.2	40.4	44
34	62684-342100ALF	48.4	20.2	40.4	44
36	62684-362100ALF	48.4	20.2	40.4	44
40	62684-402100ALF	48.4	20.2	40.4	44
43	62684-432100ALF	48.4	20.2	40.4	44
45	62684-452100ALF	48.4	20.2	40.4	44
50	62684-502100ALF	48.4	20.2	40.4	44
55	62684-5521N0ALF	60.4	26.2	52.4	56
57	62684-5721N0ALF	60.4	26.2	52.4	56
32	62684-322100AHLF	48.4	20.2	40.4	44
40	62684-402100AHLF	48.4	20.2	40.4	44
45	62684-452100AHLF	48.4	20.2	40.4	44
50	62684-502100AHLF	48.4	20.2	40.4	44
50	62684-5021C0AHLF	48.4	20.2	40.4	44
45	62684-452160AHLF	48.4	20.2	40.4	44

CAT. NO. & DIMENSIONS (PLASTIC REEL)

NO. OF CONTACTS (n)	CAT. NO.	DIMENSIONS			
		A ± 5	B ± 0.1	C ± 0.1	D ± 0.3
36	62684-362101ALF	48.4	20.2	40.4	44
40	62684-402101ALF	48.4	20.2	40.4	44
45	62684-452101ALF	48.4	20.2	40.4	44
50	62684-502101ALF	48.4	20.2	40.4	44
40	62684-402121AHLF	48.4	20.2	40.4	44
45	62684-452121AHLF	48.4	20.2	40.4	44
50	62684-502121AHLF	48.4	20.2	40.4	44
55	62684-5521N1AHLF	60.4	26.2	52.4	56
57	62684-5721N1AHLF	60.4	26.2	52.4	56

PARTS LIST

PT NO	PARTS NAME	CAT. NO.	MATERIAL	Q'TY	NOTE
1	REEL	_____	CARDBOARD	1	COLOR : WHITE
			POLYSTYRENE	1	COLOR : WHITE or BLACK
2	PLASTIC (EMBOSS) TAPE	_____	PS or A-PET	---	COLOR : TRANSPARENCY
3	COVER	_____	POLYESTER/POLYETHYLENE	---	COLOR : TRANSPARENCY
4	CONNECTOR	62684-__21__A_LF	SEE SHEET 2	2000	

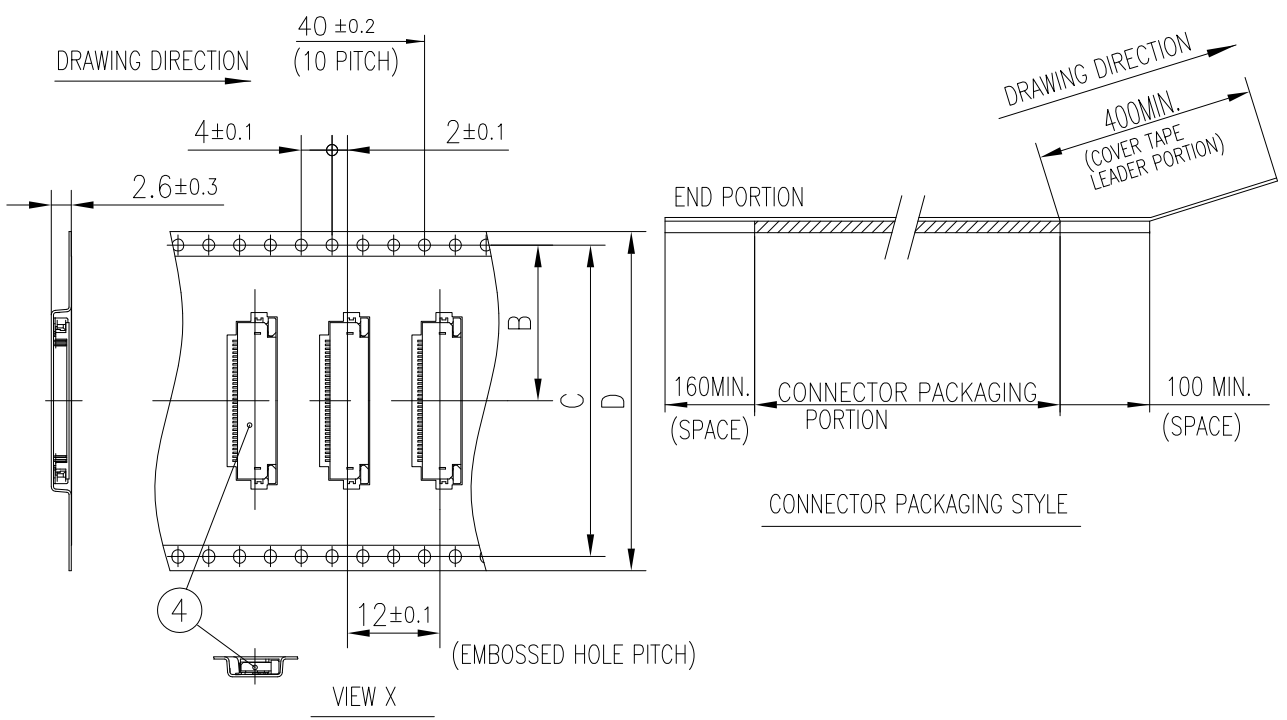

NOTE  
 1. THIS PRODUCT IS THE CONNECTOR USED FOR FPC AND COPES WITH AUTOMATIC MOUNTING(SMT).  
 2. THIS CATALOG NO. INDICATES PLASTIC TAPE PACKAGED CONNECTOR  
 3. SEE JIS C 0806 (PACKING OF ELECTRONIC COMPONENTS ON CONTINUOUS TAPES (SURFACE MOUNTING DEVICES)) FOR SHAPE AND DIMENSIONS OF PLASTIC (EMBOSS) TAPE AND REEL.  
 4. A DIMENSION IS PORTION OF THE CORE.

mat'l. code SEE_TABLE		surface ISO 1302 ✓		tolerance ISO 406 ISO 1101		projection MM		product family 58DF	
ltr	ecn no	dr	date	tolerances unless otherwise specified		MM		title PLASTIC TAPE PACKAGED 0.5mm CONTACT SPACING CONNECTOR	
A	J00527	T.H	2000-7-31	angles	linear	O.X/±5 O.XX/±5		scale N/A	
AH	ELX-J-19424	S.W	2014-11-13	0°±5'				dwg no	
AJ	ELX-J-21605	S.W	2015-8-6	dr	S.WATANABE	2021-11-25		sheet 1 of 5 size	
AK	ELX-J-33053	S.W	2019-3-28	engr	S.WATANABE	2021-11-25		62684 A3	
AL	ELX-J-36059	S.W	2020-2-17	chr	AN.MOHAMMAD-NABEEL	2021-11-25			
AM	ELX-J-43057	S.W	2021-11-25	appd	Y.KAMEDA	2021-11-25		type Product Customer Drawing	
sheet index	revision sheet	AM	AM	AM	AM	AM			
		1	2	3	4	5			

Amphenol FCI

© 2016 AFCI

PRODUCT NO.

62684-\_\_21\_A\_LF

PARTS LIST

PT NO.	PARTS NAME	MATERIAL		Q'TY	NOTE
		62684-__21_ALF	62684-__21_AHLF		
1	HOUSING	GLASS FILLED THERMOPLASTIC (UL94V-0)	GLASS FILLED THERMOPLASTIC (UL94V-0)(HALOGEN FREE)	1	COLOR : BEIGE
2	SLIDER	GLASS FILLED THERMOPLASTIC (UL94V-0)	GLASS FILLED THERMOPLASTIC (UL94V-0)(HALOGEN FREE)	1	COLOR : BLACK
3	CONTACT	PHOSPHOR BRONZE : Ni UNDERPLATED 1.27μmMIN. GOLD PLATING		n	Au PLATING THICKNESS : SEE RIGHT TABLE
4	MOUNTING PLATE	BRASS : Ni UNDERPLATED 1.27μmMIN. TIN PLATING 1μmMIN.		2	

PART NUMBER	SURFACE TREATMENT AND OTHER	CONTACT POINT
62684-__210ALF 62684-__21NALF	GOLD PLATING 0.05μmMIN.	SINGLE CONTACT POINT
62684-__210AHLF 62684-__212AHLF	GOLD PLATING 0.05μmMIN. / HALOGEN FREE	
62684-__21CAHLF	GOLD PLATING 0.76μmMIN. / HALOGEN FREE	DUAL CONTACT POINT
62684-__216AHLF	GOLD PLATING 0.76μmMIN. / HALOGEN FREE	

n : NO. OF CONTACTS

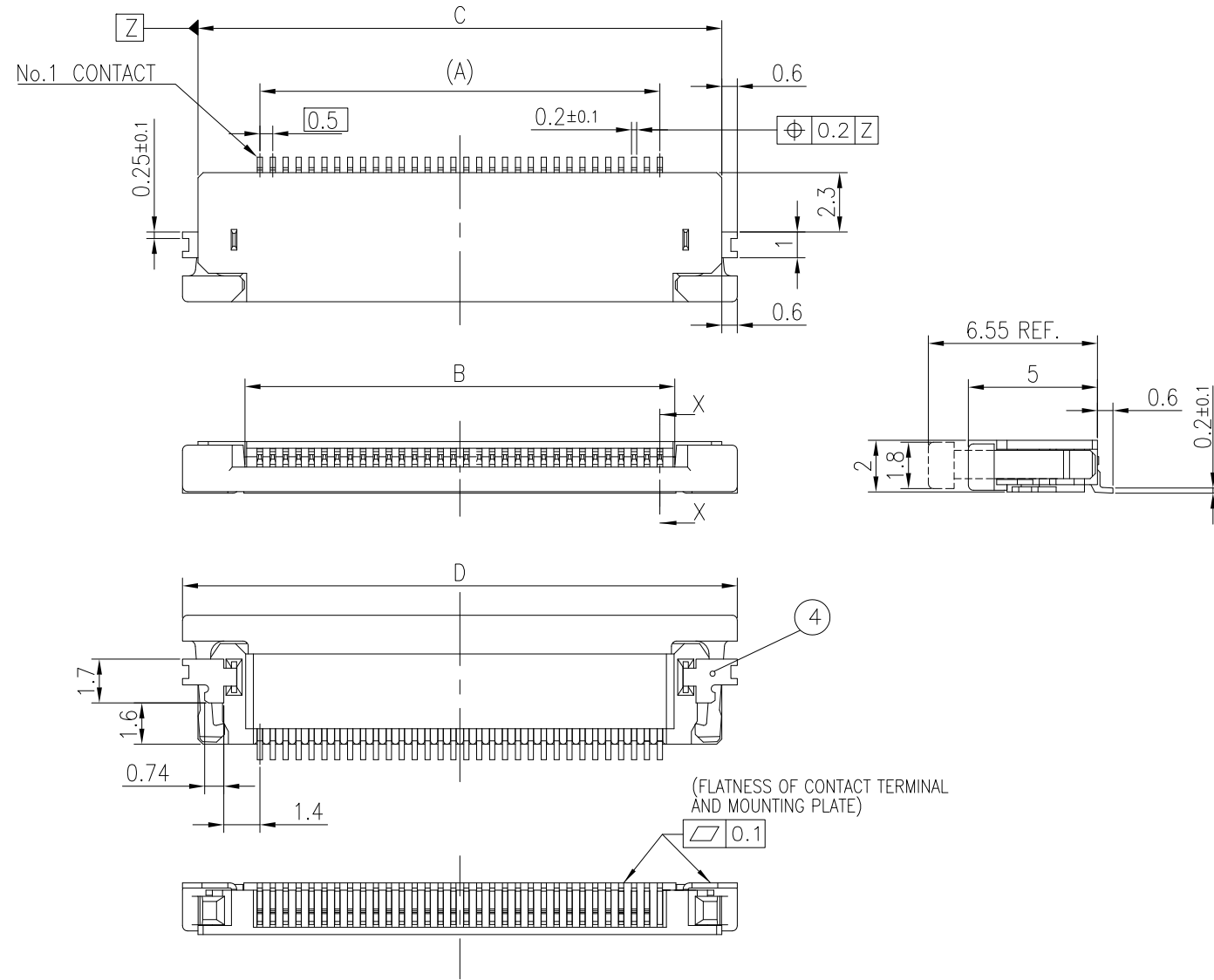

CAT. NO. & DIMENSIONS

NO. OF CONTACTS (n)	CAT. NO.	DIMENSIONS				HOUSING MATERIAL
		A	B	C	D	
32	62684-32210ALF	15.5	16.65	20.3	21.5	PA9T
34	62684-34210ALF	16.5	17.65	21.3	22.5	
36	62684-36210ALF	17.5	18.65	22.3	23.5	
40	62684-40210ALF	19.5	20.65	24.3	25.5	
43	62684-43210ALF	21	22.15	25.8	27	
45	62684-45210ALF	22	23.15	26.8	28	
50	62684-50210ALF	24.5	25.65	29.3	30.5	
55	62684-5521NALF	27	28.15	31.8	33	LCP
57	62684-5721NALF	28	29.15	32.8	34	
32	62684-32210AHLF	15.5	16.65	20.3	21.5	
40	62684-40210AHLF	19.5	20.65	24.3	25.5	
45	62684-45210AHLF	22	23.15	26.8	28	
50	62684-50210AHLF	24.5	25.65	29.3	30.5	
55	62684-5521NAHLF	27	28.15	31.8	33	
57	62684-5721NAHLF	28	29.15	32.8	34	
40	62684-40212AHLF	19.5	20.65	24.3	25.5	
45	62684-45212AHLF	22	23.15	26.8	28	
50	62684-50212AHLF	24.5	25.65	29.3	30.5	
50	62684-5021CAHLF	24.5	25.65	29.3	30.5	
45	62684-45216AHLF	22	23.15	26.8	28	

NOTE  
 1. THIS PRODUCT IS THE CONNECTOR USED FOR FPC AND COPES WITH AUTOMATIC MOUNTING (SMT).  
 2. SEE SHEET No.1 REGARDING PLASTIC TAPE PACKAGED PRODUCT.  
 3. SEE SHEET No.5 REGARDING RECOMMENDED PC BOARD LAYOUT AND CABLE.  
 4. THE HOUSING WILL WITHSTAND EXPOSURE TO 260°C PEAK TEMPERATURE FOR 10SECONDS IN A REFLOW SOLDERING OVEN.  
 5. THE PRODUCT THAT THE END HAS "LF" MEETS EUROPEAN DIRECTIVES AND OTHER COUNTRY REGULATIONS AS DESCRIBED IN GS-47-0004.

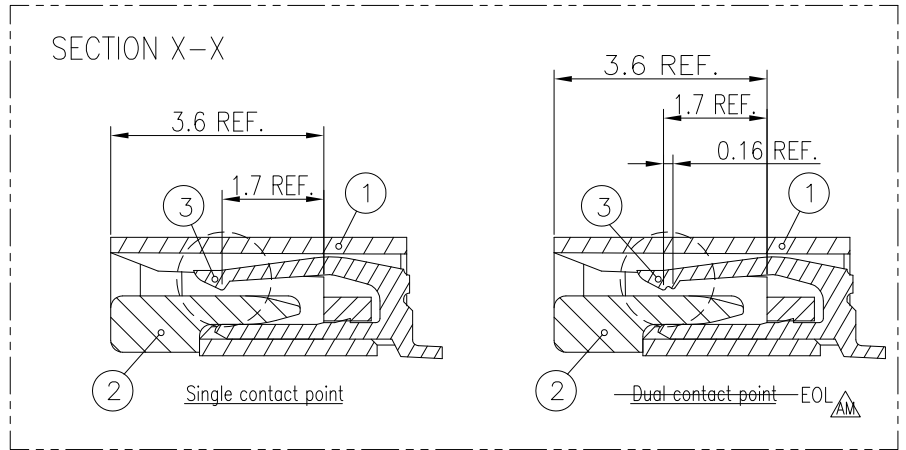

mat'l. code		surface		tolerance		projection		product family			
SEE_TABLE		ISO 1302 ✓		ISO 406 ISO 1101				58DF			
ltr	ecn no	dr	date	tolerances unless otherwise specified				title			
AM				angles linear		MM		0.5mm CONTACT SPACING CONNECTOR			
						scale N/A		dwg no			
				dr S.WATANABE 2021-11-25				sheet 2 of 5 size			
				enr S.WATANABE 2021-11-25				62684		A3	
				chr AN.MOHAMMAD-NABEEL 2021-11-25				type		Product Customer Drawing	
				appd Y.KAMEDA 2021-11-25							
sheet index	revision sheet										

Amphenol FCI

© 2016 AFCI

PRODUCT NO.  
62684-\_\_11\_\_A\_LF  
PAPER REEL

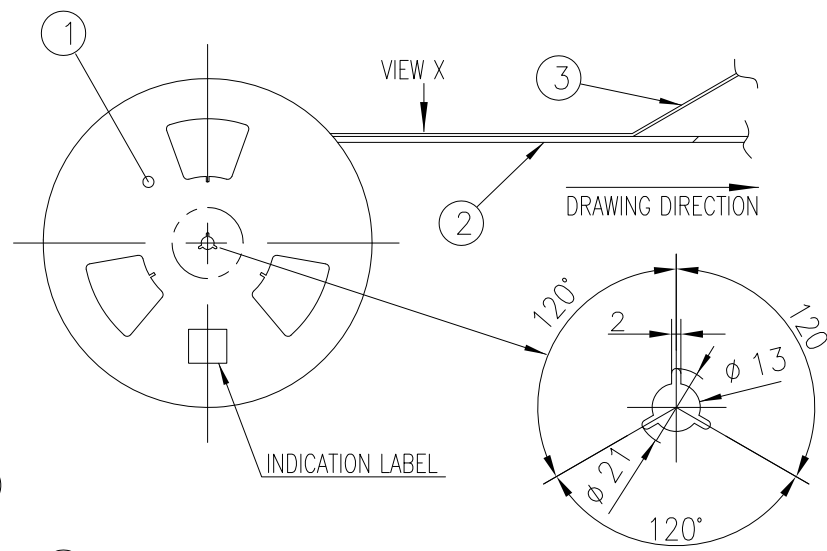
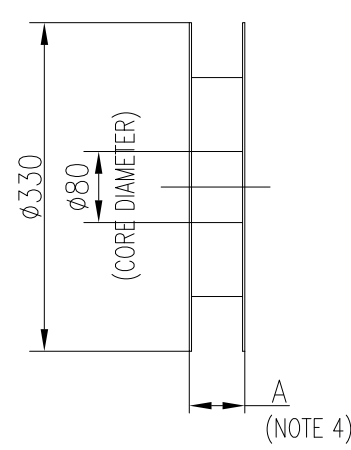

PLASTIC REEL  
Side view showing dimensions: outer diameter 330, core diameter 100, and width A (NOTE 4).

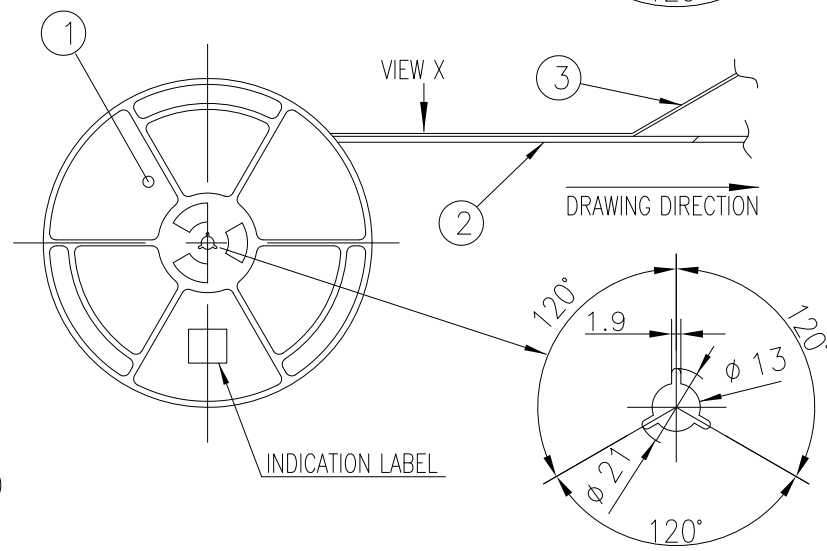

CAT. NO.	SURFACE TREATMENT	OTHER	REEL
62684-__11__0ALF	GOLD PLATING		PAPER REEL
62684-__11__0AHLF		HALOGEN FREE	
62684-__11__1ALF			PLASTIC REEL
62684-__11__1AHLF		HALOGEN FREE	

CAT. NO. & DIMENSIONS (PAPER REEL)

NO. OF CONTACTS (n)	CAT. NO.	DIMENSIONS			
		A ± 5	B ± 0.1	C ± 0.1	D ± 0.3
32	62684-321100ALF	48.4	20.2	40.4	44
38	62684-381100ALF	48.4	20.2	40.4	44
40	62684-401100ALF	48.4	20.2	40.4	44
45	62684-451100ALF	48.4	20.2	40.4	44
50	62684-501100ALF	48.4	20.2	40.4	44
55	62684-551100ALF	60.4	26.2	52.4	56
57	62684-571100ALF	60.4	26.2	52.4	56
60	62684-601100ALF	60.4	26.2	52.4	56
40	62684-401100AHLF	48.4	20.2	40.4	44
45	62684-451100AHLF	48.4	20.2	40.4	44
50	62684-501100AHLF	48.4	20.2	40.4	44
55	62684-551100AHLF	60.4	26.2	52.4	56
57	62684-571100AHLF	60.4	26.2	52.4	56
60	62684-601100AHLF	60.4	26.2	52.4	56
45	62684-451160AHLF	48.4	20.2	40.4	44
55	62684-551170AHLF	60.4	26.2	52.4	56

CAT. NO. & DIMENSIONS (PLASTIC REEL)

NO. OF CONTACTS (n)	CAT. NO.	DIMENSIONS			
		A ± 5	B ± 0.1	C ± 0.1	D ± 0.3
32	62684-321101ALF	48.4	20.2	40.4	44
40	62684-401101ALF	48.4	20.2	40.4	44
45	62684-451101ALF	48.4	20.2	40.4	44
50	62684-501101ALF	48.4	20.2	40.4	44
60	62684-6011N1ALF	60.4	26.2	52.4	56
55	62684-5511N1AHLF	60.4	26.2	52.4	56
57	62684-5711N1AHLF	60.4	26.2	52.4	56
60	62684-6011N1AHLF	60.4	26.2	52.4	56

PARTS LIST

PT NO	PARTS NAME	CAT. NO.	MATERIAL	Q'TY	NOTE
1	REEL		CARDBOARD	1	COLOR : WHITE
			POLYSTYRENE	1	COLOR : WHITE or BLACK
2	PLASTIC (EMBOSS) TAPE		PS or A-PET		COLOR : TRANSPARENCY
3	COVER		POLYESTER/POLYETHYLENE		COLOR : TRANSPARENCY
4	CONNECTOR	62684-__11__A_LF	SEE SHEET 4	2000	

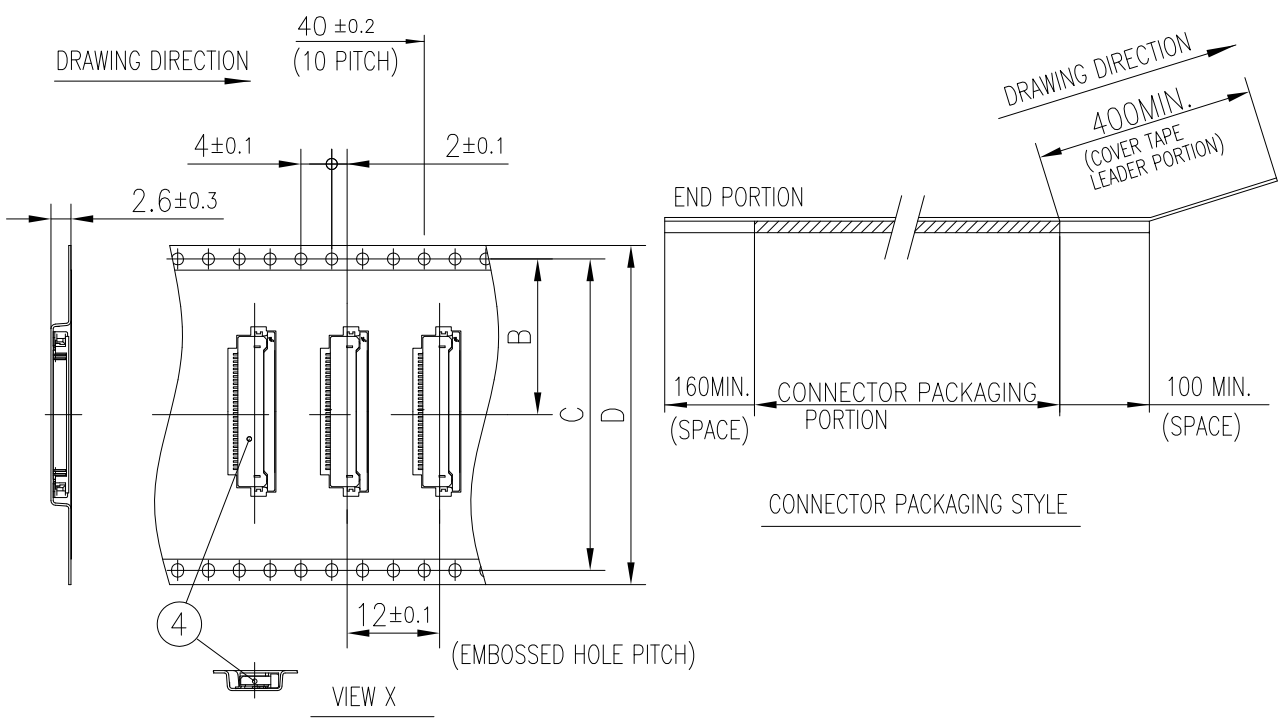

NOTE  
 1. THIS PRODUCT IS THE CONNECTOR USED FOR FPC AND COPES WITH AUTOMATIC MOUNTING(SMT).  
 2. THIS CATALOG NO. INDICATES PLASTIC TAPE PACKAGED CONNECTOR  
 3. SEE JIS C 0806 (PACKING OF ELECTRONIC COMPONENTS ON CONTINUOUS TAPES (SURFACE MOUNTING DEVICES)) FOR SHAPE AND DIMENSIONS OF PLASTIC (EMBOSS) TAPE AND REEL.  
 4. A DIMENSION IS PORTION OF THE CORE.

mat'l. code	surface	tolerance	projection	product family
SEE_TABLE	ISO 1302 ✓	ISO 406 ISO 1101		58CF
ltr	ecn no	dr	date	title
AM				PLASTIC TAPE PACKAGED 0.5mm CONTACT SPACING CONNECTOR
				angles
				linear
				0° ± 5°
				dr
				engr
				chr
				appd
				AMPHENOL FCI
				dwg no
				sheet 3 of 5
				size
				A3
				type
				Product Customer Drawing
sheet index	revision sheet			

Amphenol FCI

© 2016 AFCI

PRODUCT NO.

62684-\_\_11\_A\_LF

PARTS LIST

PT NO.	PARTS NAME	MATERIAL		Q'TY	NOTE
		62684-__11_ALF	62684-__11_AHLF		
1	HOUSING	GLASS FILLED THERMOPLASTIC (UL94V-0)	GLASS FILLED THERMOPLASTIC (UL94V-0)(HALOGEN FREE)	1	COLOR : BEIGE
2	SLIDER	GLASS FILLED THERMOPLASTIC (UL94V-0)	GLASS FILLED THERMOPLASTIC (UL94V-0)(HALOGEN FREE)	1	COLOR : BLACK
3	CONTACT	PHOSPHOR BRONZE : Ni UNDERPLATED 1.27μmMIN. GOLD PLATING 0.05μmMIN.		n	
4	MOUNTING PLATE	BRASS : Ni UNDERPLATED 1.27μmMIN. TIN PLATING 1μmMIN.		2	

PART NUMBER	SURFACE TREATMENT AND OTHER	CONTACT POINT
62684-__110ALF 62684-__111NALF	GOLD PLATING	SINGLE CONTACT POINT
62684-__110AHLF 62684-__111NAHLF	GOLD PLATING / HALOGEN FREE	
62684-__116AHLF 62684-__117AHLF	GOLD PLATING / HALOGEN FREE	DUAL CONTACT POINT

n : NO. OF CONTACTS

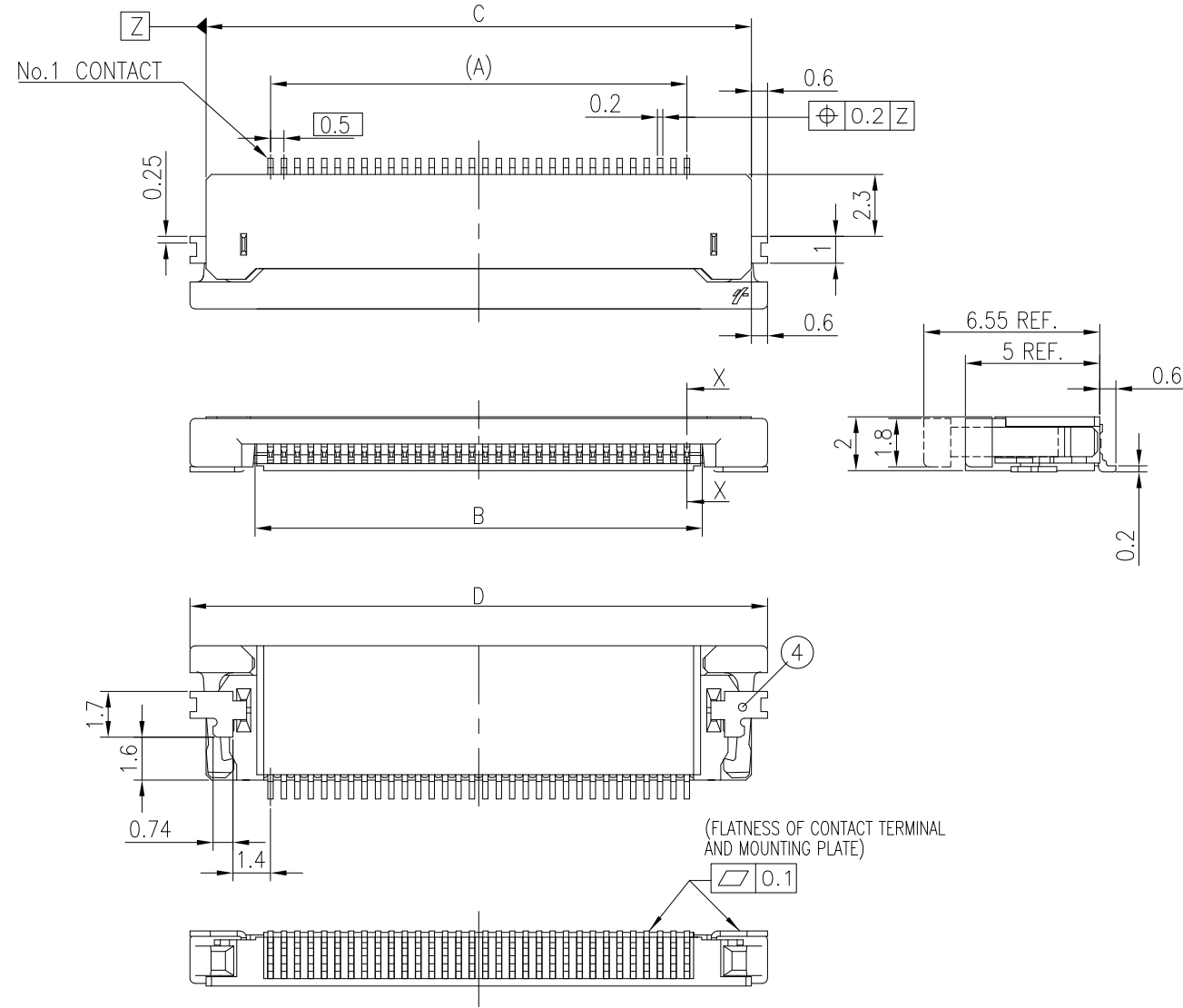

CAT. NO. & DIMENSIONS

NO. OF CONTACTS (n)	CAT. NO.	DIMENSIONS				HOUSING MATERIAL
		A	B	C	D	
32	62684-32110ALF	15.5	16.65	20.3	21.5	PA9T
38	62684-38110ALF	18.5	19.65	23.3	24.5	
40	62684-40110ALF	19.5	20.65	24.3	25.5	
45	62684-45110ALF	22	23.15	26.8	28	
50	62684-50110ALF	24.5	25.65	29.3	30.5	
55	62684-5511NALF	27	28.15	31.8	33	
57	62684-5711NALF	28	29.15	32.8	34	
60	62684-6011NALF	29.5	30.65	34.3	35.5	
40	62684-40110AHLF	19.5	20.65	24.3	25.5	LCP
45	62684-45110AHLF	22	23.15	26.8	28	
50	62684-50110AHLF	24.5	25.65	29.3	30.5	
55	62684-5511NAHLF	27	28.15	31.8	33	
57	62684-5711NAHLF	28	29.15	32.8	34	
60	62684-6011NAHLF	29.5	30.65	34.3	35.5	
45	62684-45116AHLF	22	23.15	26.8	28	
55	62684-55117AHLF	27	28.15	31.8	33	

SECTION X-X

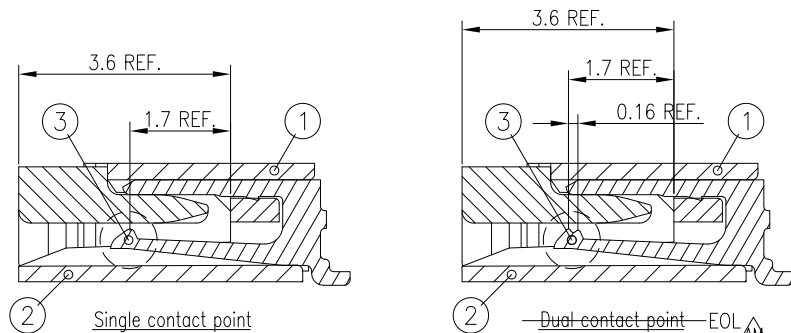

NOTE

1. THIS PRODUCT IS THE CONNECTOR USED FOR FPC AND COPES WITH AUTOMATIC MOUNTING (SMT).
2. SEE SHEET No.3 REGARDING PLASTIC TAPE PACKAGED PRODUCT.
3. SEE SHEET No.5 REGARDING RECOMMENDED PC BOARD LAYOUT AND CABLE.
4. THE HOUSING WILL WITHSTAND EXPOSURE TO 260°C PEAK TEMPERATURE FOR 10SECONDS IN A REFLOW SOLDERING OVEN.
5. THE PRODUCT THAT THE END HAS "LF" MEETS EUROPEAN DIRECTIVES AND OTHER COUNTRY REGULATIONS AS DESCRIBED IN GS-47-0004.

mat'l. code		surface		tolerance		projection		product family		
SEE_TABLE		ISO 1302 ✓		ISO 406 ISO 1101				58CF		
ltr	ecn no	dr	date	tolerances unless otherwise specified				title		
AM				angles linear		MM		0.5mm CONTACT SPACING CONNECTOR		
						scale N/A		dwg no		
				dr	S.WATANABE	2021-11-25			sheet 4 of 5	
				enr	S.WATANABE	2021-11-25			62684	A3
				chr	AN.MOHAMMAD-NABEEL	2021-11-25				
				appd	Y.KAMEDA	2021-11-25	type		Product Customer Drawing	
sheet index	revision sheet									

RECOMMENDED PC BOARD LAYOUT  
(COMPONENT SIDE)

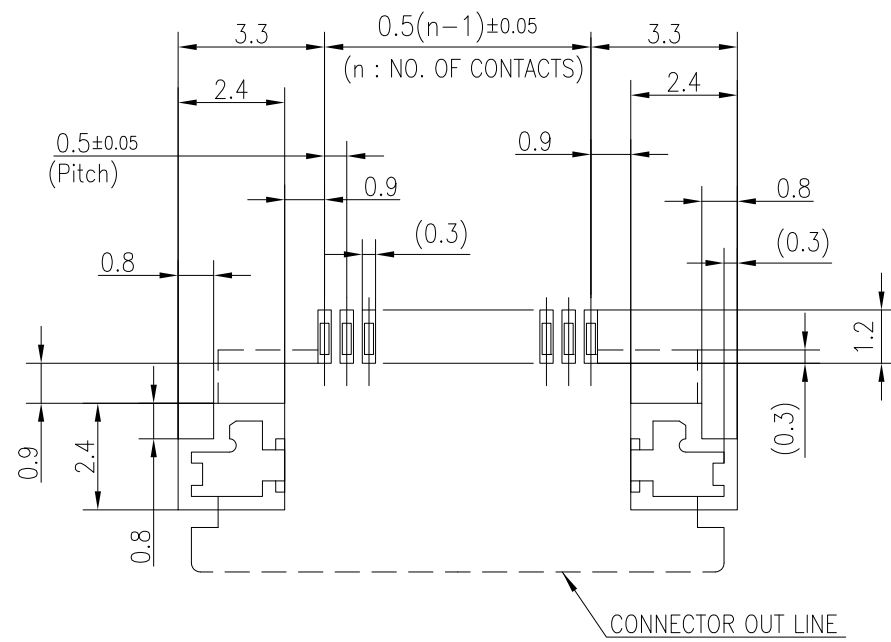

RECOMMENDED CABLE (FPC)

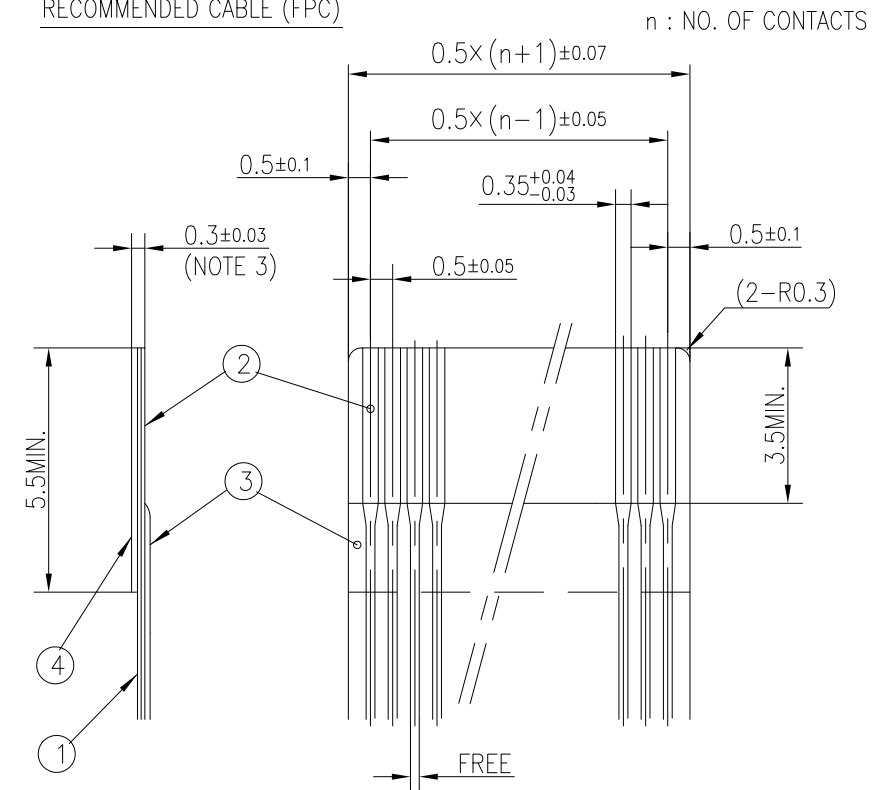

PT NO.	PARTS NAME	MATERIAL	THICKNESS ( $\mu m$ )
1	BASE FILM	POLYIMIDE OR POLYESTER OR EQUAL	25
2	CONDUCTOR	COPPER FOIL(Gold plating)	35 OR 50
3	OVERLAY	POLYIMIDE OR POLYESTER OR EQUAL	—
4	SUPPORTING TAPE	POLYIMIDE OR POLYESTER OR EQUAL	—

NOTE

- 1.NOBURR AT EACH PORTION
- 2.NO PEELING IN COMMON USE.
- 3.TOTAL THICKNESS LIMIT OF EACH MATERIAL (INCLUDING ADHESIVE AGENT) IS SPECIFIED.

mat'l. code SEE_TABLE		surface ISO 1302 <input checked="" type="checkbox"/>	tolerance ISO 406 ISO 1101	projection 	product family 58CF/DF
ltr AM	ecn no	dr	date	tolerances unless otherwise specified angles linear	title RECOMMENDED CABLE
				0.X/±0.05 0.XX/±0.05	MM
					scale N/A
		dr	S.WATANABE	2021-11-25	dwg no
		enr	S.WATANABE	2021-11-25	sheet 5 of 5
		chr	AN.MOHAMMAD-NABEEL	2021-11-25	62684
		appd	Y.KAMEDA	2021-11-25	size A3
sheet index	revision sheet				type Product Customer Drawing