

Metall-Platte mit Löcher
metal-plate with holes

Kunststoff-Einsatz
plastic-core

Metall-Platte ohne Löcher
metal-plate without holes

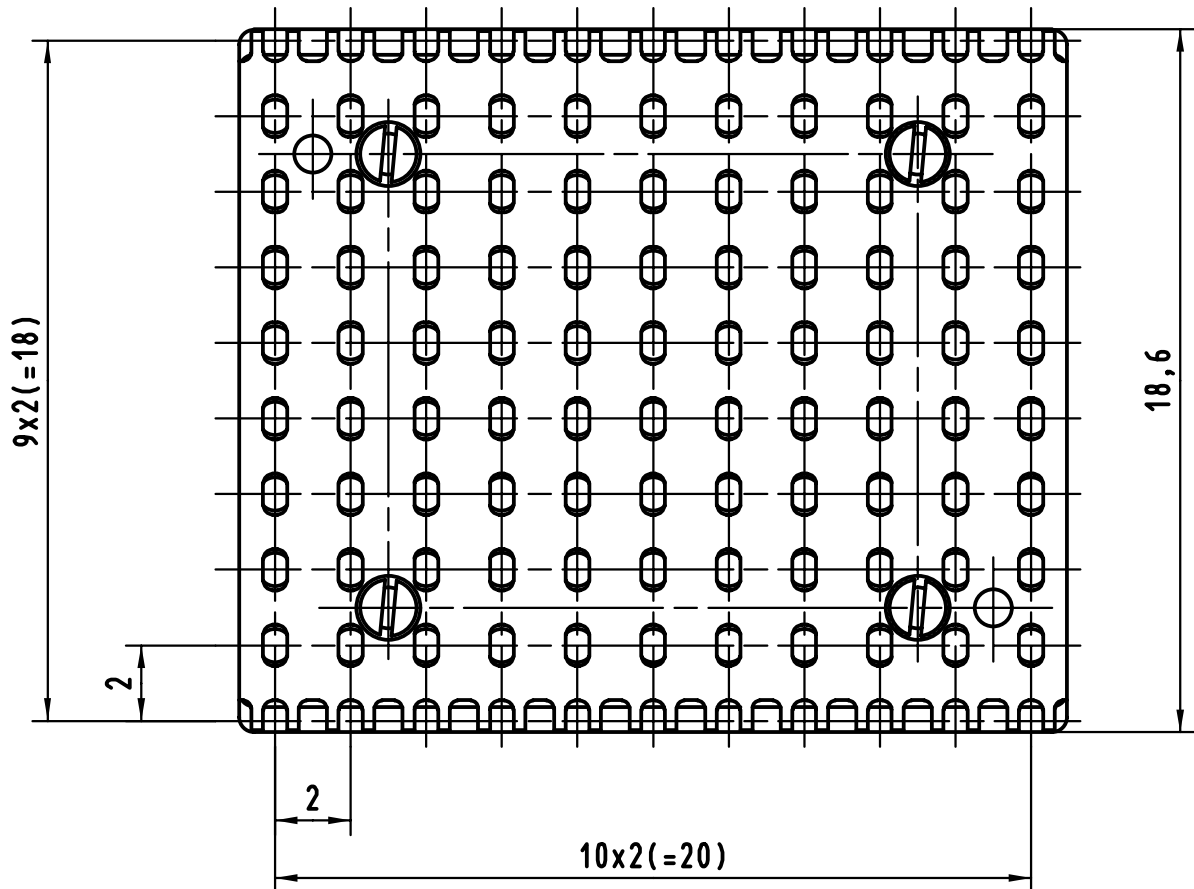
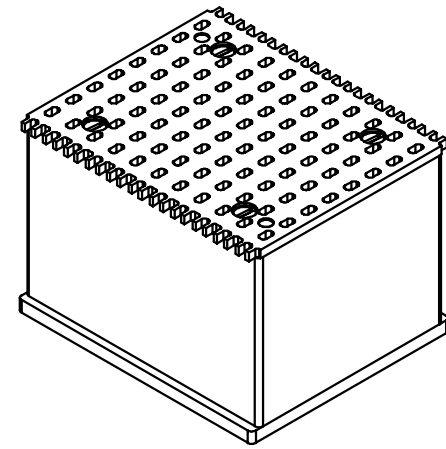

Alle Rechte vorbehalten/ All rights reserved

		Techn. Character.			Nicht tolerierte Maße/ Free size tolerances	
		Dat. Name		Maßstab/Scale		
		Detail. 11.09.98 Hage		5:1		
		Insp. 11.09.98 Wae				
		Stand.				
24585		HARTING KGaA			TB 17 99 000 0006	
1Druckblech 20.07.99 Hage		D-32339 ESPELKAMP				
Mod. Dat. Name					Blatt/ page	