

150kHz 3A BUCK DC-DC CONVERTER**AP3003****General Description**

The AP3003 series of regulators are fixed frequency PWM buck (step-down) DC/DC converter, capable of driving a 3A load with excellent line and load regulation. These regulators include internal frequency compensation and a fixed frequency oscillator so that they are easy to use. A system adopting AP3003 requires a minimum number of external components to work.

A standard series of inductors, optimized for use with the AP3003 series, are available from several manufacturers. This feature greatly simplifies the design of switch-mode power supplies.

These ICs are available in TO-220-5 and TO-263-5 packages.

Features

- 3.3V, 5V, 12V Fixed ($\pm 4\%$ Tolerance) and Adjustable ($\pm 3\%$ Tolerance) Output Versions
- Guaranteed 3A Output Load Current
- 150kHz Fixed Frequency Internal Oscillator
- Input Voltage Range up to 32V
- Requires only 4 external components
- High Efficiency up to 90%
- Excellent Line and Load Regulation
- TTL Shutdown Capability
- Low Power Standby Mode, I_Q Typically 80 μ A
- Built-in Current Limit Protection and Thermal Shutdown Circuit

Applications

- LCD Monitor and LCD TV
- On-Card DC-DC Converter
- DVD Recorder
- PDP

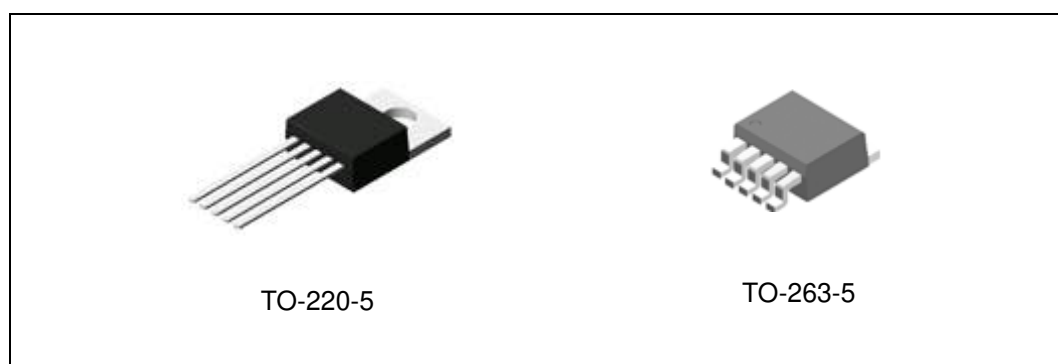

Figure 1. Package Types of AP3003

150kHz 3A BUCK DC-DC CONVERTER
AP3003
Pin Configuration

Figure 2. Pin Configuration of AP3003 (Top View)

Pin Description

Pin Number	Pin Name	Function
1	V_{IN}	Unregulated input voltage
2	OUTPUT	Switch driver output
3	GND	Ground
4	FEEDBACK	Feedback Pin. For fixed version, connect it to system output. For adjustable version, connect it with an external resistor and capacitor feedback network to program the system output voltage
5	$\overline{ON/OFF}$	The TTL logic compatible input to control the regulator on or off

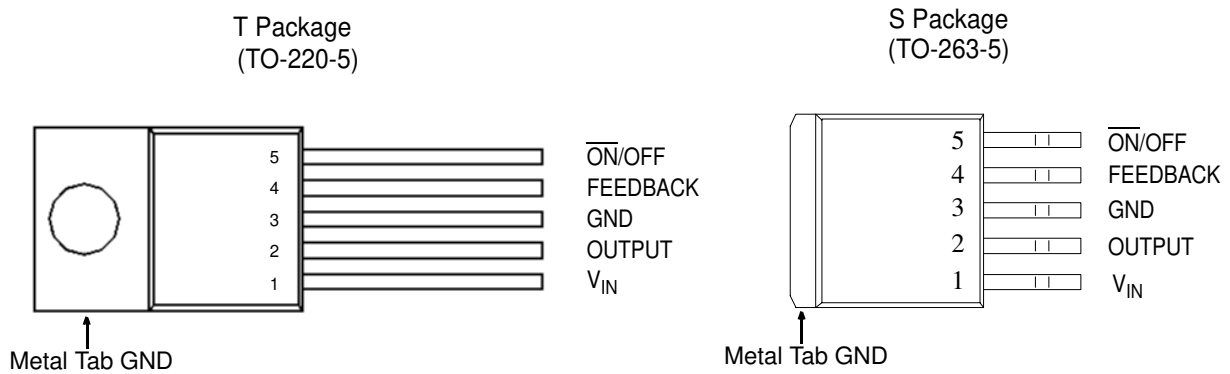

150kHz 3A BUCK DC-DC CONVERTER

AP3003

Functional Block Diagram

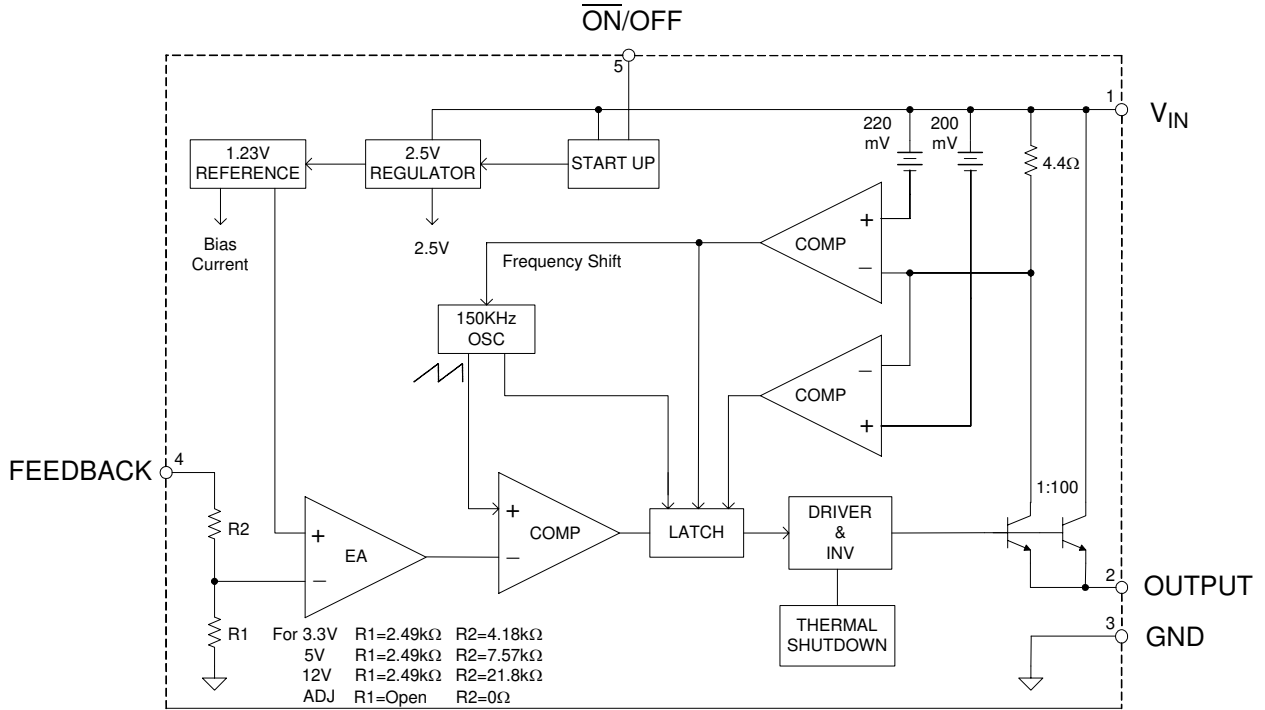

Figure 3. Functional Block Diagram of AP3003



150kHz 3A BUCK DC-DC CONVERTER

AP3003

Ordering Information

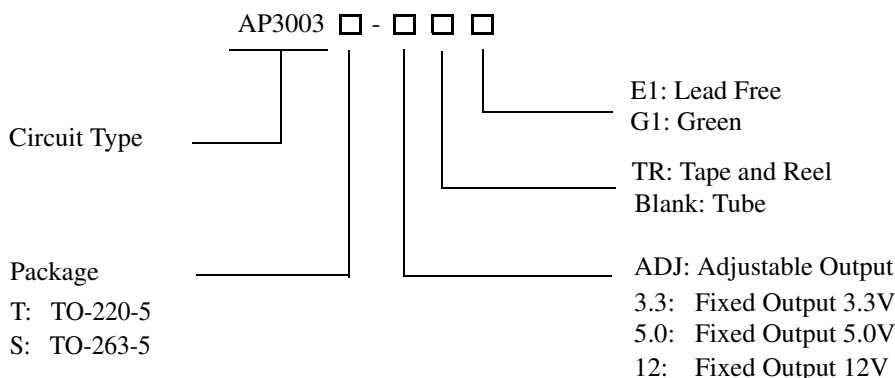

Package	Temperature Range	Part Number		Marking ID		Packing Type
		Lead Free	Green	Lead Free	Green	
TO-220-5	-40 to 85°C	AP3003T-ADJE1	AP3003T-ADJG1	AP3003T-ADJE1	AP3003T-ADJG1	Tube
		AP3003T-3.3E1	AP3003T-3.3G1	AP3003T-3.3E1	AP3003T-3.3G1	Tube
		AP3003T-5.0E1	AP3003T-5.0G1	AP3003T-5.0E1	AP3003T-5.0G1	Tube
		AP3003T-12E1	AP3003T-12G1	AP3003T-12E1	AP3003T-12G1	Tube
TO-263-5	-40 to 85°C	AP3003S-ADJE1	AP3003S-ADJG1	AP3003S-ADJE1	AP3003S-ADJG1	Tube
		AP3003S-ADJTRE1	AP3003S-ADJTRG1	AP3003S-ADJE1	AP3003S-ADJG1	Tape & Reel
		AP3003S-3.3E1	AP3003S-3.3G1	AP3003S-3.3E1	AP3003S-3.3G1	Tube
		AP3003S-3.3TRE1	AP3003S-3.3TRG1	AP3003S-3.3E1	AP3003S-3.3G1	Tape & Reel
		AP3003S-5.0E1	AP3003S-5.0G1	AP3003S-5.0E1	AP3003S-5.0G1	Tube
		AP3003S-5.0TRE1	AP3003S-5.0TRG1	AP3003S-5.0E1	AP3003S-5.0G1	Tape & Reel
		AP3003S-12E1	AP3003S-12G1	AP3003S-12E1	AP3003S-12G1	Tube
		AP3003S-12TRE1	AP3003S-12TRG1	AP3003S-12E1	AP3003S-12G1	Tape & Reel

BCD Semiconductor's Pb-free products, as designated with "E1" suffix in the part number, are RoHS compliant. Products with "G1" suffix are available in green packages.

**150kHz 3A BUCK DC-DC CONVERTER****AP3003****Absolute Maximum Ratings (Note 1)**

Parameter	Symbol	Value	Unit	
Input Voltage	V_{IN}	40	V	
\overline{ON} /OFF Pin Voltage	$V_{\overline{ON}/OFF}$	40	V	
Feedback Pin Voltage	V_{FB}	40	V	
Operating Junction Temperature	T_J	150	°C	
Thermal Resistance (Junction to Ambient, No Heatsink)	TO-220-5	$R_{\theta JA}$	60	°C/W
	TO-263-5			
Lead Temperature (Soldering, 10sec)	T_{LEAD}	260	°C	
Storage Temperature Range	T_{STG}	-65 to 150	°C	

Note 1: Stresses greater than those listed under "Absolute Maximum Ratings" may cause permanent damage to the device. These are stress ratings only, and functional operation of the device at these or any other conditions beyond those indicated under "Recommended Operating Conditions" is not implied. Exposure to "Absolute Maximum Ratings" for extended periods may affect device reliability.

Recommended Operating Conditions

Parameter	Symbol	Value	Unit
Maximum Input Voltage (Note 2)	V_{IN}	3.3V	V
		5.0V	
		12V	
		ADJ ($V_{OUT}=3.2V$)	
		ADJ ($V_{OUT}=2.5V$)	
Operating Junction Temperature	T_J	-40 to 125	°C

Note 2: For ADJ version, the recommended supply voltage depends on the needed output voltage.

**150kHz 3A BUCK DC-DC CONVERTER****AP3003****Electrical Characteristics****For 3.3V Output Voltage Version**

Unless otherwise specified, $T_J=25^{\circ}\text{C}$. The specifications with **boldface type** apply over Full Operating Junction Temperature Range.

Parameter	Symbol	Conditions	Min	Typ	Max	Unit
Output Voltage	V_{OUT}	$5.5\text{V} \leq V_{\text{IN}} \leq 32\text{V}$, $0.2\text{A} \leq I_{\text{LOAD}} \leq 3\text{A}$	3.168 3.135	3.3	3.432 3.465	V
Efficiency	η	$V_{\text{IN}}=12\text{V}$, $I_{\text{LOAD}}=3\text{A}$		75		%

For 5V Output Voltage Version

Unless otherwise specified, $T_J=25^{\circ}\text{C}$. The specifications with **boldface type** apply over Full Operating Junction Temperature Range.

Parameter	Symbol	Conditions	Min	Typ	Max	Unit
Output Voltage	V_{OUT}	$7\text{V} \leq V_{\text{IN}} \leq 32\text{V}$, $0.2\text{A} \leq I_{\text{LOAD}} \leq 3\text{A}$	4.800 4.750	5	5.200 5.250	V
Efficiency	η	$V_{\text{IN}}=12\text{V}$, $I_{\text{LOAD}}=3\text{A}$		80		%

For 12V Output Voltage Version

Unless otherwise specified, $T_J=25^{\circ}\text{C}$. The specifications with **boldface type** apply over Full Operating Junction Temperature Range.

Parameter	Symbol	Conditions	Min	Typ	Max	Unit
Output Voltage	V_{OUT}	$15\text{V} \leq V_{\text{IN}} \leq 32\text{V}$, $0.2\text{A} \leq I_{\text{LOAD}} \leq 3\text{A}$	11.52 11.40	12.0	12.48 12.60	V
Efficiency	η	$V_{\text{IN}}=24\text{V}$, $I_{\text{LOAD}}=3\text{A}$		88		%

For ADJ Output Voltage Version

Unless otherwise specified, $T_J=25^{\circ}\text{C}$. The specifications with **boldface type** apply over Full Operating Junction Temperature Range.

Parameter	Symbol	Conditions	Min	Typ	Max	Unit
Feedback Voltage	V_{FB}	$4.5\text{V} \leq V_{\text{IN}} \leq 25\text{V}$, $0.2\text{A} \leq I_{\text{LOAD}} \leq 3\text{A}$, V_{OUT} programmed for 2.5V	1.193 1.18	1.23	1.267 1.28	V
Efficiency	η	$V_{\text{IN}}=12\text{V}$, $I_{\text{LOAD}}=3\text{A}$, $V_{\text{OUT}}=2.5\text{V}$		73		%

**150kHz 3A BUCK DC-DC CONVERTER****AP3003****Electrical Characteristics (Continued)
For All Output Voltage Versions**

Unless otherwise specified, $V_{IN}=12V$ for 3.3V, 5V and adjustable version, $V_{IN}=24V$ for 12V version, $I_{LOAD}=500mA$, $T_J=25^{\circ}C$. Specifications with **boldface type** apply over Full Operating Junction Temperature Range.

Parameter	Symbol	Conditions	Min	Typ	Max	Unit
Feedback Bias Current	I_{FB}	Adjustable Version Only, $V_{FB}=1.3V$		10	50 100	nA
Oscillator Frequency	f	(Note 3)	127 110	150	173 173	kHz
Saturation Voltage	V_{SAT}	$I_{LOAD}=3A$ (No output devices, $V_{FB}=0V$)		1.2	1.5 1.6	V
Maximum Duty Cycle	D_{MAX}	$V_{FB}=0V$		100		%
Minimum Duty Cycle	D_{MIN}	$V_{FB}=1.3V$		0		%
Current Limit	I_{CL}	Peak Current , No output devices, $V_{FB}=0V$	3.6 3.4	4.5	6.9 7.5	A
Output Leakage Current	I_{SWL}	Output=0V, No output devices, $V_{FB}=1.3V$, $V_{IN}=32V$		50		μA
		Output=-1V, No output devices, $V_{FB}=1.3V$, $V_{IN}=32V$		2	30	mA
Quiescent Current	I_Q	$V_{FB}=1.3V$		5	10	mA
Standby Quiescent Current	I_{STBY}	$\overline{ON/OFF}$ Pin=5V, $V_{IN}=18V$		80	200 250	μA
$\overline{ON/OFF}$ Pin Logic Input Threshold Voltage	V_{IL}	Regulator ON			0.6	V
	V_{IH}	Regulator OFF	2.0			
$\overline{ON/OFF}$ Pin Input Current	I_H	$V_{PIN5}=2.5V$ (Regulator OFF)		5	15	μA
	I_L	$V_{PIN5}=0.5V$ (Regulator ON)		0.02	5	μA

Note 3: The switching frequency is reduced when the second stage current limit is activated.

Note 4: The specifications with boldface are GBD (Guaranteed By Design).



Typical Performance Characteristics

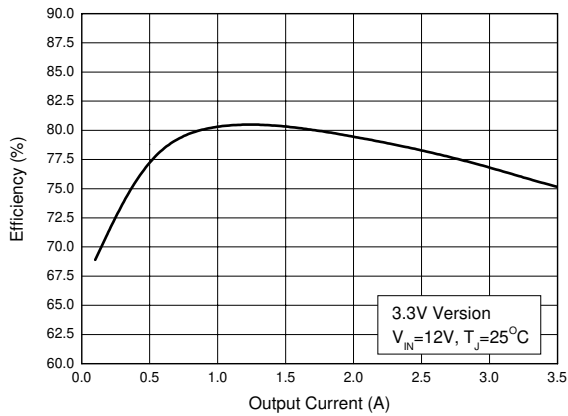

Figure 4. Efficiency vs. Output Current

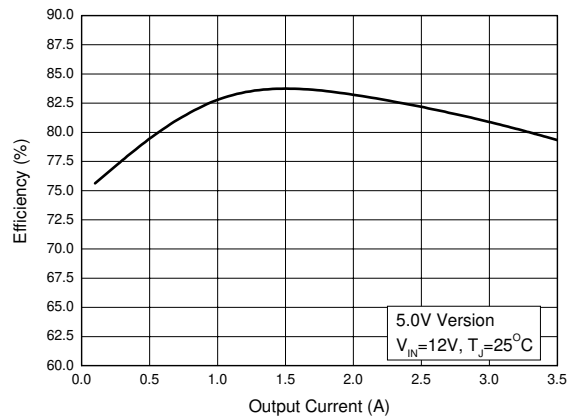

Figure 5. Efficiency vs. Output Current

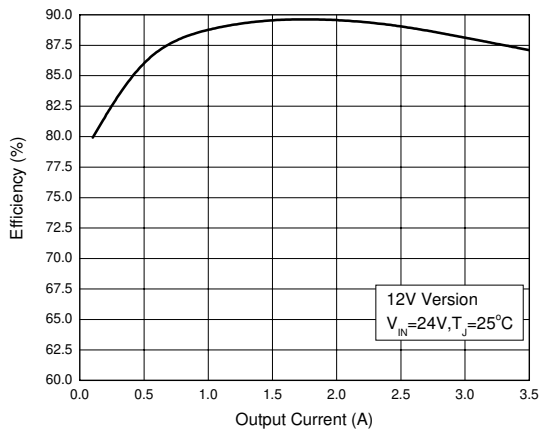

Figure 6. Efficiency vs. Output Current

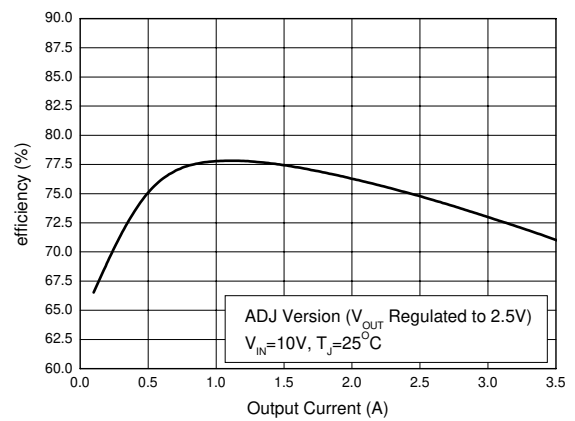

Figure 7. Efficiency vs. Output Current



150kHz 3A BUCK DC-DC CONVERTER

AP3003

Typical Performance Characteristics (Continued)

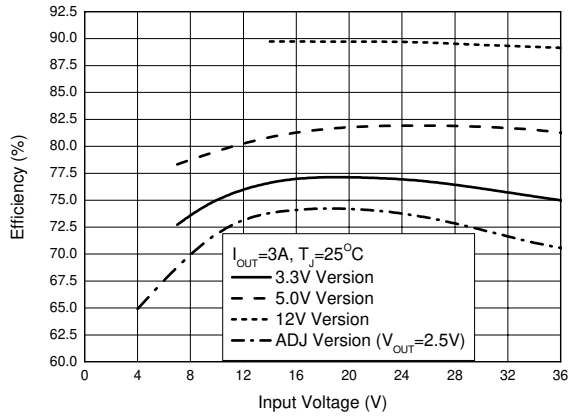

Figure 8. Efficiency vs. Input Voltage

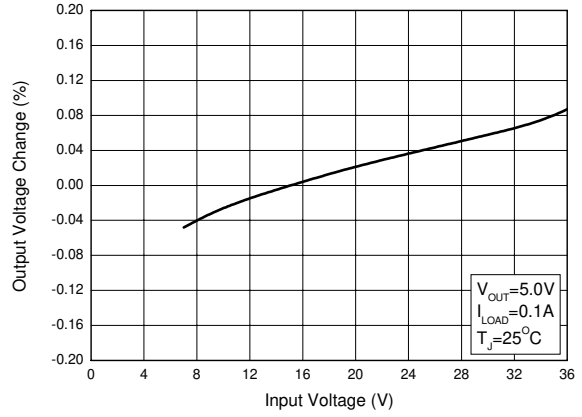

Figure 9. Line Regulation

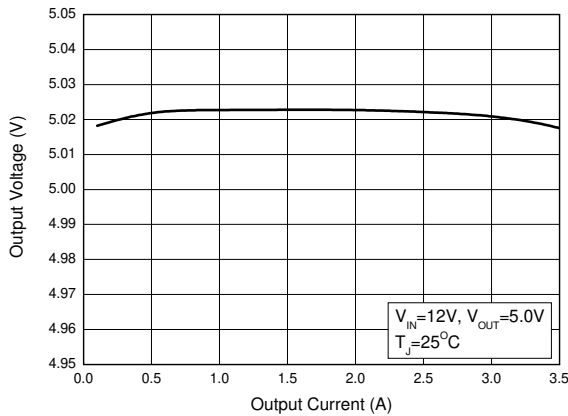

Figure 10. Load Regulation

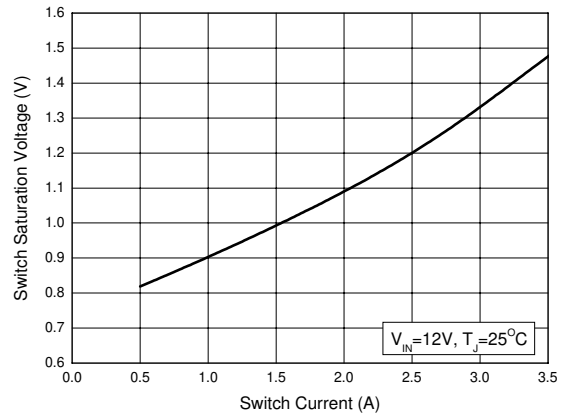

Figure 11. Switch Saturation Voltage vs. Switch Current



150kHz 3A BUCK DC-DC CONVERTER

AP3003

Typical Performance Characteristics (Continued)

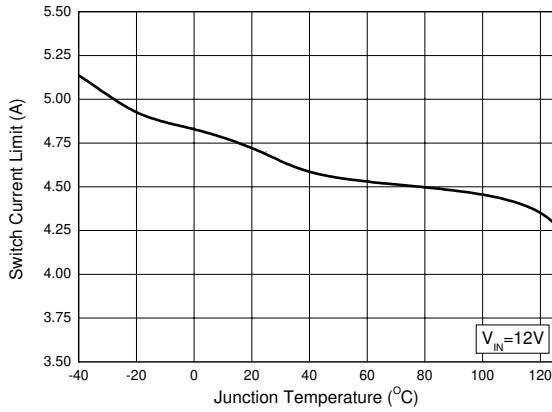

Figure 12. Switch Current Limit vs. Junction Temperature

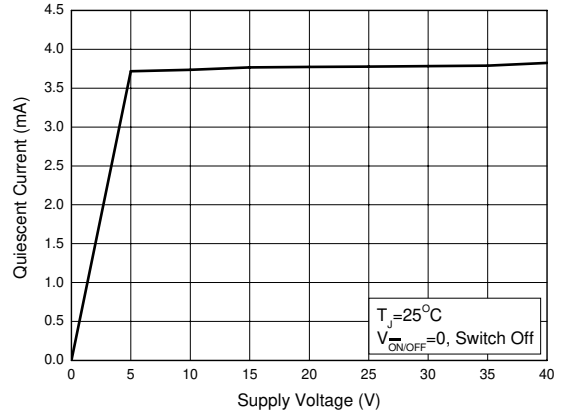

Figure 13. Quiescent Current vs. Supply Voltage

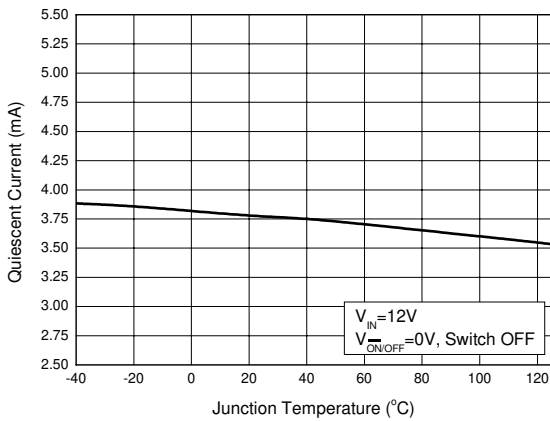

Figure 14. Quiescent Current vs. Junction Temperature

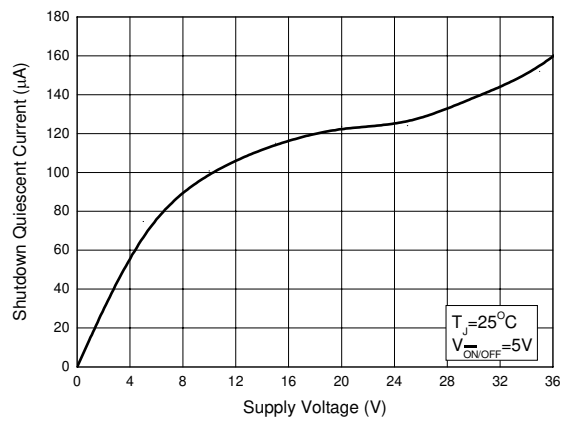

Figure 15. Shutdown Quiescent Current vs. Input Voltage



150kHz 3A BUCK DC-DC CONVERTER

AP3003

Typical Performance Characteristics (Continued)

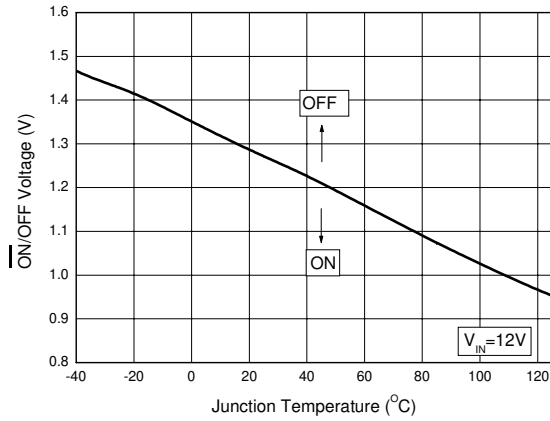

Figure 16. On/Off Threshold Voltage vs. Junction Temperature

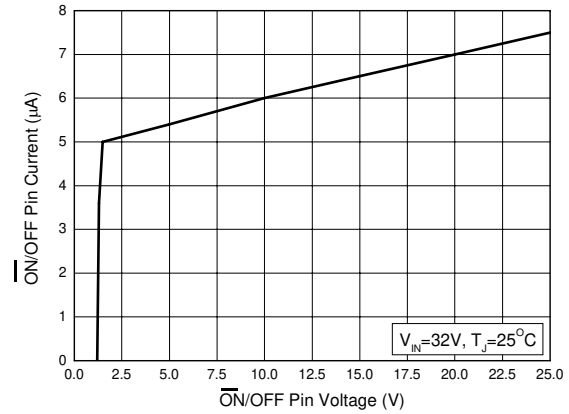

Figure 17. On/Off Pin Current vs. On/Off Pin Voltage

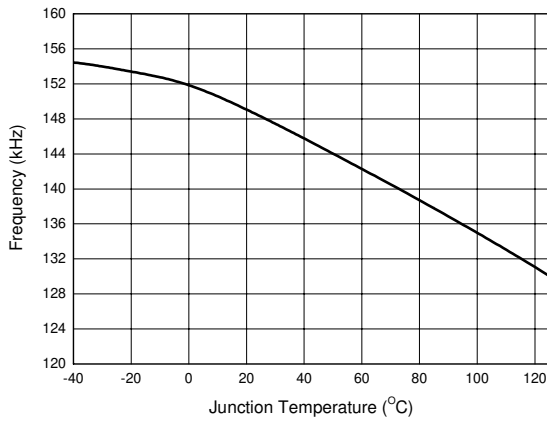
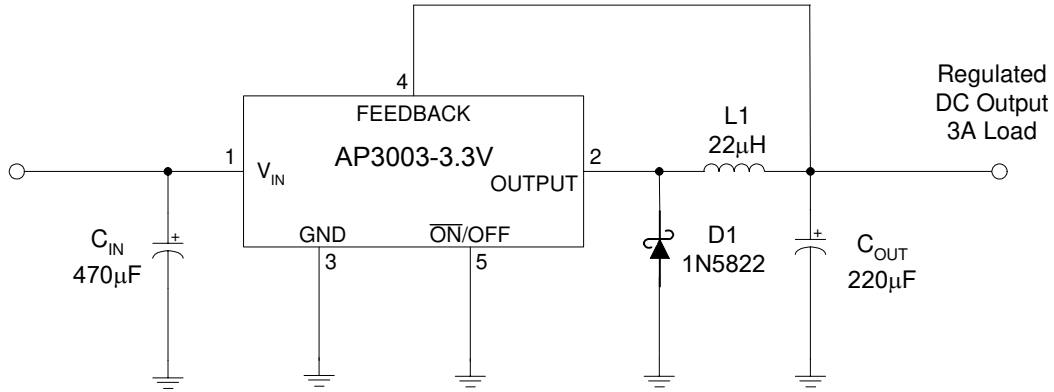

Figure 18. Switching Frequency vs. Junction Temperature

150kHz 3A BUCK DC-DC CONVERTER

AP3003

Typical Application



L1: Sumida CDRH127/LDNP-220MC or Equivalent

Figure 19. Typical Application of AP3003-3.3V

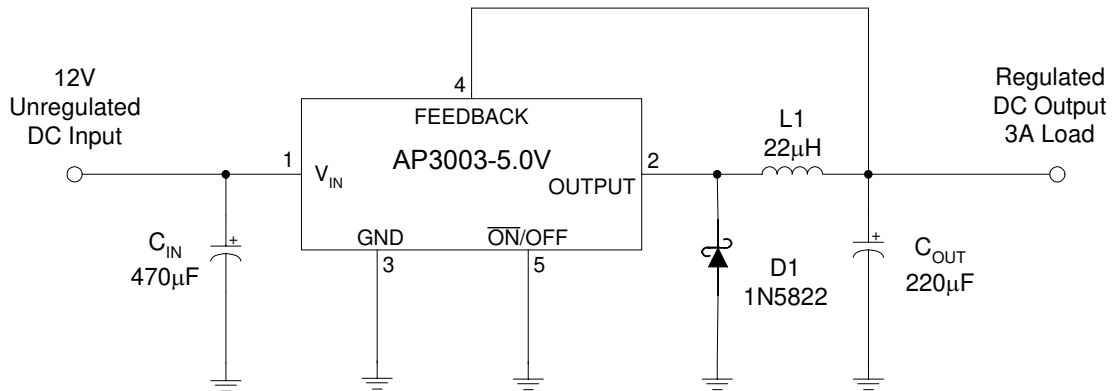

L1: Sumida CDRH127/LDNP-220MC or Equivalent

Figure 20. Typical Application of AP3003-5.0V

150kHz 3A BUCK DC-DC CONVERTER

AP3003

Typical Application (Continued)

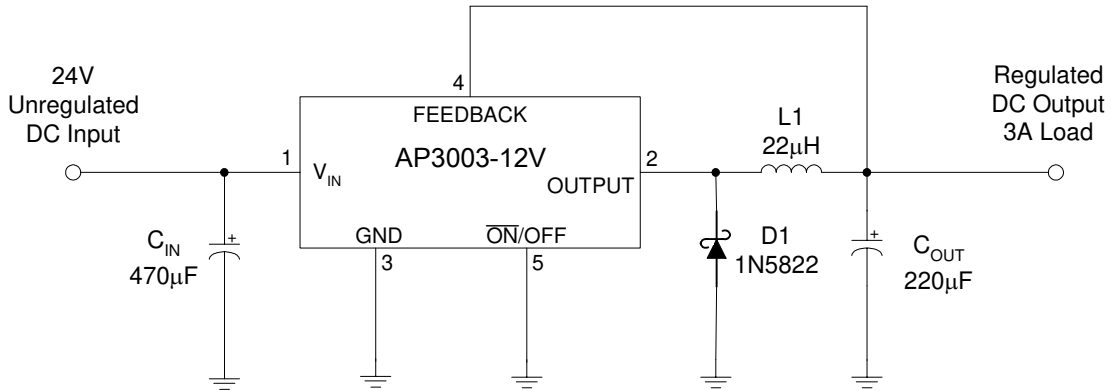

L1: Sumida CDRH127/LDNP-220MC or Equivalent

Figure 19. Typical Application of AP3003-12V

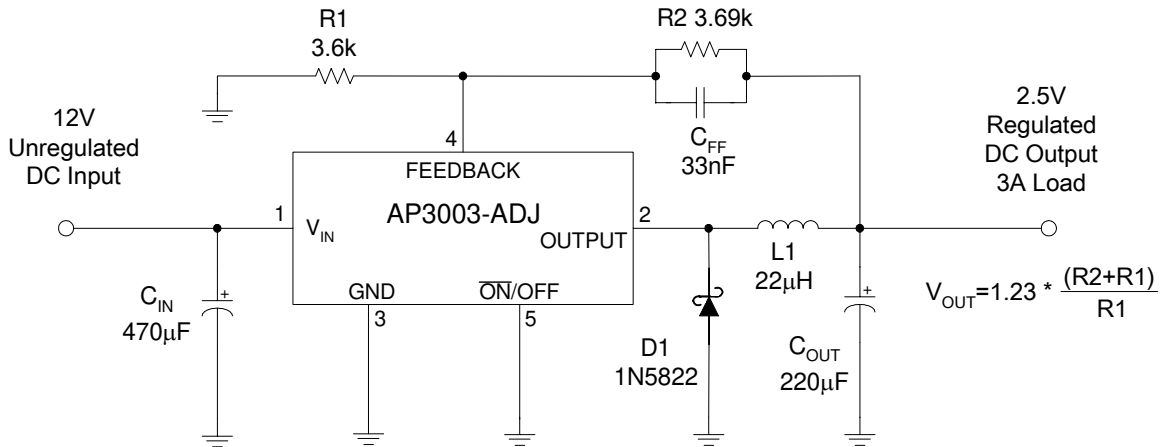

L1: Sumida CDRH127/LDNP-220MC or Equivalent

Figure 20. Typical Application of AP3003-ADJ



150kHz 3A BUCK DC-DC CONVERTER

AP3003

Mechanical Dimensions

TO-220-5

Unit: mm(inch)

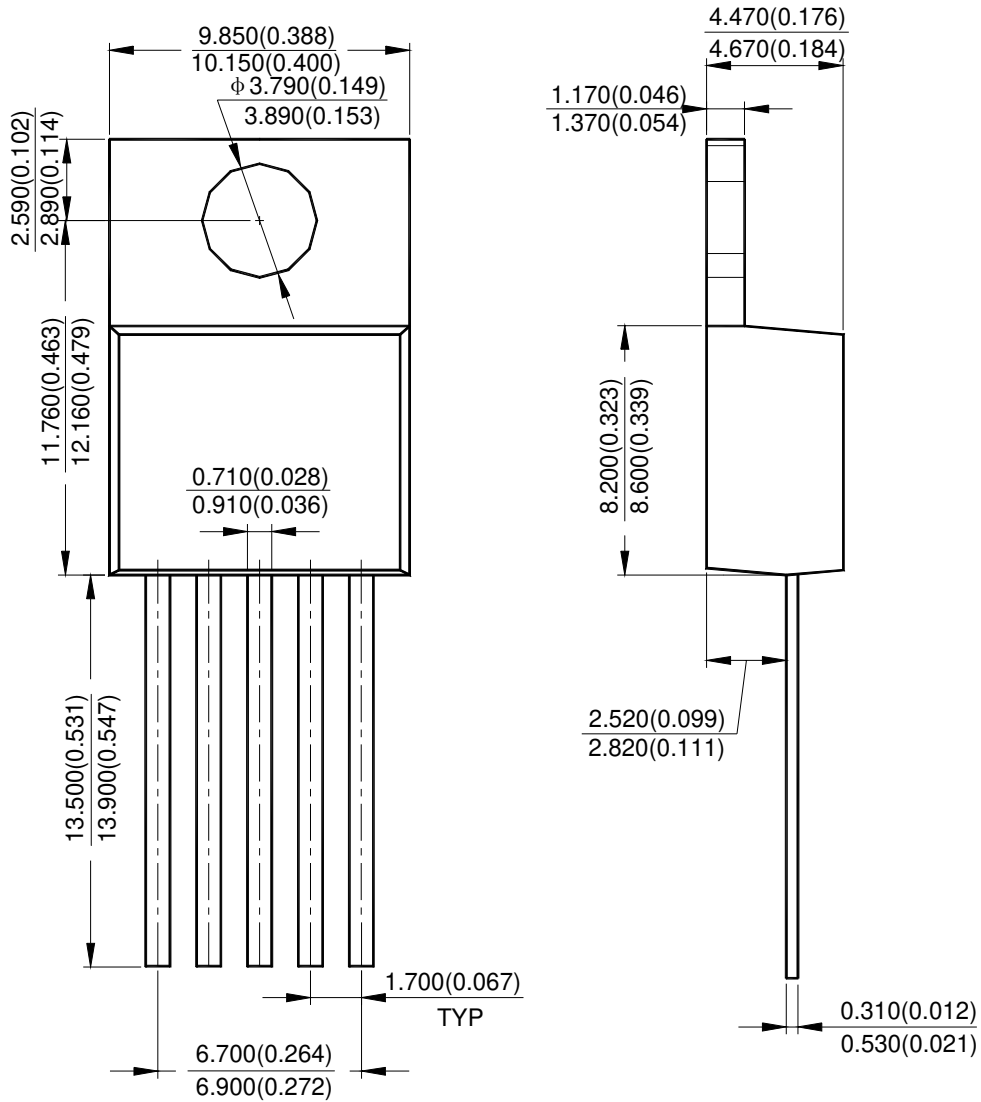



150kHz 3A BUCK DC-DC CONVERTER

AP3003

Mechanical Dimensions (Continued)

TO-263-5

Unit: mm(inch)

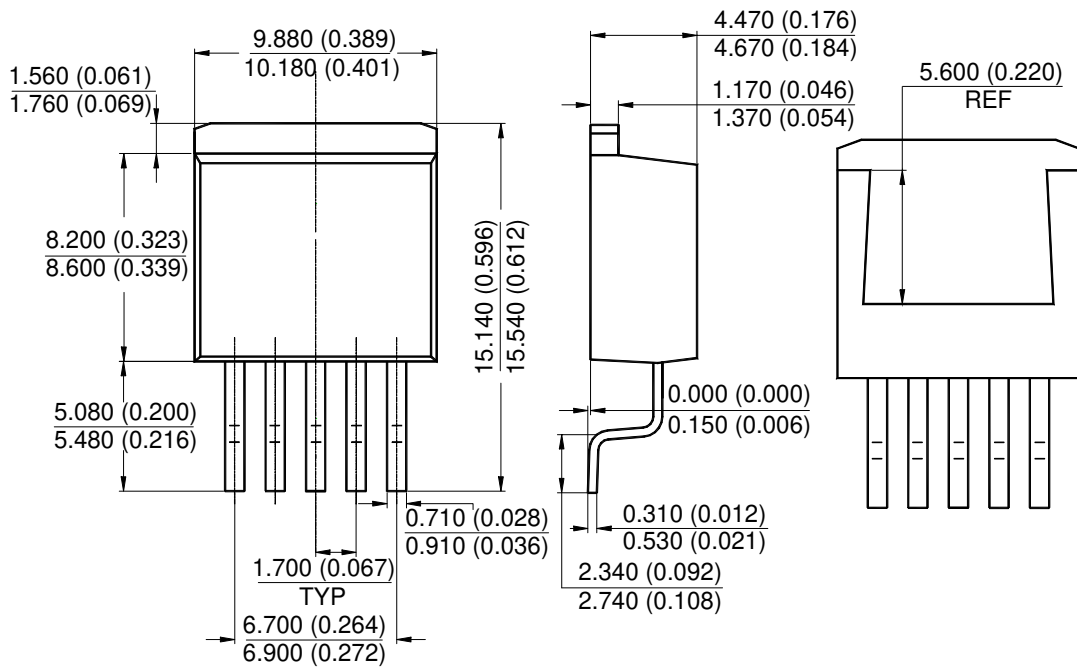



BCD Semiconductor Manufacturing Limited

<http://www.bcdsemi.com>

IMPORTANT NOTICE

BCD Semiconductor Manufacturing Limited reserves the right to make changes without further notice to any products or specifications herein. BCD Semiconductor Manufacturing Limited does not assume any responsibility for use of any its products for any particular purpose, nor does BCD Semiconductor Manufacturing Limited assume any liability arising out of the application or use of any its products or circuits. BCD Semiconductor Manufacturing Limited does not convey any license under its patent rights or other rights nor the rights of others.

MAIN SITE

- Headquarters

BCD Semiconductor Manufacturing Limited

No. 1600, Zi Xing Road, Shanghai ZiZhu Science-based Industrial Park, 200241, China
Tel: +86-21-24162266, Fax: +86-21-24162277

- Wafer Fab

Shanghai SIM-BCD Semiconductor Manufacturing Co., Ltd.

800 Yi Shan Road, Shanghai 200233, China
Tel: +86-21-6485 1491, Fax: +86-21-5450 0008

REGIONAL SALES OFFICE

Shenzhen Office

Shanghai SIM-BCD Semiconductor Manufacturing Co., Ltd., Shenzhen Office

Unit A Room 1203, Skyworth Bldg., Gaoxin Ave. 1.S., Nanshan District, Shenzhen, China
Tel: +86-755-8826 7951
Fax: +86-755-8826 7865

Taiwan Office

BCD Semiconductor (Taiwan) Company Limited

4F, 298-1, Rui Guang Road, Nei-Hu District, Taipei, Taiwan
Tel: +886-2-2656 2808
Fax: +886-2-2656 2806

USA Office

BCD Semiconductor Corp.

30920 Huntwood Ave. Hayward, CA 94544, USA
Tel : +1-510-324-2988
Fax: +1-510-324-2788