

Resonant-Mode Power Supply Controllers

FEATURES

- Controls Zero Current Switched (ZCS) or Zero Voltage Switched (ZVS) Quasi-Resonant Converters
- Zero-Crossing Terminated One-Shot Timer
- Precision 1%, Soft-Started 5V Reference
- Programmable Restart Delay Following Fault
- Voltage-Controlled Oscillator (VCO) with Programmable Minimum and Maximum Frequencies from 10kHz to 1MHz
- Low Start-Up Current (150µA typical)
- Dual 1 Amp Peak FET Drivers
- UVLO Option for Off-Line or DC/DC Applications

DESCRIPTION

The UC1861-1868 family of ICs is optimized for the control of Zero Current Switched and Zero Voltage Switched quasi-resonant converters. Differences between members of this device family result from the various combinations of UVLO thresholds and output options. Additionally, the one-shot pulse steering logic is configured to program either on-time for ZCS systems (UC1865-1868), or off-time for ZVS applications (UC1861-1864).

The primary control blocks implemented include an error amplifier to compensate the overall system loop and to drive a voltage controlled oscillator (VCO), featuring programmable minimum and maximum frequencies. Triggered by the VCO, the one-shot generates pulses of a programmed maximum width, which can be modulated by the Zero Detection comparator. This circuit facilitates "true" zero current or voltage switching over various line, load, and temperature changes, and is also able to accommodate the resonant components' initial tolerances.

Under-Voltage Lockout is incorporated to facilitate safe starts upon power-up. The supply current during the under-voltage lockout period is typically less than 150µA, and the outputs are actively forced to the low state.

(continued)

Device	1861	1862	1863	1864	1865	1866	1867	1868
UVLO	16.5/10.5	16.5/10.5	8/7	8/7	16.5/10.5	16.5/10.5	8/7	8/7
Outputs	Alternating	Parallel	Alternating	Parallel	Alternating	Parallel	Alternating	Parallel
"Fixed"	Off Time	Off Time	Off Time	Off Time	On Time	On Time	On Time	On Time

BLOCK DIAGRAM

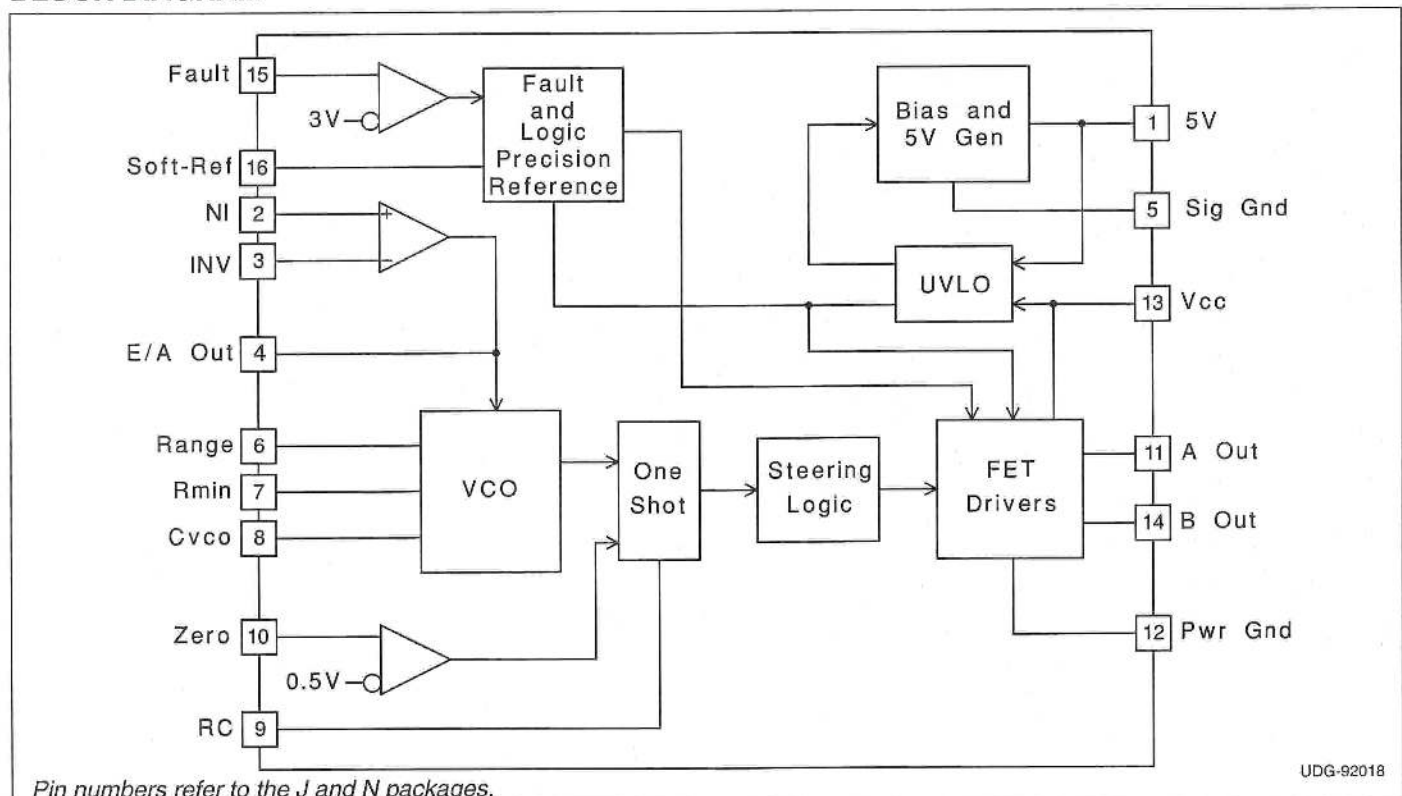

Pin numbers refer to the J and N packages.

UDG-92018

DESCRIPTION (cont.)

UVLO thresholds for the UC1861/62/65/66 are 16.5V (ON) and 10.5V (OFF), whereas the UC1863/64/67/68 thresholds are 8V (ON) and 7V (OFF). After V_{CC} exceeds the UVLO threshold, a 5V generator is enabled which provides bias for the internal circuits and up to 10mA for external usage.

A Fault comparator serves to detect fault conditions and set a latch while forcing the output drivers low. The Soft-Ref pin serves three functions: providing soft start, restart

delay, and the internal system reference.

Each device features dual 1 Amp peak totem pole output drivers for direct interface to power MOSFETS. The outputs are programmed to alternate in the UC1861/63/65/67 devices. The UC1862/64/66/68 outputs operate in unison allowing a 2 Amp peak current.

ABSOLUTE MAXIMUM RATINGS

V_{CC}	22V
Output Current	
Source or Sink (Pins 11 & 14)	0.5A
DC Pulse (0.5 μ s)	1.5A
Power Ground Voltage	$\pm 0.2V$
Inputs (Pins 2, 3, 10, & 15)	-0.4 to 7V
Error Amp Output Current	$\pm 2mA$
Power Dissipation	1W
Junction Temperature (Operating)	150°C
Lead Temperature (Soldering, 10 seconds)	300°C

All voltages are with respect to signal ground and all currents are positive into the specified terminal. Pin numbers refer to the J and N packages. Consult Unitrode Integrated Circuits databook for information regarding thermal specifications and limitations of packages.

CONNECTION DIAGRAMS

**PLCC-20 & LCC-20 (Top View)
 Q & L Package**

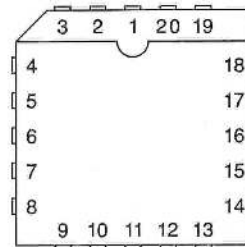

PACKAGE PIN FUNCTION	
FUNCTION	PIN
Soft Ref	1
5V	2
NI	3
INV	4
E/A Out	5
Sig Gnd	6
Range	7
RMIN	8
Cvco	9
RC	10
Zero	11
NC	12
NC	13
A Out	14
Pwr Gnd	15
Pwr Gnd	16
Vcc	17
B Out	18
NC	19
Fault	20

**DIL-16, SOIC-16 (Top View)
 J or N, DW Packages**

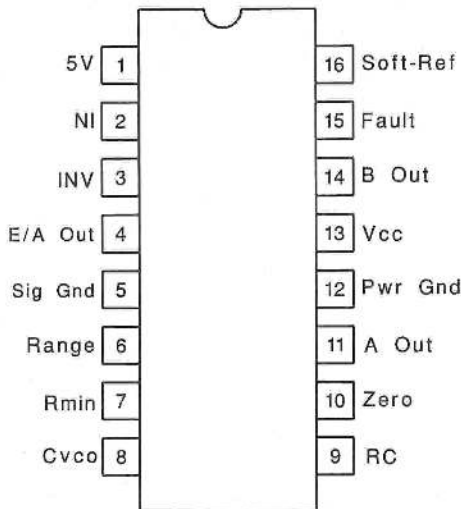

ELECTRICAL CHARACTERISTICS Unless otherwise stated, all specifications apply for $-55^{\circ}\text{C} \leq T_A \leq 125^{\circ}\text{C}$ for the UC186x, $-25^{\circ}\text{C} \leq T_A \leq 85^{\circ}\text{C}$ for the UC286x, and $0^{\circ}\text{C} \leq T_A \leq 70^{\circ}\text{C}$ for the UC386x, $V_{CC}=12\text{V}$, $C_{VCO}=1\text{nF}$, $\text{Range}=7.15\text{k}$, $R_{\text{MIN}}=86.6\text{k}$, $C=200\text{pF}$, $R=4.02\text{k}$, and $C_{sr}=0.1\mu\text{F}$. $T_A=T_J$.

PARAMETER	TEST CONDITIONS	MIN	TYP	MAX	UNITS
5V Generator					
Output Voltage	$12\text{V} \leq V_{CC} \leq 20\text{V}$, $-10\text{mA} \leq I_O \leq 0\text{mA}$	4.8	5.0	5.2	V
Short Circuit Current	$V_O = 0\text{V}$	-150		-15	mA
Soft-Reference					
Restart Delay Current	$V = 2\text{V}$	10	20	35	μA
Soft Start Current	$V = 2\text{V}$	-650	-500	-350	μA
Reference Voltage	$T_J = 25^{\circ}\text{C}$, $I_O = 0\text{A}$	4.95	5.00	5.05	V
	$12\text{V} \leq V_{CC} \leq 20\text{V}$, $-200\mu\text{A} \leq I_O \leq 200\mu\text{A}$	4.85		5.15	V
Line Regulation	$12\text{V} \leq V_{CC} \leq 20\text{V}$		2	20	mV
Load Regulation	$-200\mu\text{A} \leq I_O \leq 200\mu\text{A}$		10	30	mV
Error Amplifier (Note 3)					
Input Offset Voltage	$V_{CM} = 5\text{V}$, $V_O = 2\text{V}$, $I_O = 0\text{A}$	-10		10	mV
Input Bias Current	$V_{CM} = 0\text{V}$	-2.0	-0.3		μA
Voltage Gain	$V_{cm} = 5\text{V}$, $0.5\text{V} \leq V_O \leq 3.7\text{V}$, $I_O = 0\text{A}$	70	100		dB
Power Supply Rejection Ratio	$V_{cm} = 5\text{V}$, $V_O = 2\text{V}$, $12\text{V} \leq V_{CC} \leq 20\text{V}$	70	100		dB
Error Amplifier (Note 3) (cont.)					
Common Mode Rejection Ratio	$0\text{V} \leq V_{cm} \leq 6\text{V}$, $V_O = 2\text{V}$	65	100		dB
V _{OUT} Low	$V_{ID} = -100\text{mV}$, $I_O = 200\mu\text{A}$		0.17	0.25	V
V _{OUT} High	$V_{ID} = 100\text{mV}$, $I_O = -200\mu\text{A}$	3.9	4.2		V
Unity Gain Bandwidth	(Note 4)	0.5	0.8		MHz
Voltage Controlled Oscillator					
Maximum Frequency	V_{ID} (Error Amp) = 100mV, $T_J = 25^{\circ}\text{C}$	450	500	550	kHz
	V_{ID} (Error Amp) = 100mV	425		575	kHz
Minimum Frequency	V_{ID} (Error Amp) = -100mV, $T_J = 25^{\circ}\text{C}$	45	50	55	kHz
	V_{ID} (Error Amp) = -100mV	42		58	kHz
One Shot					
Zero Comparator V _{th}		0.45	0.50	0.55	V
Propagation Delay	(Note 4)		120	200	ns
Maximum Pulse Width	$V_{ZERO} = 1\text{V}$	850	1000	1150	ns
Maximum to Minimum Pulse Width Ratio	$V_{ZERO} = 0\text{V}$ UCx861 – UCx864	2.5	4	5.5	
	$V_{ZERO} = 0\text{V}$ UCx865 – UCx868, -55°C to $+85^{\circ}\text{C}$	4	5.5	7	
	$V_{ZERO} = 0\text{V}$ UCx865 – UCx868, $+125^{\circ}\text{C}$	3.8	5.5	7	
Output Stage					
Rise and Fall Time	$C_{LOAD} = 1\text{nF}$ (Note 4)		25	45	ns
Output Low Saturation	$I_O = 20\text{mA}$		0.2	0.5	V
	$I_O = 200\text{mA}$		0.5	2.2	V
Output High Saturation	$I_O = -200\text{mA}$, down from V_{CC}		1.7	2.5	V
UVLO Low Saturation	$I_O = 20\text{mA}$		0.8	1.5	V
Fault Comparator					
Fault Comparator V _{th}		2.85	3.00	3.15	V
Delay to Output	(Note 4) (Note 5)		100	200	ns

ELECTRICAL CHARACTERISTICS Unless otherwise stated, all specifications apply for $-55^{\circ}\text{C} \leq T_A \leq 125^{\circ}\text{C}$ for the UC186x, $-25^{\circ}\text{C} \leq T_A \leq 85^{\circ}\text{C}$ for the UC286x, and $0^{\circ}\text{C} \leq T_A \leq 70^{\circ}\text{C}$ for the UC386x, $V_{CC}=12\text{V}$, $C_{VCO}=1\text{nF}$, $\text{Range}=7.15\text{k}$, $R_{\text{MIN}}=86.6\text{k}$, $C=200\text{pF}$, $R=4.02\text{k}$, and $C_{\text{sr}}=0.1\mu\text{F}$. $T_A=T_J$.

PARAMETER	TEST CONDITIONS	MIN	TYP	MAX	UNITS
UVLO					
Vcc Turn-on Threshold	UCx861, UCx862, UCx865, UCx866	15	16.5	18	V
	UCx863, UCx864, UCx867, UCx868	7	8.0	9	V
Vcc Turn-off Threshold	UCx861, UCx862, UCx865, UCx866	9.5	10.5	11.5	V
	UCx863, UCx864, UCx867, UCx868	6	7.0	8	V
Icc Start	$V_{CC} = V_{CC(\text{on})} - 0.3\text{V}$		150	300	μA
Icc Run	$V_{\text{ID}} = 100\text{mV}$		25	32	mA

Note 1: Currents are defined as positive into the pin.

Note 2: Pulse measurement techniques are used to insure that $T_J = T_A$.

Note 3: $V_{\text{ID}} = V(\text{NI}) - V(\text{INV})$.

Note 4: This parameter is not 100% tested in production but guaranteed by design.

Note 5: $V_i = 0$ to 4V $t_r(V_i) = 10\text{ns}$ $t_{pd} = t(V_o = 6\text{V}) - t(V_i = 3\text{V})$

APPLICATION INFORMATION

UVLO & 5V GENERATOR (See Figure 1): When power is applied to the chip and V_{CC} is less than the upper UVLO threshold, I_{CC} will be less than $300\mu\text{A}$, the 5V generator will be off, and the outputs will be actively held low.

When V_{CC} exceeds the upper UVLO threshold, the 5V generator turns on. Until the 5V pin exceeds 4.9V , the outputs will still remain low.

The 5V pin should be bypassed to signal ground with a $0.1\mu\text{F}$ capacitor. The capacitor should have low equivalent series resistance and inductance.

FAULT AND SOFT-REFERENCE (See Figure 1): The Soft-Ref pin serves three functions: system reference, restart delay, and soft-start. Designed to source or sink $200\mu\text{A}$, this pin should be used as the input reference for the error amplifier circuit. This pin requires a bypass capacitor of at least $0.1\mu\text{F}$. This yields a minimum soft-start time of 1ms .

Under-Voltage Lockout sets both the fault and restart delay latches. This holds the outputs low and discharges the Soft-Ref pin. After UVLO, the fault latch is reset by the low voltage on the Soft-Ref pin. The reset fault latch resets the delay latch and Soft-Ref charges via the 0.5mA current source.

The fault pin is input to a high speed comparator with a threshold of 3V . In the event of a detected fault, the fault latch is set and the outputs are driven low. If Soft-Ref is above 4V , the delay latch is set. Restart delay is timed as Soft-Ref is discharged by $20\mu\text{A}$. When Soft-Ref is fully discharged, the fault latch is reset if the fault input signal is low. The Fault pin can be used as a system shutdown pin.

If a fault is detected during soft-start, the fault latch is set and the outputs are driven low. The delay latch will remain reset until Soft-Ref charges to 4V . This sets the delay latch, and restart delay is timed. Note that restart delay for a single fault event is longer than for recurring faults since Soft-Ref must be discharged from 5V instead of 4V .

The restart delay to soft-start time ratio is 24:1 for a fault occurring during normal operation and 19:1 for faults occurring during soft-start. Shorter ratios can be programmed down to a limit of approximately 3:1 by the addition of a $20\text{k}\Omega$ or larger resistor from Soft-Ref to ground.

A $100\text{k}\Omega$ resistor from Soft-Ref to 5V will have the effect of permanent shut down after a fault since the internal $20\mu\text{A}$ current source can't pull Soft-Ref low. This feature can be used to require recycling V_{CC} after a fault. Care must be taken to insure Soft-Ref is indeed low at start up, or the fault latch will never be reset.

APPLICATION INFORMATION

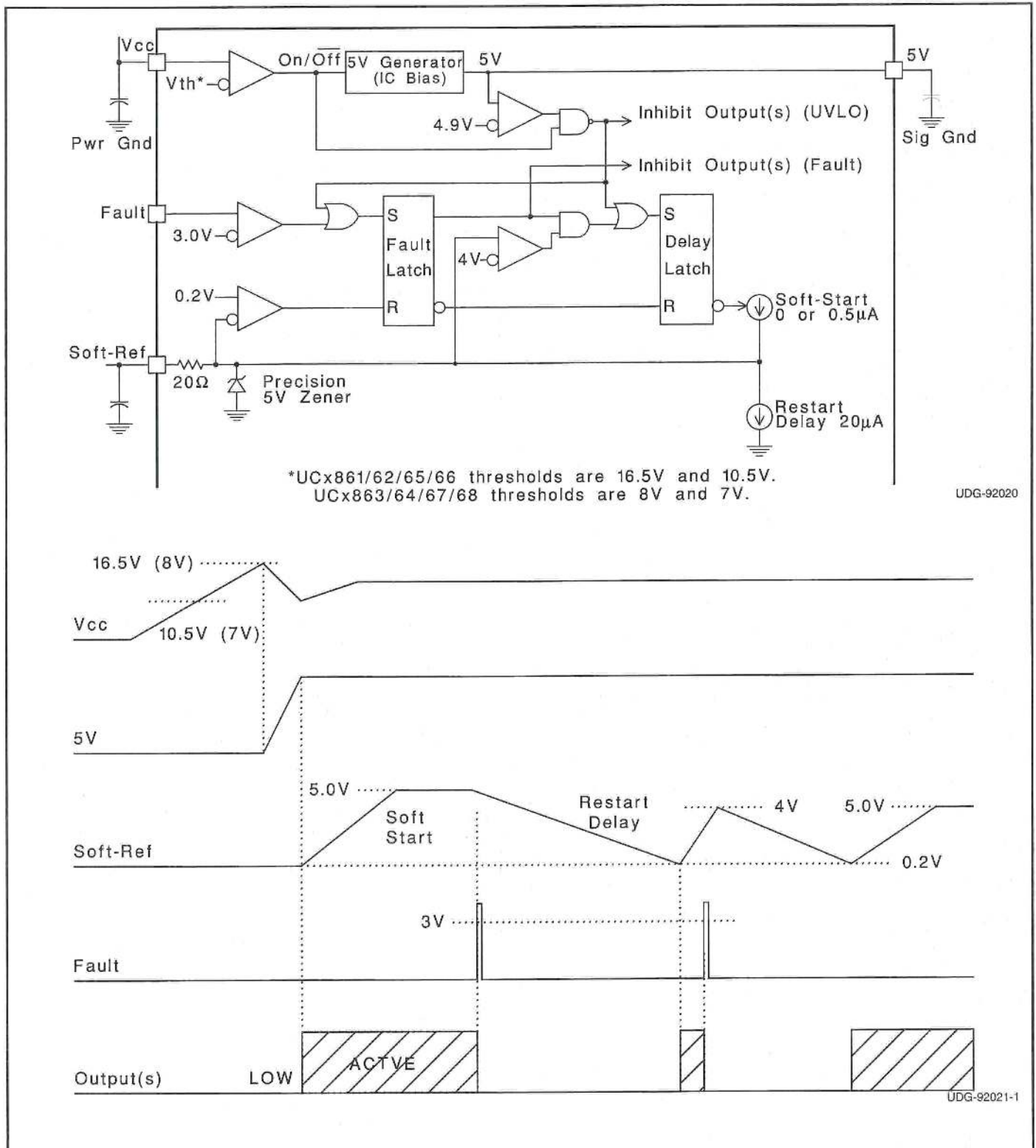
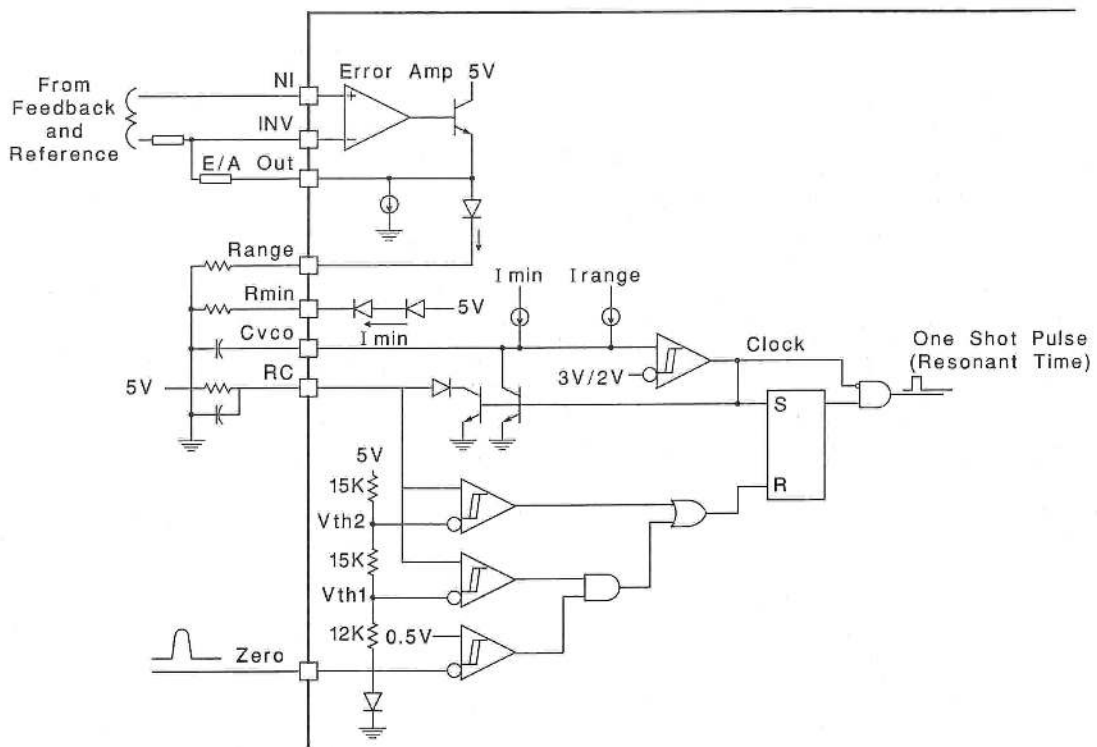
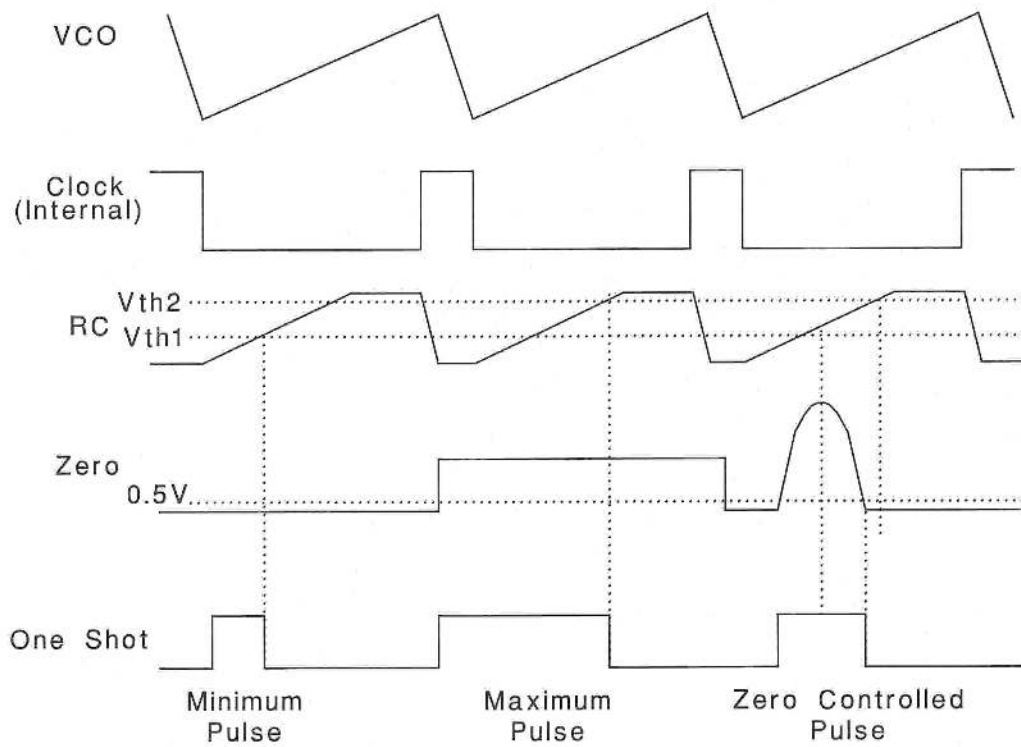

Figure 1. UVLO, 5V, fault and soft-ref.



UDG-92022-1



UDG-92023-1

Figure 2. Error Amp, Voltage Controlled Oscillator, and One Shot

APPLICATION INFORMATION

Minimum oscillator frequency is set by R_{min} and C_{VCO} . The minimum frequency is approximately given by the equation:

$$F_{MIN} \cong \frac{3.6}{R_{MIN} \cdot C_{VCO}}$$

Maximum oscillator frequency is set by R_{min} , Range & C_{VCO} . The maximum frequency is approximately given by the equation:

$$F_{MAX} \cong \frac{3.6}{(R_{MIN} // Range) \cdot C_{VCO}}$$

The Error Amplifier directly controls the oscillator frequency. E/A output low corresponds to minimum frequency and output high corresponds to maximum frequency. At the end of each oscillator cycle, the RC pin is discharged to one diode drop above ground. At the beginning of the oscillator cycle, $V(RC)$ is less than V_{th1} and so the output of the zero detect comparator is ignored. After $V(RC)$ exceeds V_{th1} , the one shot pulse will be terminated as soon as the zero pin falls below 0.5V or $V(RC)$ exceeds V_{th2} . The minimum one shot pulse width is approximately given by the equation:

$$Tp_{w(min)} \cong 0.3 R C.$$

The maximum pulse width is approximately given by:

$$Tp_{w(max)} \cong 1.2 R C.$$

STEERING LOGIC

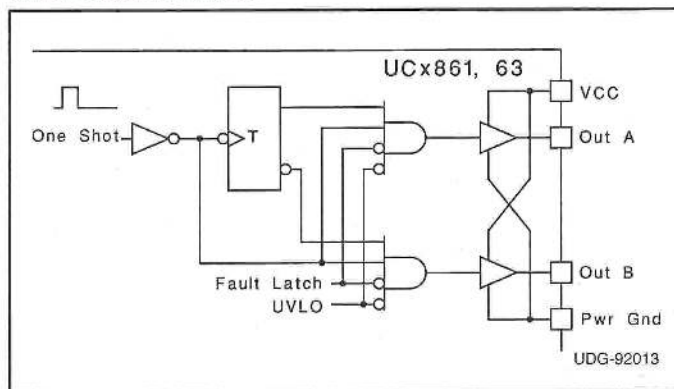

The steering logic is configured on the UC1861,63 to result in dual non-overlapping square waves at outputs A & B. This is suited to drive dual switch ZVS systems.

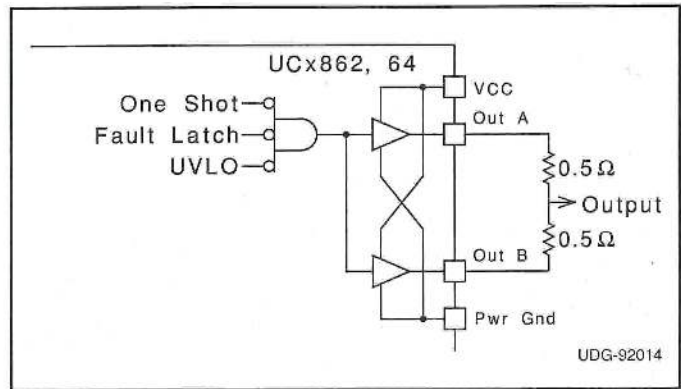

The steering logic is configured on the UC1862,64 to result in inverted pulse trains occurring identically at both output pins. This is suited to drive single switch ZVS systems. Both outputs are available to drive the same MOSFET gate. It is advisable to join the pins with 0.5 ohm resistors.

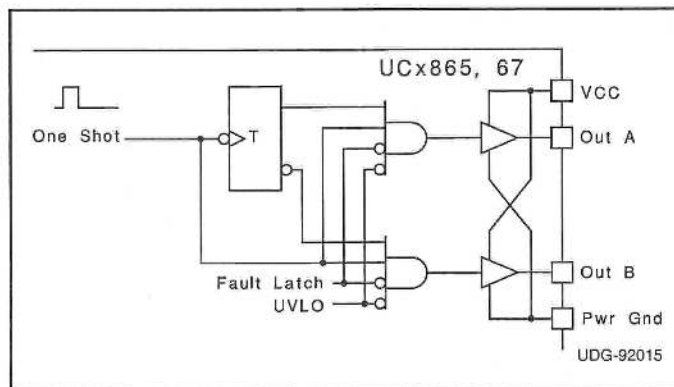

The steering logic is configured on the UC1865,67 to result in alternating pulse trains at outputs A & B. This is suited to drive dual switch ZCS systems.

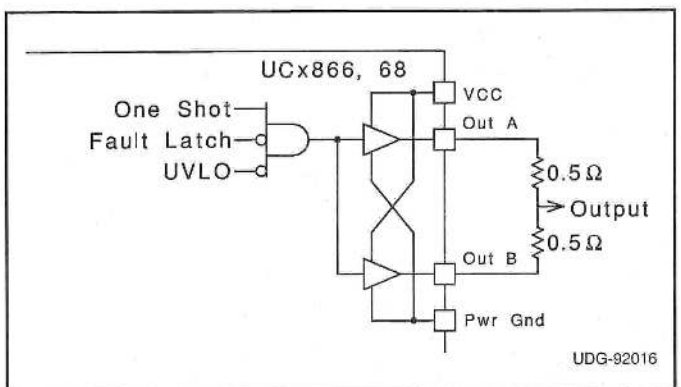

The steering logic is configured on the UC1866,68 to result in non-inverted pulse trains occurring identically at both output pins. This is suited to drive single switch ZCS systems. Both outputs are available to drive the same MOSFET gate. It is advisable to join the pins with 0.5 ohm resistors.

APPLICATION INFORMATION (cont.)

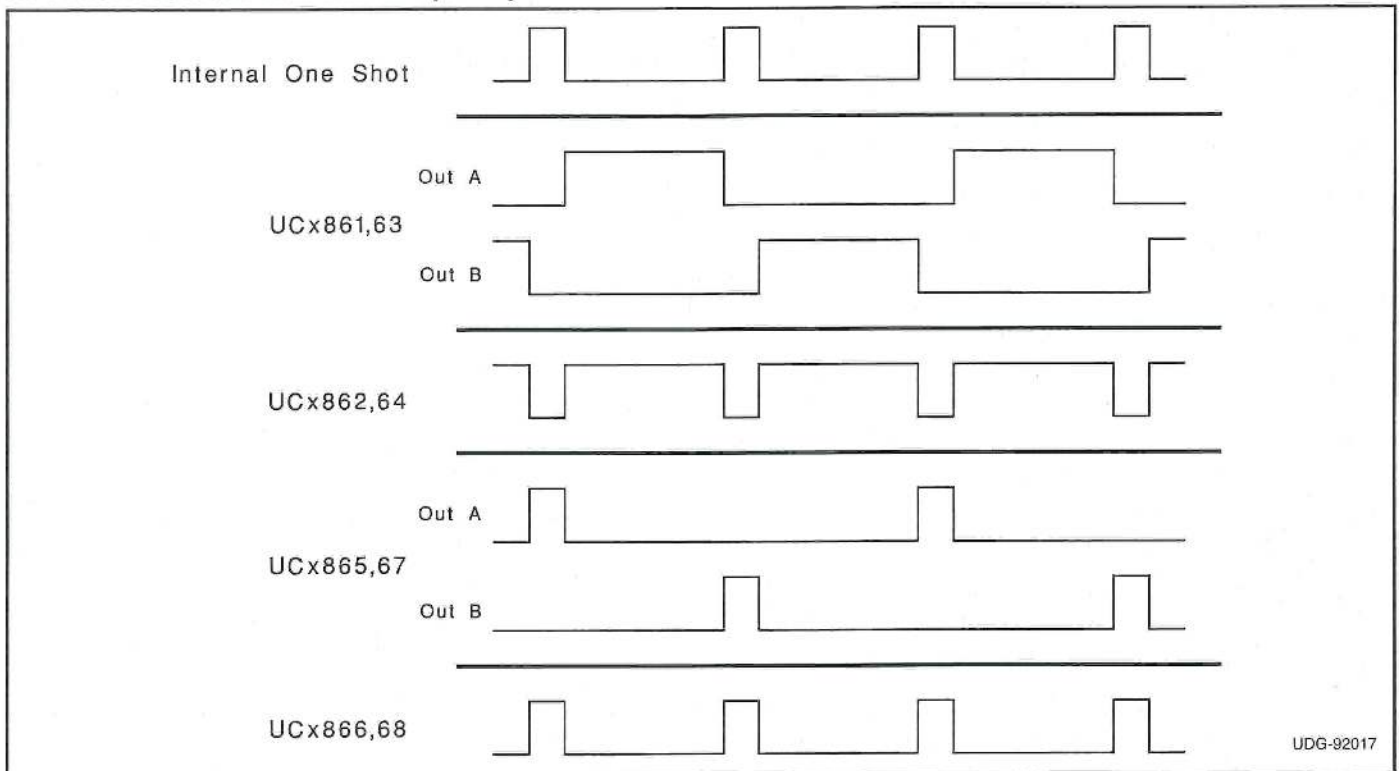

Figure 3. Current waveforms.

PACKAGING INFORMATION

Orderable Device	Status (1)	Package Type	Package Drawing	Pins	Package Qty	Eco Plan (2)	Lead/Ball Finish (6)	MSL Peak Temp (3)	Op Temp (°C)	Device Marking (4/5)	Samples
5962-9203101M2A	OBSOLETE	LCCC	FK	20		TBD	Call TI	Call TI	-55 to 125		
5962-9203101MEA	OBSOLETE	CDIP	J	16		TBD	Call TI	Call TI	-55 to 125		
5962-9203102MEA	OBSOLETE	CDIP	J	16		TBD	Call TI	Call TI	-55 to 125		
5962-9203103Q2A	ACTIVE	LCCC	FK	20	1	TBD	POST-PLATE	N / A for Pkg Type	-55 to 125	5962- 9203103Q2A UC1863L/ 883B	Samples
5962-9203103QEA	ACTIVE	CDIP	J	16	1	TBD	A42	N / A for Pkg Type	-55 to 125	5962-9203103QE A UC1863J/883B	Samples
5962-9203103V2A	ACTIVE	LCCC	FK	20	1	TBD	POST-PLATE	N / A for Pkg Type	-55 to 125	5962- 9203103V2A UC1863L QMLV	Samples
UC1861J	OBSOLETE	CDIP	J	16		TBD	Call TI	Call TI	-55 to 125		
UC1861J883B	OBSOLETE	CDIP	J	16		TBD	Call TI	Call TI	-55 to 125		
UC1863J	ACTIVE	CDIP	J	16	1	TBD	A42	N / A for Pkg Type	-55 to 125	UC1863J	Samples
UC1863J883B	ACTIVE	CDIP	J	16	1	TBD	A42	N / A for Pkg Type	-55 to 125	5962-9203103QE A UC1863J/883B	Samples
UC1863L	ACTIVE	LCCC	FK	20	1	TBD	POST-PLATE	N / A for Pkg Type	-55 to 125	UC1863L	Samples
UC1863L883B	ACTIVE	LCCC	FK	20	1	TBD	POST-PLATE	N / A for Pkg Type	-55 to 125	5962- 9203103Q2A UC1863L/ 883B	Samples
UC1864J	OBSOLETE	CDIP	J	16		TBD	Call TI	Call TI	-55 to 125		
UC1864J883B	OBSOLETE	CDIP	J	16		TBD	Call TI	Call TI	-55 to 125		
UC1864L	OBSOLETE	LCCC	FK	20		TBD	Call TI	Call TI	-55 to 125		
UC1864L883B	OBSOLETE	LCCC	FK	20		TBD	Call TI	Call TI	-55 to 125		
UC1865J	OBSOLETE	CDIP	J	16		TBD	Call TI	Call TI	-55 to 125		
UC1865J883B	OBSOLETE	CDIP	J	16		TBD	Call TI	Call TI	-55 to 125		
UC1867J	OBSOLETE	CDIP	J	16		TBD	Call TI	Call TI	-55 to 125		

Orderable Device	Status (1)	Package Type	Package Drawing	Pins	Package Qty	Eco Plan (2)	Lead/Ball Finish (6)	MSL Peak Temp (3)	Op Temp (°C)	Device Marking (4/5)	Samples
UC1867L	OBSOLETE	LCCC	FK	20		TBD	Call TI	Call TI	-55 to 125		
UC2861DW	ACTIVE	SOIC	DW	16	40	Green (RoHS & no Sb/Br)	CU NIPDAU	Level-2-260C-1 YEAR	-40 to 85	UC2861DW	Samples
UC2861DWG4	ACTIVE	SOIC	DW	16	40	Green (RoHS & no Sb/Br)	CU NIPDAU	Level-2-260C-1 YEAR	-40 to 85	UC2861DW	Samples
UC2861Q	ACTIVE	PLCC	FN	20	46	Green (RoHS & no Sb/Br)	CU SN	Level-2-260C-1 YEAR	-40 to 85	UC2861Q	Samples
UC2863DW	ACTIVE	SOIC	DW	16	40	Green (RoHS & no Sb/Br)	CU NIPDAU	Level-2-260C-1 YEAR	-40 to 85	UC2863DW	Samples
UC2863N	LIFEBUY	PDIP	N	16	25	Green (RoHS & no Sb/Br)	CU NIPDAU	N / A for Pkg Type	-40 to 85	UC2863N	
UC2864DW	ACTIVE	SOIC	DW	16	40	Green (RoHS & no Sb/Br)	CU NIPDAU	Level-2-260C-1 YEAR	-40 to 85	UC2864DW	Samples
UC2865N	LIFEBUY	PDIP	N	16	25	Green (RoHS & no Sb/Br)	CU NIPDAU	N / A for Pkg Type	-40 to 85	UC2865N	
UC2866N	LIFEBUY	PDIP	N	16	25	Green (RoHS & no Sb/Br)	CU NIPDAU	N / A for Pkg Type	-40 to 85	UC2866N	
UC2866NG4	LIFEBUY	PDIP	N	16	25	Green (RoHS & no Sb/Br)	CU NIPDAU	N / A for Pkg Type	-40 to 85	UC2866N	
UC3861DW	ACTIVE	SOIC	DW	16	40	Green (RoHS & no Sb/Br)	CU NIPDAU	Level-2-260C-1 YEAR	0 to 70	UC3861DW	Samples
UC3861DWG4	ACTIVE	SOIC	DW	16	40	Green (RoHS & no Sb/Br)	CU NIPDAU	Level-2-260C-1 YEAR	0 to 70	UC3861DW	Samples
UC3861N	ACTIVE	PDIP	N	16	25	Green (RoHS & no Sb/Br)	CU NIPDAU	N / A for Pkg Type	0 to 70	UC3861N	Samples
UC3861NG4	ACTIVE	PDIP	N	16	25	Green (RoHS & no Sb/Br)	CU NIPDAU	N / A for Pkg Type	0 to 70	UC3861N	Samples
UC3862N	LIFEBUY	PDIP	N	16	25	Green (RoHS & no Sb/Br)	CU NIPDAU	N / A for Pkg Type	0 to 70	UC3862N	
UC3863DW	ACTIVE	SOIC	DW	16	40	Green (RoHS & no Sb/Br)	CU NIPDAU	Level-2-260C-1 YEAR	0 to 70	UC3863DW	Samples
UC3863DWG4	ACTIVE	SOIC	DW	16	40	Green (RoHS & no Sb/Br)	CU NIPDAU	Level-2-260C-1 YEAR	0 to 70	UC3863DW	Samples
UC3863N	LIFEBUY	PDIP	N	16	25	Green (RoHS & no Sb/Br)	CU NIPDAU	N / A for Pkg Type	0 to 70	UC3863N	

Orderable Device	Status (1)	Package Type	Package Drawing	Pins	Package Qty	Eco Plan (2)	Lead/Ball Finish (6)	MSL Peak Temp (3)	Op Temp (°C)	Device Marking (4/5)	Samples
UC3864N	LIFEBUY	PDIP	N	16	25	Green (RoHS & no Sb/Br)	CU NIPDAU	N / A for Pkg Type	0 to 70	UC3864N	
UC3865DW	ACTIVE	SOIC	DW	16	40	Green (RoHS & no Sb/Br)	CU NIPDAU	Level-2-260C-1 YEAR	0 to 70	UC3865DW	Samples
UC3865N	LIFEBUY	PDIP	N	16	25	Green (RoHS & no Sb/Br)	CU NIPDAU	N / A for Pkg Type	0 to 70	UC3865N	
UC3865NG4	LIFEBUY	PDIP	N	16	25	Green (RoHS & no Sb/Br)	CU NIPDAU	N / A for Pkg Type	0 to 70	UC3865N	
UC3867DW	ACTIVE	SOIC	DW	16	40	Green (RoHS & no Sb/Br)	CU NIPDAU	Level-2-260C-1 YEAR	0 to 70	UC3867DW	Samples
UC3867DWTR	ACTIVE	SOIC	DW	16	2000	Green (RoHS & no Sb/Br)	CU NIPDAU	Level-2-260C-1 YEAR	0 to 70	UC3867DW	Samples
UC3867N	ACTIVE	PDIP	N	16	25	Green (RoHS & no Sb/Br)	CU NIPDAU	N / A for Pkg Type	0 to 70	UC3867N	Samples
UC3867NG4	ACTIVE	PDIP	N	16	25	Green (RoHS & no Sb/Br)	CU NIPDAU	N / A for Pkg Type	0 to 70	UC3867N	Samples
UC3868N	LIFEBUY	PDIP	N	16	25	Green (RoHS & no Sb/Br)	CU NIPDAU	N / A for Pkg Type	0 to 70	UC3868N	

(1) The marketing status values are defined as follows:

ACTIVE: Product device recommended for new designs.

LIFEBUY: TI has announced that the device will be discontinued, and a lifetime-buy period is in effect.

NRND: Not recommended for new designs. Device is in production to support existing customers, but TI does not recommend using this part in a new design.

PREVIEW: Device has been announced but is not in production. Samples may or may not be available.

OBsolete: TI has discontinued the production of the device.

(2) Eco Plan - The planned eco-friendly classification: Pb-Free (RoHS), Pb-Free (RoHS Exempt), or Green (RoHS & no Sb/Br) - please check <http://www.ti.com/productcontent> for the latest availability information and additional product content details.

TBD: The Pb-Free/Green conversion plan has not been defined.

Pb-Free (RoHS): TI's terms "Lead-Free" or "Pb-Free" mean semiconductor products that are compatible with the current RoHS requirements for all 6 substances, including the requirement that lead not exceed 0.1% by weight in homogeneous materials. Where designed to be soldered at high temperatures, TI Pb-Free products are suitable for use in specified lead-free processes.

Pb-Free (RoHS Exempt): This component has a RoHS exemption for either 1) lead-based flip-chip solder bumps used between the die and package, or 2) lead-based die adhesive used between the die and leadframe. The component is otherwise considered Pb-Free (RoHS compatible) as defined above.

Green (RoHS & no Sb/Br): TI defines "Green" to mean Pb-Free (RoHS compatible), and free of Bromine (Br) and Antimony (Sb) based flame retardants (Br or Sb do not exceed 0.1% by weight in homogeneous material)

(3) MSL, Peak Temp. - The Moisture Sensitivity Level rating according to the JEDEC industry standard classifications, and peak solder temperature.

(4) There may be additional marking, which relates to the logo, the lot trace code information, or the environmental category on the device.

(5) Multiple Device Markings will be inside parentheses. Only one Device Marking contained in parentheses and separated by a "~" will appear on a device. If a line is indented then it is a continuation of the previous line and the two combined represent the entire Device Marking for that device.

(6) Lead/Ball Finish - Orderable Devices may have multiple material finish options. Finish options are separated by a vertical ruled line. Lead/Ball Finish values may wrap to two lines if the finish value exceeds the maximum column width.

Important Information and Disclaimer:The information provided on this page represents TI's knowledge and belief as of the date that it is provided. TI bases its knowledge and belief on information provided by third parties, and makes no representation or warranty as to the accuracy of such information. Efforts are underway to better integrate information from third parties. TI has taken and continues to take reasonable steps to provide representative and accurate information but may not have conducted destructive testing or chemical analysis on incoming materials and chemicals. TI and TI suppliers consider certain information to be proprietary, and thus CAS numbers and other limited information may not be available for release.

In no event shall TI's liability arising out of such information exceed the total purchase price of the TI part(s) at issue in this document sold by TI to Customer on an annual basis.

OTHER QUALIFIED VERSIONS OF UC1861, UC1863, UC1863-SP, UC1864, UC1865, UC1867, UC3861, UC3863, UC3864, UC3865, UC3867 :

- Catalog: [UC3861](#), [UC3863](#), [UC1863](#), [UC3864](#), [UC3865](#), [UC3867](#)
- Military: [UC1861](#), [UC1863](#), [UC1864](#), [UC1865](#), [UC1867](#)
- Space: [UC1863-SP](#)

NOTE: Qualified Version Definitions:

- Catalog - TI's standard catalog product
- Military - QML certified for Military and Defense Applications
- Space - Radiation tolerant, ceramic packaging and qualified for use in Space-based application

TAPE AND REEL BOX DIMENSIONS



*All dimensions are nominal

Device	Package Type	Package Drawing	Pins	SPQ	Length (mm)	Width (mm)	Height (mm)
UC3867DWTR	SOIC	DW	16	2000	367.0	367.0	38.0

IMPORTANT NOTICE

Texas Instruments Incorporated and its subsidiaries (TI) reserve the right to make corrections, enhancements, improvements and other changes to its semiconductor products and services per JESD46, latest issue, and to discontinue any product or service per JESD48, latest issue. Buyers should obtain the latest relevant information before placing orders and should verify that such information is current and complete. All semiconductor products (also referred to herein as "components") are sold subject to TI's terms and conditions of sale supplied at the time of order acknowledgment.

TI warrants performance of its components to the specifications applicable at the time of sale, in accordance with the warranty in TI's terms and conditions of sale of semiconductor products. Testing and other quality control techniques are used to the extent TI deems necessary to support this warranty. Except where mandated by applicable law, testing of all parameters of each component is not necessarily performed.

TI assumes no liability for applications assistance or the design of Buyers' products. Buyers are responsible for their products and applications using TI components. To minimize the risks associated with Buyers' products and applications, Buyers should provide adequate design and operating safeguards.

TI does not warrant or represent that any license, either express or implied, is granted under any patent right, copyright, mask work right, or other intellectual property right relating to any combination, machine, or process in which TI components or services are used. Information published by TI regarding third-party products or services does not constitute a license to use such products or services or a warranty or endorsement thereof. Use of such information may require a license from a third party under the patents or other intellectual property of the third party, or a license from TI under the patents or other intellectual property of TI.

Reproduction of significant portions of TI information in TI data books or data sheets is permissible only if reproduction is without alteration and is accompanied by all associated warranties, conditions, limitations, and notices. TI is not responsible or liable for such altered documentation. Information of third parties may be subject to additional restrictions.

Resale of TI components or services with statements different from or beyond the parameters stated by TI for that component or service voids all express and any implied warranties for the associated TI component or service and is an unfair and deceptive business practice. TI is not responsible or liable for any such statements.

Buyer acknowledges and agrees that it is solely responsible for compliance with all legal, regulatory and safety-related requirements concerning its products, and any use of TI components in its applications, notwithstanding any applications-related information or support that may be provided by TI. Buyer represents and agrees that it has all the necessary expertise to create and implement safeguards which anticipate dangerous consequences of failures, monitor failures and their consequences, lessen the likelihood of failures that might cause harm and take appropriate remedial actions. Buyer will fully indemnify TI and its representatives against any damages arising out of the use of any TI components in safety-critical applications.

In some cases, TI components may be promoted specifically to facilitate safety-related applications. With such components, TI's goal is to help enable customers to design and create their own end-product solutions that meet applicable functional safety standards and requirements. Nonetheless, such components are subject to these terms.

No TI components are authorized for use in FDA Class III (or similar life-critical medical equipment) unless authorized officers of the parties have executed a special agreement specifically governing such use.

Only those TI components which TI has specifically designated as military grade or "enhanced plastic" are designed and intended for use in military/aerospace applications or environments. Buyer acknowledges and agrees that any military or aerospace use of TI components which have **not** been so designated is solely at the Buyer's risk, and that Buyer is solely responsible for compliance with all legal and regulatory requirements in connection with such use.

TI has specifically designated certain components as meeting ISO/TS16949 requirements, mainly for automotive use. In any case of use of non-designated products, TI will not be responsible for any failure to meet ISO/TS16949.

Products

Audio	www.ti.com/audio
Amplifiers	amplifier.ti.com
Data Converters	dataconverter.ti.com
DLP® Products	www.dlp.com
DSP	dsp.ti.com
Clocks and Timers	www.ti.com/clocks
Interface	interface.ti.com
Logic	logic.ti.com
Power Mgmt	power.ti.com
Microcontrollers	microcontroller.ti.com
RFID	www.ti-rfid.com
OMAP Applications Processors	www.ti.com/omap
Wireless Connectivity	www.ti.com/wirelessconnectivity

Applications

Automotive and Transportation	www.ti.com/automotive
Communications and Telecom	www.ti.com/communications
Computers and Peripherals	www.ti.com/computers
Consumer Electronics	www.ti.com/consumer-apps
Energy and Lighting	www.ti.com/energy
Industrial	www.ti.com/industrial
Medical	www.ti.com/medical
Security	www.ti.com/security
Space, Avionics and Defense	www.ti.com/space-avionics-defense
Video and Imaging	www.ti.com/video

TI E2E Community

e2e.ti.com