



Interconnect Solutions
Cannon, VEAM, BIW

Cannon APD Series ISO 15170 Connectors



Engineered for life

Cannon, VEAM, BIW

A Historical Achievement of Technology Leadership

Defining and Championing Innovation

Showcasing a portfolio of creativity, ITT's "Engineered For Life" execution embraces products which have become ubiquitous in a broad collection of markets including: Military/Aerospace, Civil Aircraft, Industrial Instrumentation, Medical, Oil & Gas, Energy, Transportation, Telecom/Handset, Computer, Consumer, and Automotive.

ITT's rich interconnect history embraces contributions to both technological breakthroughs and social movements. With one of the industry's broadest product offerings, ITT's interconnect products have supported:

- Every Free World space mission, bringing the universe to our doorstep.
- Motion picture, radio, and television equipment, serving laughter and entertainment to millions.
- Commercial and military communications systems, linking the voices of the world.
- Computerized tools, reshaping the information highway.
- Aircraft, rapid transit, and automobiles, mobilizing our expanding society.
- Oil and natural gas production, powering the world's economies.
- Agricultural equipment, attacking the roots of world hunger.

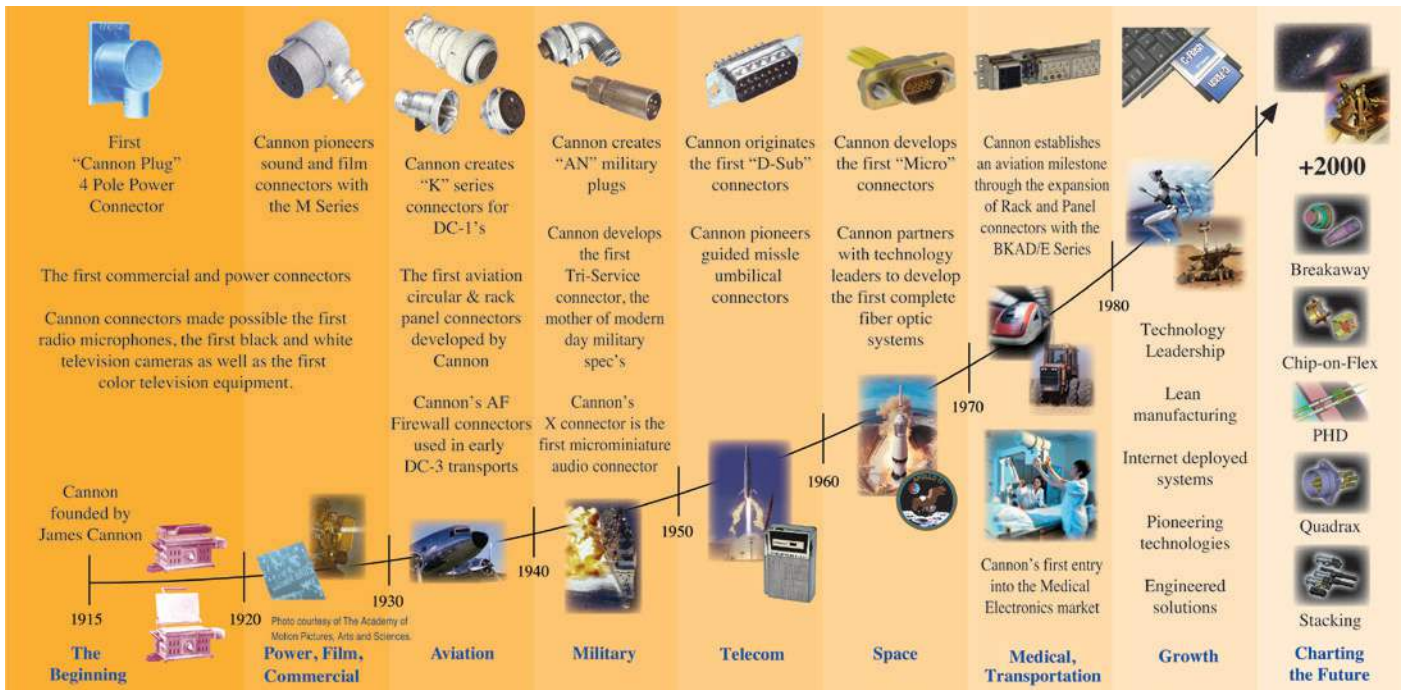

ITT Interconnect Solutions

ITT Interconnect Solutions is a division of the multi-national ITT Corporation, a \$9 billion dollar global enterprise representing the brands Cannon, VEAM, and BIW. Our connector portfolio remains the most extensive in the industry offering the most reliable and cost effective range of interconnect solutions. These innovations have enabled ITT to provide products and technologies to such markets as:

- Automotive
- Computer/Consumer
- Industrial/Instrumentation
- Military/Aerospace
- Oil Fields
- Telecom/Handset
- Transportation

When you specify a Cannon, VEAM or BIW connector, you can rely on a product designed, developed, and manufactured to the highest quality and reliability standards. This tradition of excellence is based on ITT's corporate culture of operating its businesses under the principles of Six Sigma. At ITT, Six Sigma is not just a quality philosophy but a complete corporate culture that drives the entire business. Our Value Based Management and Value Based Product Development systems are two cornerstones that allow for the development of both leadership and product engineering principles, ensuring the correct industry leading products are developed to the accepted market driven lead times. These principles have allowed ITT to become the market leader in all of our business portfolios.

Six Sigma Manufacturing

ITT operates manufacturing facilities in the United States, Germany, Italy, Mexico, China, Japan and the UK, all of which have particular product area strengths allowing ITT to offer a truly global footprint to our customers. Our facilities are world class and accommodate full vertical integration utilizing the latest manufacturing technologies including: automated and robotic machining centers, Super Market manufacturing cells, Kanban pull systems, and automated electrical, mechanical, and optical test and inspection equipment. The combination of our manufacturing strength and our advanced manufacturing facilities allows ITT to offer products

at market driven prices. Our capabilities, especially in robotics, computerized precision tooling, Kaizen Project Management, Six Sigma tools, and testing, give ITT the most optimized global manufacturing footprint in the interconnect industry.

The Custom Difference

As the industry leader in harsh environment interconnect applications, ITT's world class engineering teams will work directly with our customers to design and develop cost effective solutions for their applications. In many cases we may modify one of our standard designs to ensure a highly reliable solution where timing is critical. Yet, in those cases where a complete custom interconnect solution is required, ITT will work with our customer's Engineers to design an interconnect solution which will be cost effective yet highly reliable. As professional consultants, our Engineering teams will provide a thorough systems and mechanical analysis of any proposed solution. These analyses provide our customers with sophisticated electrical signal and mechanical characterizations to determine the best solution for their application.

RoHS Compliance Information

ITT has implemented a strict parts control plan for all ITT electronics plants worldwide that allows the Cannon, VEAM, and BIW connector product portfolios to meet the requirements of European Union Directive 2002/95/EC better known as the Reduction of Hazardous Substances initiative. As appropriate, specific Cannon, VEAM, and BIW products may be ordered with an R prefix number which insures our customers will receive RoHS compliant parts for their commercial electronics applications and equipment. Since most RoHS hazardous substances center around specific metal plating and lead solder coatings, ITT's products for RoHS compliance are available in the following plating finishes: black zinc electroless nickel, stainless steel, Anodize over aluminum and Gold plating. It should be noted that gold plating would be recommended as the replacement for tin-lead solder when ordering board mount connectors.



Interconnect Technologies & Solutions for the Transportation Industry

For over 90 years, ITT has been developing innovative solutions for harsh environment applications. We have a proven track record of demonstrating our expertise and commitment to the transportation industry, offering the broadest portfolio of interconnect products.

Off-Road / Heavy Vehicle

Our interconnect range include sealed circulars, plastic and metal shell bayonet coupling circulars, miniature metal shell circulars, PC board header connectors and sensor and direct device connectors. ITT is also a systems supplier, providing value-added module and harness assemblies.

***In addition to our APD ISO 15170 series,
we also offer these connectivity solutions:***



VEAM VBN

Completely intermateable with VEAM VG95234/CIR reverse bayonet connectors.



Cannon CA-Bayonet

Signal and power connectors with exceptional sealing against the ingress of fluids and will withstand the effects of high vibrations.



Cannon Trident

Versatile range of electrical connectors based on a standard contact design. Options include; industrial grade, harsh environment and shielded circulars.

Cannon Sure Seal

Sure Seal is a series of rugged, IP 67 proof connectors. The one piece molded body provides integrated sealing and excellent vibration resistance.



The ITT "Engineered Blocks" symbol and the composite ITT logo are registered trademarks of ITT Corporation. © 2011



APD is a versatile range of full plastic direct, in-line and bulkhead connectors. The products were originally designed for the transportation, off-road and special vehicle markets meeting all typical demands of applications in this field. In the meantime APD is also the connector of choice in other areas as e.g. military or industrial applications that require harsh environment solutions while needing a product that is both, small in size and light in weight.







The APD series covers a wide range of 1 and 2-way power solutions up to 51-way interface connectors, special sensor or PCB type versions and a flexible platform for your customized solutions.

Based on the original DIN72585 standard – now replaced by ISO 15170 – this connector is an ideal solution whenever harsh environment requirements like resistance to engine, transmission or brake fluids, high sealing grades up to IP69K or vibration requirements have to be met. Please be aware that all mentioned connectors are not designed to be disconnected under load.

APD 1-2-way	7-24
APD 4-7-way	25-41
APD Sensor Connectors	42-43
APD 19-way	44-54
APD 37 & 51-way	55-72
APD PCB Versions	73
Conversion Charts	74
Part Number Index	75-76

APD / ISO 15170						
Series	1-way	1-way	2-way	2-way	4-way	4-way
Type	Plug	Receptacle Flange / Jam Nut / Snap-In	Plug	Receptacle Flange / Jam Nut / Snap-In	Plug	Receptacle Flange / Jam Nut
Contacts Materials	Copper alloy silver plated	Copper alloy silver plated	Copper alloy silver plated	Copper alloy silver plated	Copper alloy tin, silver, gold plated	Copper alloy tin, silver, gold plated
Contact style	Machined	Machined	Machined	Machined	Stamped & Formed	Stamped & Formed
Page Number	8	9-11	19	19-21	26	27-28

APD / ISO 15170						
Series	6/7-way	6/7-way	Sensor style 1	Sensor style 2	19-way	19-way
Type	Plug	Receptacle Flange / Jam Nut	Receptacle	Receptacle	Plug	Receptacle Flange / Jam Nut/ Wire-to-wire
Contacts Materials	Copper alloy silver plated	Copper alloy silver plated	Copper alloy silver plated	Copper alloy silver plated	Copper alloy tin, silver, gold plated	Copper alloy tin, silver, gold plated
Contact style	Stamped & Formed Machined	Stamped & Formed Machined	Machined	Machined	Stamped & Formed	Stamped & Formed
Page Number	36	37-38	42	43	45	46-48

APD / ISO 15170						
Series	37-way	37-way	51-way	51-way	51-way	PCB
Type	Plug	Receptacle Flange	Plug	Receptacle Jam Nut	Receptacle Snap In	Receptacle
Contacts Materials	Copper alloy silver plated	Copper alloy silver plated	Copper alloy silver plated	Copper alloy silver plated	Copper alloy tin, silver, gold plated	Copper alloy tin, silver, gold plated
Contact style	Stamped & Formed Machined	Stamped & Formed Machined	Stamped & Formed Machined	Stamped & Formed Machined	Stamped & Formed Machined	Machined
Page Number	56	57	63	65	64	73



The APD 1 / 2-way connectors are derived from ISO 15170 and adapted to applications requiring high power. These versions cover wire ranges from 16 mm² up to 50 mm² power and a power consumption up to 245A. The combination of small size and high power make them an ideal solution for many applications.

Applications for the 1 / 2-way connector include:

- Tail lifts
- On Board Kitchen
- Power Supply for Antennas and Base Stations

Power Distribution in:

- Trucks
- Tractors

Electrical Data

Operating Voltage	48 VDC*
Operating Current	see derating curve
Contact Resistance	0,4 mΩ max.
Voltage Proof	1000 VAC, 60 seconds
Insulation Resistance	10 MΩ min.

Mechanical Data

Durability	50 Mating Cycles
Coupling Torque	2 Nm max.
Static Load, free connector	350 N (ISO 15170-2, Sec. 4.6)

Environmental Data (acc. ISO 15170)

Temperature Range	-40 °C up to 125 °C (ISO 15170-2, Sec. 6.4)
Humidity Range	up to 95 % r.h. (ISO 15170-2, Sec. 6.4)
Sealing	IP 67 (DIN EN 60529)*
Salt Spray	96 h, 35 °C (ISO 15170-2, Sec. 6.2)
Industrial Climate	SO ₂ , 0,67 % (ISO 15170-2, Sec. 6.3)
Fluid Compatibility	Brakefluid, ATF, fuel, .. (ISO 15170-2, Sec. 6.6)*
Vibration Resistance	Sine, 100 m/s ² , 3 axis, 24h, RT (EN 60512)*

Materials List

Housing Parts	PBT GF
Sealing Parts	HNBR (alternative FKM)
Coupling Nut	PA 66 GF
Contacts	Copper Alloy, Ag plated

* Further information available upon request

Dimensions shown in mm
 Specifications and dimensions subject to change

High Power Plug, 1-way

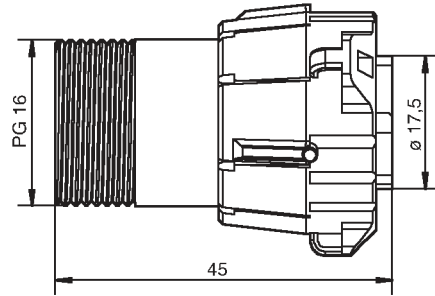
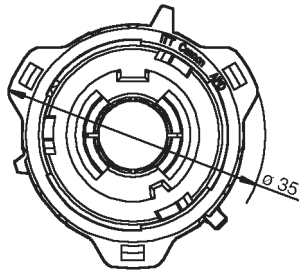

Order No.	Designation	Code	Color
121583-0012	APD-5BSH	5	blue (RAL 5012)
121583-0013	APD-6BSH	6	red (RAL 2002)
121583-0042	APD-7BSH	7	black (RAL 9005)

Packaging unit 100 pcs.

Socket crimp contacts see pages 12 and 13.

Accessories, see pages 15 and 16.

Note: Always use hex nut and cable seal.

Coding, 1-way layouts

View on Mating Face

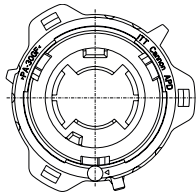

Code 5
blue

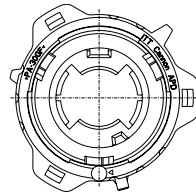

Code 6
red

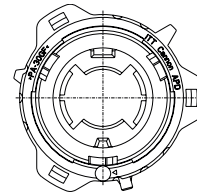

Code 7
black

Note: the connectors offer both mechanical keying and visual coding by different colors.

High Power Flange Receptacle, 1-way

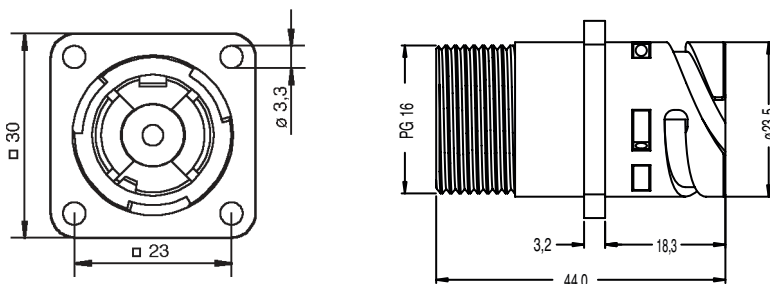

Order No.	Designation	Code	Color
121583-0014	APD-5APH	5	blue (RAL 5012)
121583-0015	APD-6APH	6	red (RAL 2002)
121583-0043	APD-7APH	7	black (RAL 9005)

Packaging unit 100 pcs.

Pin crimp contacts see pages 12, 13 and 14.

Accessories, see pages 15 and 16.

Note: Always use hex nut and cable seal.

Coding, 1-way layouts

View on Mating Face

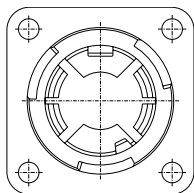

Code 5
blue

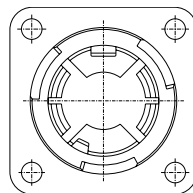

Code 6
red

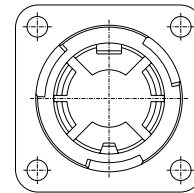

Code 7
black

Note: the connectors offer both mechanical keying and visual coding by different colors.

Panel Cut Out

Flange for all Flange Receptacles

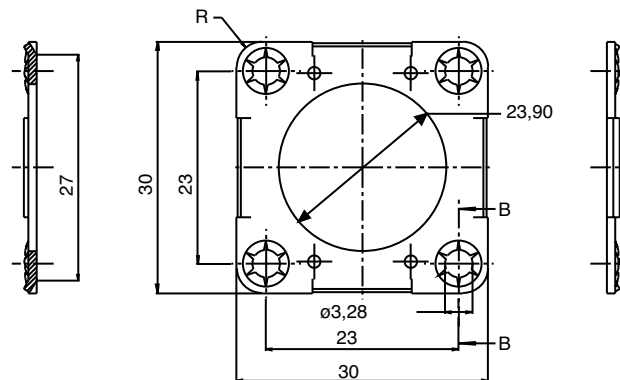
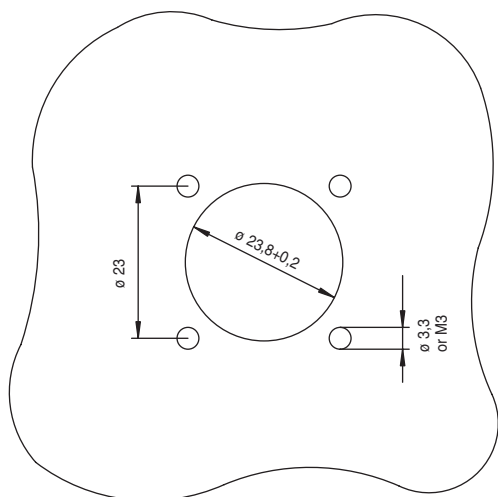

Order Number: 066-8516-005

Metal mounting flange for wall mounting of flange receptacles.

Dimensions shown in mm
Specifications and dimensions subject to change

High Power Jam Nut Receptacle, 1-way

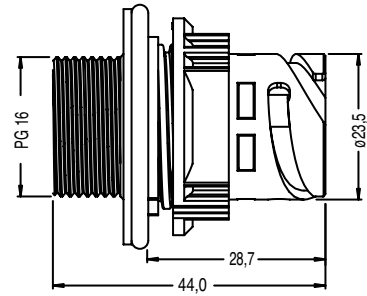
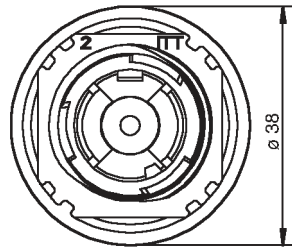

Order No.	Designation	Code	Color
121583-0016	APD-5CPH	5	blue (RAL 5012)
121583-0017	APD-6CPH	6	red (RAL 2002)
121583-0217	APD-7CPH	7	black (RAL 9005)

Packaging unit 100 pcs.

Pin crimp contacts see pages 12, 13 and 14.

Accessories, see pages 15 and 16.

Note: Includes jam nut for wall thickness 1...4 mm. Always use hex nut and cable seal.

Coding, 1-way layouts

View on Mating Face

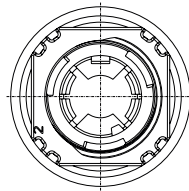

Code 5
blue

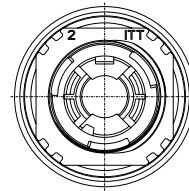

Code 6
red

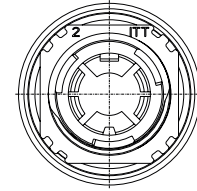

Code 7
black

Note: the connectors offer both mechanical keying and visual coding by different colors.

Panel Cut Out

Flange for all Flange Receptacles

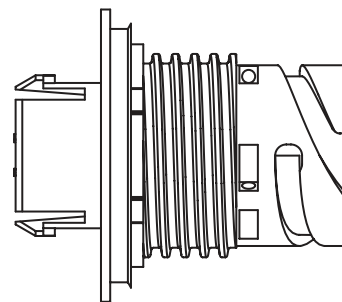
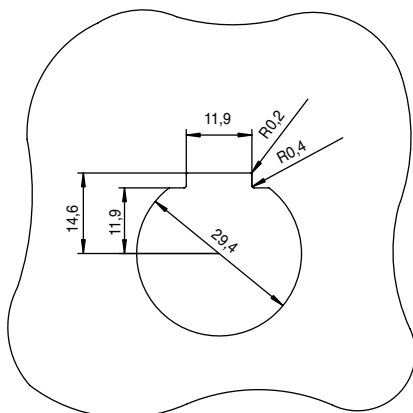

Housing



O-ring

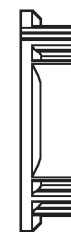

Jam Nut

Wall thickness: Standard Jam Nut: min. 1,0 / max. 4,0 mm Special Jam Nut: min. 2,0 / max. 5,0 mm

Jam Nut, special

Designation	Order No.
for special wall thickness 2,0 - 5,0 mm	217-8516-001



Dimensions shown in mm
Specifications and dimensions subject to change

High Power Snap-In Receptacle, 1-way

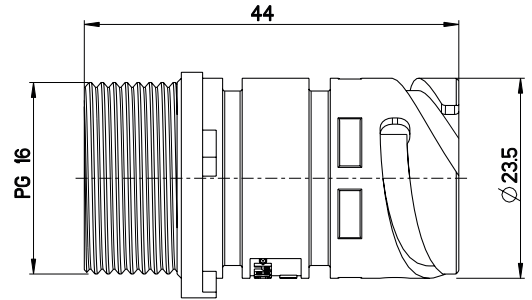
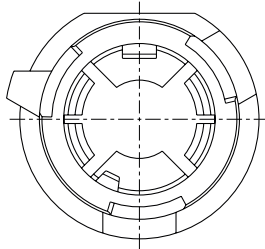

Order No.	Designation	Code	Color
249-8619-005	APD-7SPH	7	black (RAL 9005)
249-8619-006	APD-6SPH	6	red (RAL 2002)
consult factory	APD-5SPH	5	blue (RAL 5012)

Packaging unit 100 pcs.

Pin crimp contacts see pages 12, 13 and 14.

Accessories, see pages 15 and 16.

Note: Always use hex nut and cable seal.

Coding, 1-way layouts

View on Mating Face

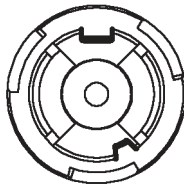

Code 5
blue

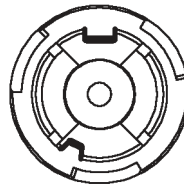

Code 6
red

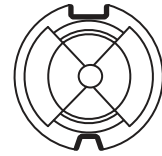

Code 7
black

Note: the connectors offer both mechanical keying and visual coding by different colors.

Panel Cut Out

3D data for design of snap-in cut out available on request. Please consult factory.

Machined Socket Crimp-Contacts, High Performance Copper, Silver plated

Order No.	AWG	Contact size	d5+0,15
031-8521-030 (16,00 mm ²)		0	6,2
031-8521-010 (25,00 mm ²)	4	0	7,6
031-8521-020 (35,00 mm ²)	2	0	9,1
031-8646-015 (50,00 mm ²)	with bunch	0	10,2

Packaging unit 100 pcs.

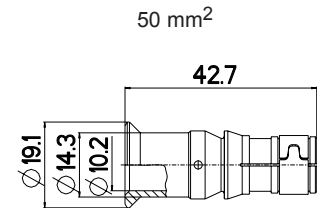
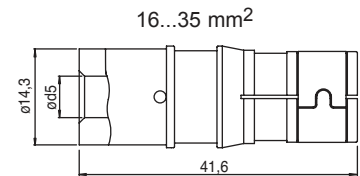

Machined Pin Crimp Contacts, High Performance Copper, Silver plated

Order No.	AWG	contact size	d6+0,15
030-8614-030 (16,00 mm ²)		0	6,2
030-8614-010 (25,00 mm ²)	4	0	7,6
030-8614-020 (35,00 mm ²)	2	0	9,1
030-8581-029 (50,00 mm ²)	with bunch	0	10,2

Packaging unit 100 pcs.

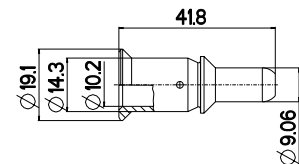
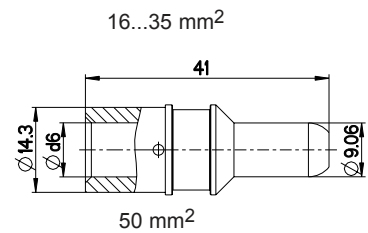

Derating Curve, High Performance Copper Contact

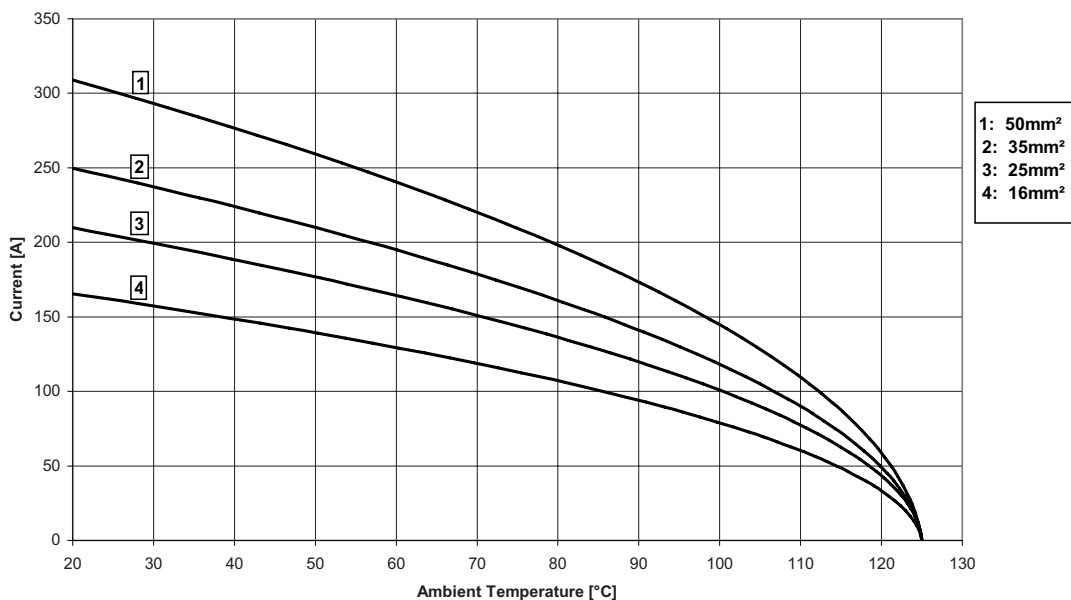

Machined Socket Crimp-Contacts, Standard Brass, Silver plated

Order No.	AWG	Contact size	d5+0,15
031-8531-010 (16,00 mm ²)		0	6,2
031-8531-011 (25,00 mm ²)	4	0	7,6
031-8531-012 (35,00 mm ²)	2	0	9,1
031-8531-013 (50,00 mm ²)	with bunch	0	10,2

Packaging unit 100 pcs.

*Available by Request

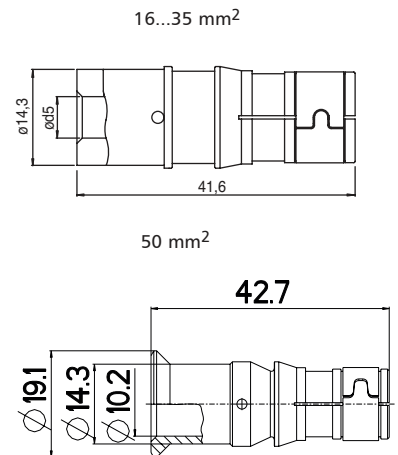

Machined Pin Crimp Contacts, Standard Brass, Silver plated

Order No.	AWG	contact size	d6+0,15
030-8581-030 (16,00 mm ²)		0	6,2
030-8581-031 (25,00 mm ²)	4	0	7,6
030-8581-032 (35,00 mm ²)	2	0	9,1
030-8581-033 (50,00 mm ²)	with bunch	0	10,2

Packaging unit 100 pcs.

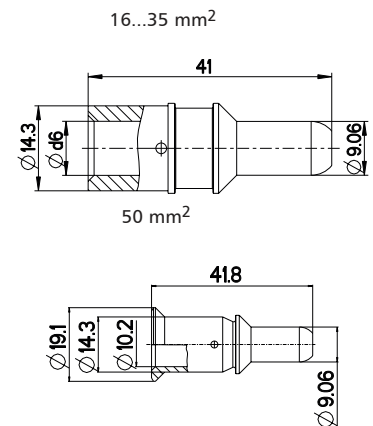

Derating Curve, Standard Brass Contact

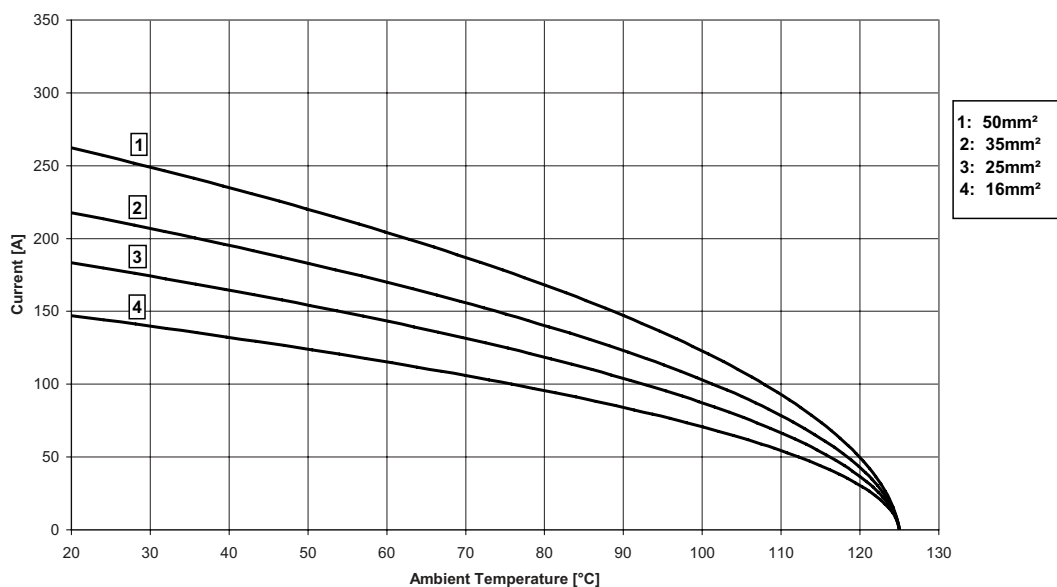

Dimensions shown in mm
 Specifications and dimensions subject to change



A new finger protected pin contact has been implemented for the APD High Power 1-way connector series.

Applications for the 1-way connector include:

- Tail lifts
- On Board Navigation
- Power Supply for Antennas and Base Stations

Power Distribution in:

- Trucks
- Tractors
- Hybrid and Electric Vehicles

Machined Pin Crimp Contacts, High Performance Copper, Silver plated, Finger Protected

Order No.	AWG	Contact size	d5+0,15
120110-0229 (16,00 mm ²)		0	6,2
120110-0220 (25,00 mm ²)	4	0	7,6
120110-0221 (35,00 mm ²)	2	0	9,1
120110-0222 (50,00 mm ²)	with bunch	0	10,2

Packaging unit 100 pcs.

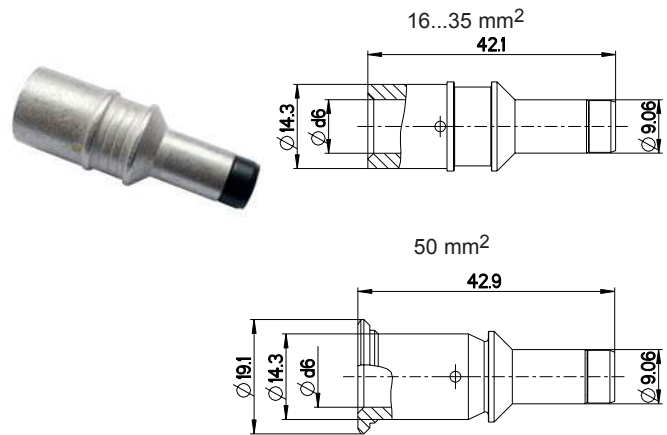

Derating Curve, High Performance Copper Contact, Finger Protected

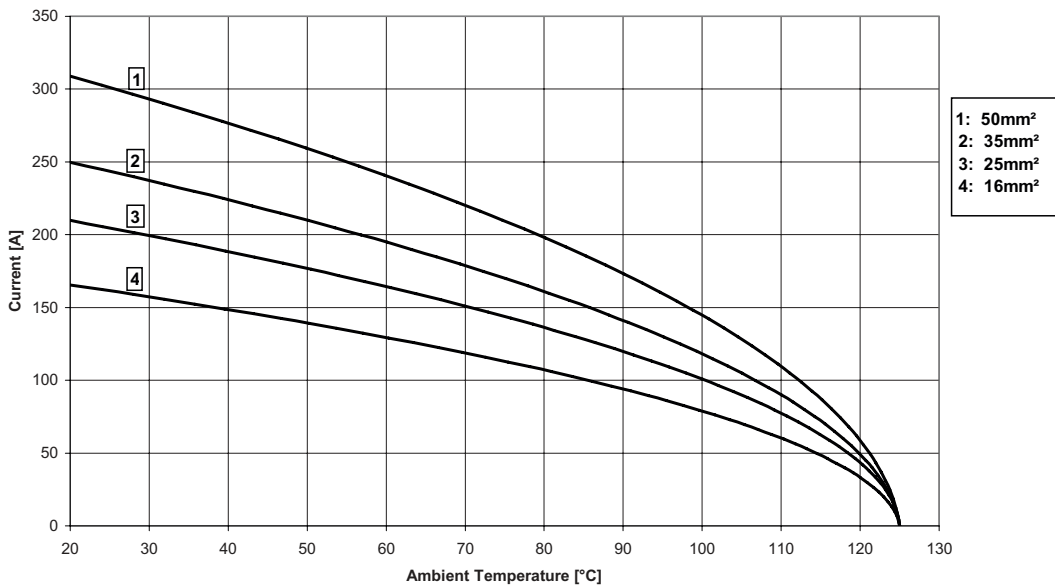

Sealing Cap for Receptacle

Designation Order No.
 APD-DP 121583-0021

Packaging unit 100 pcs.

APD-DP with rope, end link and eyelet
 X = Total rope length upon request

Order number 120110-0026* X~9cm

* for other lengths please consult the factory

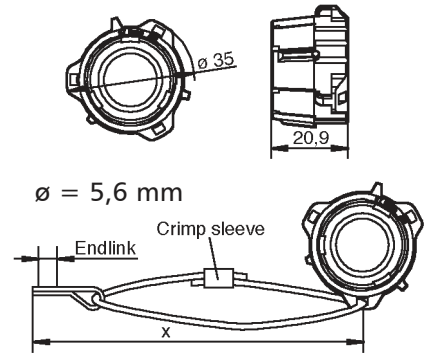

Cable Seal for Cable (in acc. to DIN 670722 FLY/ DIN 72551 FLRY) High Power 1-way

Order No.	Insulation \varnothing	\varnothing A mm
351-8697-005	5,8 - 7,4	5,4
351-8697-014	7,4 - 8,4	6,5
351-8697-009	8,4 - 10,0	8,0
351-8697-001	10,4 - 12,0	10,0
351-8697-002	12,3 - 13,9	11,9
351-8697-003	14,2 - 15,8	13,8

Packaging unit 100 pcs.

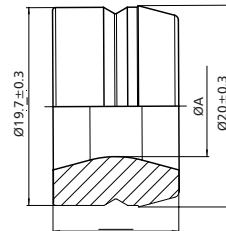

Hexagonal Nut

High Power 1-way

Order No. 217-8516-010

Packaging unit 100 pcs.

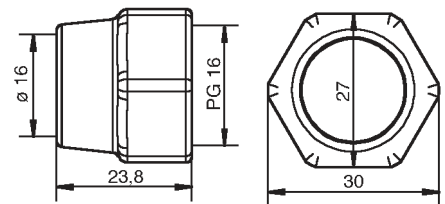

Flange Gasket

For Flange Receptacle, High Power 1-way

Order No.
 075-8503-000 (-55/125°C)
 075-8503-004 (-30/200°C)

Packaging unit 100 pcs.
 Nominal Width: 17

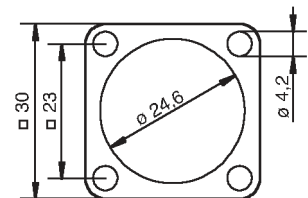

Adaptor for Flex Tube

For 1-way Plug and Receptacle

Order No. 980-8672-010 (\varnothing 17 mm)

Packaging unit 100 pcs.



90° Endbell

For 1-way Plug and Receptacle up to 25 mm² wire

Order No.: 980-8672-004

Packaging unit 100 pcs.



\varnothing max. = 17,4 mm
 thread = PG 16

Dimensions shown in mm
 Specifications and dimensions subject to change

Dust Cap for Plug

Order No. 025-8636-005

Packaging unit 100 pcs.

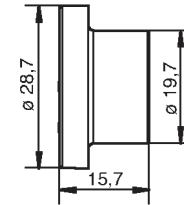

Dust Cap for Receptacle

Order No. 025-0480-000

Packaging unit 100 pcs.

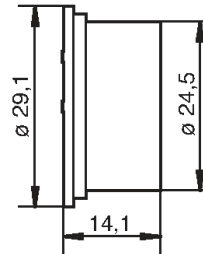

Blind Socket for 1 / 2 / 4 / 6 / 7-way

Order No. 120110-0217

Packaging unit 100 pcs.

Note: All cavities closed, mates with 1-7-way APD versions.



Tooling for 1-way High Power Connectors

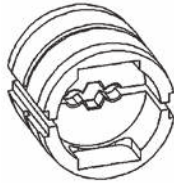

Contact / Socket	Crimp-Dies
031-8561-000 (50,00 mm ₂)	121586-5229
031-8521-020 (35,00 mm ₂ / AWG 2)	121586-5229
031-8521-010 (25,00 mm ₂ / AWG 4)	121586-5229
031-8521-030 (16,00 mm ₂)	121586-5229
Contact / Pin	Crimp-Dies
030-8592-000 (50,00 mm ₂)	121586-5229
030-8614-020 (35,00 mm ₂ / AWG 2)	121586-5229
030-8614-010 (25,00 mm ₂ / AWG 4)	121586-5229
030-8614-030 (16,00 mm ₂)	121586-5229
Optional locator	121586-5232

Assembly Tools Jam Nut Receptacle

Square box spanner for torque moment wrench to fix the jam nut.



Designation	Order No.
SS627G	317-8649-034

Assembly Tools (Hexagonal Nut)

To fix the hexagonal fixing nut 217-8516-010.

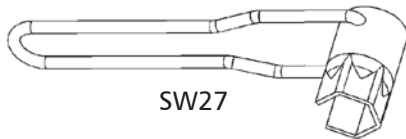

Order No.	980-8672-005
Torque: 2.5 ± 0.5Nm	

Assembly and Torque Wrench Adapter

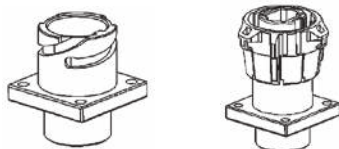

Designation	Order No.
MA-APD-1/ 2-P	248-8653-063
MA-APD-1/ 2-R	249-8619-010
1/4" adaption	

Contract Extraction Tool

Housing can not be reused.

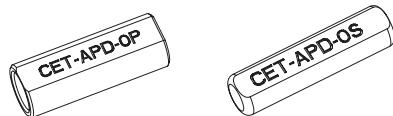

Designation	Order No.
CET-APD-#OP	121586-5192
CET-APD-#OS	121586-5193

Crimp Tool

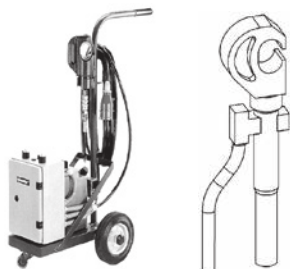

Crimp Tool	Designation	Order No.
Hydraulic, hand operated:	HPW400U-ITT	121586-5257
Electro-hydraulic, 230 V AC operated	HP400EL-ITT	121586-5253

For detailed assembly instruction please see CAS 25023.

Dimensions shown in mm
Specifications and dimensions subject to change

Electrical Data

Operating Voltage	48 VDC*
Operating Current	see derating curve
Contact Resistance	2 mΩ max.
Voltage Proof	1000 VAC, 60 seconds
Insulation Resistance	10 MΩ min.

Mechanical Data

Durability	50 Mating Cycles
Coupling Torque	2 Nm max.
Static Load, free connector	350 N (ISO 15170-2, Sec. 4.6)

Environmental Data (acc. ISO 15170)

Temperature Range	-40 °C up to 125 °C (ISO 15170-2, Sec. 6.4)
Humidity Range	up to 95 % r.h. (ISO 15170-2, Sec. 6.4)
Sealing	IP 67 (DIN EN 60529)*
Salt Spray	96 h, 35 °C (ISO 15170-2, Sec. 6.2)
Industrial Climate	SO ₂ , 0,67 % (ISO 15170-2, Sec. 6.3)
Fluid Compatibility	Brakefluid, ATF, fuel, .. (ISO 15170-2, Sec. 6.6)*

Materials List

Housing Parts	PBT GF
Sealing Parts	HNBR (alternative FKM)
Coupling Nut	PA 66 GF
Contacts	Copper Alloy, Ag plated

Derating Curve

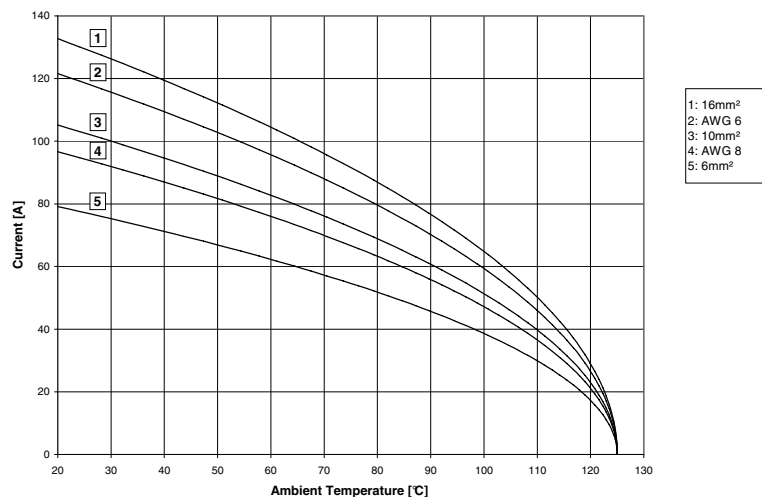

Further information available upon request.

High Power Plug, 2-way

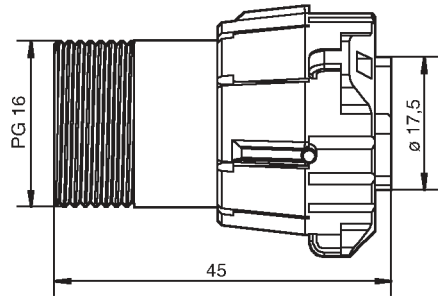
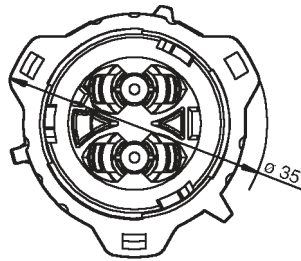

Order No.	Designation	Code	Color
121583-0083	APD-1BSH8-2-12	1	grey (RAL 7036)
121583-0025	APD-1BSH8-2	1	black (RAL 9005)
121583-0084	APD-1BSH8-2-14	1	blue (RAL 5012)

Packaging unit 100 pcs.
 Socket Crimp contacts see page 22.
 Accessories, see pages 22 and 23.
 Note: Always use hex nut and cable seal.

High Power Flange Receptacle, 2-way

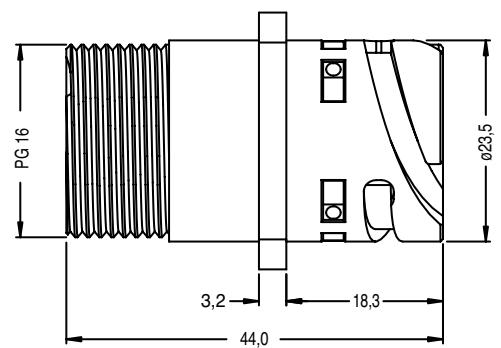
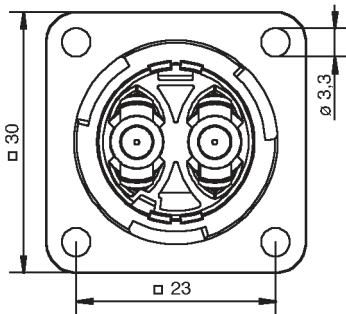

Order No.	Designation	Code	Color
121583-0026	APD-1APH8-2	1	black (RAL 9005)

Packaging unit 100 pcs.
 Pin crimp contacts see page 22.
 Accessories, see pages 22 and 23.
 Note: Always include hex nut and cable seal.

Panel Cut Out

Flange for all Flange Receptacles

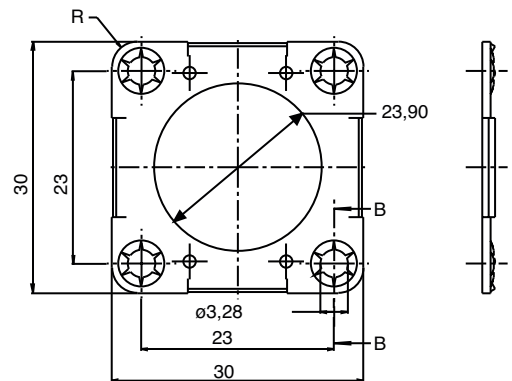
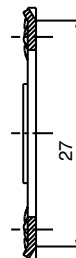
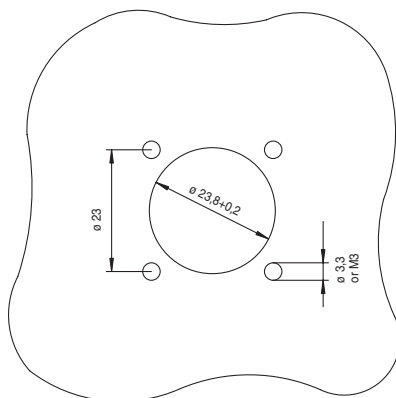

Order Number: 066-8516-005

Note: Metal mounting flange for wall mounting of flange receptacles.

Dimensions shown in mm
 Specifications and dimensions subject to change



High Power Jam Nut Receptacle, 2-way

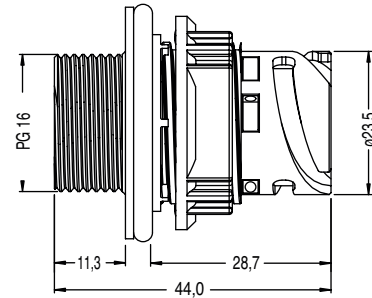
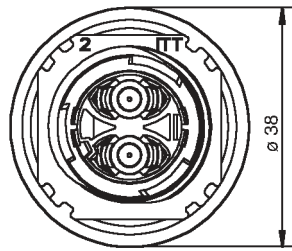

Order No.	Designation	Code	Color
121583-0085	APD-1CPH8-2-12	1	grey (RAL 7036)
121583-0027	APD-1CPH8-2	1	black (RAL 9005)
121583-0086	APD-1CPH8-2-14	1	blue (RAL 5012)

Packaging unit 100 pcs.

Pin crimp contacts see page 22.
Accessories, see pages 22 and 23.

Note: Includes jam nut for wall thickness 1..4 mm. Always use hex nut and cable seal.

Panel Cut Out Flange for all Flange Receptacles

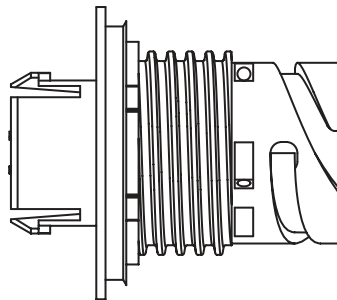
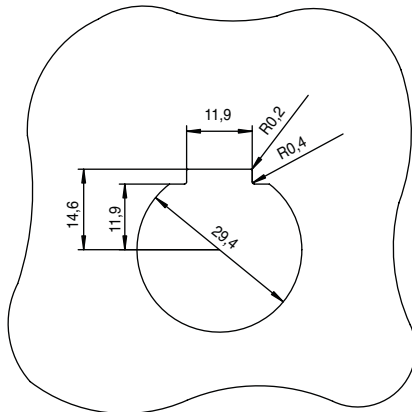

Housing



O-ring

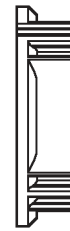

Jam Nut

Wall Thickness:

Standard Jam Nut: min. 1,0 / max. 4,0 mm
Special Jam Nut: min. 2,0 / max. 5,0 mm

Jam Nut, special

Designation	Order No.
for special wall thickness 2,0 - 5,0 mm	217-8516-001



High Power Snap-In Receptacle, 2-way

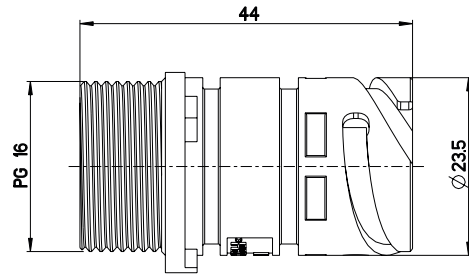
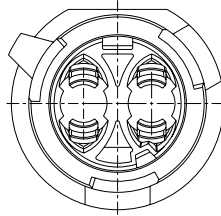

Order No.	Designation	Code	Color
249-8619-007	APD-1SPH8-2	1	black (RAL 9005)

Packaging unit 100 pcs.

Pin crimp contacts see page 22.

Accessories, see pages 22 and 23.

Note: Always use hex nut and cable seal.

Panel Cut Out

3D data for design of snap-in cut out available on request. Please consult factory.

Machined Pin Crimp Contacts, Standard Silver Plated

Order No.	d6	d8	L1
430-8645-000 (6,00 mm ²) *	3,4	6,8	33,4
430-8645-009 (10,00 mm ²)	4,3	6,8	30,9
430-8645-003 (AWG 8)	3,8	6,8	30,9
430-8645-002 (AWG 6)	5,3	6,8	30,9
430-8645-007 (16,00 mm ²)	5,5	7,5	30,9

Packaging unit 100 pcs.

* use individual wire seal or grommet

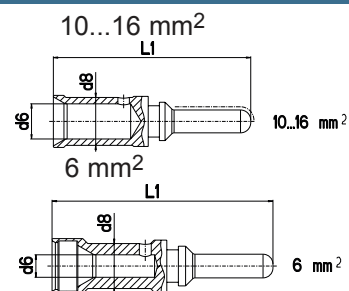

Machined Socket Crimp Contacts, Standard Silver Plated

Order No.	d5	d7	L2
031-8646-010 (6,00 mm ²) *	3,4	6,8	33,4
031-8646-011 (10,00 mm ²)	4,3	6,8	30,9
031-8646-002 (AWG 8)	3,8	6,8	30,9
031-8646-003 (AWG 6)	5,3	6,8	30,9
031-8646-001 (16,00 mm ²)	5,5	7,5	30,9

Packaging unit 100 pcs.

* use individual wire seal or grommet

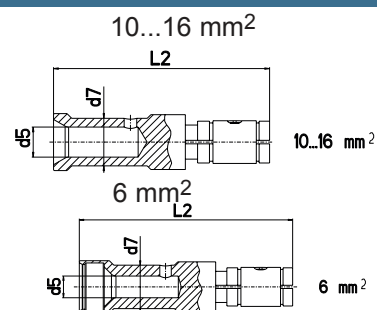

Individual Wire Seals

For High Power 2-way 6 mm² only

Designation	Order No.:
16GN5824	121668-0035

wire insulation ø 4,3 - 4,8 mm / green

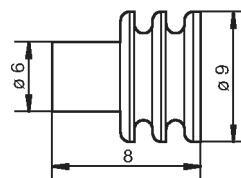

Cable Sealing Set

For High Power 2-way

Set consists of:
 Hexagonal Nut (1)
 Compression Support Plate for Cable Seal (2)
 Cable Seal for Cable (3)

Order No.	Wire Insulation Ø	Ø A
121583-1000	4,2 - 5,8	3,8
121583-1001	5,7 - 7,3	5,3
121583-1002	7,4 - 8,3	7,3
121583-1003	6,8 - 8,3	6,5

Packaging unit 100 pcs.

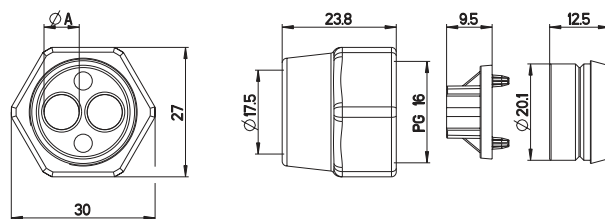
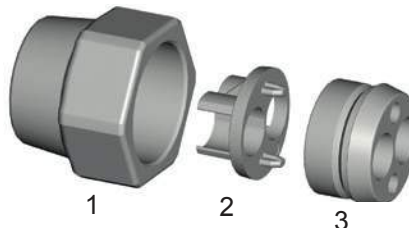

Flange Gasket

For Flange Receptacle, High Power 2-way

Order No.
075-8503-000 (-55/125°C)
075-8503-004 (-30/200°C)

Packaging unit 100 pcs.

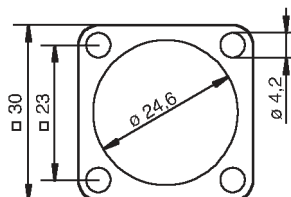

Dimensions shown in mm
 Specifications and dimensions subject to change

Sealing Cap for Receptacle

Designation Order No.
 APD-DP 121583-0021

Packaging unit 100 pcs.

APD-DP with rope, end link and eyelet
 X = Total rope length upon request

Order number 120110-0026* X~9cm

* for other lengths please consult the factory

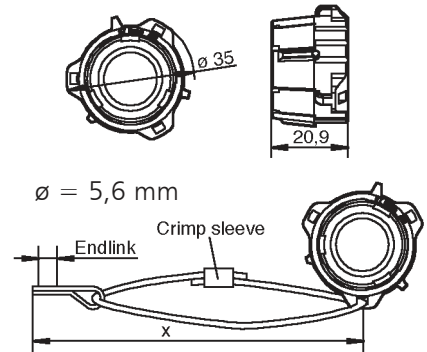

Adaptor for Flex Tube

For 2-way Plug and Receptacle

Order No. 980-8672-010 (ø 17 mm)

Packaging unit 100 pcs.
 Nominal Width: 17



90° Endbell

For 2-way Plug and Receptacle

Order No.: 980-8672-004

Packaging unit 100 pcs.



ø max. = 17,4 mm
 thread = PG 16

Dust Cap for Plug

Order No. 025-8636-005

Packaging unit 100 pcs.

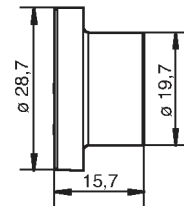

Dust Cap for Receptacle

Order No. 025-0480-000

Packaging unit 100 pcs.

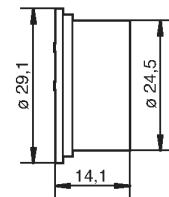

Blind Socket for 1 / 2 / 4 / 6 / 7-way

Order No. 120110-0217

Packaging unit 100 pcs.

Note: All cavities closed, mates with 1-7-way APD versions.



Dimensions shown in mm
 Specifications and dimensions subject to change

www.ittcannon.com



Crimp Die Tooling for 2-way High Power Connectors

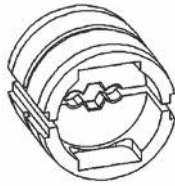

Contact / Socket	Designation	Order No.
031-8646-010 (6,00 mm ₂) with individual wire seal	CT120090-165	120090-0165
031-8646-011 (10,00 mm ₂)	CT120090-165	120090-0165
031-8646-002 (AWG 8)	CT120090-165	120090-0165
031-8646-003 (AWG 6)	CT120090-165	120090-0165
031-8646-001 (16,0 mm ₂)	CT120090-171	120090-0171

Contact / Socket	Designation	Order No.
430-8645-000 (6,00 mm ₂) with individual wire seal	CT120090-165	120090-0165
430-8645-009 (10,00 mm ₂)	CT120090-165	120090-0165
430-8645-003 (AWG 8)	CT120090-165	120090-0165
430-8645-002 (AWG 6)	CT120090-165	120090-0165
430-8645-007 (16,0 mm ₂)	CT120090-171	120090-0171

Assembly Tools Jam Nut Receptacle

Square box spanner for torque wrench to tighten the jam nut.

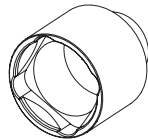

SW30

Order No.	317-8649-034
-----------	--------------

Assembly Tools Hexagonal Nut

To tighten the hexagonal fixing nut 217-8516-010.

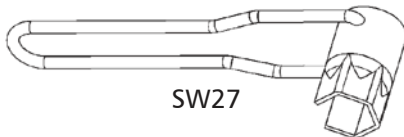

SW27

Designation	Order No.
SS627G	980-8672-005

Torque 2,5 +/- 0,5 Nm

Assembly and Torque Wrench Adapter

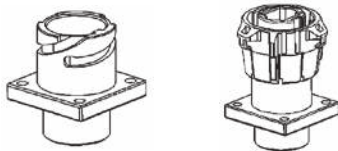

Designation	Order No.
MA-APD-1/2-P	248-8653-063
MA-APD-1/2-R	249-8619-010

1/4" adaption

Contract Extraction Tool

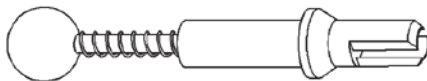

Designation	Order No.
CET- APD-2	121586-5149

for pin and socket contacts

Crimp Tool

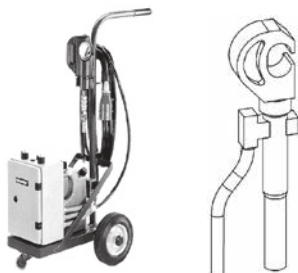

Crimp Tool	Designation	Order No.
Hydraulic, hand operated:	HK120-25	121586-5077
Electro-hydraulic, 230 V AC operated	HK12-EL	121586-5075
Hand Crimp Tool 6 / 10 / 16 mm ₂		121586-5244



Dimensions shown in mm
Specifications and dimensions subject to change

APD 4-way connectors are the original DIN72585 (now ISO 15170) versions using a 2,5 mm contact system.

Designed for automotive applications they also meet the requirements of transportation, off-road and special vehicle markets.

Applications for the 4- and 7-way connector include:

- Sensors
- Traction / Skid Control
- Brake Control
- Magnetic Switch Control Systems
- Lightening systems on Trucks and Trailers



Electrical Data

Operating Voltage	48 VDC*
Operating Current	see derating curve
Contact Resistance	5 mΩ max.
Voltage Proof	1000 VAC, 60 seconds
Insulation Resistance	10 MΩ min.

Mechanical Data

Durability	50 Mating Cycles
Coupling Torque	1,2 Nm max.
Static Load, mated Connector	250 N axial, 150 N lat. (ISO 15170-2, Sec. 4.5)
Static Load, free connector	350 N (ISO 15170-2, Sec. 4.6)

Environmental Data (acc. ISO 15170)

Temperature Range	-40 °C up to 125 °C (ISO 15170-2, Sec. 6.4)
Humidity Range	up to 95 % r.h. (ISO 15170-2, Sec. 6.4)
Sealing	IP 67 and IP 69k (DIN EN 60529)*
Salt Spray	96 h, 35 °C (ISO 15170-2, Sec. 6.2)
Industrial Climate	SO ₂ , 0,67 % (ISO 15170-2, Sec. 6.3)
Fluid Compatibility	Brakefluid, ATF, fuel, .. (ISO 15170-2, Sec. 6.6)*
Vibration Resistance	Sine, 300m/s ² , 3 x 100h, RT and 120°C (ISO 15170-2)*

Materials List

Housing Parts	PBT GF
Sealing Parts	HNBR (alternative FKM)
Coupling Nut	PA 66 GF
Contacts	Copper Alloy, Ag plated

* Further information available upon request

Dimensions shown in mm
Specifications and dimensions subject to change

Derating Curve

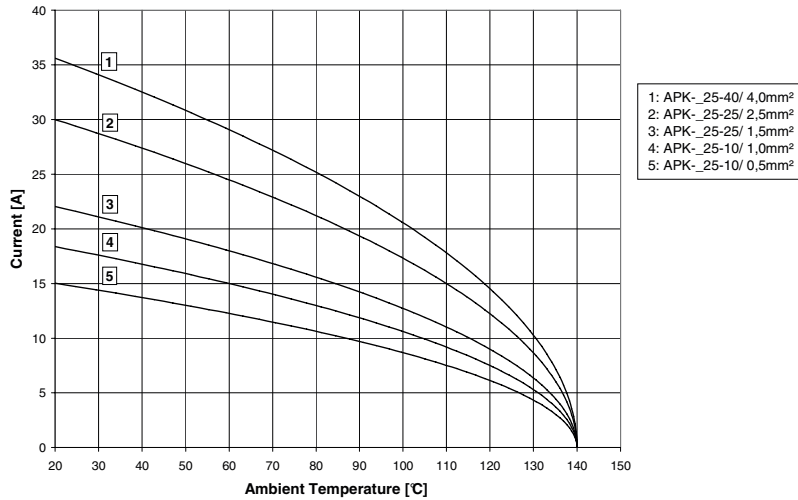

Plug, 4-way

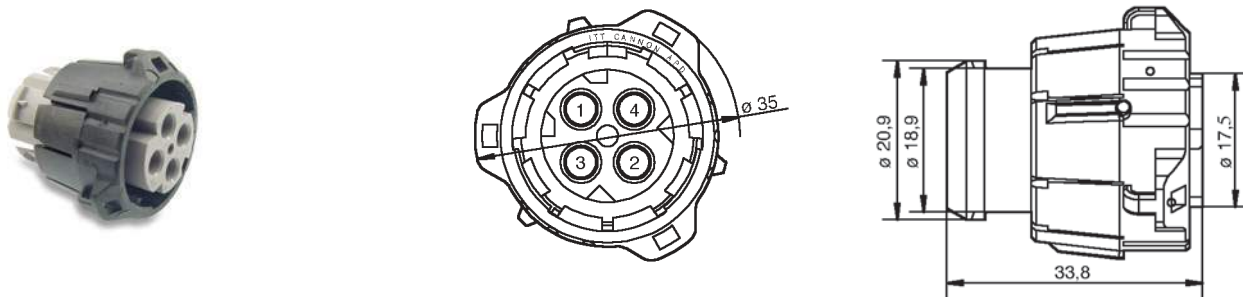

Order No.	Designation	Code	Color
121583-0000	APD-1BS-K2	1	black (RAL 9005)
121583-0001	APD-2BS-K2	2	grey (RAL 7036)
121583-0002	APD-3BS-K2	3	green (RAL 6029)
121583-0003	APD-4BS-K2	4	blue (RAL 5012)

Packaging unit 100 pcs.

Socket crimp contacts see page 32.
Accessories, see pages 32 and 33.

Coding, 4-way layouts

View on Mating Face



Code 1
black

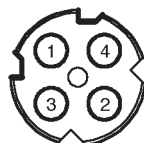

Code 2
grey

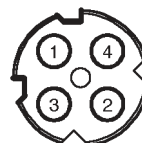

Code 3
green

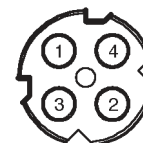

Code 4
blue

Note: The connectors offer both mechanical keying and visual coding by different colors.

Flange Receptacle, 4-way

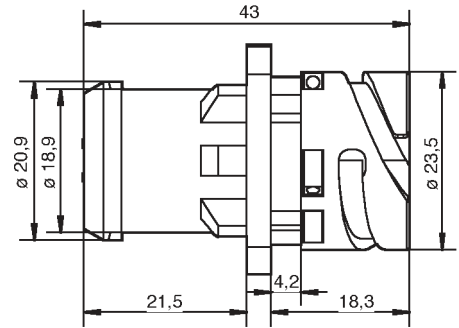
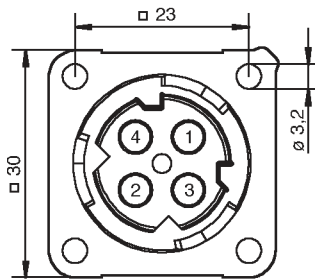

Order No.	Designation	Code	Color
121583-0004	APD-1AP-K2	1	black (RAL 9005)
121583-0005	APD-2AP-K2	2	grey (RAL 7036)
121583-0006	APD-3AP-K2	3	green (RAL 6029)
121583-0007	APD-4AP-K2	4	blue (RAL 5012)

Packaging unit 100 pcs.

Pin crimp contacts see page 32.
Accessories, see pages 32 and 33.

Coding, 4-way layouts

View on Mating Face

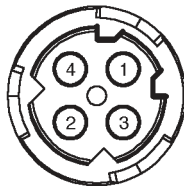

Code 1
black

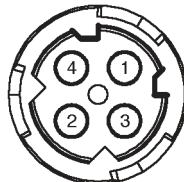

Code 2
grey

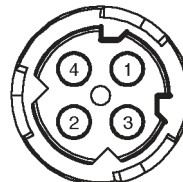

Code 3
green

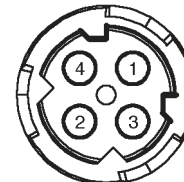

Code 4
blue

Note: The connectors offer both mechanical keying and visual coding by different colors.

Panel Cut Out

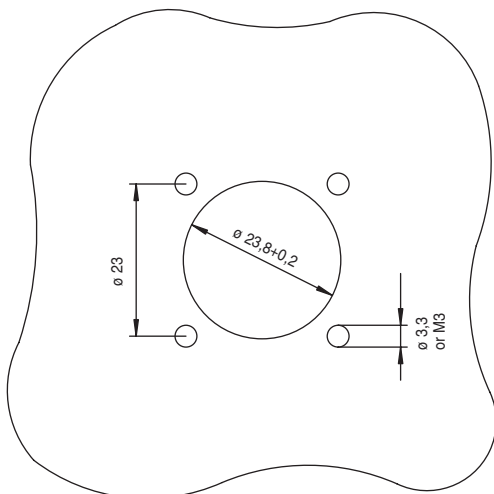

Flange for all Flange Receptacles

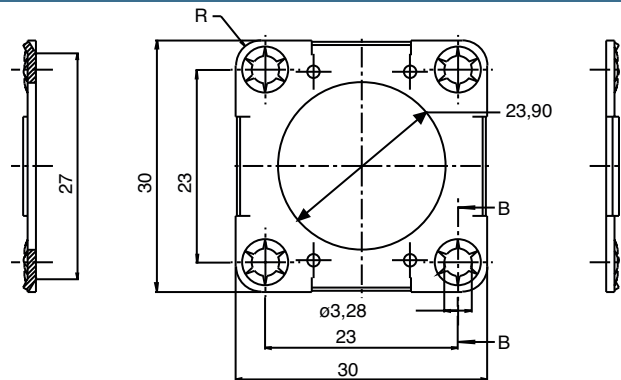

Order Number: 066-8516-005

Note: Metal mounting flange for wall mounting of flange receptacle.

Jam Nut Receptacle, 4-way

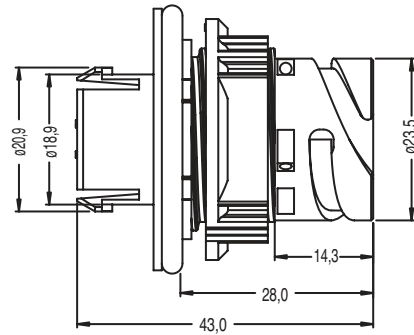
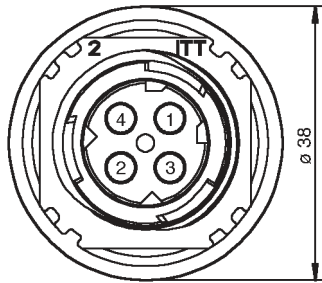

Order No.	Designation	Code	Color
121583-0008	APD-1CP-K2	1	black (RAL 9005)
121583-0009	APD-2CP-K2	2	grey (RAL 7036)
121583-0010	APD-3CP-K2	3	green (RAL 6029)
121583-0011	APD-4CP-K2	4	blue (RAL 5012)

Packaging unit 100 pcs.

Pin crimp contacts see page 32.
 Accessories, see pages 32 and 33.
 Note: Includes jam nut for wall thickness 1...4 mm.

Coding, 4-way layouts

View on Mating Face

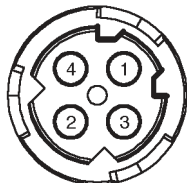

Code 1
black

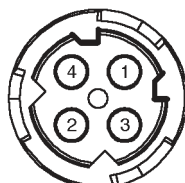

Code 2
grey

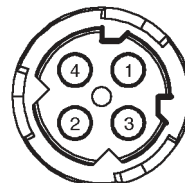

Code 3
green

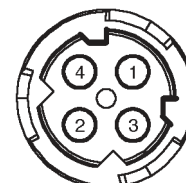

Code 4
blue

Note: The connectors offer both mechanical keying and visual coding by different colors.

Panel Cut Out

Piece Parts / Assembly Instruction

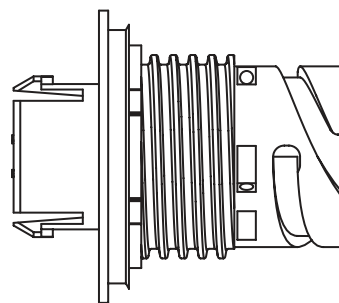
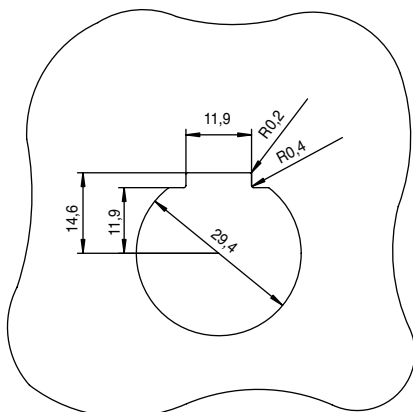

Housing



O-ring

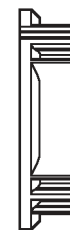

Jam Nut

Wall Thickness: Standard Jam Nut: min. 1,0 / max. 4,0 mm Special Jam Nut: min. 2,0 / max. 5,0 mm

Jam Nut, special

Designation	Order No.
for special wall thickness 2,0 - 5,0 mm	217-8516-001

Dimensions shown in mm
 Specifications and dimensions subject to change

APD 4-way connectors are the original DIN72585 (now ISO 15170) versions using a 2,5 mm contact system. Designed for automotive applications they also meet the requirements of transportation, off-road and special vehicle markets. ITT has come up with a new high voltage version of the APD 4-way connector.

Applications for the 4-way connector include:

- Sensors
- Traction / Skid Control
- Brake Control
- Magnetic Switch Control Systems
- Lightening systems on Trucks and Trailers
- Electric Vehicles



 Attention! Connector must not be disconnected under load!

Electrical Data

Operating Voltage	500 V DC/AC*
Operating Current	see derating curve
Contact Resistance	5 mΩ max.
Voltage Proof	3500 VAC, 30 seconds
Insulation Resistance	10 MΩ min.

Mechanical Data

Durability	50 Mating Cycles
Coupling Torque	1,2 Nm max.
Static Load, mated Connector	250 N axial, 150 N lat. (ISO 15170-2, Sec. 4.5)
Static Load, free connector	350 N (ISO 15170-2, Sec. 4.6)

Environmental Data (acc. ISO 15170)

Temperature Range	-40 °C up to 125 °C (ISO 15170-2, Sec. 6.4)
Humidity Range	up to 95 % r.h. (ISO 15170-2, Sec. 6.4)
Sealing	IP 67 and IP 69k (DIN EN 60529)*
Salt Spray	96 h, 35 °C (ISO 15170-2, Sec. 6.2)
Industrial Climate	SO ₂ , 0,67 % (ISO 15170-2, Sec. 6.3)
Fluid Compatibility	Brakefluid, ATF, fuel, .. (ISO 15170-2, Sec. 6.6)*
Vibration Resistance	Sine, 300m/s ² , 3 x 100h, RT and 120°C (ISO 15170-2)*

Materials List

Housing Parts	PBT GF
Sealing Parts	HNBR (alternative FKM)
Coupling Nut	PA 66 GF
Contacts	Copper Alloy, Sn or Au plated

* Further information available upon request

Dimensions shown in mm
Specifications and dimensions subject to change

Derating Curve

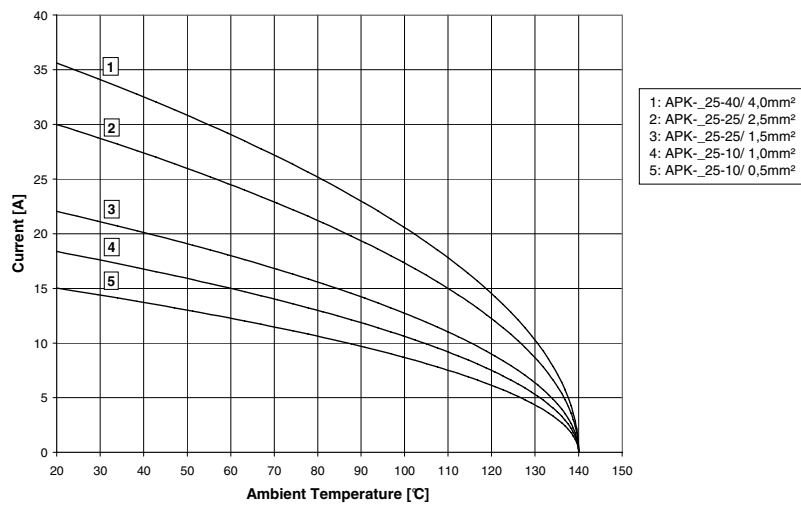

Plug, 4-way High Voltage

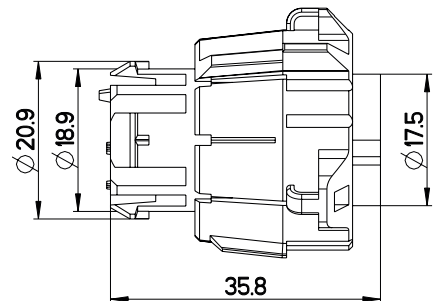
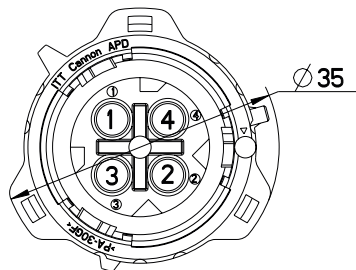

Order No.	Designation	Code	Color
121583-0213	APD-59BS-HV	5	orange (RAL 2003)
121583-0214	APD-69BS-HV	6	orange (RAL 2003)

Packaging unit 100 pcs.

Socket crimp contacts see page 32.
Accessories, see pages 32 and 33.

Coding, 4-way layouts High Voltage

View on Mating Face

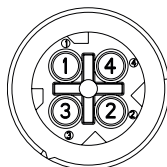

Code 5
orange

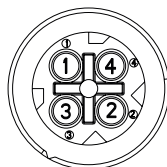

Code 6
orange

Note: The connectors offer both mechanical keying and visual coding by different colors.

Flange Receptacle, 4-way High Voltage

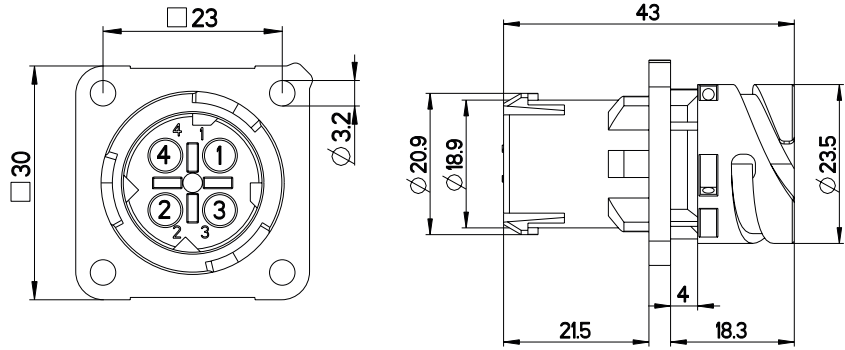

Order No.	Designation	Code	Color
121583-0215	APD-59AP-HV	5	orange (RAL 2003)
121583-0216	APD-69AP-HV	6	orange (RAL 2003)

Packaging unit 100 pcs.

Pin crimp contacts see page 32.
Accessories, see pages 32 and 33.

Coding, 4-way layouts High Voltage

View on Mating Face

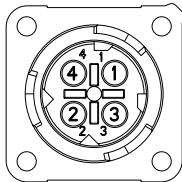

Code 5
orange

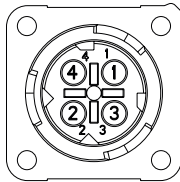

Code 6
orange

Note: The connectors offer mechanical keying.

Panel Cut Out

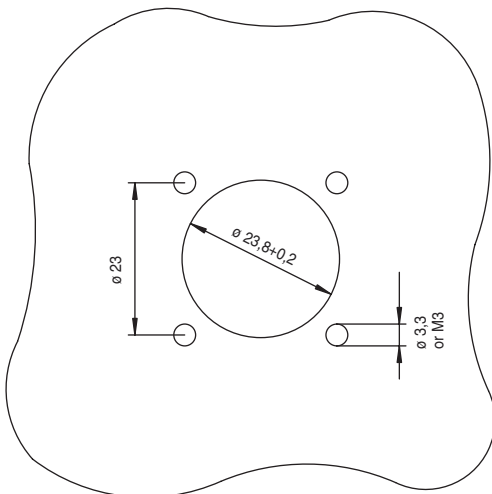

Flange for all Flange Receptacles

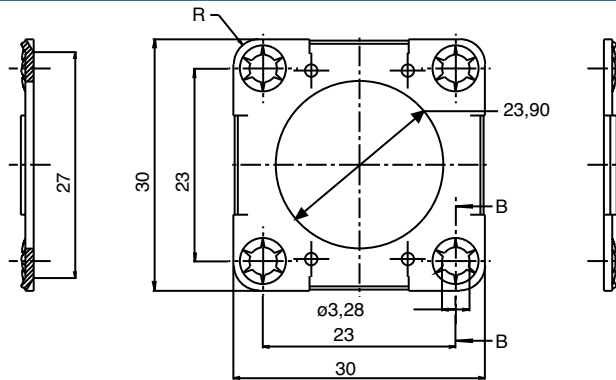

Order Number: 066-8516-005

Metal mounting flange for wall mounting of flange receptacle.

Dimensions shown in mm
Specifications and dimensions subject to change

Socket Crimp-Contacts Standard Tinned, 3000 contacts per reel

Designation - Standard	Order No.
APK-SB25A10-002 (0,5 - 1,5 mm ²)	121668-0125
APK-SB25A25-002 (1,5 - 2,5 mm ²)	121668-0126
APK-SB25A40-002 (2,5 - 4,0 mm ²)	121668-0127

Optional with Au-flash	
APK-SB25H10-002 (0,5 - 1,5 mm ²)	121668-0022
APK-SB25H25-002 (1,5 - 2,5 mm ²)	121668-0128
APK-SB25H40-002 (2,5 - 4,0 mm ²)	121668-0124

Note: For versions with silver plating please consult factory.

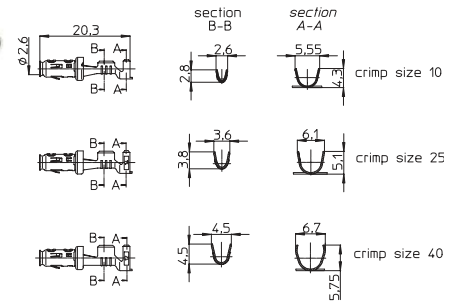

Pin Crimp-Contacts Standard Tinned, 3000 contacts per reel

Designation - Standard	Order No.
APK-PB25A10-002 (0,5 - 1 mm ²)	121668-0026
APK-PB25A25-002 (1,5 - 2,5 mm ²)	121668-0027
APK-PB25A40-002 (2,5 - 4,0 mm ²)	121668-0028

Optional with Au-flash	
APK-PB25H10-002 (0,5 - 1 mm ²)	121668-0021
APK-PB25H25-002 (1,5 - 2,5 mm ²)	121668-0029
APK-PB25H40-002 (2,5 - 4,0 mm ²)	121668-0025

Note: For versions with silver plating please consult factory.

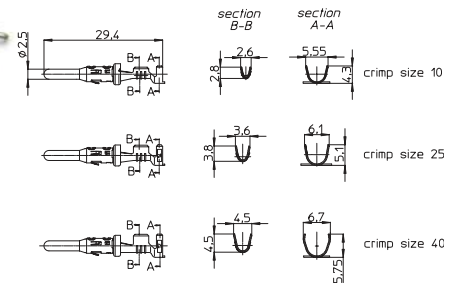

Individual Wire Seals

For all versions 4-way

Designation	Order No.
10RD5821 Wire insulation ϕ 1,4 - 2,0 mm / red	121668-0032
15BL5822 Wire insulation ϕ 2,1 - 2,9 mm / blue	121668-0033

Note: Packaging unit 5000 pcs.

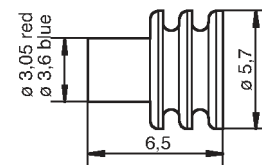

Wire Filler

For all versions 4-way

Designation	Order No.
15WH5823 white	121668-0034

Note: Packaging unit 5000 pcs.

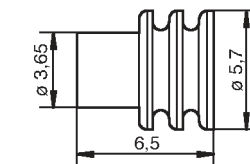

Flange Gasket

For Flange Receptacle, 4-way

Order No.
075-8503-000 (-55/125°C)
075-8503-004 (-30/200°C)

Packaging unit 100 pcs.

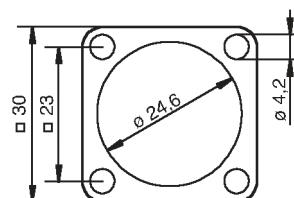

Sealing Cap for Receptacle

Designation	Order No.
APD-DP	121583-0021

Packaging unit 100 pcs.

APD-DP with rope, end link and eyelet
 X = Total rope length upon request

Order number 120110-0026* X~9cm

* for other lengths please consult the factory

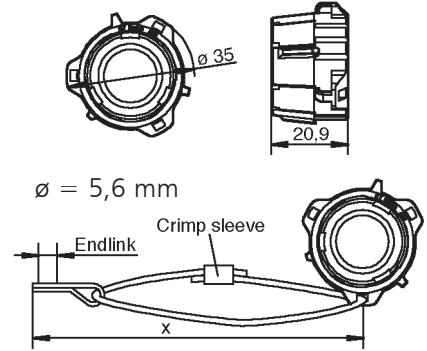

Straight Endbell for Flex Tube

Order No.	058-8578-100 (ø 8,5 mm)
	058-8578-102 (ø 10,0 mm)

Packaging unit 100 pcs.

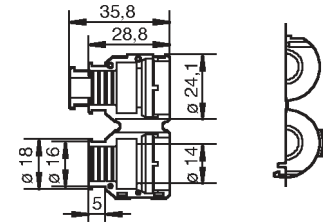

90° Endbell for Flex Tube

Order No.	058-8578-101 (ø 8,5 mm)
	058-8578-103 (ø 10,0 mm)
	058-8578-105 (ø 11,0 mm)

Packaging unit 100 pcs.

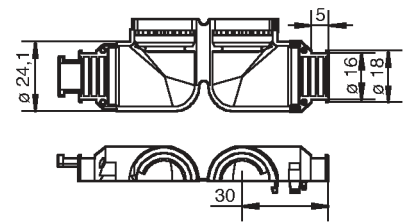

Dust Cap for Plug

Order No.	025-8636-005
-----------	--------------

Packaging unit 100 pcs.

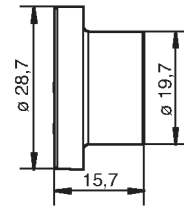

Dust Cap for Receptacle

Order No.	025-0480-000
-----------	--------------

Packaging unit 100 pcs.

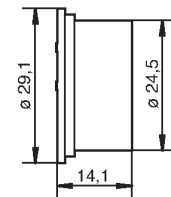

Blind Socket for 1 / 2 / 4 / 6 / 7-way

Order No.	120110-0217
-----------	-------------

Packaging unit 100 pcs.

Note: All cavities closed, mates with 1-7-way APD versions.

Dimensions shown in mm
 Specifications and dimensions subject to change

www.ittcannon.com



Crimp and Assembly Tools for APK 25 Contacts

Contact / Socket	Designation	Order No.
APK-SB25A10-002 (0,5 - 1,0 mm ₂)	CHT-APK-25-002-Seal	121586-5242
APK-SB25A25-002 (1,5 - 2,5 mm ₂)	CHT-APK-25-002-Seal	121586-5242
APK-SB25A40-002 (2,5 - 4,0 mm ₂)	CHT-APK-25-002-Seal	121586-5242

Contact / Pin	Designation	Order No.
APK-PB25A10-002 (0,5 - 1,0 mm ₂)	CHT-APK-25-002-Seal	121586-5242
APK-PB25A25-002 (1,5 - 2,5 mm ₂)	CHT-APK-25-002-Seal	121586-5242
APK-PB25A40-002 (2,5 - 4,0 mm ₂)	CHT-APK-25-002-Seal	121586-5242

Quick Change Tool for above Crimp Machine: (Mini Applicator)



Contact / Socket	Designation	Order No. (to be mentioned on order)
APK-SB25A10-002 (0,5 - 1,0 mm ₂)	WWZ.20-100-APK25-10-002	121586-5134
APK-SB25A25-002 (1,5 - 2,5 mm ₂)	WWZ.20-100-APK25-25-002	121586-5135
APK-SB25A40-002 (2,5 - 4,0 mm ₂)	WWZ.20-100-APK25-40-002	121586-5136
APK-SB25A40-002 (2,5 - 4,0 mm ₂)	WWZ-Mecal-APK25-40-002	121586-5249

Contact / Pin	Designation	Order No. (to be mentioned on order)
APK-PB25A10-002 (0,5 - 1,0 mm ₂)	WWZ.20-100-APK25-10-002	121586-5134
APK-PB25A25-002 (1,5 - 2,5 mm ₂)	WWZ.20-100-APK25-25-002	121586-5135
APK-PB25A40-002 (2,5 - 4,0 mm ₂)	WWZ.20-100-APK25-40-002	121586-5136
APK-PB25A40-002 (2,5 - 4,0 mm ₂)	WWZ-Mecal-APK25-40-002	121586-5249

Contact Extraction Tool



Order No.	Designation
121086-3278	CET-APK25

APD 6/7-way connectors are a derivative of the 4-way connector providing higher pin counts using a 1,6 mm connector system. They are available as versions with stamped and machined contacts.

Applications for the 6- and 7-way connector include:

- Sensors
- Traction / Skid Control
- Brake Control
- Magnetic Switch Control Systems
- Lightening systems on Trucks and Trailers



Electrical Data

Operating Voltage	48 VDC*
Operating Current	see derating curve
Contact Resistance	5 mΩ max.
Voltage Proof	1000 VAC, 60 seconds
Insulation Resistance	10 MΩ min.

Mechanical Data

Durability	50 Mating Cycles
Coupling Torque	1,2 Nm max.
Static Load, free connector	350 N (ISO 15170-2, Sec. 4.6)
Dynamic Impact	2 J (49mm- ball- drop- test, height 400mm)

Environmental Data (acc. ISO 15170)

Temperature Range	-40 °C up to 125 °C (ISO 15170-2, Sec. 6.4)
Humidity Range	up to 95 % r.h. (ISO 15170-2, Sec. 6.4)
Sealing	IP 67 and IP 69k (DIN EN 60529)*
Salt Spray	96 h, 35 °C (ISO 15170-2, Sec. 6.2)
Industrial Climate	SO ₂ , 0,67 % (ISO 15170-2, Sec. 6.3)
Fluid Compatibility	Brakefluid, ATF, fuel, .. (ISO 15170-2, Sec. 6.6)*
Vibration Resistance	Sine, 200m/s ² , 3 x 100h, RT and 120°C (ISO 15170-2)*

Materials List

Housing Parts	PBT GF
Sealing Parts	HNBR (alternative FKM)
Coupling Nut	PA 66 GF
Contacts	Copper Alloy, Sn or Au plated

*Further information upon request

Derating Curve

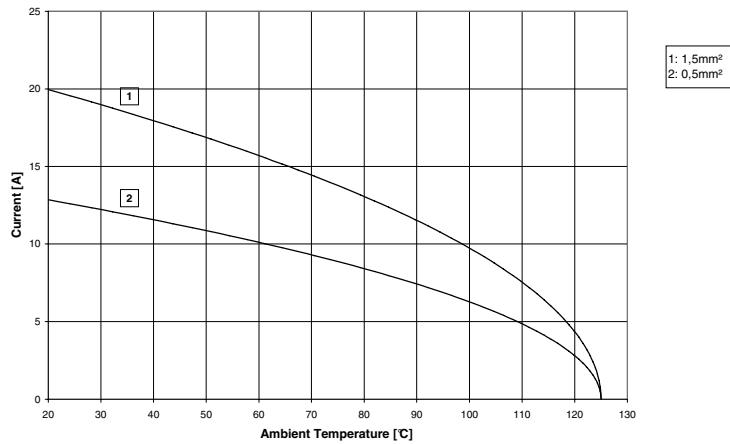

Plug, 6/7-way

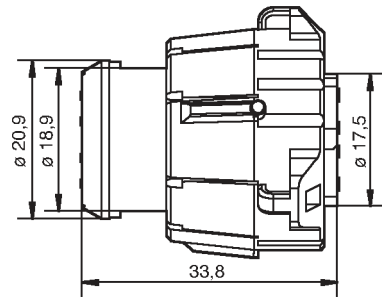
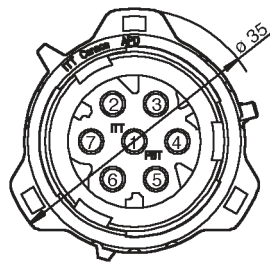

	Order No.	Designation	Code	Color
6-way*	120110-0024	APD-1BS6	1	black (RAL 9005)
7-way	121583-0211	APD-14BS7	1	blue (RAL 5012)
7-way	121583-0018	APD-1BS7	1	black (RAL 9005)

Packaging unit 100 pcs.

Socket crimp contacts see page 39.
 Accessories, see pages 39 and 40.
 *contact cavity 1 closed

Coding, 6/7-way layouts



6-way

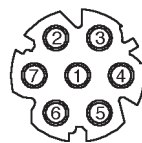

7-way

Jam Nut Receptacle, 6/7-way for standard contacts

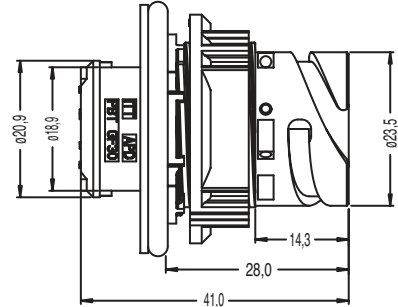
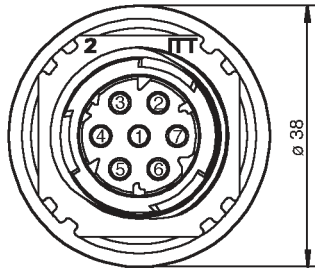

	Order No.	Designation	Code	Color
6-way*	121583-0061	APD-1CP6	1	black (RAL 9005)
7-way	121583-0019	APD-1CP7	1	black (RAL 9005)

Packaging unit 100 pcs.
* Contact cavity 1 closed

Jam Nut Receptacle, 6/7-way for crimp press-in contacts

	Order No.	Designation	Code	Color
6-way	on request	-	-	-
7-way	121583-0028	APD-1CP7-EP	1	black (RAL 9005)

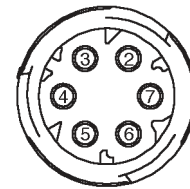

6-way

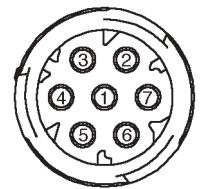

7-way

Press-in Crimp Contact

For Flange and Jam Nut Receptacle

Order No.
330-8672-021 (tinned) (0,75 - 1,5 mm²)
330-8672-019 (tinned) (0,35 - 0,75 mm²)
with gold flash plating upon request
Packaging unit 100 pcs.

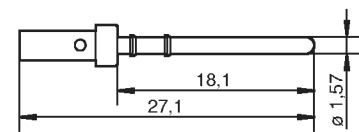

Tooling see page

Note: Press-in Crimp Contacts are not removable after insertion.

Panel Cut Out

Flange for all Flange Receptacles

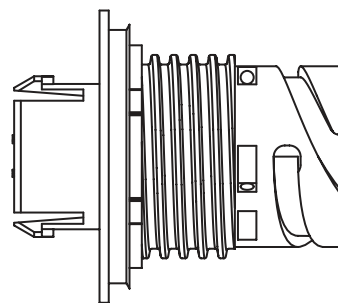
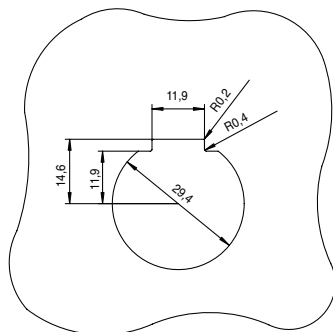

Housing



O-ring

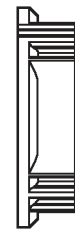

Jam Nut

Wall Thickness: Standard Jam Nut: min. 1,0 / max. 4,0 mm Special Jam Nut: min. 2,0 / max. 5,0 mm

Jam Nut, special

Designation	Order No.
for special wall thickness 2,0 - 5,0 mm	217-8516-001

Dimensions shown in mm
Specifications and dimensions subject to change

Flange Receptacle, 6/7-way for standard contacts

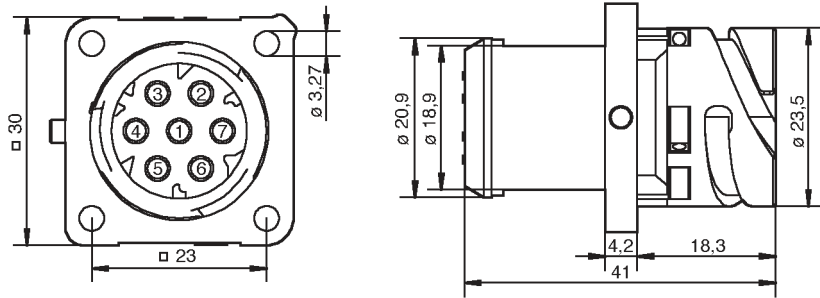

	Order No.	Designation	Code	Color
7-way	121583-0020	APD-1AP7	1	black (RAL 9005)
7-way	121583-0212	APD-14AP7-EP	1	blue (RAL 5012)
6-way*	120110-0083	APD-1AP6	1	black (RAL 9005)

Packaging unit 100 pcs.
* Contact cavity 1 closed

Flange Receptacle, 6/7-way for crimp press-in contacts

	Order No.	Designation	Code	Color
6-way*	120110-0020	APD-1AP6-EP	1	black (RAL 9005)
7-way	121583-0205	APD-1AP7-EP	1	black (RAL 9005)

Packaging unit 100 pcs.
* Contact cavity 1 closed

Pin crimp contacts see page 39.
Accessories, see pages 39 and 40.

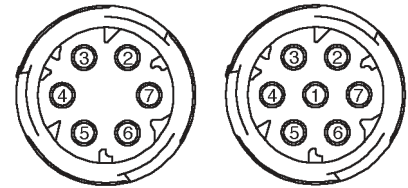

6-way

7-way

Press-in Crimp Contact For Flange and Jam Nut Receptacle

Order No.
330-8672-021 (tinned) (0,75 - 1,5 mm)
330-8672-019 (tinned) (0,35 - 0,75 mm)
with gold flash plate upon request
Packaging unit 100 pcs.

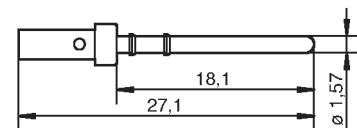

Note: Press-in Crimp Contacts are not removable after insertion.

Panel Cut Out Flange for all Flange Receptacles

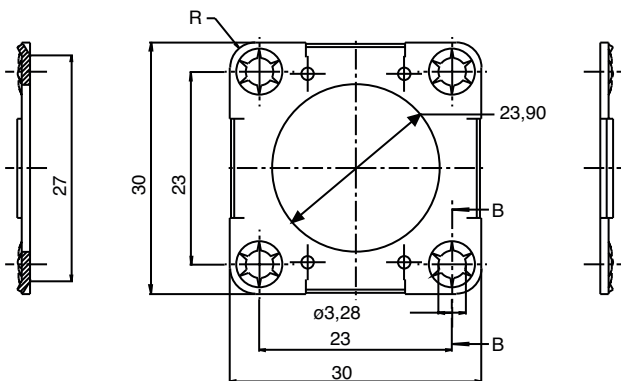
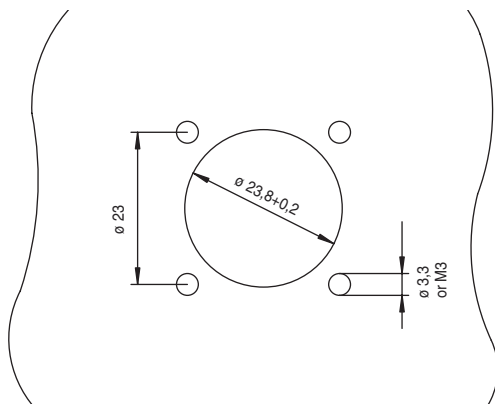

Socket Crimp-Contacts 1,6 mm Standard Tinned, 3000 contacts per reel

Order No. 192900-0001 (0,5 - 1,5 mm₂)
 *192900-0003 Loose Piece Bulk Pack

* Crimp Tool - 121586-5237

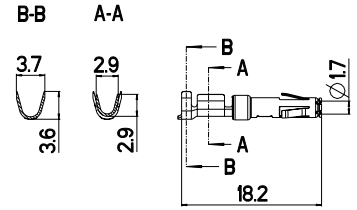

Pin Crimp-Contacts 1,6 mm Standard Tinned, 3000 contacts per reel

Order No. 192900-0000 * (0,5 - 1,5 mm₂)
 192900-0002 Loose Piece Bulk Pack

* Crimp Tool - 112108-0014

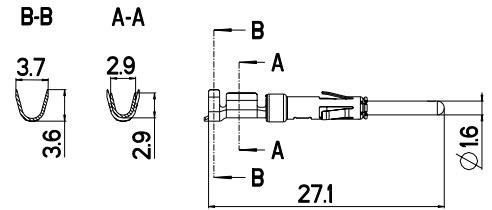

Individual Wire Seals

Designation	Order No.
Wire insulation ø 1,4 - 2,0 mm / grey	121667-0022
Wire insulation ø 1,9 - 2,1 mm / yellow	121667-0023
Wire insulation ø 1,2 - 1,6 mm / red	121667-0024

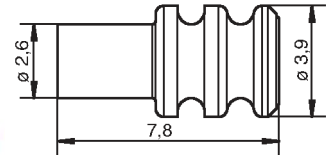

Wire Filler

Designation	Order No.
10WH3940	121667-0025

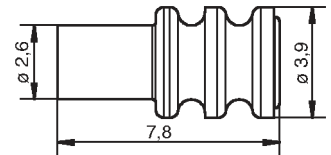

Gasket for all Flange Receptacles

Order No.
 075-8503-000 (-55/125°C)
 075-8503-004 (-30/200°C)

Packaging unit 100 pcs.

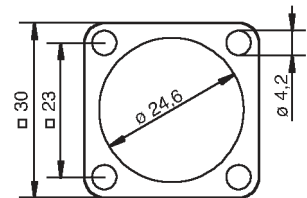

Blind Socket for 1 / 2 / 4 / 6 / 7-way

Order No. 120110-0217

Packaging unit 100 pcs.

Note: All cavities closed, mates with 1-7-way APD versions.



Dimensions shown in mm
 Specifications and dimensions subject to change

Sealing Cap for Receptacle

Designation Order No.
 APD-DP 121583-0021

Packaging unit 100 pcs.

APD-DP with rope, end link and eyelet
 X = Total rope length upon request

Order number 120110-0026* X~9cm

* for other lengths please consult the factory

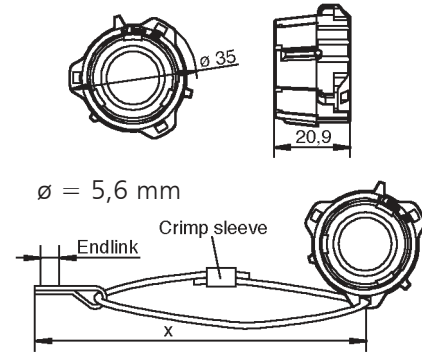

Straight Endbell for Flex Tube

Order No. 058-8578-100 (ø 8,5 mm)
058-8578-102 (ø 10,0 mm)

Packaging unit 100 pcs.

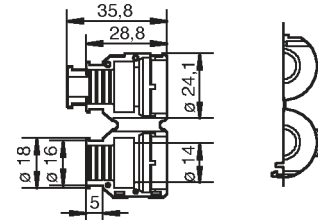

90° Endbell for Flex Tube

Order No. 058-8578-101 (ø 8,5 mm)
058-8578-103 (ø 10,0 mm)
058-8578-105 (ø 11,0 mm)

Packaging unit 100 pcs.

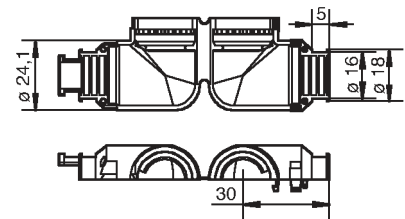

Dust Cap for Plug

Order No. 025-8636-005

Packaging unit 100 pcs.

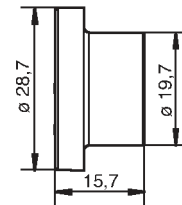

Dust Cap for Receptacle

Order No. 025-0480-000

Packaging unit 100 pcs.

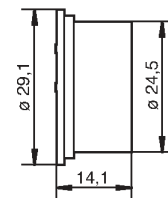

Hand Tool for formed (stamped contacts)



Contact Pin	Contact Socket	Designation	Order No.(to be mentioned on order)
192990-0100	192990-0110	CHT-Trident-16-18	121586-5237
192900-0446	192900-0450	CHT-Trident-16-18	121586-5237
192990-0060	192990-0070	CHT-Trident-16-18	121586-5237
192900-0002	192990-0003	CHT-Trident-16-18	121586-5237

Quick Change Tool for above Crimp Machine: (Mini Applicator)



Contact / Socket	Designation (to be mentioned on order)	Order No.
192900-0001 (0,75 - 1,5 mm ²)	WWZ-Mecal-16-18-EVS	121586-5217
Contact / Socket	Designation (to be mentioned on order)	Order No.
192900-0000 (0,75 - 1,5 mm ²)	WWZ-Mecal-16-18-EVS	121586-5217

Contact Extraction Tool



Description	Order No.
Trident Extraction Tool Wire Insulation Stripping length: 4,5 mm	192922-1450

Crimp and assembly Tools for press in contacts



Basic - Hand Crimp Tool	Order No.
M22520-1-01	995-0001-585
Turret	120190-0163

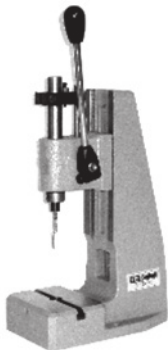

Insertion Tool	Order No.
CIT-APD 16-TIP	317-8648-008
Hand Lever - Press	Order No.
CHPZ-240	121586-0081
Ragged Tool	Order No.
	192990-7600

Dimensions shown in mm
Specifications and dimensions subject to change

APD Sensor connectors are special 1-4-way versions based on the ISO 15170 4-way layout. They are designed to be directly adapted to sensor housing and typically customized versions. The offering includes several basic versions / variations for pressure sensing and options for flow solder and crimp contacts.



Typical Applications include:

- Pressure Sensing (absolute and relative)
- Temperature Sensing
- Humidity Sensing

Sensor Connectors, Style 1



Order No.	Code	Contact Cavity closed no.	Color
248-8653-031	1	3 + 4	black (RAL 9005)
248-8653-053	2	3 + 4	grey (RAL 7036)
248-8653-105	1	4	black (RAL 9005)
248-8653-106	1	-	black (RAL 9005)
248-8653-134	4	2 + 4	blue (RAL 5012)

Consult factory for customized versions.
Note: Mate with APD 4-way plug.

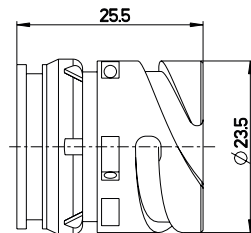
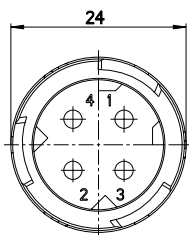

Coding, Basic layouts*

View on Mating Face

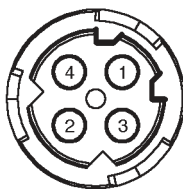

Code 1
black

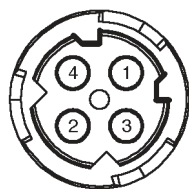

Code 2
grey

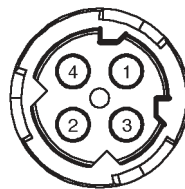

Code 3
green

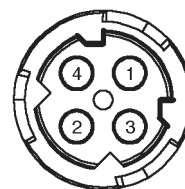

Code 4
blue

Note: The connectors offer both mechanical keying and visual coding by different colors.

* Versions with closed cavities are not shown.

Sensor Connectors, Style 2

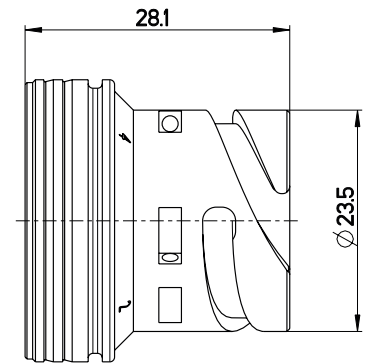
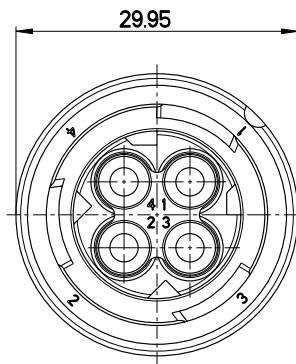

* Pictures and drawings shown are examples.

Consult factory for details. Products can be supplied with:

- Codings 1, 2, 3 and 4
- Partially closed cavities
- Ventilation pin for absolute pressure application

Contacts (machined)

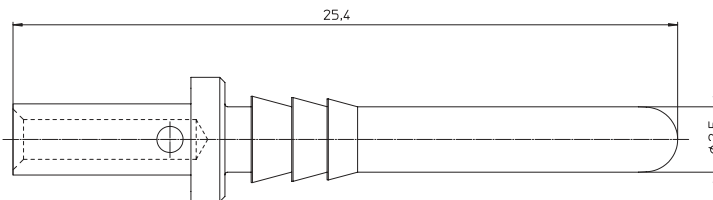

- 2,5 mm contact diameter
- PCB versions available
- Press-in types

Order Design	Order No.	Crimp Wire Size
AP120110-13	120110-0013	0,15 - 0,38 mm ²
AP120110-11	120110-0011	0,5 - 1,0 mm ²
AP120110-14	120110-0014	0,75 - 1,5 mm ²

APD 19-way is the latest addition to ITT's APD connector range. Based on ISO 15170 it adds additional features to the standard harsh environment capabilities.

Secondary lock, adaptation of market available standard accessories and ease of assembly and disassembly not demanding any special tooling characterize this connector. Moreover, APD 19 is set up around a flexible design platform which allows for customized solutions up to 27 contacts.

Applications for the 19-way include:

- Trucks, Busses, and Tractors
- Motor / Electronic Control Units
- Transmission
- Chassis wire-to-wire and Cabin pass through
- Industrial automation and instrumentation



Electrical Data

Operating Voltage	48 VDC*
Operating Current	See derating curve
Contact Resistance	5 mΩ max.
Voltage Proof	1000 VAC, 60 seconds
Insulation Resistance	10 MΩ min.

Mechanical Data

Durability	50 Mating Cycles
Coupling Torque	3,5 Nm max.
Static Load, free connector	250 N axial, 150 N lat. (ISO 15170-2, Sec. 4.5)
Dynamic Impact	Free fall with cable (EN 61984 Sec. A9, height 1m)

Environmental Data (acc. ISO 15170)

Temperature Range	-40 °C up to 125 °C (ISO 15170-2, Sec. 6.4)
Humidity Range	up to 95 % r.h. (ISO 15170-2, Sec. 6.4)
Sealing	IP 67 + IP 69k (DIN EN 60529)
Salt Spray	96 h, 35 °C (ISO 15170-2, Sec. 6.2)
Industrial Climate	SO ₂ , 0,67 % (ISO 15170-2, Sec. 6.3)
Fluid Compatibility	Brakefluid, ATF, fuel, .. (ISO 15170-2, Sec. 6.6)*
Vibration Resistance	Sine, 300m/s ² , 3 x 100h, RT and 120°C (ISO 15170-2)*

Materials List

Housing Parts	PBT GF
Sealing Parts	FKM
Coupling Nut	PA 46 GF
Contacts	Copper Alloy, Au, Ag or Sn plated*

* Further information available upon request.

Derating Curve

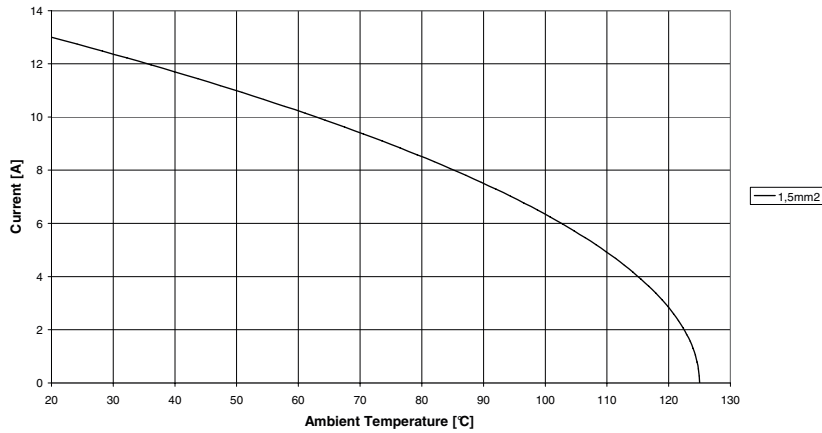

Plug, 19-way

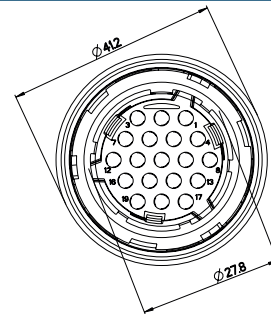
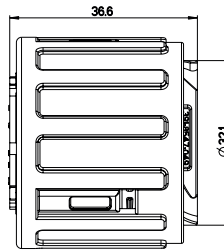

Order No.	Designation	Code	Color
121583-0119	APD-1BS19S	1	black (RAL 9005)
121583-0121	APD-2BS19S	2	grey (RAL 7036)
121583-0123	APD-3BS19S	3	green (RAL 6029)
121583-0125	APD-4BS19S	4	blue (RAL 5012)

Packaging unit 50 pcs.

Note: Each packaging unit includes one release tool.

Socket crimp contacts see page 49.
Accessories, see pages 50, 51, and 52.

Coding, 19-way layouts

Code 1
black

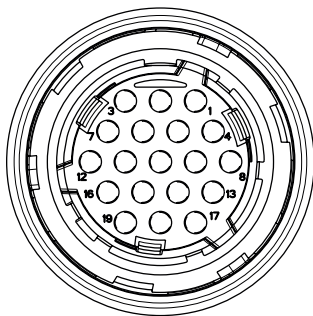

Code 2
grey

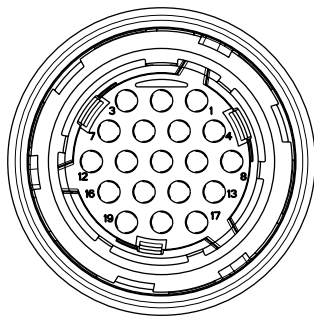

Code 3
green

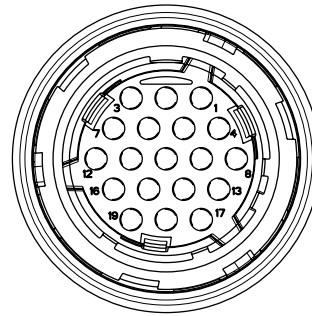

Code 4
blue

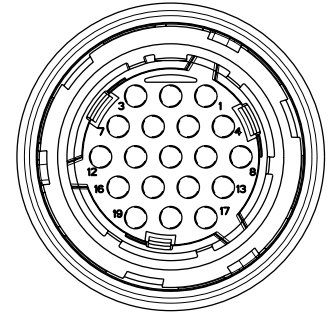

Flange Receptacle, 19-way

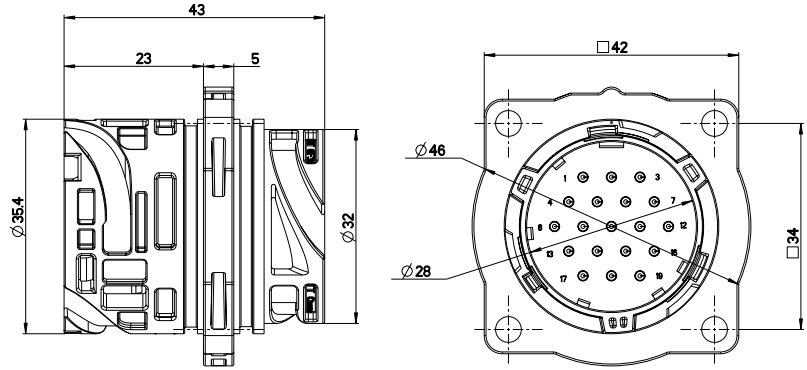

Order No.	Designation	Code	Color
121583-0120	APD-1AP19S	1	black (RAL 9005)
121583-0122	APD-2AP19S	2	grey (RAL 7036)
121583-0124	APD-3AP19S	3	green (RAL 6029)
121583-0126	APD-4AP19S	4	blue (RAL 5012)

Version with o-ring for rear panel mounting:

Order No.	Designation	Code	Color
121583-0127	APD-1AP19S-R	1	black (RAL 9005)
121583-0129	APD-2AP19S-R	2	grey (RAL 7036)
121583-0131	APD-3AP19S-R	3	green (RAL 6029)
121583-0133	APD-4AP19S-R	4	blue (RAL 5012)

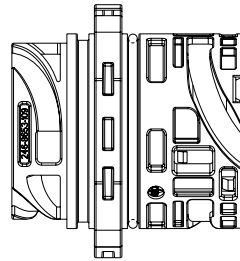

Version with o-ring for front panel mounting:

Order No.	Designation	Code	Color
121583-0128	APD-1AP19S-F	1	black (RAL 9005)
121583-0130	APD-2AP19S-F	2	grey (RAL 7036)
121583-0132	APD-3AP19S-F	3	green (RAL 6029)
121583-0134	APD-4AP19S-F	4	blue (RAL 5012)

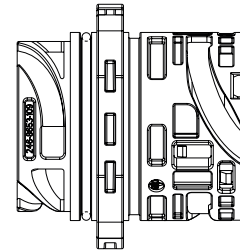

Packaging unit 50 pcs.

Note: Each packaging unit includes one release tool.

Pin crimp contacts see page 49.
Accessories, see pages 50, 51, and 52.

Coding, 19-way layouts

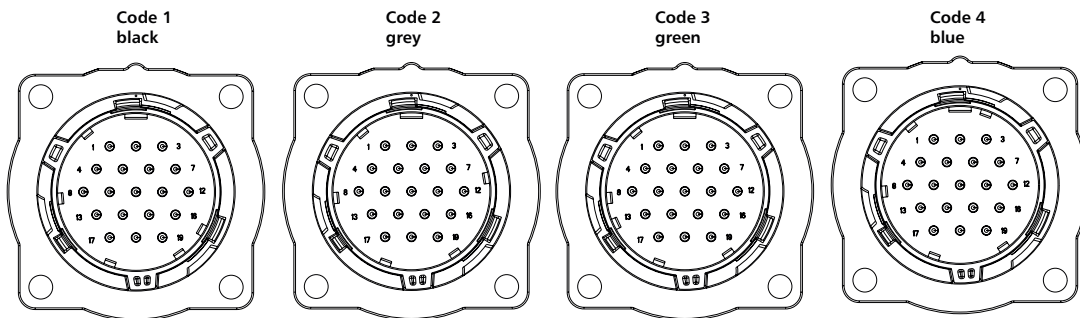

Panel Cut Out

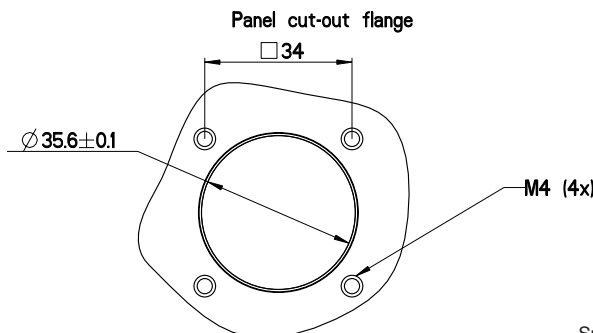

Dimensions shown in mm
Specifications and dimensions subject to change

www.ittcannon.com

Wire-to-Wire Receptacle, 19-way

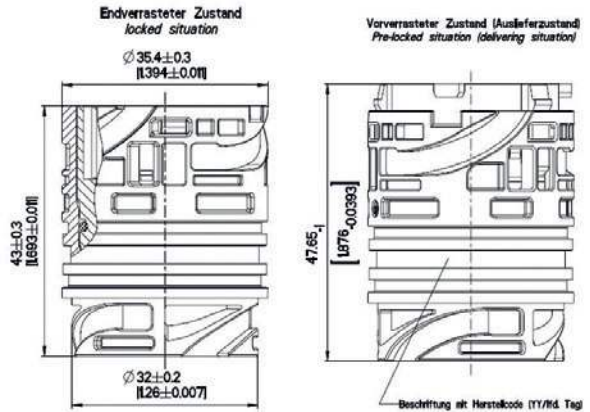

Order No.	Designation	Code	Color
121583-0135	APD-1BP19S	1	black (RAL 9005)
121583-0136	APD-2BP19S	2	grey (RAL7036)

Coding, 19-way layouts

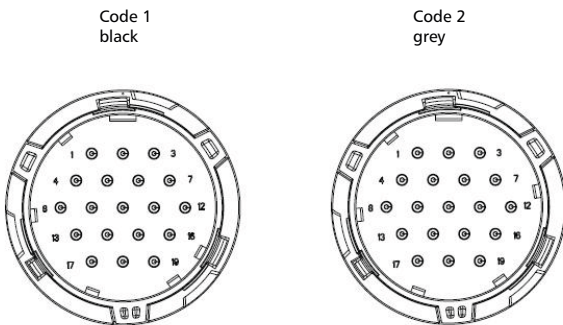

Dimensions shown in mm
 Specifications and dimensions subject to change

Jam Nut Receptacle, 19-way

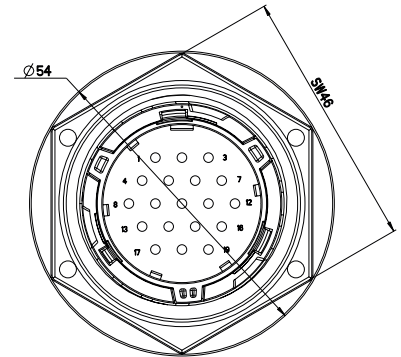
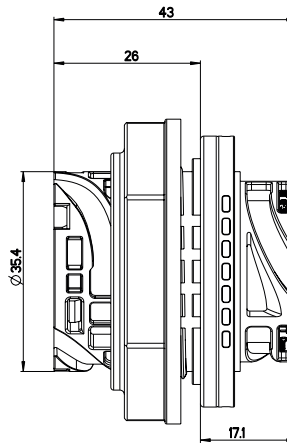
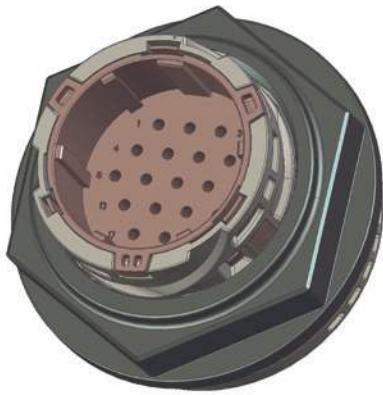

Order No.	Designation	Code	Color
Consult Factory	APD-1CP19S	1	black (RAL 9005)
Consult Factory	APD-2CP19S	2	grey (RAL 7036)
Consult Factory	APD-3CP19S	3	green (RAL 6029)
Consult Factory	APD-4CP19S	4	blue (RAL 5012)

Packaging unit 50 pcs.

Note: Each packaging unit includes one release tool.

Pin crimp contacts see page 49.
Accessories, see pages 50, 51, and 52.

Coding, 19-way layouts

Keying positions: See coding, 19-way layouts plug or flange receptacle.

Panel Cut Out

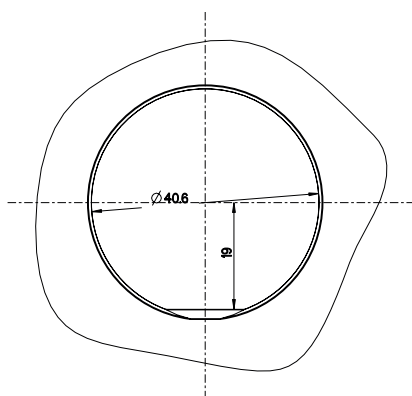

Piece Parts, Assembly Instructions

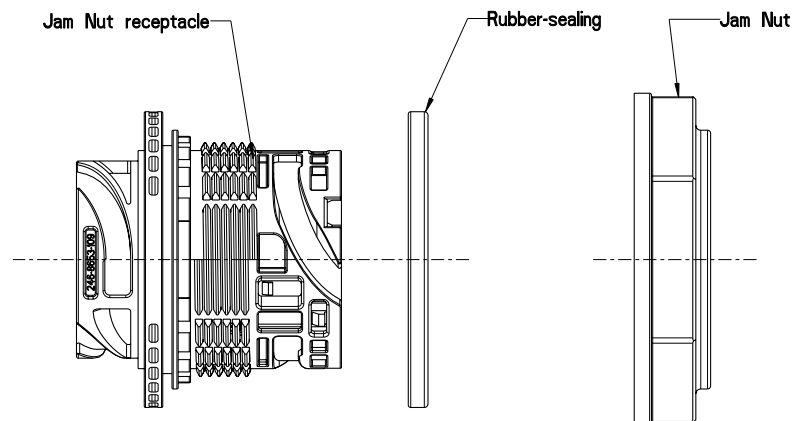

Dimensions shown in mm
Specifications and dimensions subject to change

CONTACTS



- Low contact resistance (max. 5mΩ) for maximum signal integrity
- Current carrying capacity: 12A max.
- Machined press-in contacts. (other machined contacts available on request)
- Silver plating, please consult factory

For 19-way

Contacts (stamped & formed)	Plating	Crimp Range	Reeled (5000 pcs)		Loose Piece (bags of 100)	
			Designation	Part number	Designation	Part number
Socket contacts	tin	0,35 - 0,75 mm ²	APK-SA16A07-002	121668-0221	APK-SA16A07-002-B	121668-0274
		0,75 - 1,5 mm ²	APK-SA16A15-002	121668-0202	APK-SA16A15-002-B	121668-0276
	gold (0,8 μm)	0,35 - 0,75 mm ²	APK-SA16G07-002	121668-0270	APK-SA16G07-002-B	121668-0278
		0,75 - 1,5 mm ²	APK-SA16G15-002	121668-0272	APK-SA16G15-002-B	121668-0280
Pin contacts	tin	0,35 - 0,75 mm ²	APK-PA16A07-002	121668-0252	APK-PA16A07-002-B	121668-0275
		0,75 - 1,5 mm ²	APK-PA16A15-002	121668-0253	APK-PA16A15-002-B	121668-0277
	gold (0,8 μm)	0,35 - 0,75 mm ²	APK-PA16G07-002	121668-0269	APK-PA16G07-002-B	121668-0279
		0,75 - 1,5 mm ²	APK-PA16G15-002	121668-0271	APK-PA16G15-002-B	121668-0281

Press-In Contacts

Contacts (machined)	Plating	Crimp Range	Reeled		Single piece	
			Designation	Part number	Designation	Part number
Pin contacts	tin	0,3 - 0,6 mm ²	-	-	APK-PA16A06-E	Consult Factory
		0,3 - 0,6 mm ²	-	-	APK-PA16G06-E	Consult Factory
	gold (0,8 μm)	0,5 - 1,0 mm ²	-	-	APK-PA16G10-E	Consult Factory
		1,0 - 1,5 mm ²	-	-	APK-PA16G15-E	Consult Factory

Individual Wire Seals / Blind Seals

Description	Insulation Diameter	Color	Part Number
Single Wire Sealing	1,2 - 1,6 mm	Red	121667-0024
	1,4 - 2,0 mm	Grey	121667-0022
	1,9 - 2,1 mm	Yellow	121667-0023
Blind Seal	1,4 - 2,0 mm	White	121667-0025

Endbell, 19-way

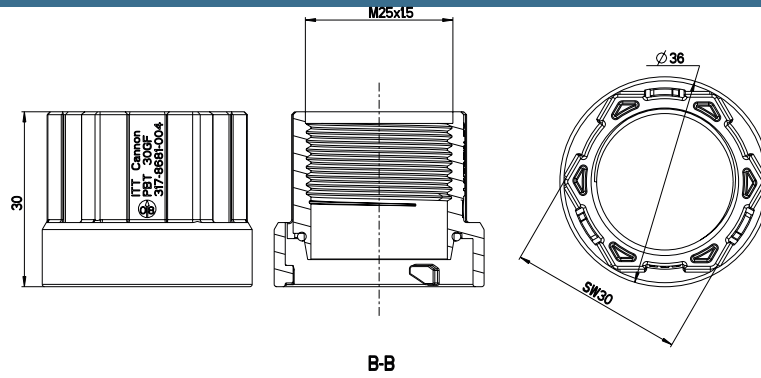

Order No.	Designation	
044-8597-002	Endbell for APD 19 version only	black (RAL 9005)

Endbell Adapter, 19-way, for the use of standard 90° / Straight conduit accessories

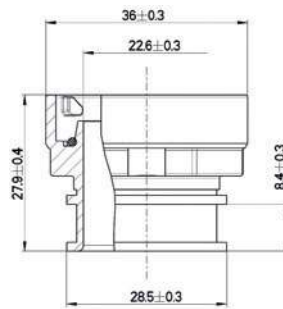

Order Number: 044-8597-004*

* Can be used in combination with PN 980-8672-034. Further adapters available upon request.

Dust Cap for Plug



Order Number: 025-8636-053

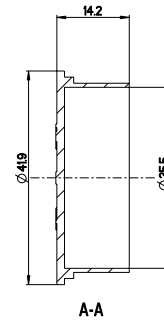

Dust Cap for Receptacle



Order Number: 025-0487-000

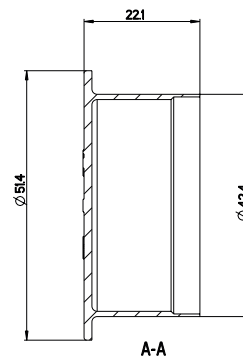

90° Endbell for Flex Tube

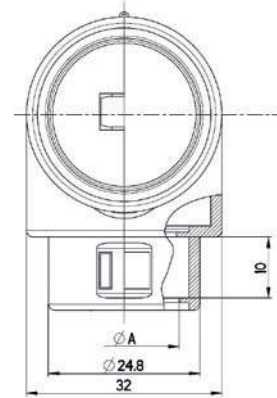
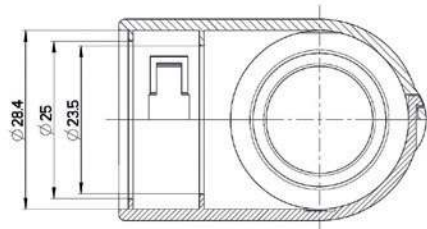

Order No.	Designation	Color	ø A	Nominal Dimension of Conduit
980-8672-034	90° Endbell Adapter	black	18	17
980-8672-035	90° Endbell Adapter	black	14	13

Packaging unit 100 pcs.

Flange Gasket, 19-way

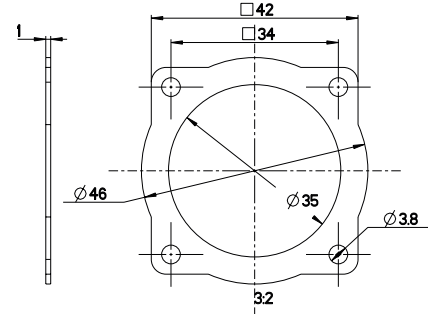
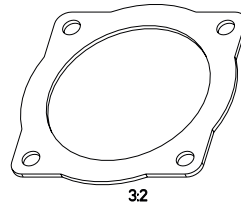

Order Number: 075-8566-003

Conduit Adaptors, 19-way



Order No.

Designation

980-8672-015	90°, M25, NW23
980-8672-016	Straight, M25, NW17
980-8672-018	Elbow, M25, NW17
980-8672-020	45°, M25, NW23

All versions in black color

Conduit Retainers, 19-way



Order No.

Designation

980-8672-021	NW17
--------------	------

All versions in black color

Conduit Splitters, 19-way



Order No.

Designation

980-8672-017	Y-Splitter 17X17X23
980-8672-019	T-Splitter 17X17X17

All versions in black color

Note: Other versions available, consult factory for more information.

Hand Crimp Tool for Stamped and Formed Contacts



Contact Die	Hand Tool	Crimp
0,35 - 0,75 mm ²	121586-5156	121586-5260
0,75 - 1,5 mm ²	121586-5156	121586-5197

Mini Applicator for Stamped and Formed Contacts



Contact	Order No.	Designation
0,35 - 0,75 mm ²	121586-5131	WWZ-20-100-APK16-07-002
0,75 - 1,5 mm ²	121586-5132	WWZ-20-100-APK16-15-002

Support Tools, 19-way

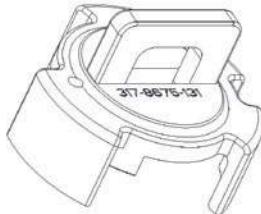

Designation	Order No.*
Release tool, secondary lock, plug	121586-5235
Release tool, secondary lock, receptacle	121586-5234

*Packaging unit of 50 pcs.

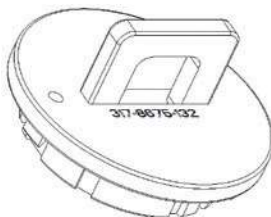

Assembly Adaptor	Order No.
MA-APD-19	Consult Factory

Locking tool for 19-way plug connectors

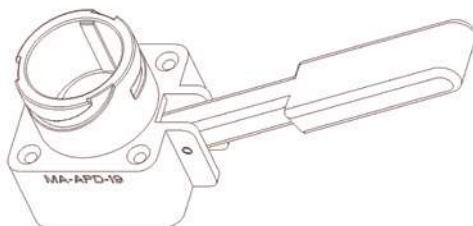

Hand Crimp Tool for Press-in Contacts



Basic Hand Crimp Tool No.	Order
M225201/1-01	995-0001-585

Locator No.	Order
M225201/1-05	995-0001-507

Automatic Crimp Tooling for Press-in Contacts



Designation	Order No.	Description
WAz7F-CE	121586-5067	Pneumatic Tool
M22501/1-05	995-0001-507	Locator
BM-2	121586-5068	Bench Mount
WA-10	121586-5069	Food Pedal

Assembly Tooling for Press-in Contacts

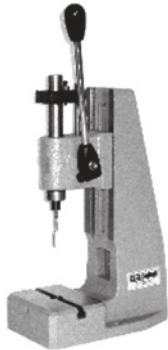

Designation	Order No.	Description
CHPZ-240	121586-0081	Hand Lever Press
CIT-APD16-TIP	317-8648-008	Mounting Tip

APD 37-way is a highly reliable, cost effective multi-pin connector with signal contacts (multi-layout power / signal on demand). It offers wire-to-wire and wire-to-board connection solutions. According to ISO 15170, the connector is dedicated for harsh environmental usage. Various customer specific designs (e.g. different coding) are possible.



Electrical Data

Operating Voltage	48 VDC*
Operating Current	see derating curve
Contact Resistance	5 mΩ max.
Voltage Proof	1000 VAC, 60 seconds
Insulation Resistance	10 MΩ min.

Mechanical Data

Durability	20 Mating Cycles
Coupling Torque	4 Nm max.
Static Load, free connector	250 N axial, 150 N lat. (ISO 15170-2, Sec. 4.5)
Dynamic Impact	Free fall with cable (EN 61984 Sec. A9, height 1m)

Environmental Data (acc. ISO 15170)

Temperature Range	-40 °C up to 125 °C (ISO 15170-2, Sec. 6.4)
Humidity Range	up to 95 % r.h. (ISO 15170-2, Sec. 6.4)
Sealing	IP 67 + IP 69k (DIN EN 60529)
Salt Spray	96 h, 35 °C (ISO 15170-2, Sec. 6.2)
Industrial Climate	SO ₂ , 0,67 % (ISO 15170-2, Sec. 6.3)
Fluid Compatibility	Brakefluid, ATF, fuel, .. (ISO 15170-2, Sec. 6.6)*
Vibration Resistance	Sine, 300m/s ² , 3 x 100h, RT and 120°C (ISO 15170-2)*

Materials List

Housing Parts	PA 66 GF
Sealing Parts	FKM (alternative FVMQ)
Coupling Nut	PA 6 GF
Contacts	Copper Alloy, Au or Sn plated*

*Further information on request

Derating Curve

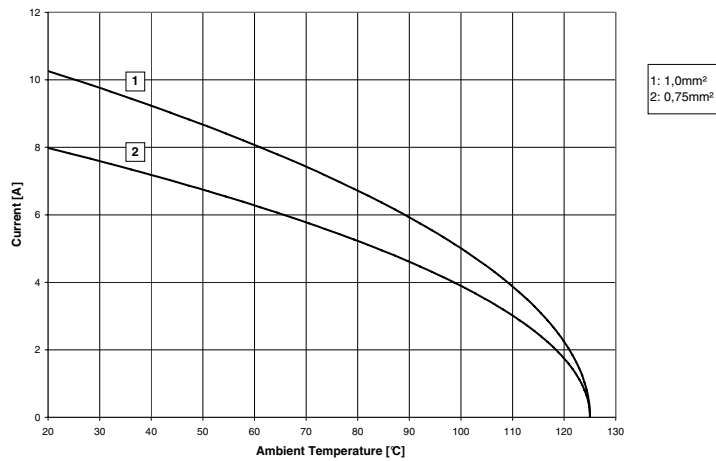

Plug, 37-way

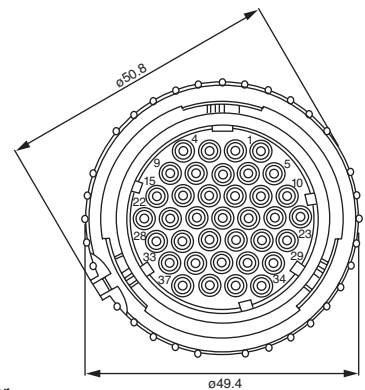
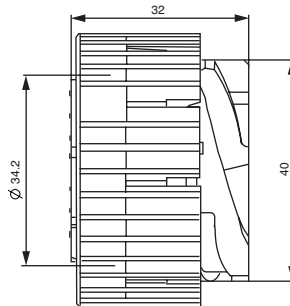
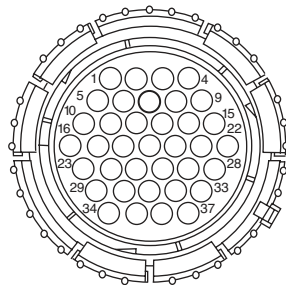

Order No.	Designation	Code	Color
121583-0058	APD-1B537	1	black (RAL 9005)

Packaging unit 100 pcs.

Socket crimp contacts see page 58.
Accessories, see pages 58 and 59.

Coding 37-way layout

View on Mating Face

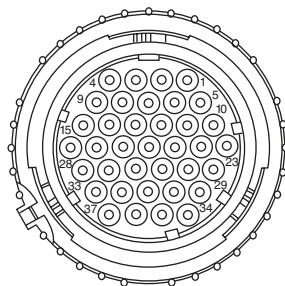

Note: Additional coding on demand.



Flange Receptacle, 37-way

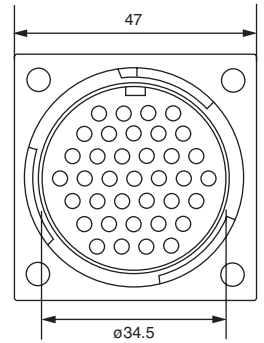
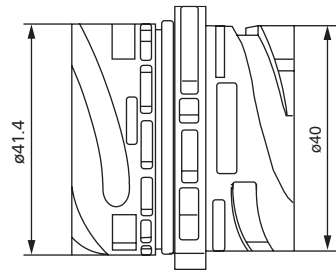
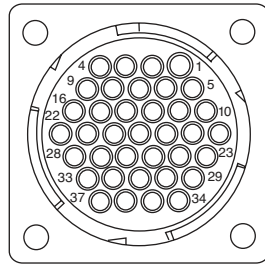

Order No.	Designation	Code	Color	Comment
249-8619-017	APD-1AP37-R	1	black (RAL 9005)	with O-ring
248-8653-026	APD-1AP371		black (RAL 9005)	without O-ring

Packaging unit 100 pcs.

Pin crimp contacts see page 58.

Accessories, see pages 58 and 59.

Note: Requires use of alignment disc.

Coding 37-way layout

View on Mating Face

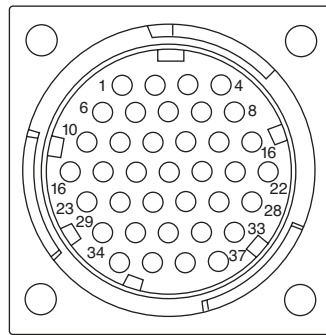

Note: Additional coding on demand.

Panel Cut Out

Flange for all Flange Receptacles

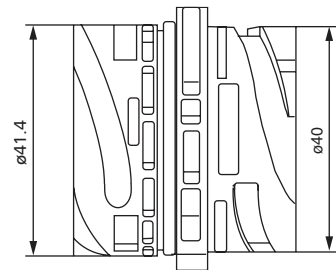
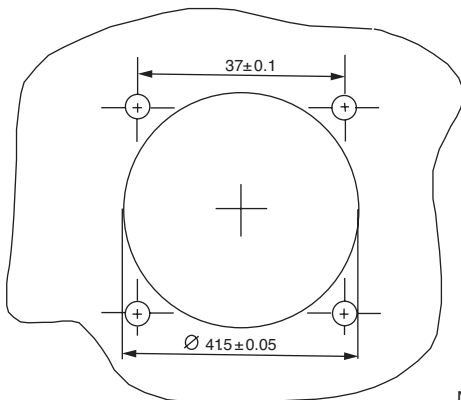

Note: Dimension if used as version with radial o-ring seal (249-8619-017).

CONTACTS



- Low contact resistance (max. 5mΩ) for maximum signal integrity
- Current carrying capacity: 12A max.
- Machined press-in contacts. (other machined contacts available on request)
- Silver plating, please consult factory

For APD 37-way

Contacts (stamped & formed)	Plating	Crimp Range	Reeled 5000 pcs/reel	
			Designation	Part Number
Socket Contacts	tin	0,35 - 0,75 mm ²	APK-SA16A07-002-C	121668-0220
		0,75 - 1,50 mm ²	APK-SA16A15-002-C	121668-0222
	gold (0,8 μm)	0,35 - 0,75 mm ²	APK-SA16G07-002-C	121668-0266
		0,75 - 1,50 mm ²	APK-SA16G15-002-C	121668-0268
Pin Contacts	tin	0,35 - 0,75 mm ²	APK-PA16A07-002-C	121668-0254
		0,75 - 1,50 mm ²	APK-PA16A15-002-C	121668-0255
	gold (0,8 μm)	0,35 - 0,75 mm ²	APK-PA16G07-002-C	121668-0265
		0,75 - 1,50 mm ²	APK-PA16G15-002-C	121668-0267
Press-In Contacts (machined)				
Pin Contacts	tin	0,30 - 0,60 mm ²	APK-PA16A06-E	330-8674-020
	gold (0,8 μm)	0,50 - 1,00 mm ²	APK-PA16G10-E	330-8674-025

Individual Wire and Blind Seals

Description	Insulation Diameter	Color	Part Number
Single Wire Sealing	1,2 - 1,6 mm	Red	121667-0024
	1,4 - 2,0 mm	Grey	121667-0022
	1,9 - 2,1 mm	Yellow	121667-0023
Blind Seal		White	121667-0025

Endbell, 37-way

Order No.	Designation	Color
044-8597-000	Endbell for APD 37-way version only	black (RAL 9005)

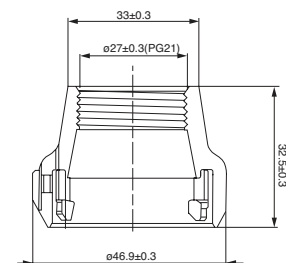

Dimensions shown in mm
Specifications and dimensions subject to change

Flange Gasket



Order Number: 075-8566-004

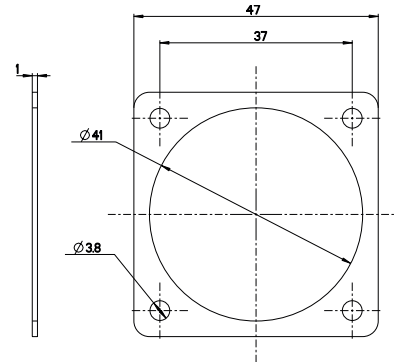

Dust Cap for Plug



Order Number: 025-8636-037

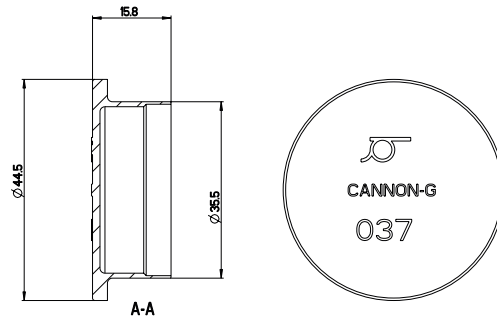

Dust Cap for Receptacle



Order Number: 025-8636-053

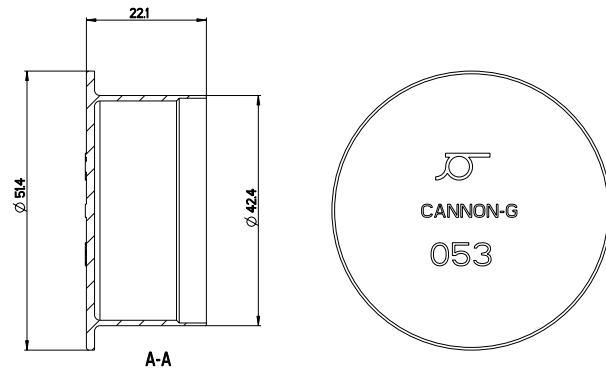

Alignment Disc 37-way

Alignment disc for 37-way Flange Receptacle

Order Number: 052-8509-004

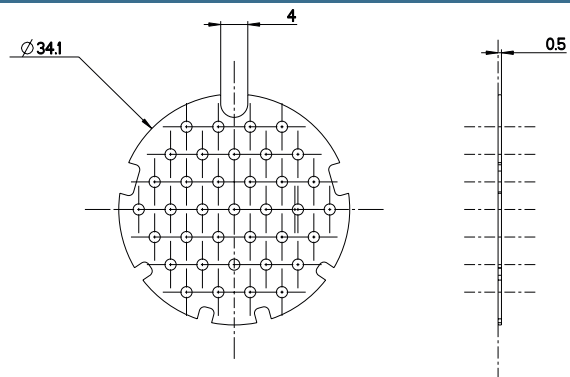

Hand Crimp Tool for Stamped and Formed Contacts



Contact	Hand Tool Order No.	Crimp Die
0,35 - 0,75 mm ²	121586-5156	121586-5260
0,75 - 1,5 mm ²	121586-5156	121586-5197

Mini Applicator for Stamped and Formed Contacts



Contact	Order No.	Designation
0,35 - 0,75 mm ²	121586-5131	WWZ-20-100-APK16-07-002
0,75 - 1,5 mm ²	121586-5132	WWZ-20-100-APK16-15-002

Support Tools, 37-way

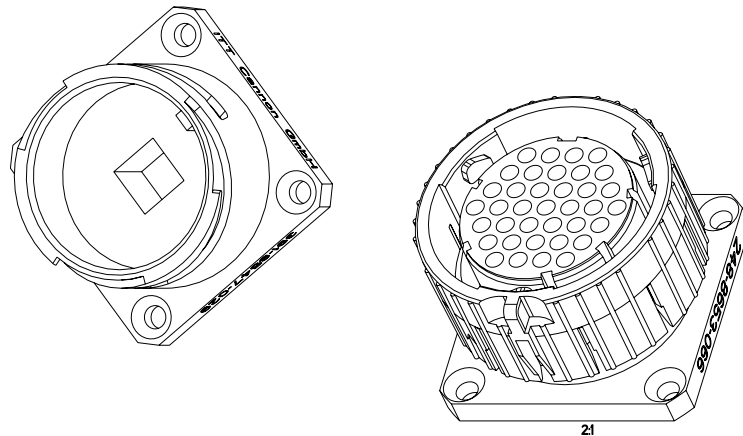

Designation	Order No.
Assembly Adaptor for plug MA-APD-37-R	391-8547-029
Assembly Adaptor for receptacle MA-APD-37-P	248-8653-066
Replacement Nut for MA-APD-37P	217-8516-007
Contact Insertion Tool CIT-APK-16-15-C	121586-5200
Contact Extraction Tool CET-APK-16-C	121586-5195

Hand Crimp Tool for Press-in Contacts



Basic Hand Crimp Tool No.	Order
M225201/1-01	995-0001-585

Locator No.	Order
M225201/1-05	995-0001-507

Automatic Crimp Tooling for Press-in Contacts



Designation	Order No.	Description
WAZ7F-CE	121586-5067	Pneumatic Tool
M22501/1-05	995-0001-507	Locator
BM-2	121586-5068	Bench Mount
WA-10	121586-5069	Food Pedal

Assembly Tooling for Press-in Contacts

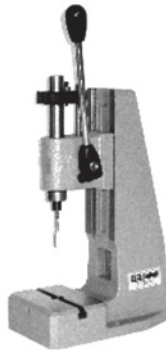

Designation	Order No.	Description
CHPZ-240	121586-0081	Hand Lever Press
CIT-APD16-TIP	317-8648-008	Mounting Tip



The APD 51-way connector offers the same features as the 37-way solution. Furthermore it is available in 2 versions, standard and secondary lock for added security. The connector features up to 8 mechanical key and visual color coding options for better mating identification and to avoid mis-mating.

Standard Code 1: Green
 Code 2: Yellow
 Code 3: Brown
 Code 4: Purple

For other coding consult factory

Electrical Data

Operating Voltage	48 VDC*
Operating Current	see derating curve
Contact Resistance	5 mΩ max.
Voltage Proof	1000 VAC, 60 seconds
Insulation Resistance	10 MΩ min.

Mechanical Data

Durability	40 Mating Cycles
Coupling Torque	4,5 Nm max.
Static Load, free connector	250 N axial, 150 N lat. (ISO 15170-2, Sec. 4.5)
Dynamic Impact	2 J (40mm- ball- drop- test, height 800mm)

Environmental Data (acc. ISO 15170)

Temperature Range	-40 °C up to 125 °C (ISO 15170-2, Sec. 6.4)
Humidity Range	up to 95 % r.h. (ISO 15170-2, Sec. 6.4)
Sealing	IP 67 + IP 69k (DIN EN 60529)
Salt Spray	96 h, 35 °C (ISO 15170-2, Sec. 6.2)
Industrial Climate	SO ₂ , 0,67 % (ISO 15170-2, Sec. 6.3)
Fluid Compatibility	Brakefluid, ATF, fuel, .. (ISO 15170-2, Sec. 6.6)*
Vibration Resistance	Random, 0,2(m/s ²)/Hz, 3 x 24h, RT

Materials List

Housing Parts	PBT GF
Sealing Parts	FKM
Coupling Nut	PA 6 GF
Contacts	Copper Alloy, Au or Sn plated*

*Further information on request

Derating Curve

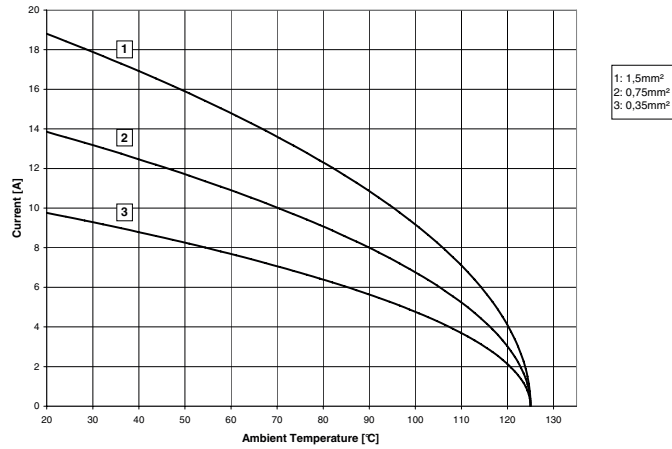

Plug, 51-way, Standard Version

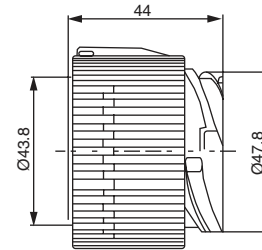
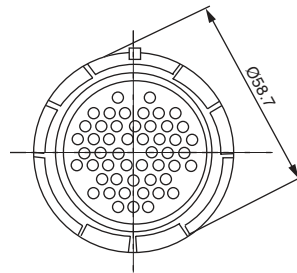

Order No.	Designation	Code	Color
121583-0032	APD-1BP51	1	green (RAL 6018)
121583-0033	APD-2BP51	2	yellow (RAL 1018)
121583-0030	APD-3BP51	3	brown (RAL 3009)
121583-0031	APD-4BP51	4	purple (RAL 4001)

Packaging unit 100 pcs.

Pin crimp contacts see page 69.

Accessories, see page 70.

Note: Standard version requires use of alignment disc.

Coding 51-way layout

View on Mating Face

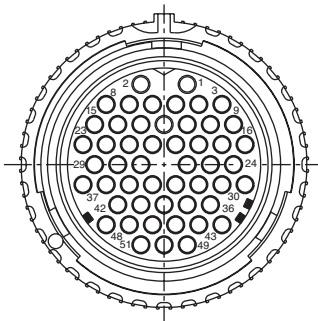

Code 1
green

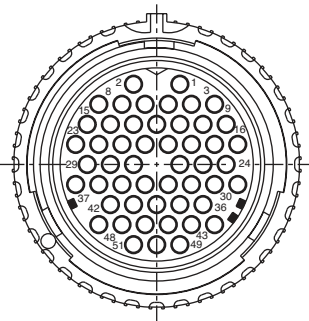

Code 2
yellow

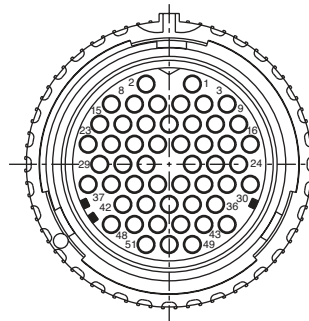

Code 3
brown

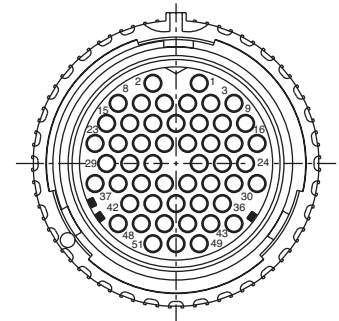

Code 4
purple

Note: The connectors offer both mechanical keying and visual coding by different colors.

Snap-In Receptacle, 51-way, Standard Version

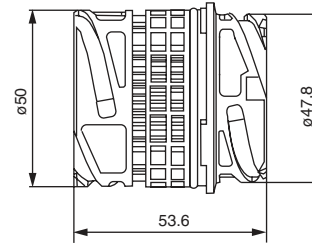
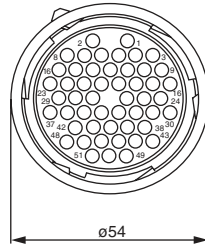

Order No.	Designation	Code	Color
249-8619-003	APD-1SS51	1	green (RAL 6018)
249-8619-004	APD-2SS51	2	yellow (RAL 1018)
249-8619-001	APD-3SS51	3	brown (RAL 3009)
249-8619-002	APD-4SS51	4	purple (RAL 4001)

Packaging unit 100 pcs.

Socket crimp contacts see page 69.
Accessories, see page 70.

Coding 51-way layout

View on Mating Face

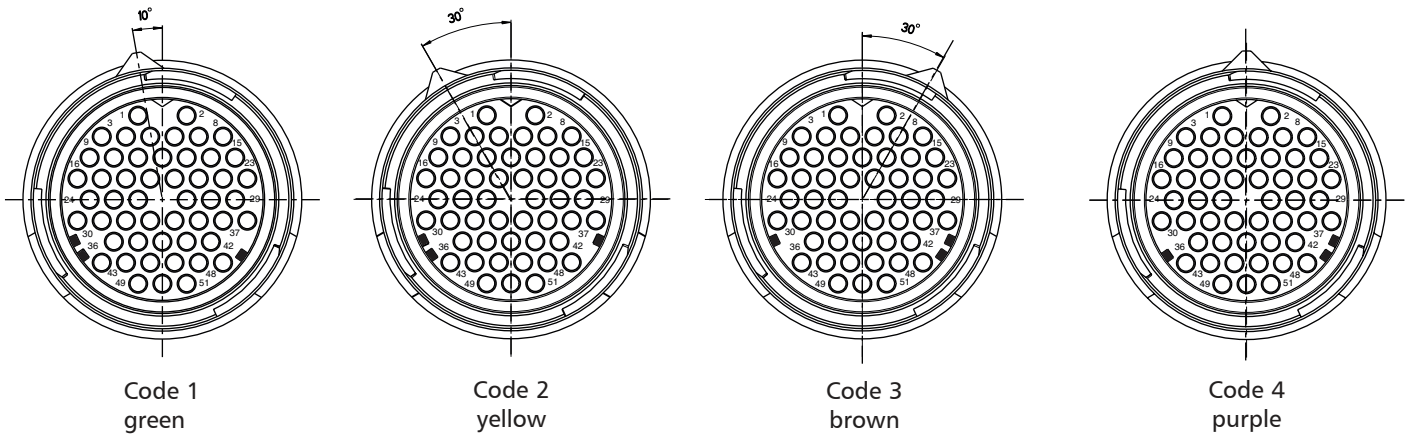

Note: The connectors offer both mechanical keying and visual coding by different colors.

3D data showing snap-in design available upon request.

Jam Nut Receptacle, 51-way, Standard Version



1

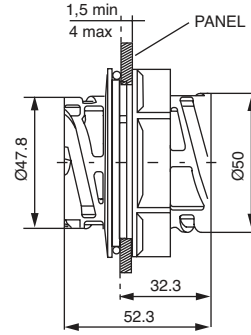
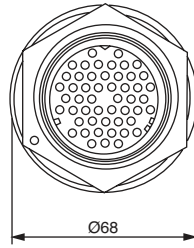

Order No.	Designation	Code	Color
121583-0081	APD-1CS51	1	green (RAL 6018)
121583-0082	APD-2CS51	2	yellow (RAL 1018)
121583-0079	APD-3CS51	3	brown (RAL 3009)
121583-0080	APD-4CS51	4	purple (RAL 4001)

Packaging unit 100 pcs.

Socket crimp contacts see page 69.

Accessories, see page 70.

Coding 51-way layout

View on Mating Face

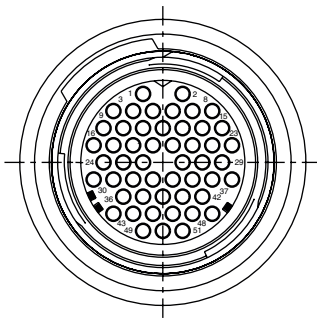

Code 1
green

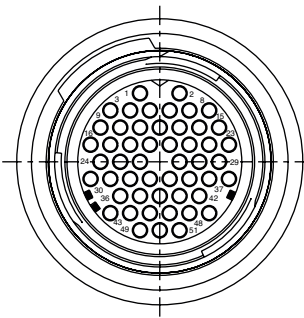

Code 2
yellow

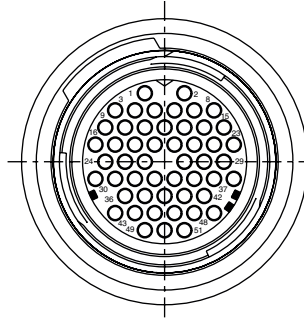

Code 3
brown

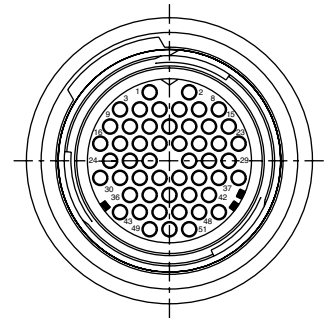

Code 4
purple

Note: The connectors offer both mechanical keying and visual coding by different colors.

Panel Cut Out

Piece Parts / Assembly Instruction

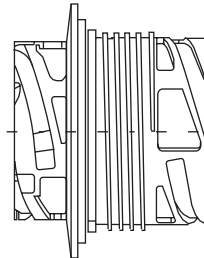
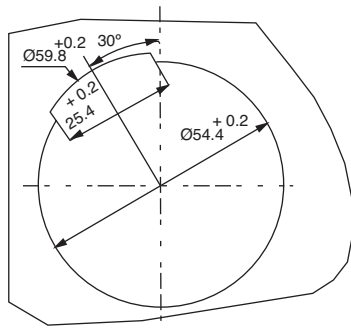

Housing



O-Ring



Jam Nut

Wall Thickness
Standard: min. 1,5 / max. 4,0 mm

Dimensions shown in mm
Specifications and dimensions subject to change



Plug, 51-way, Secondary Lock Version

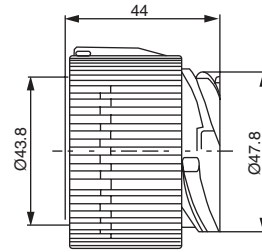
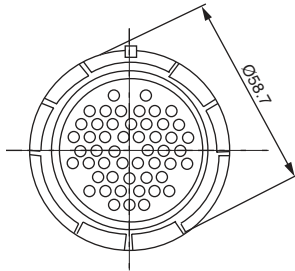

Order No.	Designation	Code	Color
121583-0187	APD-1BP51SN	1	green (RAL 6018)
121583-0188	APD-2BP51SN	2	yellow (RAL 1018)
121583-0189	APD-3BP51SN	3	brown (RAL 3009)
121583-0190	APD-4BP51SN	4	purple (RAL 4001)

Packaging unit 100 pcs.

Pin crimp contacts see page 69.
Accessories, see page 70.

Coding 51-way layout

View on Mating Face

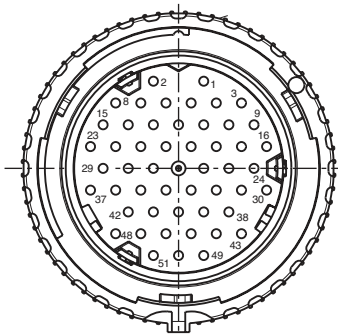

Code 1
green

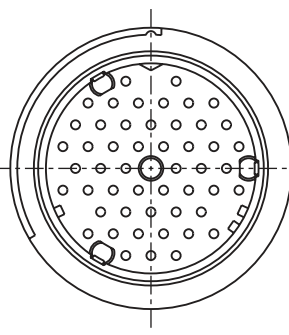

Code 2
yellow

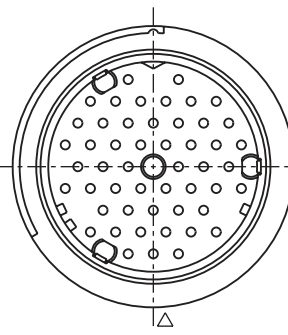

Code 3
brown

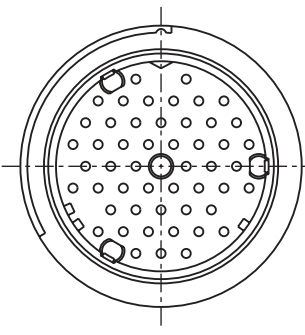

Code 4
purple

Note: The connectors offer both mechanical keying and visual coding by different colors.

Snap-In Receptacle, 51-way, Secondary Lock Version

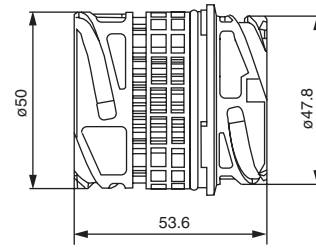
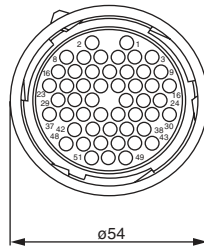

Order No.	Designation	Code	Color
121583-0091	APD-1SS51S	1	green (RAL 6018)
121583-0092	APD-2SS51S	2	yellow (RAL 1018)
121583-0093	APD-3SS51S	3	brown (RAL 3009)
121583-0094	APD-4SS51S	4	purple (RAL 4001)

Packaging unit 100 pcs.

Socket crimp contacts see page 69.
Accessories, see page 70.

Coding 51-way layout

View on Mating Face

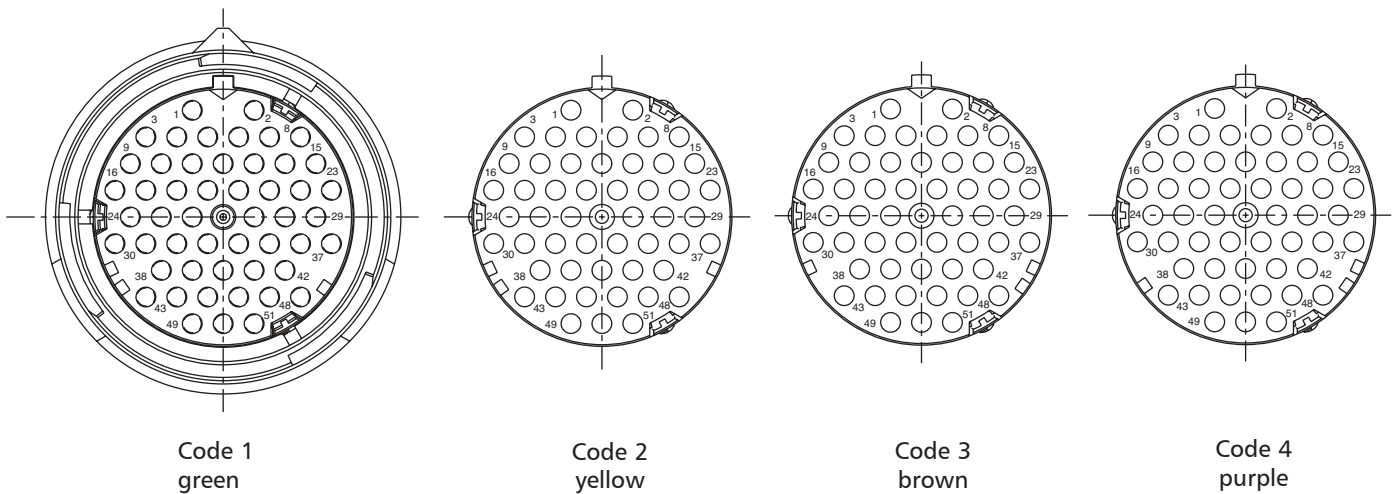

Note: The connectors offer both mechanical keying and visual coding by different colors.

Snap-In dimension on demand 3-D-image available.

Jam Nut Receptacle, 51-way, Secondary Lock Version

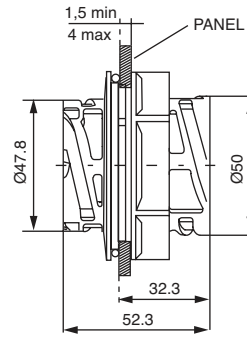
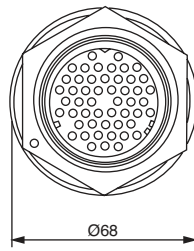

Order No.	Designation	Code	Color
121583-0095	APD-1CS51S	1	green (RAL 6018)
121583-0096	APD-2CS51S	2	yellow (RAL 1018)
121583-0097	APD-3CS51S	3	brown (RAL 3009)
121583-0098	APD-4CS51S	4	purple (RAL 4001)

Packaging unit 100 pcs.
 Socket crimp contacts see page 69.
 Accessories, see page 70.

Coding 51-way layout

View on Mating Face

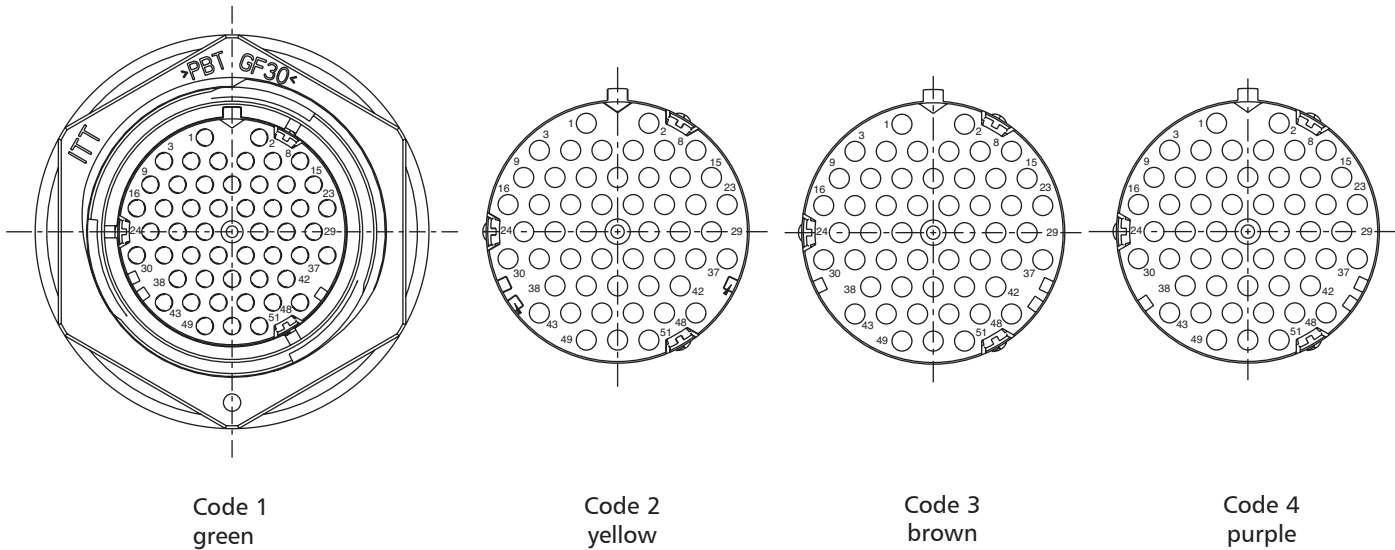

Note: The connectors offer both mechanical keying and visual coding by different colors.

Panel Cut Out

Piece Parts / Assembly Instruction

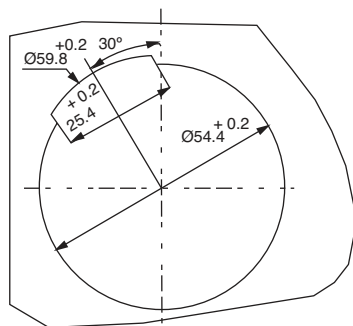

Wall Thickness
 Standard: min. 1,5 / max. 4,0 mm

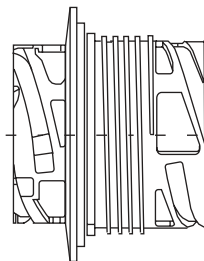

Housing



O-Ring

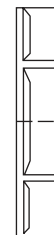

Jam Nut



Dimensions shown in mm
 Specifications and dimensions subject to change

CONTACTS



- Low contact resistance (max. 5mΩ) for maximum signal integrity
- Current carrying capacity: 12A max.
- Machined press-in contacts. (other machined contacts available on request)
- Silver plating, please consult factory

For 51-way Standard Version

Contacts (stamped & formed)	Plating	Crimp Range	Reeled (5000 pcs)		Loose Piece (bags of 100)	
			Designation	Part number	Designation	Part number
Socket contacts	tin	0,35 - 0,75 mm ²	APK-SA16A07-002-C	121668-0220	-	-
		0,75 - 1,5 mm ²	APK-SA16A15-002-C	121668-0222	-	-
	gold (0,8 μm)	0,35 - 0,75 mm ²	APK-SA16G07-002-C	121668-0266	-	-
		0,75 - 1,5 mm ²	APK-SA16G15-002-C	121668-0268	-	-
Pin contacts	tin	0,35 - 0,75 mm ²	APK-PA16A07-002-C	121668-0254	-	-
		0,75 - 1,5 mm ²	APK-PA16A15-002-C	121668-0255	-	-
	gold (0,8 μm)	0,35 - 0,75 mm ²	APK-PA16G07-002-C	121668-0265	-	-
		0,75 - 1,5 mm ²	APK-PA16G15-002-C	121668-0267	-	-

For 51-way Secondary Lock Version

Contacts (stamped & formed)	Plating	Crimp Range	Reeled (5000 pcs)		Loose Piece (bags of 100)	
			Designation	Part number	Designation	Part number
Socket contacts	tin	0,35 - 0,75 mm ²	APK-SA16A07-002	121668-0221	APK-SA16A07-002-B	121668-0274
		0,75 - 1,5 mm ²	APK-SA16A15-002	121668-0202	APK-SA16A15-002-B	121668-0276
	gold (0,8 μm)	0,35 - 0,75 mm ²	APK-SA16G07-002	121668-0270	APK-SA16G07-002-B	121668-0278
		0,75 - 1,5 mm ²	APK-SA16G15-002	121668-0272	APK-SA16G15-002-B	121668-0280
Pin contacts	tin	0,35 - 0,75 mm ²	APK-PA16A07-002	121668-0252	APK-PA16A07-002-B	121668-0275
		0,75 - 1,5 mm ²	APK-PA16A15-002	121668-0253	APK-PA16A15-002-B	121668-0277
	gold (0,8 μm)	0,35 - 0,75 mm ²	APK-PA16G07-002	121668-0269	APK-PA16G07-002-B	121668-0279
		0,75 - 1,5 mm ²	APK-PA16G15-002	121668-0271	APK-PA16G15-002-B	121668-0281

Press-In Contacts (Standard Version)

Contacts (machined)	Plating	Crimp Range	Reeled		Single piece	
			Designation	Part number	Designation	Part number
Pin contacts	tin	0,3 - 0,6 mm ²	-	-	APK-PA16A06-E	330-8674-020
		0,3 - 0,6 mm ²	-	-	APK-PA16G06-E	330-8674-026
	gold (0,8 μm)	0,5 - 1,0 mm ²	-	-	APK-PA16G10-E	330-8674-025
		1,0 - 1,5 mm ²	-	-	APK-PA16G15-E	330-8674-024

Individual Wire Seals / Blind Seals

Description	Insulation Diameter	Color	Part Number
Single Wire Sealing	1,2 - 1,6 mm	Red	121667-0024
	1,4 - 2,0 mm	Grey	121667-0022
	1,9 - 2,1 mm	Yellow	121667-0023
Blind Seal	1,4 - 2,0 mm	White	121667-0025

Dimensions shown in mm
 Specifications and dimensions subject to change



Endbell, 51-way

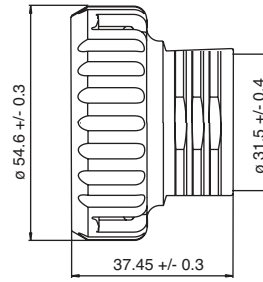

Order No.	Designation	Color
120110-0075	Endbell for APD 51-way version only	black (RAL 9005)

Packaging unit 100 pcs.

Alignment Disc, 51-way

Order No.	Designation
052-8509-003	Alignment disc for 51-way standard version only (plug only)

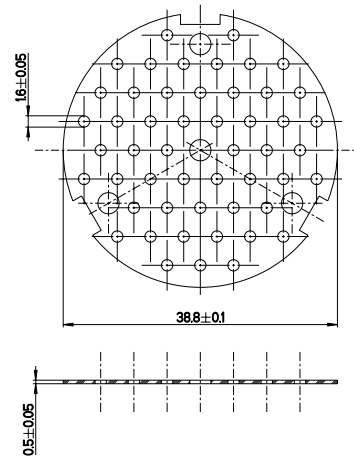

Note: Not required for secondary lock version.

Hand Crimp Tool for Stamped and Formed Contacts



Contact Locator	Hand Tool Order No.	
0,35 - 0,75 mm ²	121586-5156	121586-5260
0,75 - 1,5 mm ²	121586-5156	121586-5197

Mini Applications for Stamped and Formed Contacts

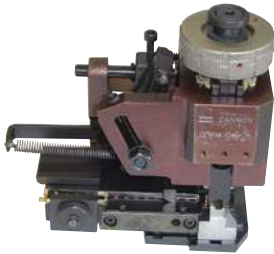

Contact	Order No.	Designation
0,35 - 0,75 mm ²	121586-5131	WWZ-20-100-APK16-07-002
0,75 - 1,5 mm ²	121586-5132	WWZ-20-100-APK16-15-002

Support Tools, 51-way

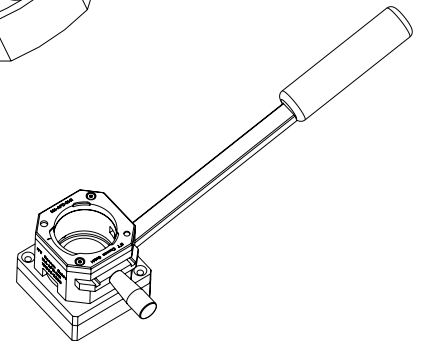
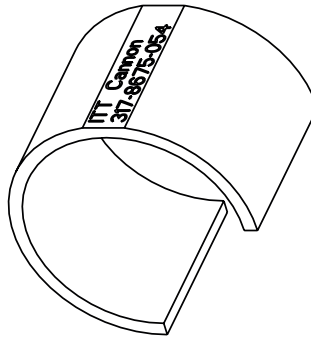
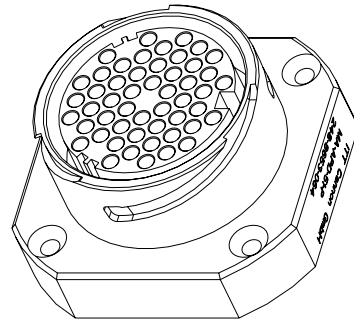
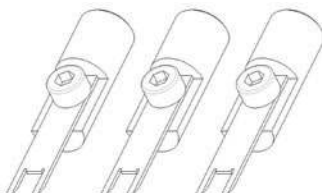
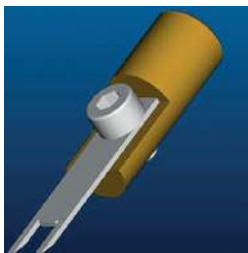

Designation	Order No.
Assembly Adaptor for plug MA-APD-51-P	248-8653-064
Assembly Adaptor for receptacle MA-APD-51-R	249-8619-011
Replacement Nut for MA-APD-51-R	217-8516-005
Assembly adaptor for plug MA-APD-51-P-SEC-LOCK	121586-5202
Assembly adaptor for receptacle MA-APD-51-R-SEC-LOCK	121586-5203
Assembly adaptor for Jam nut MA-APD-51-FL-SEC-LOCK	121586-5206
Unlocking Device	317-8675-054
Secondary Lock Set CET-ADP-51	121586-5259*

*For plug only

Dimensions shown in mm
Specifications and dimensions subject to change

Hand Crimp Tool for Press-in Contacts



Basic Hand Crimp Tool No.	Order
M225201/1-01	995-0001-585

Locator No.	Order
M225201/1-05	995-0001-507

Automatic Crimp Tooling for Press-in Contacts



Designation	Order No.	Description
WA27-7	121586-5067	Pneumatic Tool
M22501/1-05	995-0001-507	Locator
BM-2	121586-5068	Bench Mount
WA-10	121586-5069	Food Pedal

Assembly Tooling for Press-in Contacts

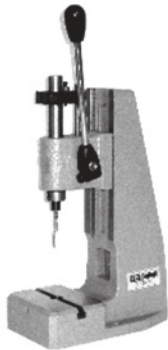

Designation	Order No.	Description
CHPZ-240	121586-0081	Hand Lever Press
CIT-APD16-TIP	317-8648-008	Mounting Tip

The demand within the transportation & industrial markets for direct PC board connections is increasing. Solutions demanding space savings, reduction of assembly costs or standardized assembly methods are just a selection of reasons driving this trend. PCB type connectors complement the offering of crimp and solder cup type connections within the APD product range.

APD connectors with PCB contacts can be offered for most of our products shown in this catalog. This chapter will provide a first impression of technical features and benefits as well as examples of PCB connector solution.



Technical Specifications

Mechanical Data:	All PCB connectors are derived from standard APD lines and feature similar properties
Electrical Data:	Depends on exact design of contacts and requirements of solution, generally similar to respective APD standard product
Environmental:	IP67 / IP69K with improved long term stability against fluids e.g. motor oil due to press-in assembly into connector. Resistance against fluids according to ISO 15170

Technical Specifications

- PCB contacts are useable in all non secondary lock versions
- Increased long term stability – sealing against e.g. motor oil
- Individual definition of contact length – adaptation to application
- Pre-assembled versions can be delivered - avoids additional harnessing work
- Useable for printed flex board applications
- Increases reliability (no harness errors)
- Avoids additional harness costs and reduces complexity of total manufacturing process

Cross Reference AWG Size / metric size (mm²)

AWG	mm ²	AWG	mm ²	AWG	mm ²
6/0	170,3	10	5,27	25	0,163
5/0	135,1	11	4,15	26	0,128
4/0	107,2	12	3,31	27	0,102
3/0	85,0	13	2,63	28	0,0804
2/0	67,5	14	2,08	29	0,0646
0	53,4	15	1,65	30	0,0503
1	42,4	16	1,31	31	0,0400
2	33,6	17	1,04	32	0,0320
3	26,7	18	0,823	33	0,0252
4	21,2	19	0,653	34	0,0200
5	16,8	20	0,519	35	0,0161
6	13,3	21	0,412	36	0,0123
7	10,6	22	0,325	37	0,0100
8	8,35	23	0,259	38	0,00795
9	6,62	24	0,205	39	0,00632

Conversion Chart for mm to Inches

mm	Inches	mm	inches	mm	Inches
1	0.04	18	0.71	35	1.38
2	0.08	19	0.75	36	1.42
3	0.12	20	0.79	37	1.46
4	0.16	21	0.83	38	1.50
5	0.20	22	0.87	39	1.54
6	0.24	23	0.91	40	1.57
7	0.28	24	0.94	41	1.61
8	0.31	25	0.98	42	1.65
9	0.35	26	1.02	43	1.69
10	0.39	27	1.06	44	1.73
11	0.43	28	1.10	45	1.77
12	0.47	29	1.14	46	1.81
13	0.51	30	1.18	47	1.85
14	0.55	31	1.22	48	1.89
15	0.59	32	1.26	49	1.93
16	0.63	33	1.30	50	1.97
17	0.67	34	1.34		

Equation for converting mm to inches:
mm divided by 25.4 = inches

Conversion Chart for Centigrade to Fahrenheit

°C	°F	°C	°F	°C	°F
-40	-40.0	-10	+14.0	+10	+50.0
-38	-36.4	-9	+15.8	+11	+51.8
-36	-32.8	-8	+17.6	+12	+53.6
-34	-29.2	-7	+19.4	+13	+55.4
-32	-25.6	-6	+21.2	+14	+57.2
-30	-22.0	-5	+23.0	+15	+59.0
-28	-18.4	-4	+24.8	+16	+60.8
-26	-14.8	-3	+26.6	+17	+62.6
-24	-11.2	-2	+28.4	+18	+64.4
-22	-7.6	-1	+30.2	+19	+66.2
-20	-4.0	0	+32.0	+20	+68.0
-19	-2.2	+1	+33.8	+21	+69.8
-18	+0.4	+2	+35.6	+22	+71.6
-17	+1.4	+3	+37.4	+23	+73.4
-16	+3.2	+4	+39.2	+24	+75.2
-15	+5.0	+5	+41.0	+25	+77.0
-14	+6.8	+6	+42.8	+26	+78.8
-13	+8.6	+7	+44.6	+27	+80.6
-12	+10.4	+8	+46.4	+29	+82.4
--11	+12.2	+9	+48.2	+29	+84.2
				+30	+86.0

Equation for converting Centigrade to Fahrenheit:
32 + (°C x 1.8) = Fahrenheit



Order Number	Page	Order Number	Page	Order Number	Page
025-0480-000	16, 23, 33, 40	120110-0220	14	121583-0095	68
025-0487-000	50	120110-0221	14	121583-0094	67
025-8636-005	16, 23, 33, 40	120110-0222	14	121583-0095	68
025-8636-037	59	120110-0229	14	121583-0096	68
025-8636-053	50, 59	120190-0163	41	121583-0097	68
030-8531-030	13	121086-3278	34	121583-0098	68
030-8531-031	13	121583-0000	26	121583-0119	45
030-8531-032	13	121583-0001	26	121583-0120	46
030-8531-033	13	121583-0002	26	121583-0121	45
030-8581-029	12	121583-0003	26	121583-0122	46
030-8614-010	12, 17	121583-0004	27	121583-0123	45
030-8614-020	12, 17	121583-0005	27	121583-0124	46
030-8614-030	12, 17	121583-0006	27	121583-0125	45
031-8521-010	12, 17	121583-0007	27	121583-0126	46
031-8521-020	12, 17	121583-0008	28	121583-0127	46
031-8521-030	12, 17	121583-0009	28	121583-0128	46
031-8531-010	13	121583-0010	28	121583-0129	46
031-8531-011	13	121583-0011	28	121583-0130	46
031-8531-012	13	121583-0012	8	121583-0131	46
031-8531-013	13	121583-0013	8	121583-0132	46
031-8646-001	22, 24	121583-0014	9	121583-0133	46
031-8646-002	22, 24	121583-0015	9	121583-0134	46
031-8646-003	22, 24	121583-0016	10	121583-0135	47
031-8646-010	22, 24	121583-0017	10	121583-0136	47
031-8646-011	22, 24	121583-0018	36	121583-0187	66
031-8646-015	12	121583-0019	37	121583-0188	66
044-8597-000	58	121583-0020	38	121583-0189	66
044-8597-002	50	121583-0021	15, 23, 33, 40	121583-0190	66
044-5897-004	50	121583-0025	19	121583-0205	38
052-5809-003	70	121583-0026	19	121583-0211	36
052-8509-004	59	121583-0027	20	121583-0212	38
058-8578-100	33, 40	121583-0028	37	121583-0213	30
058-8578-101	33, 40	121583-0030	63	121583-0214	30
058-8578-102	33, 40	121583-0031	63	121583-0215	31
058-8578-103	33, 40	121583-0032	63	121583-0216	31
058-8578-105	33, 40	121583-0033	63	121583-0217	10
066-8516-005	9, 19, 27, 31	121583-0042	8	121586-0081	41, 54, 61, 72
075-8503-000	15, 22, 32, 39	121583-0043	9	121586-5067	54, 61, 72
075-8503-004	15, 22, 32, 39	121583-0058	56	121586-5068	54, 61, 72
075-8566-003	51	121583-0061	37	121586-5069	54, 61, 72
075-8566-004	59	121583-0079	65	121586-5075	24
120090-0165	24	121583-0080	65	121586-5077	24
120090-0171	24	121583-0081	65	121586-5131	53, 60, 71
120110-0011	43	121583-0082	65	121586-5132	53, 60, 71
120110-0013	43	121583-0083	19	121586-5134	34
120110-0014	43	121583-0084	19	121586-5135	34
120110-0020	38	121583-0085	20	121586-5136	34
120110-0024	36	121583-0086	20	121586-5149	24
120110-0026	15, 23, 33, 40	121583-0091	67	121586-5156	53, 60, 71
120110-0075	70	121583-0092	67	121586-5192	17
120110-0083	38	121583-0093	67	121586-5193	17
120110-0217	16, 23, 33, 39	121583-0094	67	121586-5195	60

Order Number	Page	Order Number	Page	Order Number	Page
121586-5197	60	121668-0272	49, 69	351-8697-005	15
121586-5200	60	121668-0274	49, 69	351-8697-007	22
121586-5202	71	121668-0275	49, 69	351-8697-009	15
121586-5203	71	121668-0276	49, 69	351-8697-010	22
121586-5206	71	121668-0277	49, 69	351-8697-014	15
121586-5217	41	121668-0278	49, 69	430-8645-000	22, 24
121586-5229	17	121668-0279	49, 69	430-8645-002	22, 24
121586-5232	17	121668-0280	49, 69	430-8645-003	22, 24
121586-5234	53	121668-0281	49, 69	430-8645-007	22, 24
121586-5235	53	192900-0000	39	430-8645-009	22, 24
121586-5237	41	192900-0001	39	980-8672-004	15, 23
121586-5242	34	192900-0002	39	980-8672-005	17, 24
121586-5249	34	192900-0003	39	980-8672-010	15, 23
121586-5244	24	192922-1450	41	980-8672-015	52
121586-5253	17	192990-7600	41	980-8672-016	52
121586-5257	17	217-8516-001	10, 20, 28, 37	980-8672-017	52
121586-5259	71	217-8516-005	71	980-8672-018	52
121667-0022	39, 49, 58, 69	217-8516-007	60	980-8672-019	52
121667-0023	39, 49, 58, 69	249-8619-011	71	980-8672-020	52
121667-0024	39, 49, 58, 69	248-8653-026	57	980-8672-021	52
121667-0025	39, 49, 58, 69	248-8653-031	42	980-8672-034	51
121688-0021	32	248-8653-053	42	995-0001-507	54, 61, 72
121688-0025	32	248-8653-063	17, 24	995-0001-585	41, 54, 61, 72
121668-0022	32	248-8653-064	71		
121668-0026	32	248-8653-066	60		
121668-0027	32	248-8653-105	42		
121668-0028	32	248-8653-106	42		
121668-0029	32	248-8653-134	42		
121668-0032	32	249-8619-001	64		
121668-0033	32	249-8619-002	64		
121668-0034	32	249-8619-003	64		
121668-0035	22	249-8619-004	64		
121668-0124	32	249-8619-005	11		
121668-0125	32	249-8619-006	11		
121668-0126	32	249-8619-007	21		
121668-0127	32	249-8619-010	17, 24		
121688-0128	32	249-8619-017	57		
121688-0202	49, 69	317-8648-008	41, 54, 61, 72		
121668-0220	58, 65	317-8649-034	17, 24		
121668-0221	49, 69	317-8675-054	71		
121668-0222	58, 65	330-8672-019	37, 38		
121688-0252	49, 69	330-8672-021	37, 38		
121688-0253	49, 69	330-8674-020	58, 69		
121668-0254	58, 65	330-8674-024	69		
121668-0255	58, 65	330-8674-025	58, 69		
121668-0265	58, 65	330-8674-026	69		
121668-0266	58, 65	331-8547-029	60		
121668-0267	58, 65	351-8697-000	22		
121668-0268	58, 65	351-8697-001	15		
121668-0269	49, 69	351-8697-002	15		
121668-0270	49, 69	351-8697-003	15		
121668-0271	49, 69	351-8697-004	15		

Product Safety and Warranty

1. MATERIAL CONTENT AND PHYSICAL FORM
Electrical connectors do not usually contain hazardous materials.

Electrical connectors and individual components do not release or otherwise result in exposure to hazardous chemicals under normal conditions of use and fall under the definition of "Article," under the Hazard Communication Standard, 29 CFR 1910.1200, and are not considered hazardous materials.

Solder and fluxes can be hazardous if inhaled or absorbed through the skin and should only be used as recommended by the manufacturer. Please consult your solder and flux manufacturer for more specific application recommendations.

2. FIRE CHARACTERISTICS AND ELECTRIC SHOCK HAZARD

There is no fire hazard when the connector is correctly wired and used within the specified parameters. Incorrect wiring or assembly of the connector or careless use of metal tools or conductive fluids, or transit damage to any of the component parts may cause electric shock or burns. Live circuits must not be broken by separating mated connectors as this may cause arcing, ionization and burning. Heat dissipation is greater at maximum resistance in a circuit. Hot spots may occur when resistance is raised locally by damage, e.g. cracked or deformed contacts, broken strands of wire. Local overheating may also result from the use of the incorrect application tools or from poor quality soldering or slack screw terminals. Overheating may occur if the ratings in the product Data Sheet/Catalog are exceeded and can cause breakdown of insulation and hence electric shock. If heating is allowed to continue it intensifies by further increasing the local resistance through loss of temper of spring contacts, formation of oxide film on contacts and wires and leakage currents through carbonization of insulation and tracking paths. Fire can then result in the presence of combustible materials and this may release noxious fumes. Overheating may not be visually apparent. Burns may result from touching overheated components.

3. HANDLING

Care must be taken to avoid damage to any component parts of electrical connectors during installation and use. Although there are normally no sharp edges, care must be taken when handling certain components to avoid injury to fingers. Always wear safety glasses to avoid potential injury to eyes during cleaning, soldering, fiber preparation, etc.

Electrical connectors may be damaged in transit to the customers, and damage may result in creation of hazards. Products should

therefore be examined prior to installation/use and rejected if found to be damaged. Proper lifting techniques shall be used for handling shipping cartons.

4. DISPOSAL

Please recycle, reclaim or dispose of connectors and individual components in accordance with local, state and federal laws. Incineration of certain materials may release noxious or even toxic fumes..

5. APPLICATION

Connectors with exposed contacts should not be selected for use on the current supply side of an electrical circuit, because an electric shock could result from touching exposed contacts on an unmated connector. Voltages in excess of 30 V ac or 42.5 V dc are potentially hazardous and care should be taken to ensure that such voltages cannot be transmitted in any way to exposed metal parts of the connector body. The connector and wiring should be checked, before making live, to have no damage to metal parts or insulators, no solder blobs, loose strands, conducting lubricants, swarf, or any other undesired conducting particles. Circuit resistance and continuity check should be made to make certain that there are no high resistance joints or spurious conducting paths. Always use the specified application tools, cleaning materials and assembly instructions documented in the Data Sheet/Catalog. Do not permit untrained personnel to wire, assemble or tamper with connectors. For operation voltage please see appropriate national regulations.

IMPORTANT GENERAL INFORMATION

(i) Air and creepage paths/Operating voltage.
The admissible operating voltages depend on the individual applications and the valid national and other applicable safety regulations.

For this reason the air and creepage path data are only reference values. Observe reduction of air and creepage paths due to PC board and/or harnessing.

(ii) Temperature

All information given are temperature limits. The operation temperature depends on the individual application.

(iii) Pressure

All pressure information given are differential pressure limits. The specific differential pressure limits, across the connector interface, are documented in the Data Safety/catalog

(iv) Other important information

Cannon continuously endeavors to improve

their products. Therefore, Cannon products may deviate from the description, technical data and shape as shown in this catalog and data sheets.

Commodities in this catalog may be controlled for export or re-export under the Export Administration Regulations (EAR), Nuclear Regulatory Commission (NRC) Regulations, or by the International Traffic in Arms Regulations (ITAR) when specifically designed, modified or configured for military use.

ITT Corporation Interconnect Solutions Division, ("ITT") manufactures high quality products. However, these products are intended to be used in accordance with the specifications in this publication. Any use or application that deviates from the stated operating specifications is not recommended and may be unsafe. No information and data contained in this publication shall be construed to create any liability on the part of ITT.

Product Warranty

A limited product warranty applies to ITT products. Please refer to www.ittcannon.com (General Terms and Conditions of Sale) for the complete text of ITT's applicable Terms and Conditions of Sale, including warranty.

This publication is not to be construed as an offer. It is intended merely as an invitation to make an offer. ITT does not assume liability for any patent infringement or violation of other rights claimed by third parties which may result from its use.

With prior written consent, reprinting this publication without any modifications is generally permitted.

"ITT", the Engineered Blocks Logo and "Engineered for life" are registered trademarks of ITT Corporation. All other trademarks or registered trademarks are property of their respective owners. All dates subject to change without notice.





ITT





Global Design & Manufacturing and Customer Support



North America

 **MEXICO - Cannon, VEAM**
Av. Libre Comercio s/n-
entre Calzada Industrial
Nuevo Nogales y Calzada
del Raquet Club,
Parque Industrial Nuevo Nogales
phone: +52.631.3110050
fax: +52.631.3110060

  **USA - Cannon**
56 Technology Drive
Irvine, CA 92618
toll free: +1.800.854.3028

Europe & Middle East



  **GERMANY - Cannon, VEAM**
Cannonstrasse 1
Weinstadt, 71384
phone: +49.7151.699.0
fax: +49.7151.699.217

  **ITALY - VEAM**
Corso Europa 41/43
Lainate (MI), Italy 20020
phone: +39.02938721
fax: +39.0293872300

Asia

  **CHINA - Cannon, VEAM**
Tuopandun Industrial Area, Jinda Cheng,
Xiner Village, Shajing Town,
Baoan District, Shenzhen City,
Guangdong, China 518125
phone: +86.755.2726.7238
fax: +86.755.2726.7515

 **HONG KONG - Cannon, VEAM**
Units 2405-6, 24/F, ING Tower
308 Des Voeux Road
Central
Hong Kong
phone: +852.2732.2720
fax: +852.2732.2919

  **JAPAN - Cannon, VEAM**
11-3, 5 Chome, Hibarigaoka, Zama-shi
Kanagawa, Japan 228-0003
phone: +81.462.57.2010
fax: +81.462.57.1680

www.ittcannon.com

© 2022 ITT Inc.
ITT Cannon APD Catalog 052022

© 2022 ITT Inc. "Engineered for life" and "Cannon" are registered trademarks of ITT Inc.
Specification and other data are based on information available at the time of printing,
and are subject to change without notice.