

DIMENSIONAL CHART FOR MULTIBAY CONFIGURATION:

PART NUMBER (TUBE PKG)	PART NUMBER (TRAY PKG)	BAY A			BAY B			BAY C			BAY D			DIM 'A'	DIM 'B'	DIM 'C'	DIM 'D'	DIM 'E'	DIM 'F'
		CKT	TYPE	POL	CKT	TYPE	POL	CKT	TYPE	POL	CKT	TYPE	POL						
34707-9000	34707-4000	20	0.64mm	A	20	0.64mm	B	20	0.64mm	C	20	0.64mm	D	132.74	130.27	27.94	27.94	27.94	27.94
TBD	34707-4010	12	0.64mm	A	20	0.64mm	A	8	0.64mm	A	16	0.64mm	A	102.26	99.79	17.78	27.94	12.70	22.86
TBD	34707-4020	20	0.64mm	D	20	0.64mm	C	20	0.64mm	B	20	0.64mm	A	132.74	130.27	27.94	27.94	27.94	27.94

4 BAY STAC64 VERTICAL HEADER ASSEMBLY
(P/N: 34707-4000 SHOWN)

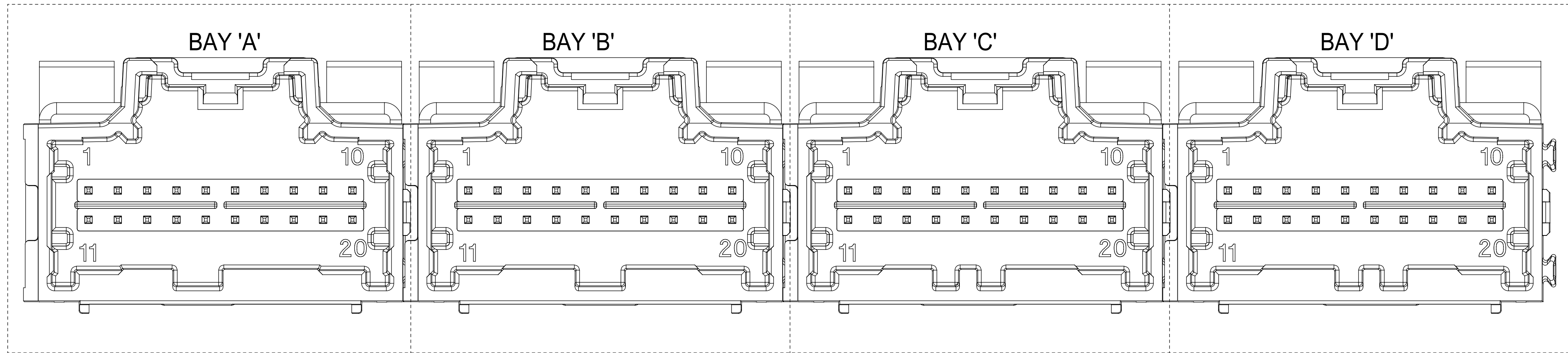

NOTES: VALID UNLESS OTHERWISE SPECIFIED
1. GENERAL:

a. CONNECTOR HEADER MUST BE VALIDATED TO THE FOLLOWING FUNCTIONAL REQUIREMENTS:

PRODUCT SPECIFICATION:
8-20 CKT 0.64mm PRODUCT SPEC: PS-34729-020/PS-31408-100
10/14 CKT HYBRID PRODUCT SPEC: PS-31372-100

b. APPLICATION REQUIREMENTS (REFERENCE ONLY):

APPLICATION SPECIFICATION: AS-34729-020/AS-31408-100

c. PACKAGING SPECIFICATION PER MOLEX DRAWING PK-31300-892 (TRAY)
d. PACKAGING SPECIFICATION PER MOLEX DRAWING PK-31301-063 (TUBE)

2. DESIGN: MATERIALS:

a. SHROUD (PLASTIC HOUSING):
RESIN - SPS 30%GF

b. 0.64mm PINS:
BASE MATERIAL: C26000
PLATING TYPE: AS NOTED

1.50/2.80mm BLADES:
BASE MATERIAL: C19400
PLATING TYPE: AS NOTED

3. PLATING REQUIREMENTS:

a. UNDERPLATING - OVERALL NICKEL

b. OVERPLATING - OVERALL TIN

4. FOR DESCRIPTION OF INDIVIDUAL BAYS, REFER TO THE FOLLOWING
SINGLE BAY DRAWINGS:
8-20 CKT 0.64: SD-34690-100
10 CKT HYBRID: SD-34695-100
14 CKT HYBRID: SD-34772-200

SYMBOLS	THIS DRAWING CONTAINS INFORMATION THAT IS PROPRIETARY TO MOLEX ELECTRONIC TECHNOLOGIES, LLC AND SHOULD NOT BE USED WITHOUT WRITTEN PERMISSION		CURRENT REV DESC:		
	DIMENSION UNITS	SCALE			
▽ = 0	mm	4:1			4-BAY STAC64 VERTICAL HEADER ASSEMBLY SALES DRAWING PRODUCT CUSTOMER DRAWING
▽ = 0	GENERAL TOLERANCES (UNLESS SPECIFIED)				
▽ = 0	ANGULAR TOL ± 3.0°		EC NO: 612618		DOCUMENT NUMBER SD-34707-400
▽ = 0	4 PLACES ±		DRWN: SHANDITHAVAL 2019/02/22		
▽ = 0	3 PLACES ±		CHK'D: RBAUMAN 2019/02/23		DOC TYPE DOC PART REVISION PSD 001 D9
▽ = 0	2 PLACES ± 0.13		APPR: RBAUMAN 2019/02/23		
▽ = 0	1 PLACE ± 0.25		INITIAL REVISION:		MATERIAL NUMBER CUSTOMER SHEET NUMBER SEE TABLE GENERAL MARKET 1 OF 4
▽ = 0	0 PLACES ±		DRWN: VDANIELE 2008/11/14		
▽ = 0	DRAFT WHERE APPLICABLE MUST REMAIN WITHIN DIMENSIONS		APPR: SMARCEAU 2008/11/14		
▽ = 0	THIRD ANGLE PROJECTION		DRAWING SERIES		
▽ = 0	D-SIZE		34707		

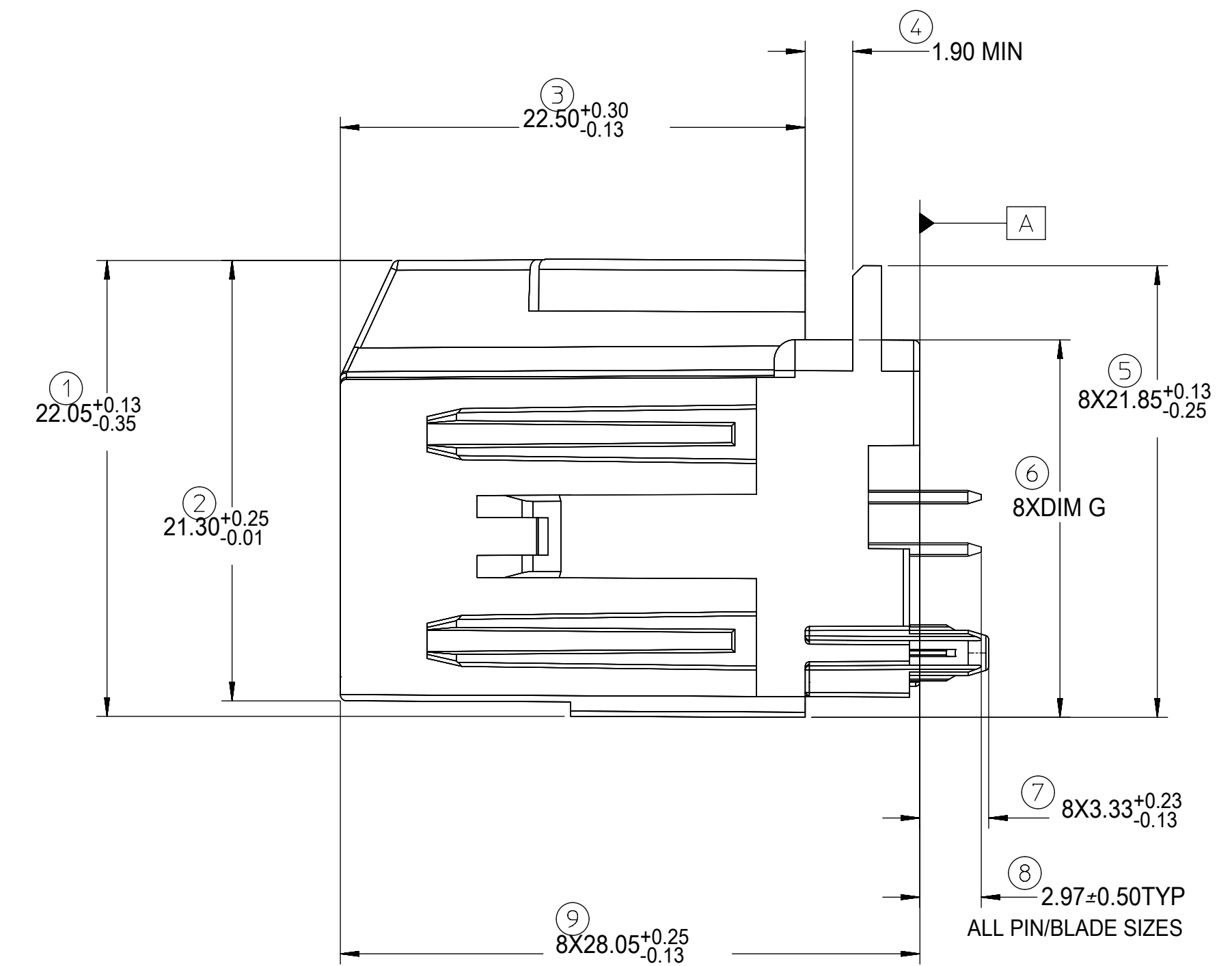
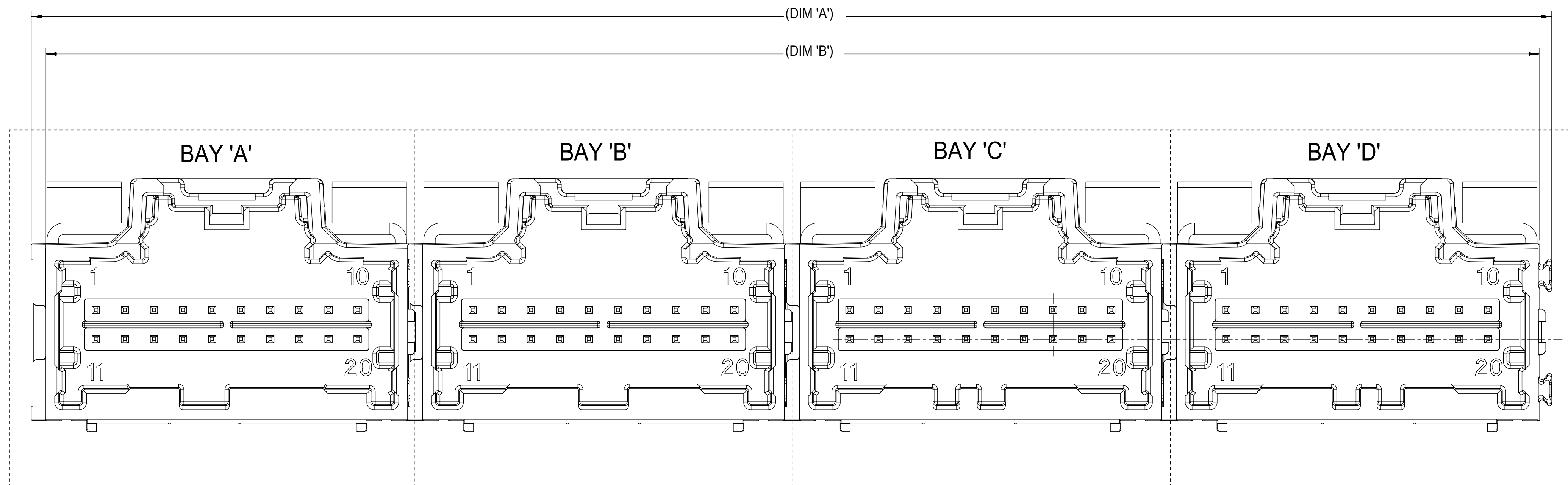

FOR DIM G:	
8-20CKT 0.64mm	18.40 MAX
10/14CKT Hybrid	18.59 MAX

RECOMMENDED PCB LAYOUT
INSERT NECESSARY BAY'S USING THE CHART ON SHEET 1

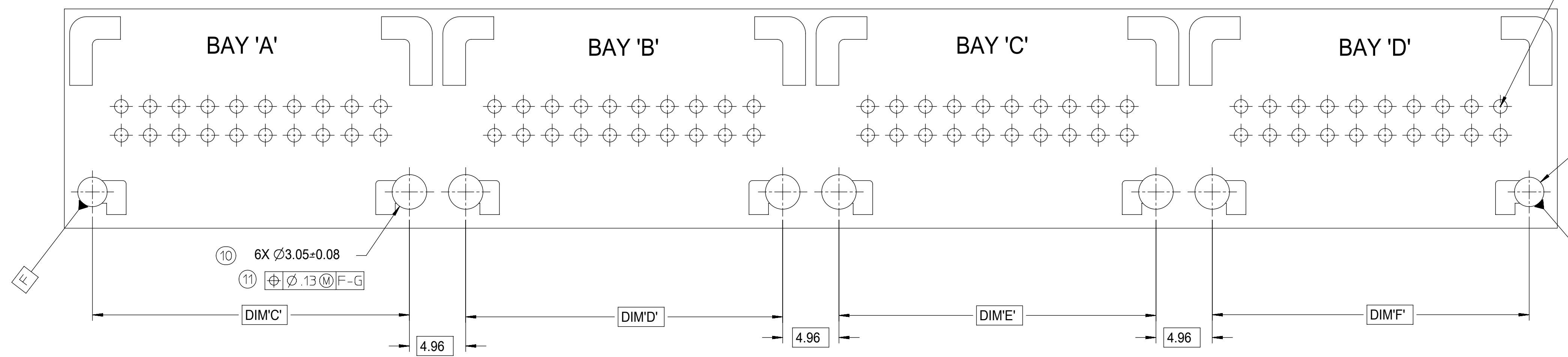

FOR HOLE LOCATION REFER TO TEMPLATES ON SHEET 4

2X $\varnothing Z \pm 0.08$ (12)
 $\varnothing .13$ (13)
 POST HOLE TABLE

FOR DIM Z:	
PRESS FIT	2.60
DROP IN	3.05

SYMBOLS	THIS DRAWING CONTAINS INFORMATION THAT IS PROPRIETARY TO MOLEX ELECTRONIC TECHNOLOGIES, LLC AND SHOULD NOT BE USED WITHOUT WRITTEN PERMISSION		CURRENT REV DESC:		molex			
DIMENSION UNITS	SCALE	EC NO:	612618					
$\nabla = 0$	mm	4:1	DRWN: SHANDITHAVAL	2019/02/22	4-BAY STAC64 VERTICAL HEADER ASSEMBLY SALES DRAWING			
$\nabla = 0$	GENERAL TOLERANCES (UNLESS SPECIFIED)		CHK'D: RBAUMAN	2019/02/23				
$\nabla = 0$	ANGULAR TOL $\pm 3.0^\circ$		APPR: RBAUMAN	2019/02/23	PRODUCT CUSTOMER DRAWING			
$\nabla = 0$	4 PLACES \pm		INITIAL REVISION:					
$\nabla = 0$	3 PLACES \pm		DRWN: VDANIELE		DOCUMENT NUMBER			
$\nabla = 0$	2 PLACES ± 0.13		2008/11/14				SD-34707-400	
$\nabla = 0$	1 PLACE ± 0.25		2008/11/14		DOC TYPE	DOC PART		REVISION
$\nabla = 0$	0 PLACES \pm		APPR: SMARCEAU		PSD	001	D9	
$\square = 0$	DRAFT WHERE APPLICABLE MUST REMAIN WITHIN DIMENSIONS		THIRD ANGLE PROJECTION	DRAWING	SERIES	MATERIAL NUMBER	CUSTOMER	SHEET NUMBER
$\nabla = 0$				D-SIZE	34707	SEE TABLE	GENERAL MARKET	2 OF 4

14KCT STAC HYBRID HEADER DETAILS

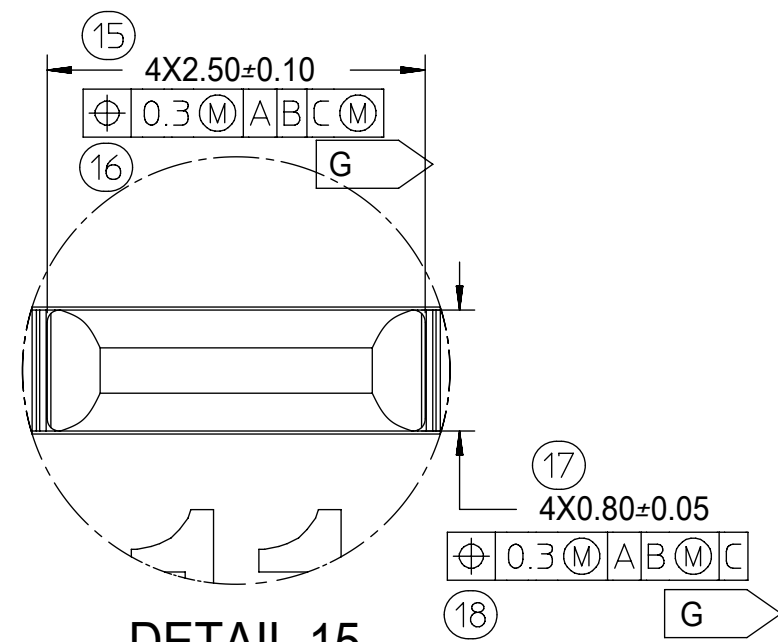
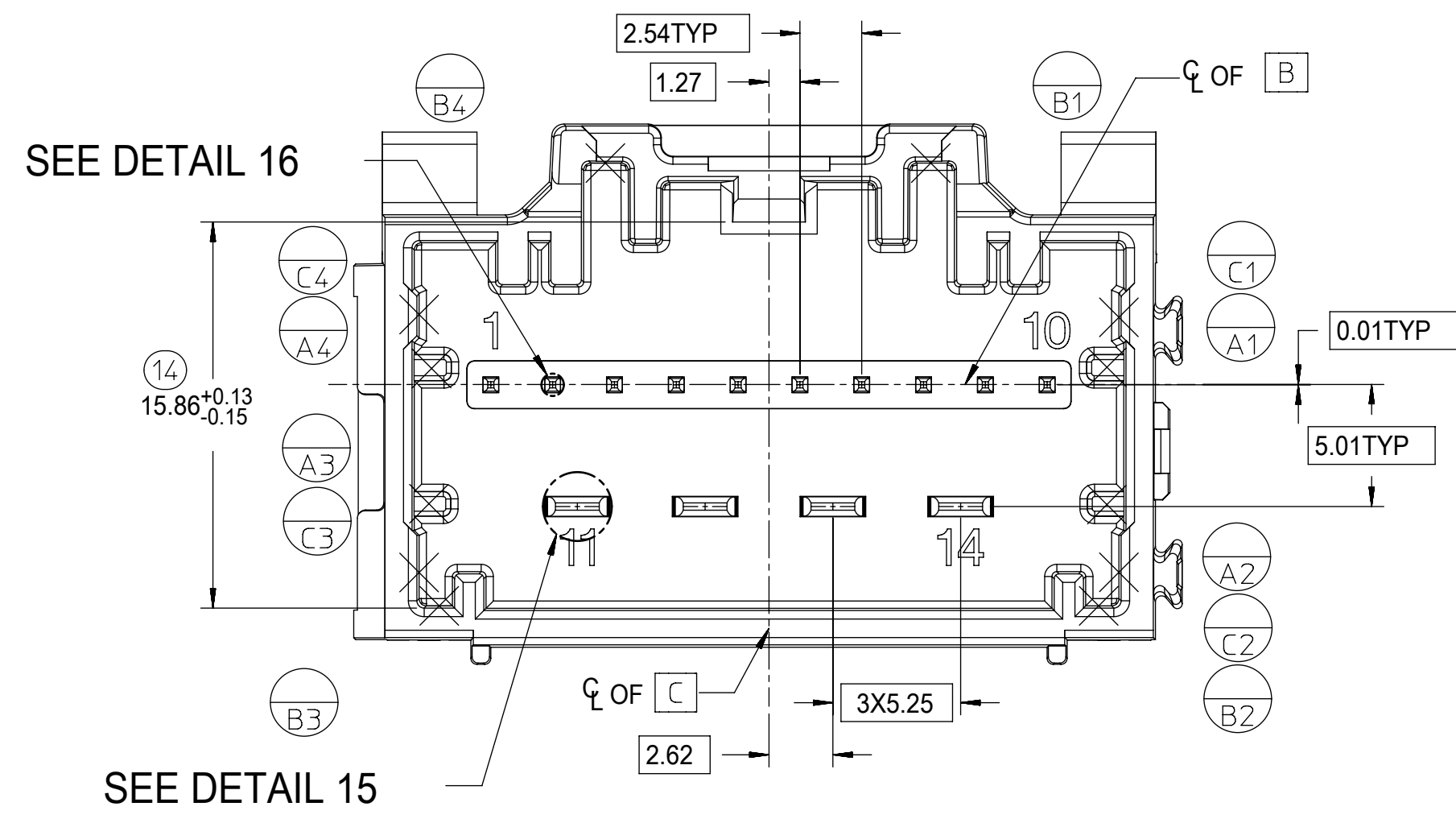

DETAIL 15
SCALE 20:1

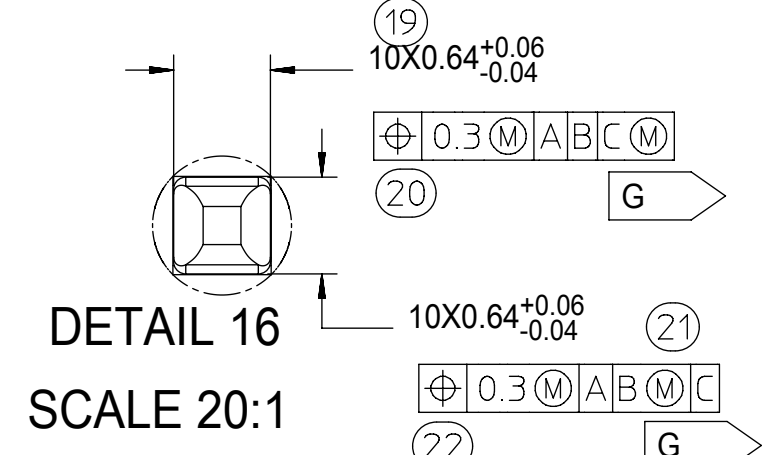

DETAIL 16
SCALE 20:1

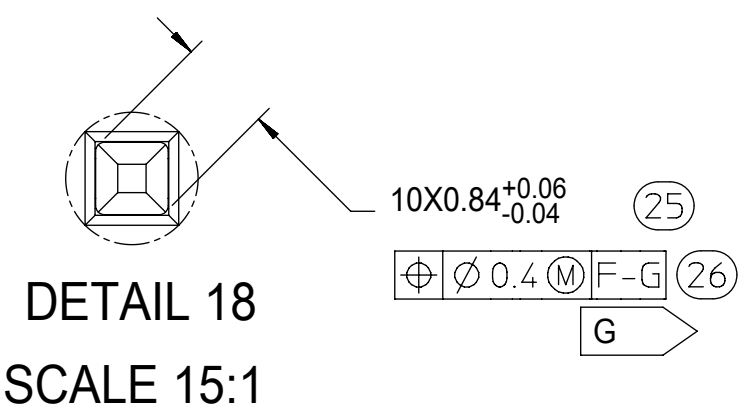
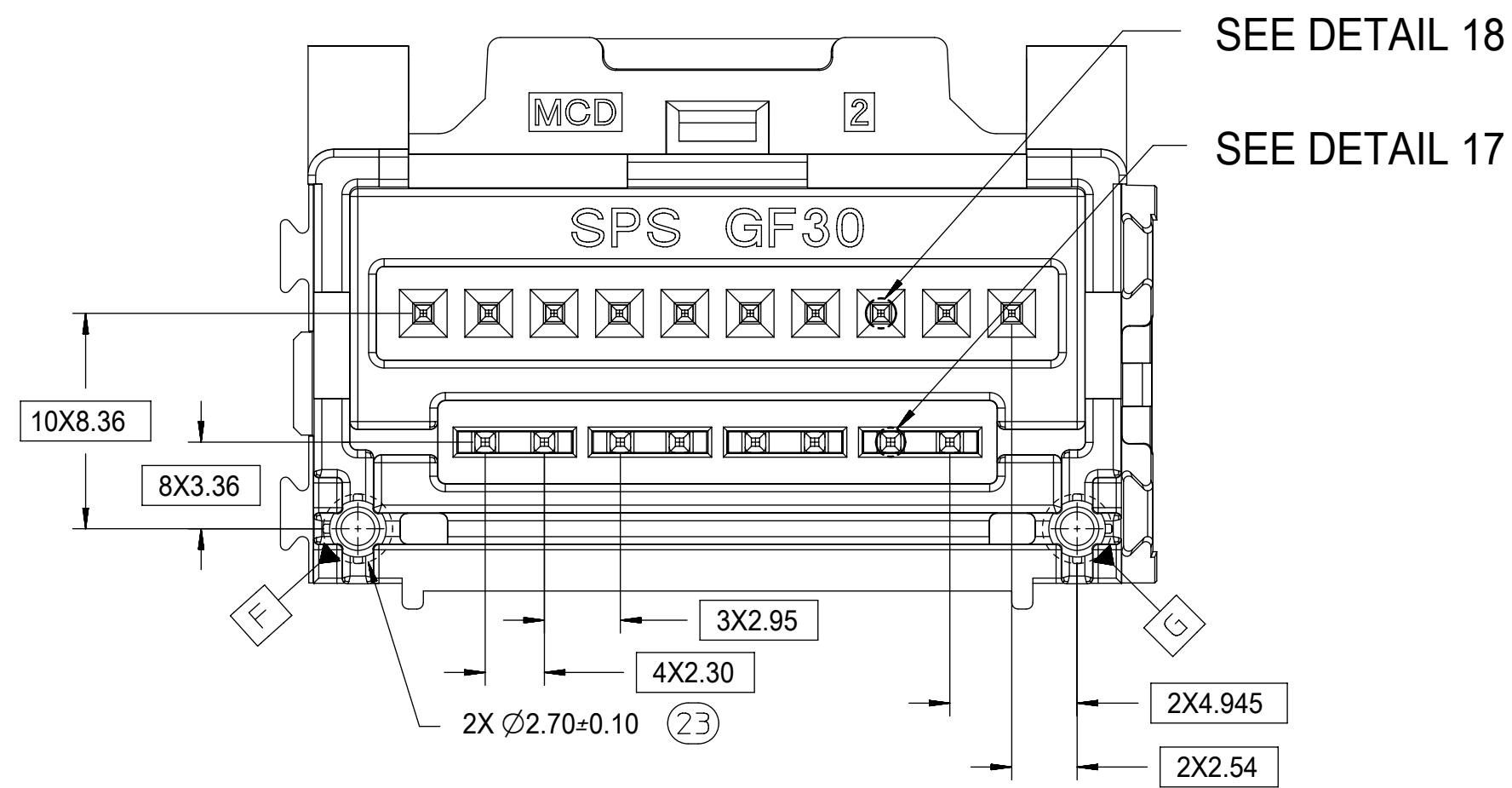

DETAIL 18
SCALE 15:1

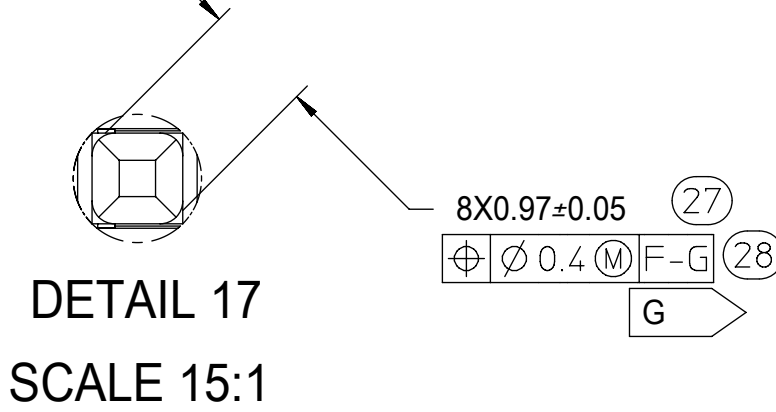

DETAIL 17
SCALE 15:1

8-20KCT STAC 0.64mm HEADER DETAILS

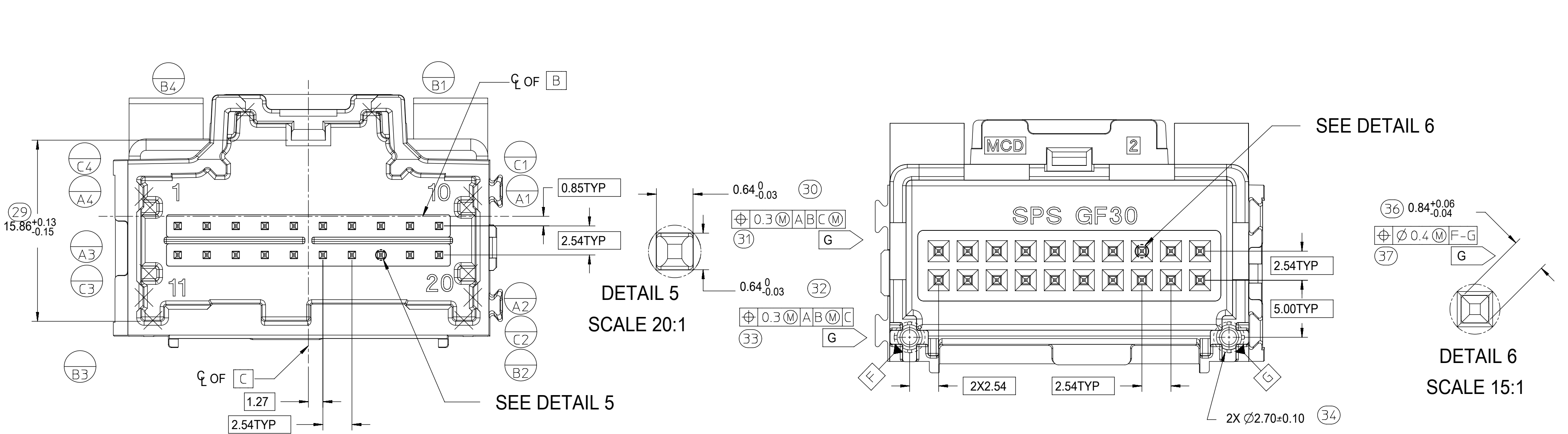

DETAIL 5
SCALE 20:1

DETAIL 6
SCALE 15:1

10KCT STAC HYBRID HEADER DETAILS

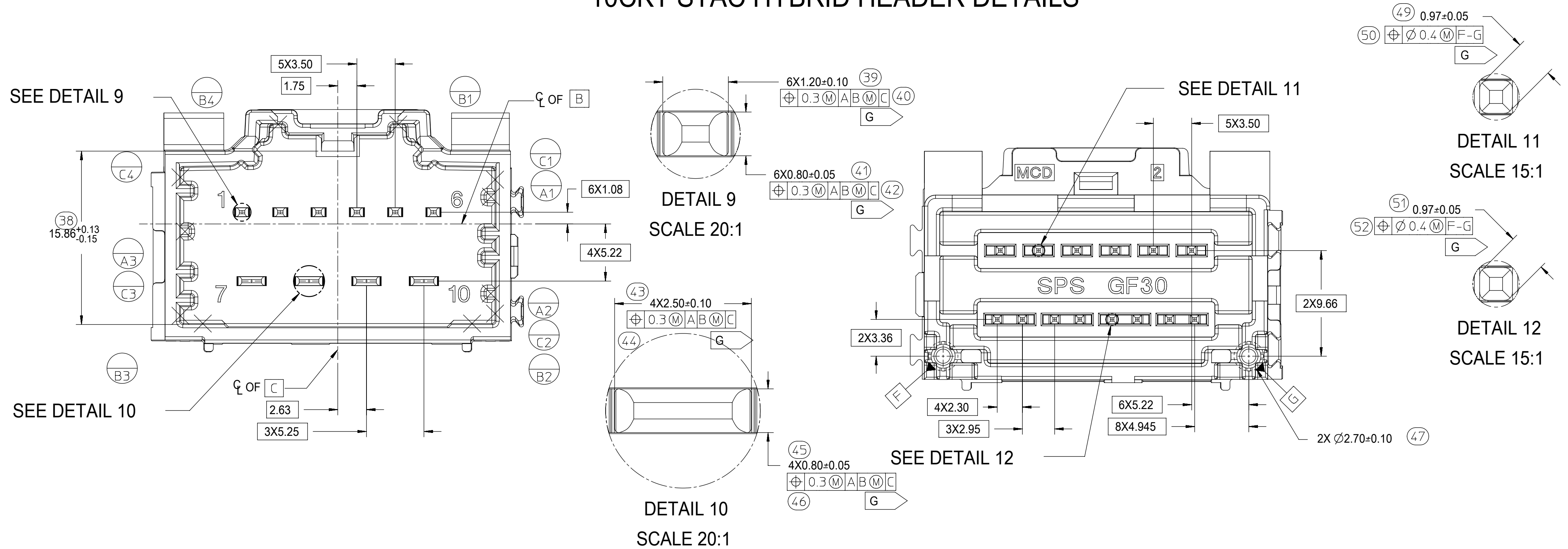

DETAIL 9
SCALE 20:1

DETAIL 11
SCALE 15:1

DETAIL 10
SCALE 20:1

DETAIL 12
SCALE 15:1

SYMBOLS	THIS DRAWING CONTAINS INFORMATION THAT IS PROPRIETARY TO MOLEX ELECTRONIC TECHNOLOGIES, LLC AND SHOULD NOT BE USED WITHOUT WRITTEN PERMISSION		CURRENT REV DESC:		
	DIMENSION UNITS	SCALE			
▽ = 0	mm	4:1			4-BAY STAC64 VERTICAL HEADER ASSEMBLY SALES DRAWING
▽ = 0	GENERAL TOLERANCES (UNLESS SPECIFIED)				
▽ = 0	ANGULAR TOL ± 3.0°		EC NO: 612618		PRODUCT CUSTOMER DRAWING
▽ = 0	4 PLACES ±		DRWN: SHANDITHAVAL 2019/02/22		
▽ = 0	3 PLACES ±		CHK'D: RBAUMAN 2019/02/23		DOCUMENT NUMBER SD-34707-400
▽ = 0	2 PLACES ± 0.13		APPR: RBAUMAN 2019/02/23		
▽ = 0	1 PLACE ± 0.25		INITIAL REVISION:		DOC TYPE DOC PART REVISION PSD 001 D9
▽ = 0	0 PLACES ±		DRWN: VDANIELE 2008/11/14		
▽ = 0	DRAFT WHERE APPLICABLE MUST REMAIN WITHIN DIMENSIONS		APPR: SMARCEAU 2008/11/14		MATERIAL NUMBER CUSTOMER SEE TABLE GENERAL MARKET
▽ = 0	THIRD ANGLE PROJECTION		DRAWING SERIES D-SIZE 34707		
			SHEET NUMBER 3 OF 4		

10 CKT HYBRID TEMPLATE
PCB LAYOUT

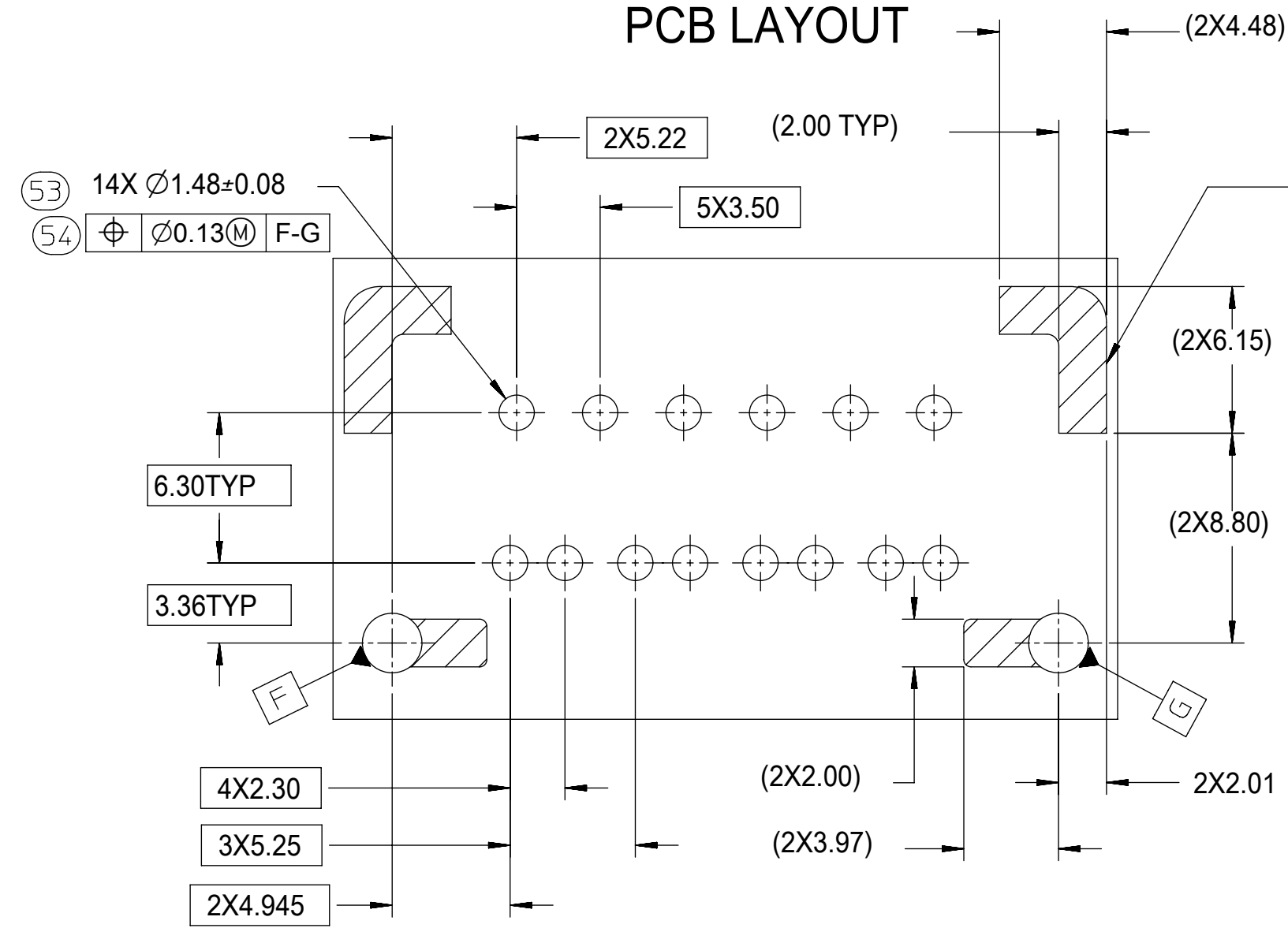

8-20 CKT 0.64mm TEMPLATE
PCB LAYOUT

HEADER TO PCB
CONTACT REGIONS
(8 PLACES)

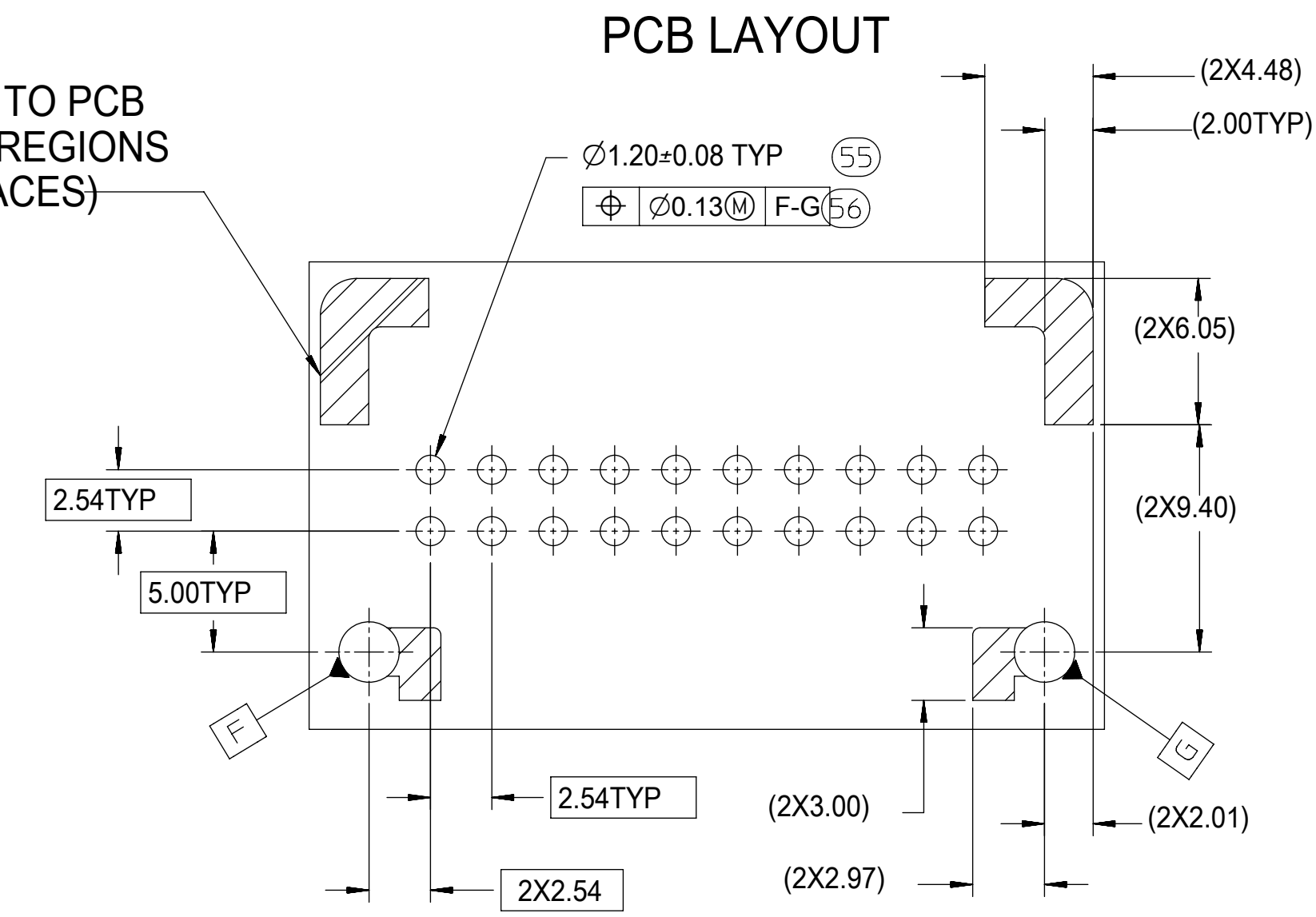

14 CKT HYBRID TEMPLATE
PCB LAYOUT

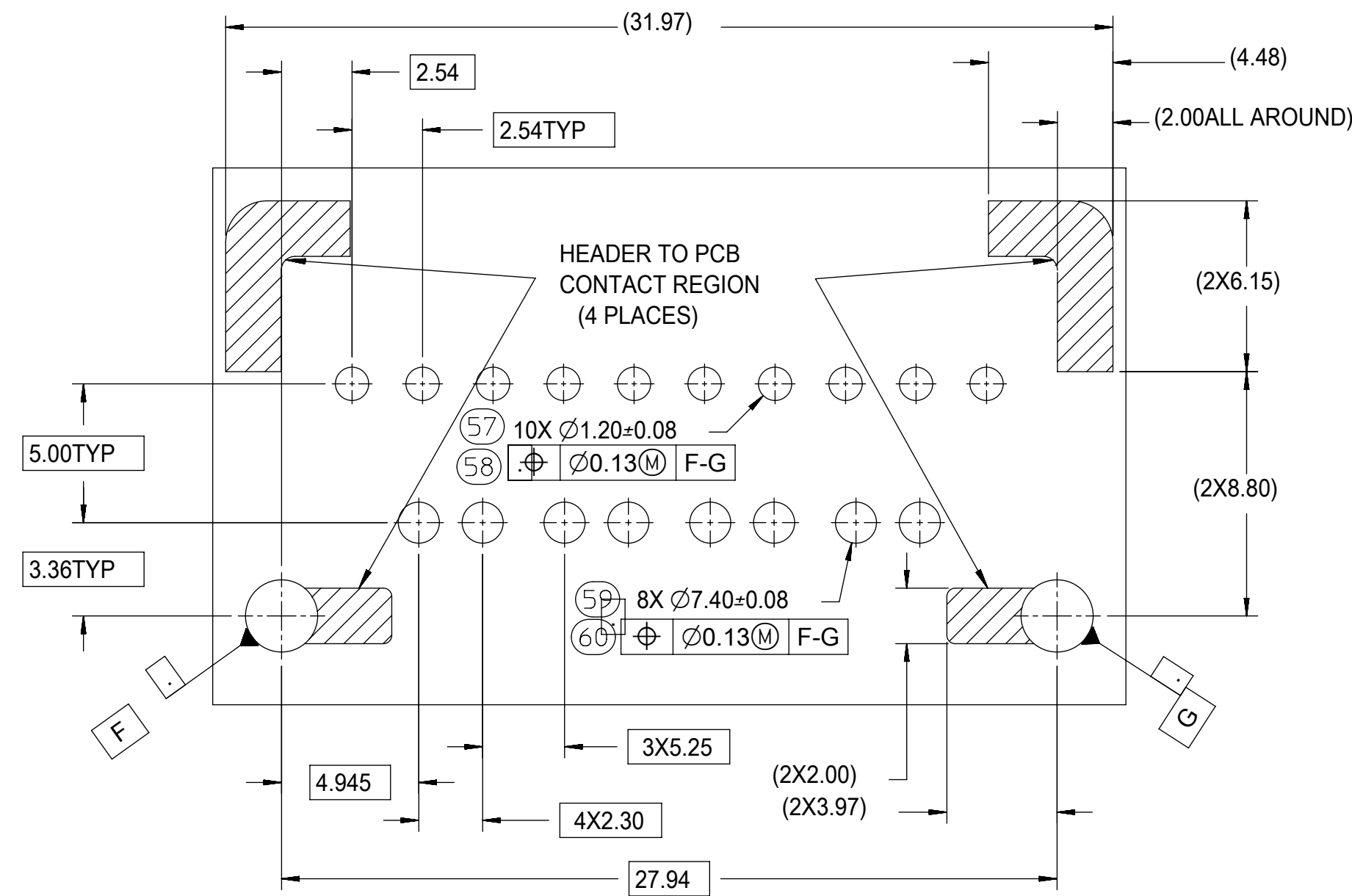

SYMBOLS	THIS DRAWING CONTAINS INFORMATION THAT IS PROPRIETARY TO MOLEX ELECTRONIC TECHNOLOGIES, LLC AND SHOULD NOT BE USED WITHOUT WRITTEN PERMISSION		
	DIMENSION UNITS	SCALE	CURRENT REV DESC:
$\nabla = 0$	mm	4:1	EC NO: 612618 DRWN: SHANDITHAVAL 2019/02/22 CHK'D: RBAUMAN 2019/02/23 APPR: RBAUMAN 2019/02/23 INITIAL REVISION: DRWN: VDANIELE 2008/11/14 APPR: SMARCEAU 2008/11/14
$\nabla = 0$	GENERAL TOLERANCES (UNLESS SPECIFIED)		
$\nabla = 0$	ANGULAR TOL $\pm 3.0^\circ$		
$\nabla = 0$	4 PLACES \pm		
$\nabla = 0$	3 PLACES \pm		
$\nabla = 0$	2 PLACES ± 0.13		PRODUCT CUSTOMER DRAWING DOCUMENT NUMBER: SD-34707-400 DOC TYPE: PSD DOC PART: 001 REVISION: D9
$\nabla = 0$	1 PLACE ± 0.25		
$\nabla = 0$	0 PLACES \pm		MATERIAL NUMBER: SEE TABLE CUSTOMER: GENERAL MARKET SHEET NUMBER: 4 OF 4
$\nabla = 0$	DRAFT WHERE APPLICABLE MUST REMAIN WITHIN DIMENSIONS		
$\nabla = 0$	THIRD ANGLE PROJECTION	DRAWING	SERIES
$\nabla = 0$		D-SIZE	34707