

RECOMMENDED MOUNTING HOLE PATTERN FOR 1.57 [.062] THICK P.C. BOARD

- 1 PARTS COMPLY TO AMP SOLDERABILITY SPECIFICATION 109-11-3.
- 2 CONTACT IS PLATED OVERALL WITH 0.00127 [.000050] NICKEL, THEN 0.00076 [.000030] GOLD OVER CONTACT LENGTH INDICATED AND MATTE TIN LEAD ON SOLDER TAIL END.
- 3 CIRCUIT IDENTIFICATION CHARACTERS ARE ADJACENT TO THE INDICATED CAVITIES, BUT LOCATION AND ORIENTATION MAY DIFFER FROM PRINT.
- 4 DIMENSIONS IN BRACKETS ARE IN INCHES.
- 5 CONTACT IS PLATED OVERALL WITH 0.00127 [.000050] NICKEL, THEN 0.00076 [.000030] GOLD OVER CONTACT LENGTH INDICATED AND MATTE TIN ON SOLDER TAIL END.
- 6 SUPERSEDED BY 350825-4
- 7 DIMENSION SHOWN REPRESENT PRODUCT IN DRY CONDITION. ADDITIONAL 2% GROWTH DUE TO END USE LOCATION MOISTURE ABSORPTION MAY OCCUR AND SHOULD BE ACCOUNTED FOR.

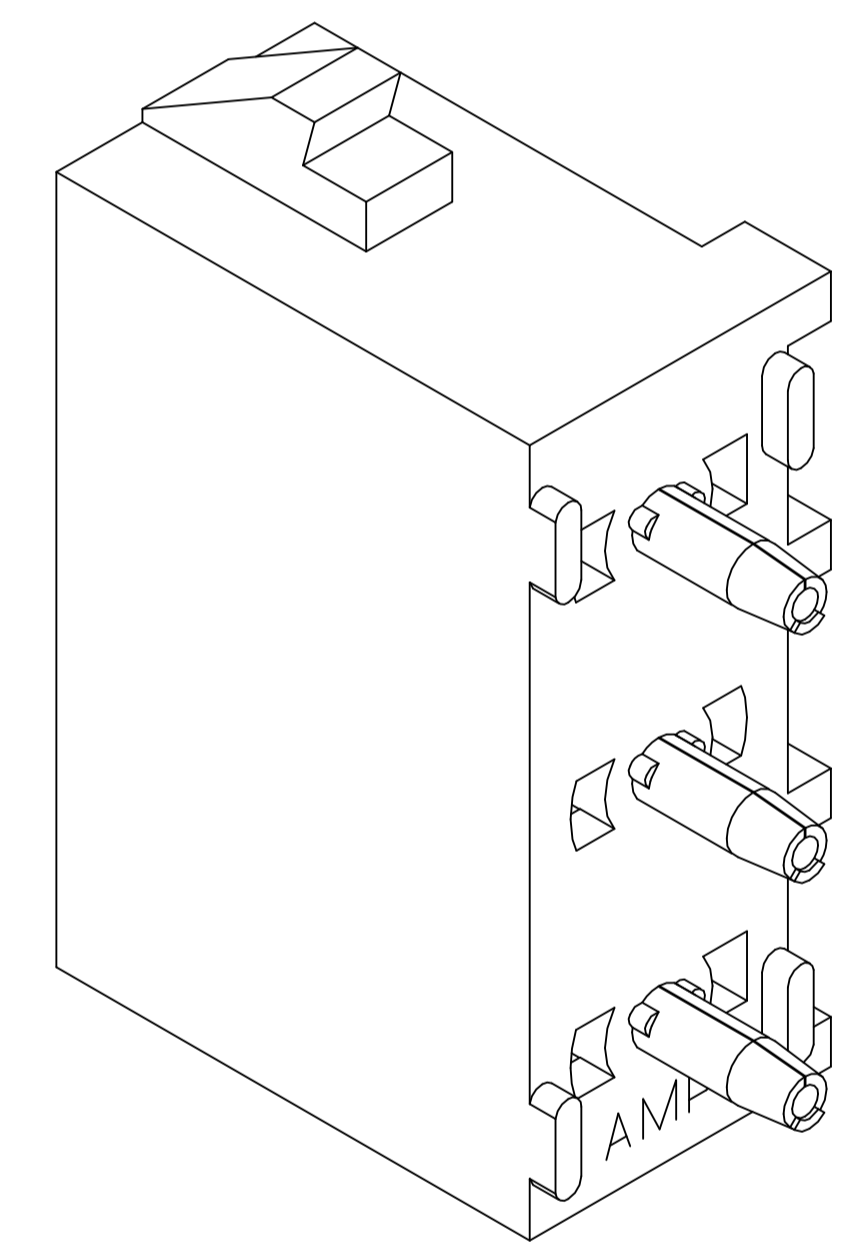

3-DIMENSIONAL MODEL NTS

PHOSPHOR BRONZE, GOLD	NYLON,UL94V-0,WHITE	350825-4
PHOSPHOR BRONZE, GOLD	NYLON,UL94V-0,WHITE	350825-2
PHOSPHOR BRONZE, PRE-TIN	NYLON,UL94V-0,WHITE	350825-1
CONTACT MATERIAL AND FINISH	HOUSING MATERIAL	PART NUMBER

THIS DRAWING IS A CONTROLLED DOCUMENT.		DIN 8-19-98	TE Connectivity	
DIMENSIONS: mm [INCHES]		0 PLC ± -	SOCKET HEADER ASSEMBLY, 3 CIRCUIT UNIVERSAL MATE-N-LOK™	
TOLERANCES UNLESS OTHERWISE SPECIFIED:		1 PLC ± -	SIZE: A1	
0 PLC ± -		2 PLC ± 0.13 [.005]	CAGE CODE: 00779	
1 PLC ± -		3 PLC ± -	DRAWING NO: 350825	
2 PLC ± -		4 PLC ± -	SCALE: 5:1	
3 PLC ± -		ANGLES ± 0°30'	SHEET 1 OF 1	
4 PLC ± -		FINISH SEE TABLE	REV N3	
MATERIAL SEE TABLE		WEIGHT -	CUSTOMER DRAWING	