

ISL9205xEVAL1Z

Evaluation Board Application\Manual

AN1375
Rev 1.00
October 22, 2008

The ISL9205xEVAL1Z is an evaluation tool for the ISL9205 single-cell Li-ion battery charger. The evaluation tool provides a complete evaluation platform addressing all data sheet specifications and functionality. The jumpers on the board facilitate the programming of the charge current and different charging conditions. They can also be used to make other necessary connections, such as current measurement.

The ISL9205 is a fully integrated single-cell Li-ion battery charger that accepts input voltages ranging from up to 6.5V. After being powered up, the ISL9205 is capable of operating at an input voltage as low as 2.5V. The low operating voltage allows the charger to work with a variety of AC adapters.

The ISL9205 offers both a 3 package and pinout option and a total of 5 functional variants. The evaluation board accommodates all of these variants. The board provides the pads for 2 package types: the 16 Ld package and the 10 Ld package. On the 10 Ld package option, there are 2 pin functions for pin 9; temperature function (TEMP) and the remote voltage sensing (VSEN) function. Two 0Ω resistors are used to select these functions. Please refer to the ordering information table to order the evaluation board.

Ordering Information

PART NUMBER	DESCRIPTION
ISL9205EVAL1Z	Evaluation Board for ISL9205
ISL9205AEVAL1Z	Evaluation Board for ISL9205A
ISL9205BEVAL1Z	Evaluation Board for ISL9205B
ISL9205CEVAL1Z	Evaluation Board for ISL9205C
ISL9205DEVAL1Z	Evaluation Board for ISL9205D

Key Features

- A Complete Evaluation Platform for the ISL9205 Charger
- Accommodates All Package Options
- Accepts Input Voltage up to 6.5V
- Flexible Power Connectors each with a Hook and a Solder Pad Providing Variety to Users
- Convenient Jumpers for Programming the Charge Current, Charge Mode and for Current Measurement
- 89mmx65mm Board Size Handy for Evaluation
- Six Thermal Vias in the Thermal Pad Similar To Customers' Thermally Enhanced Environment
- On-Board LEDs for Input $\overline{\text{FAULT}}$ and $\overline{\text{STATUS}}$ State Indication

What is Needed

The following instruments will be needed to perform testing:

- Power supplies:
 - PS1: DC 30V/5A
 - PS2: DC 20V/5A
- DC Electronic load: 20V/5A
- Multimeters
- Function generator
- Oscilloscope
- Cables and wires

Quick Setup Guide (Refer to Figure 1)

DO NOT APPLY POWER UNTIL STEP 8

- Step 1:* Connect a 5V supply PS1 to J1 with the current limit set at 1.2A
- Step 2:* Insert a jumper shunt between pins 2 and 3 of J2, as shown in Figure 1
- Step 3:* Connect a 3.7V supply PS2 to J2 as shown in Figure 1, with the current limit set at 1.2A
- Step 4:* Connect the DC electronic load of 1.2A to J2
- Step 5:* Connect amp-meter I2 as shown in Figure 1
- Step 6:* Insert a thermistor (type 103ET), or a 10k resistor on JP2 to set a valid temperature window
- Step 7:* Switch off all bits of the DIP switch except Bit 9
- Step 8:* Turn on Power Supplies and DC electronic load
- Step 9:* The green LED should be on, indicating normal charging operation
- Step 10:* The current meter I2 in series with PS2 should read about 90mA as the charging current
- Step 11:* Switch on Bit 5 of the DIP switch, the current meter I2 should read about 800mA
- Step 12:* Switch on both Bit 5 and Bit 6; the current meter I2 should read about 1000mA

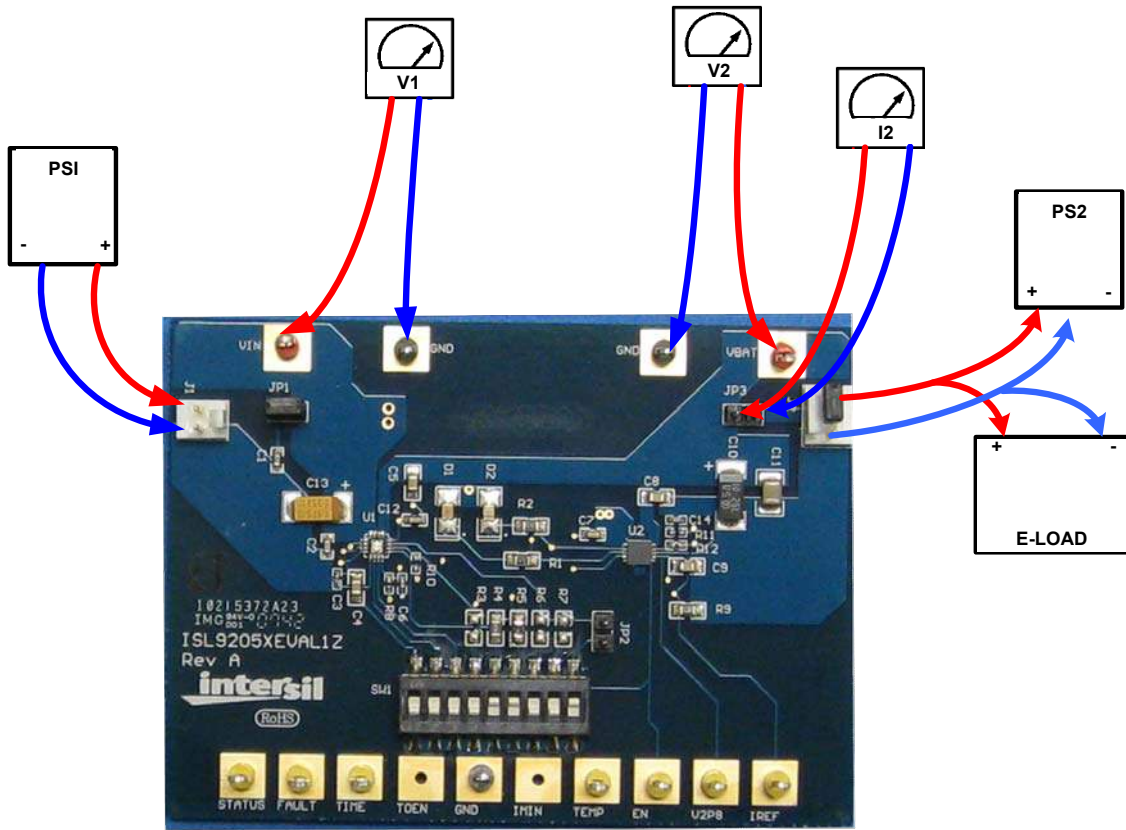

FIGURE 1. CONNECTION OF INSTRUMENTS

Detailed Description

The ISL9205xEVAL1Z is a complete evaluation platform addressing all datasheet specifications and functionality. The jumpers on the board facilitate the necessary connections, such as current measurement.

Jumpers

JP1 - A shunt installed on JP1 connects the input source from connector J1 to the circuit if input current measurement is not needed. The shunt can be replaced by a current meter if input current measurement is needed.

JP2 - Connection for the thermistor. An industrial standard 103ET type of thermistor or similar type that has a room temperature resistance of 10kΩ should be connected to JP2. If temperature measurement is not needed, a regular 10k resistor can be used to set a valid temperature window. Note that leaving JP2 open will cause the charge to shut down.

JP3 - A shunt installed on JP3 connects the VBAT pin to the output connector J2 if output current measurement is not needed. The shunt can be replaced by a current meter if output current measurement is needed.

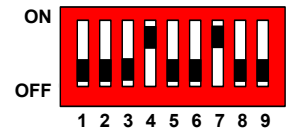

FIGURE 2. DIP SWITCH BIT DESCRIPTION

DIP Switch Settings

A 9-bit DIP switch is provided to set up current reference, end-of-charge (EOC) current, and so on. The functionality of the bits are described in Table 1.

TABLE 1. JUMPER SETTINGS

JUMPER	FUNCTION
JP1	Connect the input power at J1 to VIN pin
JP2	For thermistor connection
JP3	Connects VBAT to connector J2

TABLE 2. DIP SWITCH SETTINGS

BIT	DESCRIPTION	ON	OFF	REMARK
1	Time-out period setting	5.8 hours	3.5 hours	
2	Time-out enable	Disabled	Enabled	Not connected
3	Charger enable	Charger disabled	Charger enabled	
4	IMIN setting	IMIN = 80mA	IMIN = 10mA	
5	IREF setting 1	ICH = 800mA	IBAT = 90mA	BIT6 = OFF
6	IREF setting 2	ICH = 1A	IBAT = 800mA	BIT5 = ON
7	TEMP normal	Normal		All off simulates battery removal
8	TEMP high	Too hot		
9	TEMP low	Too cold		

Board Layout Information

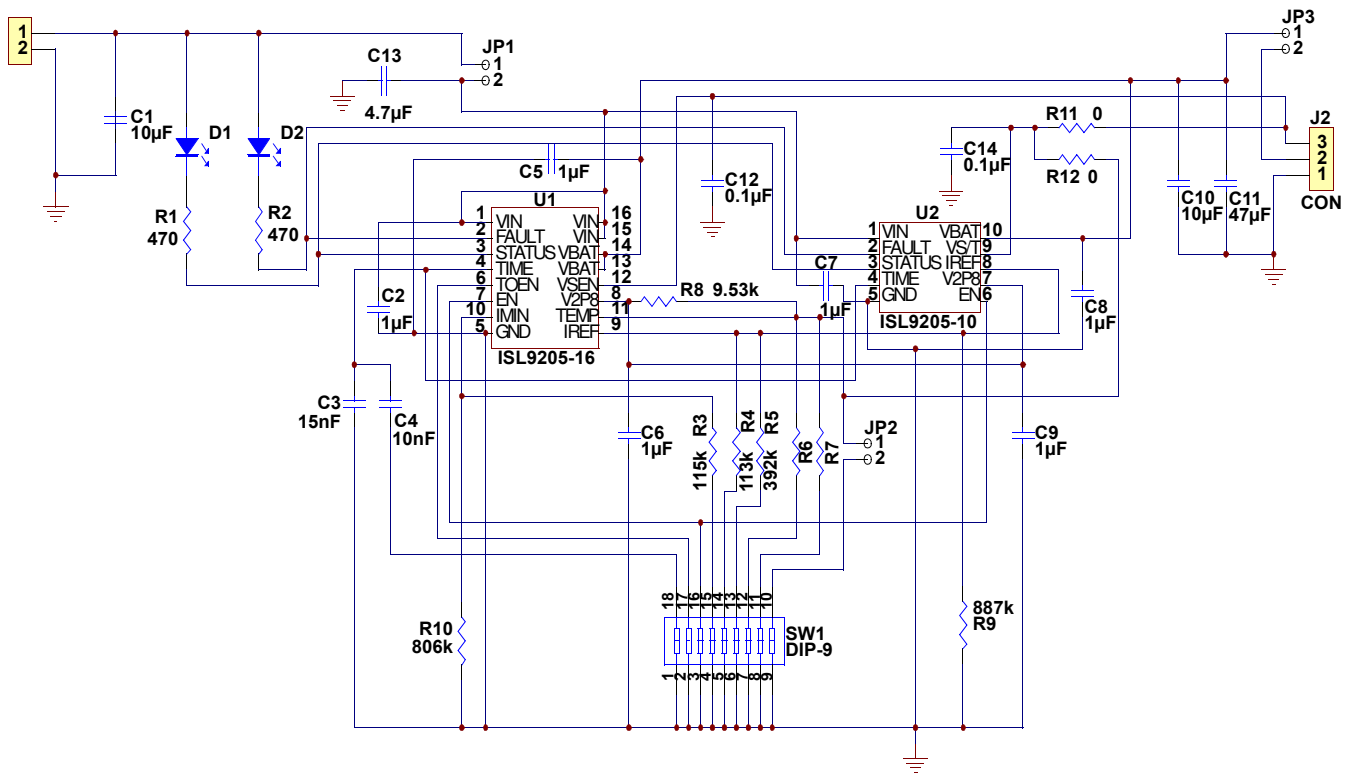

FIGURE 3. SCHEMATIC OF PCB BOARD

PCB Layout

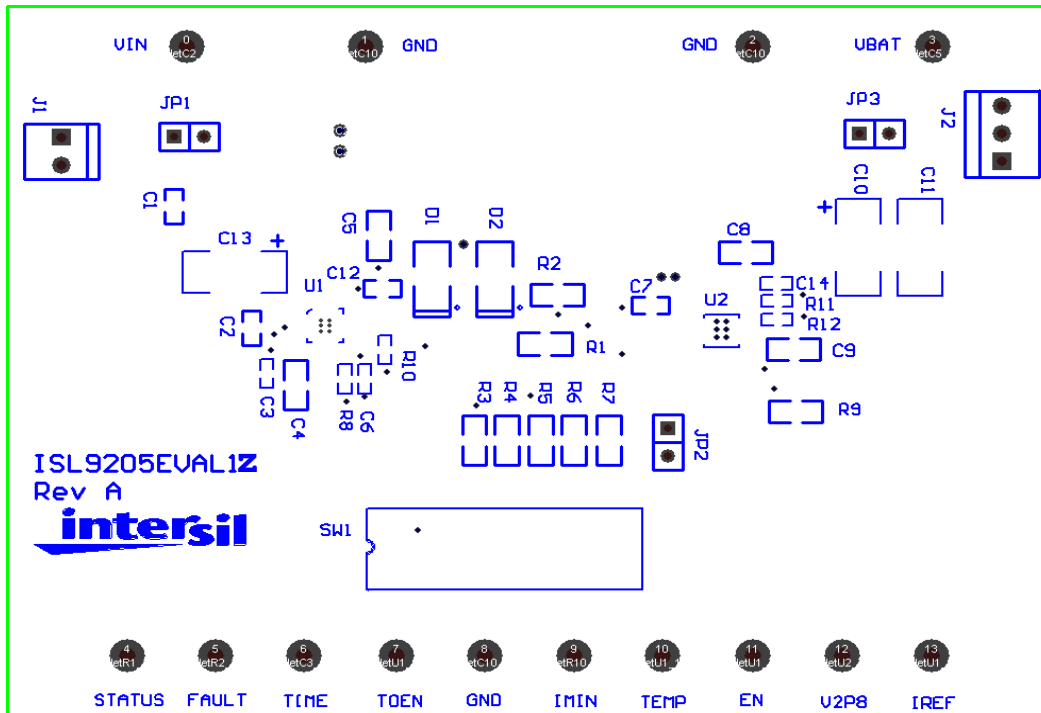

FIGURE 4. SILK LAYER

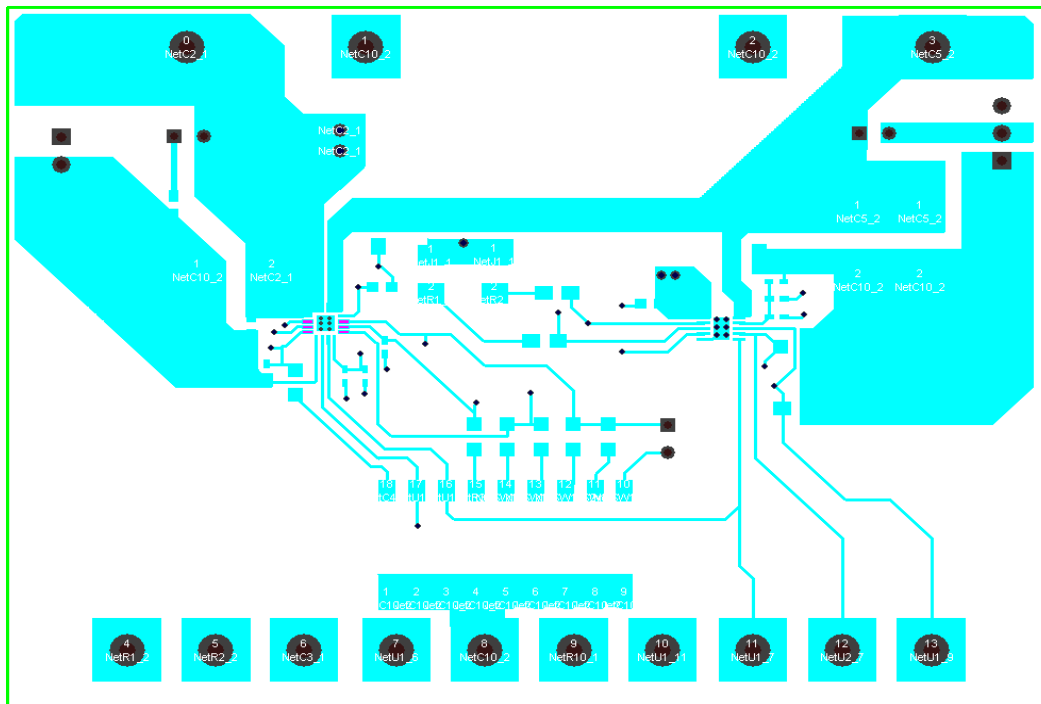

FIGURE 5. TOP LAYER

PCB Layout (Continued)

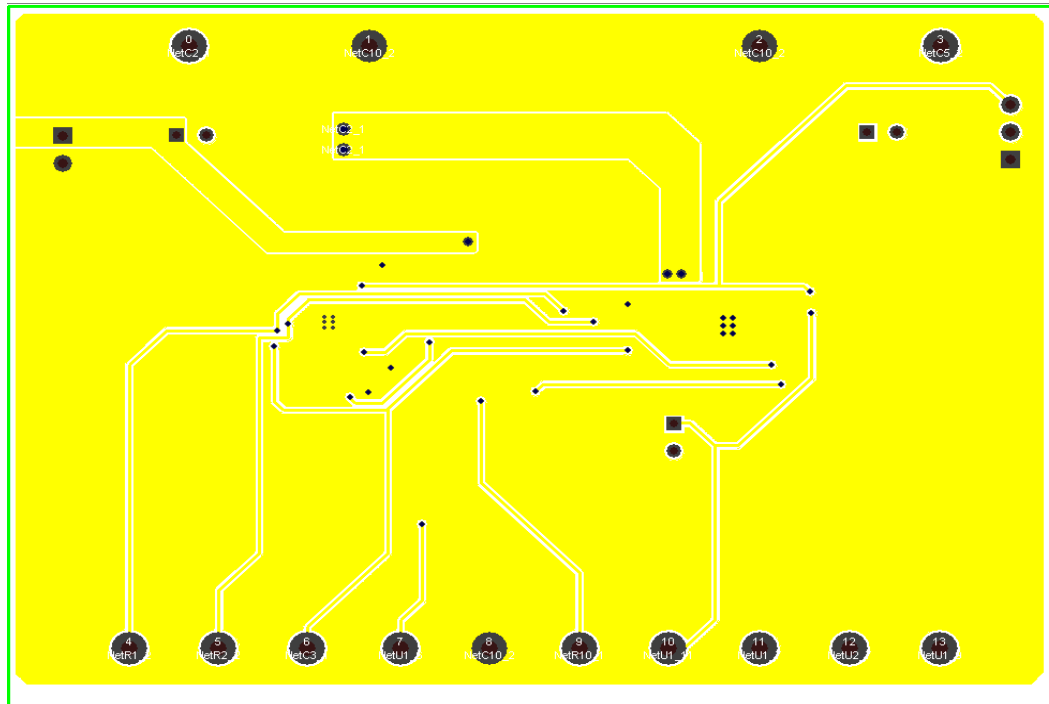

FIGURE 6. BOTTOM LAYER

ISL9205EVAL1Z Bill of Materials

ITEM	QTY	REFERENCE	PART DESCRIPTION	PCB FOOTPRINT	PART NUMBER	VENDOR
1	1	U1	ISL9205 Charger IC	3x3 QFN 16L	ISL9205	Intersil
2	2	R1, R2	470Ω, 5%, 1/8W, Chip	0805	ERJ-6GEYJ471V	Panasonic
3	1	R3	115k, 1%, 1/16W, Chip	0402	ERJ-2RKF1153X	Panasonic
4	1	R4	113k, 1%, 1/8W, Chip	0805	ERJ-6ENF1133V	Panasonic
5	1	R5	392k, 1%, 1/8W, Chip	0805	ERJ-6ENF3923V	Panasonic
6	1	R9	887k, 1%, 1/8W, Chip	0805	ERJ-6ENF8873V	Panasonic
7	1	R10	806k, 1%, 1/16W	0402	ERJ-2RKF8063X	Panasonic
8	1	R8	9.53k, 1%, 1/16W, Chip	0402	ERJ-2RKF9531X	Panasonic
9	2	R6, R7 (do not populate)				
10	2	R11, R12 (do not populate)	0Ω, 5%, 1/16W	0402	9C04021A0R00JLHF3	YAGEO
11	1	C13	4.7μF, 35V, Tantalum		ECS-T1VC475R	Panasonic
12	2	C1, C12	0.1μF, 50V, X7R Ceramic	0603	C1608X7R1H104K	TDK
13	2	C6, C14	0.1μF, 10V, X5R Ceramic	0402	C1005X5R1A104K	TDK
14	2	C2, C7	1.0μF, 6.3V, X5R Ceramic	0603	ECJ-1VB0J105K	Panasonic
15	1	C3	15nF, 16V, X7R Ceramic	0402	ECJ-0EB1C153K	Panasonic
16	1	C4	10nF, 50V, X7R Ceramic	0805	ECJ-2VB1H103K	Panasonic
17	2	C5, C8	1μF, 25V, X5R Ceramic	0805	ECJ-2FB1E105K	Panasonic
18	1	C9	1μF, 25V, X5R Ceramic	0805	ECJ-2FB1E105K	Panasonic
19	3	C11	47μF, 6.3V, X5R, Ceramic	1210	ECJ-4YB0J476M	Panasonic
20	1	C10	10μF, 25V, Tantalum		ECS-T1EC106R	Panasonic
21	1	J1	2.54mm Center Header, 2ckt		22-11-2022	Molex
22	1	SW1	DIP Switch, 9 POS, SMT	DIP18	SDA09H0SKD	ITT/C&K
23	1	J2	2.54mm Center Header, 3ckt		22-11-2032	Molex
24	2	VIN, VBAT	Test point, Red		5010	Keystone
25	9	FAULT, STATUS, TIME, IREF, IMIN, TOEN, EN, V2P8, TEMP	Test point, Yellow		5014	Keystone
26	3	GND1, GND2, GND3	Test point, Black		5011	Keystone
27	3	JP1, JP2, JP3	2.54mm header, 2ckt		22-28-4020	Molex
28	1	D1	Green LED	0805	SML-LXT0805GW-TR	Lumex
29	1	D2	Red LED	0805	SML-LXT0805IW-TR	Lumex

ISL9205DEVAL1Z Bill of Materials

ITEM	QTY	REFERENCE	PART DESCRIPTION	PCB FOOTPRINT	PART NUMBER	VENDOR
1	1	U1	ISL9205D Charger IC	3x3 DFN 10L	ISL9205D	Intersil
2	2	R1, R2	470Ω, 5%, 1/8W, Chip	0805	ERJ-6GEYJ471V	Panasonic
3	1	R4	113k, 1%, 1/8W, Chip	0805	ERJ-6ENF1133V	Panasonic
4	1	R5	392k, 1%, 1/8W, Chip	0805	ERJ-6ENF3923V	Panasonic
5	1	R9	887k, 1%, 1/8W, Chip	0805	ERJ-6ENF8873V	Panasonic
6	1	R8	9.53k, 1%, 1/16W, Chip	0402	ERJ-2RKF9531X	Panasonic
7	2	R6, R7 (do not populate)				
8	1	R11 (do not populate)				
9	1	R12	0Ω, 5%, 1/16W	0402	9C04021A0R00JLHF3	YAGEO
10	1	C13	4.7μF, 35V, Tantalum		ECS-T1VC475R	Panasonic
11	2	C1, C12	0.1μF, 50V, X7R Ceramic	0603	C1608X7R1H104K	TDK
12	2	C6, C14	0.1μF, 10V, X5R Ceramic	0402	C1005X5R1A104K	TDK
13	2	C2, C7	1.0μF, 6.3V, X5R Ceramic	0603	ECJ-1VB0J105K	Panasonic
14	1	C3	15nF, 16V, X7R Ceramic	0402	ECJ-0EB1C153K	Panasonic
15	1	C4	10nF, 50V, X7R Ceramic	0805	ECJ-2VB1H103K	Panasonic
16	2	C5, C8	1μF, 25V, X5R Ceramic	0805	ECJ-2FB1E105K	Panasonic
17	1	C9	1μF, 25V, X5R Ceramic	0805	ECJ-2FB1E105K	Panasonic
18	3	C11	47μF, 6.3V, X5R, Ceramic	1210	ECJ-4YB0J476M	Panasonic
19	1	C10	10μF, 25V, Tantalum		ECS-T1EC106R	Panasonic
20	1	J1	2.54mm Center Header, 2ckt		22-11-2022	Molex
21	1	SW1	DIP Switch, 9 POS, SMT	DIP18	SDA09H0SKD	ITT/C&K
22	1	J2	2.54mm Center Header, 3ckt		22-11-2032	Molex
23	2	VIN, VBAT	Test point, Red		5010	Keystone
24	7	FAULT, STATUS, TIME, IREF, EN, V2P8, TEMP	Test point, Yellow		5014	Keystone
25	3	GND1, GND2, GND3	Test point, Black		5011	Keystone
26	3	JP1, JP2, JP3	2.54mm header, 2ckt		22-28-4020	Molex
27	1	D1	Green LED	0805	SML-LXT0805GW-TR	Lumex
28	1	D2	Red LED	0805	SML-LXT0805IW-TR	Lumex

ISL9205AEVAL1Z, ISL9205BEVAL1Z, ISL9205CEVAL1Z Bill of Materials

ITEM	QTY	REFERENCE	PART DESCRIPTION	PCB FOOTPRINT	PART NUMBER	VENDOR
1	1	U1	ISL9205A, ISL9205B, ISL9205C Charger IC	3x3 DFN 10L	ISL9205A/B/C	Intersil
2	2	R1, R2	470Ω, 5%, 1/8W, Chip	0805	ERJ-6GEYJ471V	Panasonic
3	1	R4	113k, 1%, 1/8W, Chip	0805	ERJ-6ENF1133V	Panasonic
4	1	R5	392k, 1%, 1/8W, Chip	0805	ERJ-6ENF3923V	Panasonic
5	1	R9	887k, 1%, 1/8W, Chip	0805	ERJ-6ENF8873V	Panasonic
6	1	R8	9.53k, 1%, 1/16W, Chip	0402	ERJ-2RKF9531X	Panasonic
7	2	R6, R7 (do not populate)				
8	1	R11	0Ω, 5%, 1/16W	0402	9C04021A0R00JLHF3	YAGEO
9	1	R12 (do not populate)				
10	1	C13	4.7μF, 35V, Tantalum		ECS-T1VC475R	Panasonic
11	2	C1, C12	0.1μF, 50V, X7R Ceramic	0603	C1608X7R1H104K	TDK
12	2	C6, C14	0.1μF, 10V, X5R Ceramic	0402	C1005X5R1A104K	TDK
13	2	C2, C7	1.0μF, 6.3V, X5R Ceramic	0603	ECJ-1VB0J105K	Panasonic
14	1	C3	15nF, 16V, X7R Ceramic	0402	ECJ-0EB1C153K	Panasonic
15	1	C4	10nF, 50V, X7R Ceramic	0805	ECJ-2VB1H103K	Panasonic
16	2	C5, C8	1μF, 25V, X5R Ceramic	0805	ECJ-2FB1E105K	Panasonic
17	1	C9	1μF, 25V, X5R Ceramic	0805	ECJ-2FB1E105K	Panasonic
18	3	C11	47μF, 6.3V, X5R, Ceramic	1210	ECJ-4YB0J476M	Panasonic
19	1	C10	10μF, 25V, Tantalum		ECS-T1EC106R	Panasonic
20	1	J1	2.54mm Center Header, 2ckt		22-11-2022	Molex
21	1	SW1	DIP Switch, 9 POS, SMT	DIP18	SDA09H0SKD	ITT/C&K
22	1	J2	2.54mm Center Header, 3ckt		22-11-2032	Molex
23	2	VIN, VBAT	Test point, Red		5010	Keystone
24	7	FAULT, STATUS, TIME, IREF, EN, V2P8, TEMP	Test point, Yellow		5014	Keystone
25	3	GND1, GND2, GND3	Test point, Black		5011	Keystone
26	3	JP1, JP2, JP3	2.54mm header, 2ckt		22-28-4020	Molex
27	1	D1	Green LED	0805	SML-LXT0805GW-TR	Lumex
28	1	D2	Red LED	0805	SML-LXT0805IW-TR	Lumex

Notice

1. Descriptions of circuits, software and other related information in this document are provided only to illustrate the operation of semiconductor products and application examples. You are fully responsible for the incorporation or any other use of the circuits, software, and information in the design of your product or system. Renesas Electronics disclaims any and all liability for any losses and damages incurred by you or third parties arising from the use of these circuits, software, or information.
2. Renesas Electronics hereby expressly disclaims any warranties against and liability for infringement or any other claims involving patents, copyrights, or other intellectual property rights of third parties, by or arising from the use of Renesas Electronics products or technical information described in this document, including but not limited to, the product data, drawings, charts, programs, algorithms, and application examples.
3. No license, express, implied or otherwise, is granted hereby under any patents, copyrights or other intellectual property rights of Renesas Electronics or others.
4. You shall not alter, modify, copy, or reverse engineer any Renesas Electronics product, whether in whole or in part. Renesas Electronics disclaims any and all liability for any losses or damages incurred by you or third parties arising from such alteration, modification, copying or reverse engineering.
5. Renesas Electronics products are classified according to the following two quality grades: "Standard" and "High Quality". The intended applications for each Renesas Electronics product depends on the product's quality grade, as indicated below.
"Standard": Computers; office equipment; communications equipment; test and measurement equipment; audio and visual equipment; home electronic appliances; machine tools; personal electronic equipment; industrial robots; etc.
"High Quality": Transportation equipment (automobiles, trains, ships, etc.); traffic control (traffic lights); large-scale communication equipment; key financial terminal systems; safety control equipment; etc.
Unless expressly designated as a high reliability product or a product for harsh environments in a Renesas Electronics data sheet or other Renesas Electronics document, Renesas Electronics products are not intended or authorized for use in products or systems that may pose a direct threat to human life or bodily injury (artificial life support devices or systems; surgical implantations; etc.), or may cause serious property damage (space system; undersea repeaters; nuclear power control systems; aircraft control systems; key plant systems; military equipment; etc.). Renesas Electronics disclaims any and all liability for any damages or losses incurred by you or any third parties arising from the use of any Renesas Electronics product that is inconsistent with any Renesas Electronics data sheet, user's manual or other Renesas Electronics document.
6. When using Renesas Electronics products, refer to the latest product information (data sheets, user's manuals, application notes, "General Notes for Handling and Using Semiconductor Devices" in the reliability handbook, etc.), and ensure that usage conditions are within the ranges specified by Renesas Electronics with respect to maximum ratings, operating power supply voltage range, heat dissipation characteristics, installation, etc. Renesas Electronics disclaims any and all liability for any malfunctions, failure or accident arising out of the use of Renesas Electronics products outside of such specified ranges.
7. Although Renesas Electronics endeavors to improve the quality and reliability of Renesas Electronics products, semiconductor products have specific characteristics, such as the occurrence of failure at a certain rate and malfunctions under certain use conditions. Unless designated as a high reliability product or a product for harsh environments in a Renesas Electronics data sheet or other Renesas Electronics document, Renesas Electronics products are not subject to radiation resistance design. You are responsible for implementing safety measures to guard against the possibility of bodily injury, injury or damage caused by fire, and/or danger to the public in the event of a failure or malfunction of Renesas Electronics products, such as safety design for hardware and software, including but not limited to redundancy, fire control and malfunction prevention, appropriate treatment for aging degradation or any other appropriate measures. Because the evaluation of microcomputer software alone is very difficult and impractical, you are responsible for evaluating the safety of the final products or systems manufactured by you.
8. Please contact a Renesas Electronics sales office for details as to environmental matters such as the environmental compatibility of each Renesas Electronics product. You are responsible for carefully and sufficiently investigating applicable laws and regulations that regulate the inclusion or use of controlled substances, including without limitation, the EU RoHS Directive, and using Renesas Electronics products in compliance with all these applicable laws and regulations. Renesas Electronics disclaims any and all liability for damages or losses occurring as a result of your noncompliance with applicable laws and regulations.
9. Renesas Electronics products and technologies shall not be used for or incorporated into any products or systems whose manufacture, use, or sale is prohibited under any applicable domestic or foreign laws or regulations. You shall comply with any applicable export control laws and regulations promulgated and administered by the governments of any countries asserting jurisdiction over the parties or transactions.
10. It is the responsibility of the buyer or distributor of Renesas Electronics products, or any other party who distributes, disposes of, or otherwise sells or transfers the product to a third party, to notify such third party in advance of the contents and conditions set forth in this document.
11. This document shall not be reprinted, reproduced or duplicated in any form, in whole or in part, without prior written consent of Renesas Electronics.
12. Please contact a Renesas Electronics sales office if you have any questions regarding the information contained in this document or Renesas Electronics products.
(Note 1) "Renesas Electronics" as used in this document means Renesas Electronics Corporation and also includes its directly or indirectly controlled subsidiaries.
(Note 2) "Renesas Electronics product(s)" means any product developed or manufactured by or for Renesas Electronics.

(Rev.4.0-1 November 2017)



SALES OFFICES

Renesas Electronics Corporation

<http://www.renesas.com>

Refer to "<http://www.renesas.com/>" for the latest and detailed information.

Renesas Electronics America Inc.

1001 Murphy Ranch Road, Milpitas, CA 95035, U.S.A.
Tel: +1-408-432-8888, Fax: +1-408-434-5351

Renesas Electronics Canada Limited

9251 Yonge Street, Suite 8309 Richmond Hill, Ontario Canada L4C 9T3
Tel: +1-905-237-2004

Renesas Electronics Europe Limited

Dukes Meadow, Millboard Road, Bourne End, Buckinghamshire, SL8 5FH, U.K
Tel: +44-1628-651-700, Fax: +44-1628-651-804

Renesas Electronics Europe GmbH

Arcadiastrasse 10, 40472 Düsseldorf, Germany
Tel: +49-211-6503-0, Fax: +49-211-6503-1327

Renesas Electronics (China) Co., Ltd.

Room 1709 Quantum Plaza, No.27 ZhichunLu, Haidian District, Beijing, 100191 P. R. China
Tel: +86-10-8235-1155, Fax: +86-10-8235-7679

Renesas Electronics (Shanghai) Co., Ltd.

Unit 301, Tower A, Central Towers, 555 Langao Road, Putuo District, Shanghai, 200333 P. R. China
Tel: +86-21-2226-0888, Fax: +86-21-2226-0999

Renesas Electronics Hong Kong Limited

Unit 1601-1611, 16/F., Tower 2, Grand Century Place, 193 Prince Edward Road West, Mongkok, Kowloon, Hong Kong
Tel: +852-2265-6688, Fax: +852 2886-9022

Renesas Electronics Taiwan Co., Ltd.

13F, No. 363, Fu Shing North Road, Taipei 10543, Taiwan
Tel: +886-2-8175-9600, Fax: +886 2-8175-9670

Renesas Electronics Singapore Pte. Ltd.

80 Bendemeer Road, Unit #06-02 Hyflux Innovation Centre, Singapore 339949
Tel: +65-6213-0200, Fax: +65-6213-0300

Renesas Electronics Malaysia Sdn.Bhd.

Unit 1207, Block B, Menara Amcorp, Amcorp Trade Centre, No. 18, Jln Persiaran Barat, 46050 Petaling Jaya, Selangor Darul Ehsan, Malaysia
Tel: +60-3-7955-9390, Fax: +60-3-7955-9510

Renesas Electronics India Pvt. Ltd.

No.777C, 100 Feet Road, HAL 2nd Stage, Indiranagar, Bangalore 560 038, India
Tel: +91-80-67208700, Fax: +91-80-67208777

Renesas Electronics Korea Co., Ltd.

17F, KAMCO Yangjae Tower, 262, Gangnam-daero, Gangnam-gu, Seoul, 06265 Korea
Tel: +82-2-558-3737, Fax: +82-2-558-5338