

### STEVAL-CCA057V5 evaluation board user guidelines for dual operational amplifiers in a DFN8 package

#### Introduction

The STEVAL-CCA057V5 evaluation board from STMicroelectronics is designed to help customers quickly prototype new dual op amp circuits in a DFN8 package and reduce design time.

The evaluation board can be used with almost any STMicroelectronics dual op amp in various configurations and applications. The evaluation board is a bare board (that is, there are no components or amplifier soldered to the board; these must be ordered separately).

This document provides:

- A description of the evaluation board.
- A layout of the top and bottom layers.
- Some examples of classic configurations that can be tested with the board.

Figure 1. DFN8 2x2 pinout

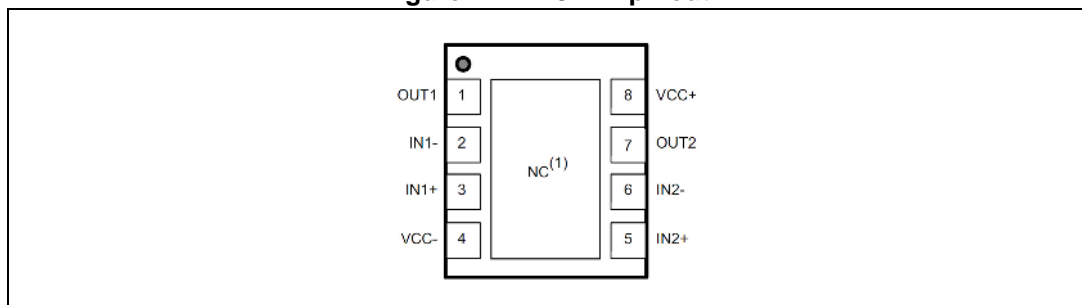
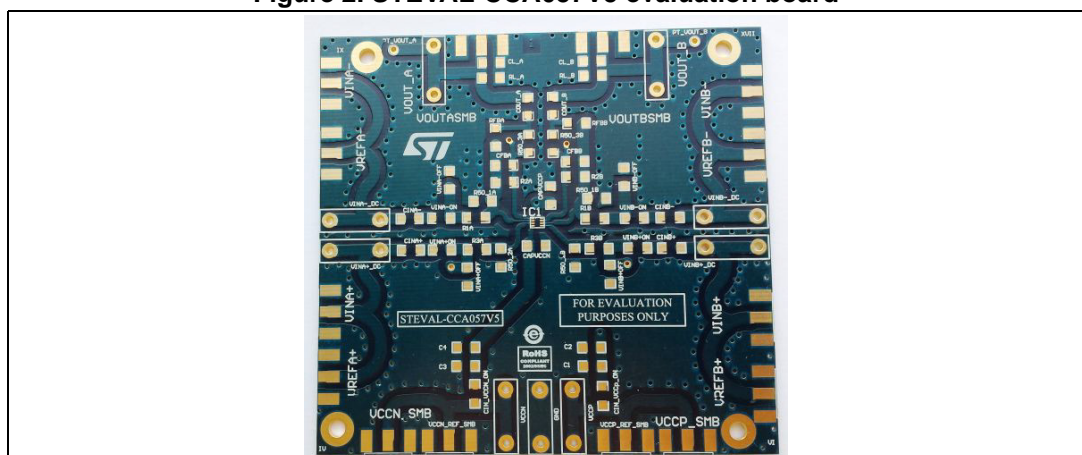

Figure 2. STEVAL-CCA057V5 evaluation board



---

# Contents

<b>1</b>	<b>Description</b> .....	<b>3</b>
<b>2</b>	<b>Layout</b> .....	<b>6</b>
<b>3</b>	<b>Different possible configurations</b> .....	<b>7</b>
3.1	Low-pass Sallen-key configuration .....	7
3.2	High-pass Sallen-key configuration .....	8
3.3	Instrumentation amplifier .....	9
3.4	Transimpedance configuration .....	10
3.5	AC coupled circuit configuration .....	11
<b>4</b>	<b>Associated products</b> .....	<b>13</b>
<b>5</b>	<b>Revision history</b> .....	<b>14</b>



# 1 Description

This board is designed with versatility in mind, and allows many circuits to be constructed easily and quickly.

A few possible circuits are as follows:

- Voltage follower
- Non-inverting amplifier
- Inverting amplifier
- Sallen-key filter
- Instrument amplifier
- AC-coupled circuit
- Out-of-loop compensation circuit

## Circuit

The circuit schematic in [Figure 3](#) shows the connections for all possible components. Each configuration uses only some of the components.

The board is designed for surface-mounted components and can be used to perform on board characterization prior to the integration of STMicroelectronics products in your designs. Resistor and capacitor footprints are implemented for the 1206 series.

Figure 3. Evaluation board schematics

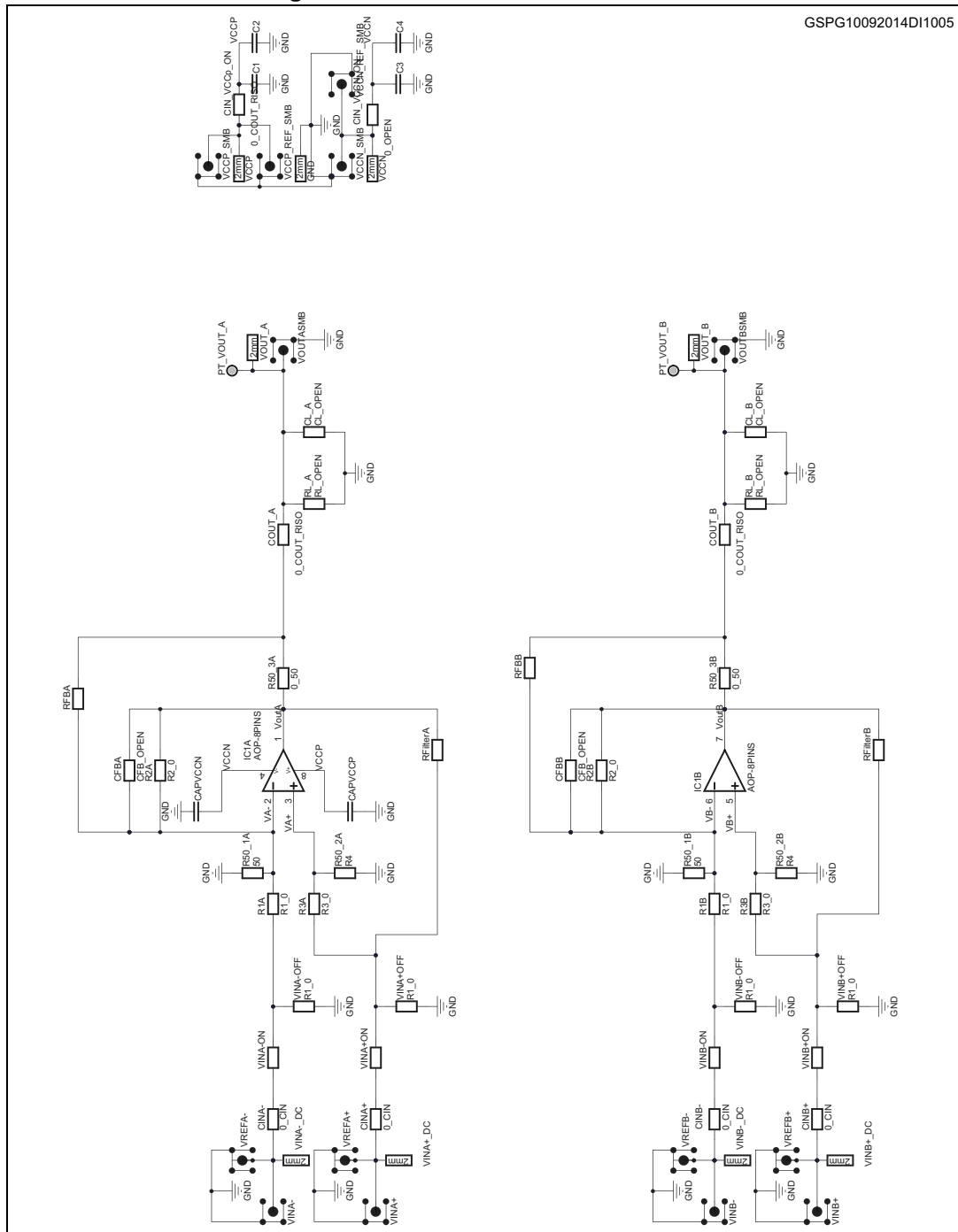

**Power requirements**

A 0Ω resistance must be connecting on CIN\_VCCN\_ON and CIN\_VCCP\_ON in order to power supply the dual amplifier.

A set of two decoupling capacitors (C1, C2 and C3, C4) have been implemented on both power supply pins, as to benefit from the maximum performances of ST products. In order to reject low frequencies, 1 μF and 10 μF are good values for these.

Others decoupling capacitors (CAPVCCN, CAPVCCP) as close as possible of the MSO10 package, might also be used to obtain an excellent power supply decoupling. 100pF values can be used in order to reject high frequencies.

When using single-supply circuits, the negative supply is shorted to ground by bridging C3 or C4 capacitances. Power is therefore between VCCP and GND.

### Output options

The outputs have additional resistors (RL\_A, RL\_B) and capacitors (CL\_A, CL\_B) placements for loading. Or it might be used as an anti-alias filter, or to limit amplifier output noise by reducing its output bandwidth.

*Note: Operational amplifiers are sensitive to output capacitance and may oscillate. In event of oscillation, reduce output capacitance by using shorter cables, or add a resistor in series on COUT\_A, COUT\_B placement with a suitable value in order to improve amplifier phase margin.*

### Measurement tips

In the datasheet, some measurements, as settling time, peaking, have been done with 50  $\Omega$  output equipment. In order to keep the integrity of the square input signal, the input tracks from VINA+, VINB+, VINA-, VINB-, have an impedance of 50  $\Omega$ .

And in order to adapt input impedance, 50  $\Omega$  resistances can be add on the R50\_1A, R50\_2A and R50\_1B, R50\_2B.

## 2 Layout

The board has the following physical characteristics.

- Board dimensions: 3526 x 3300 mils (89.6 x 83.8 mm)
- 2-layer PCB
- Both sides have a ground plane.

For Vout\_A, Vout\_B, VinA+, VinA-, VinB+ and VinB- female SMB or female 2 mm connectors can be implanted. You can also implant test points on these voltages. They will facilitate the visualization of your signals.

Top and bottom layers are shown on [Figure 4](#) and [Figure 5](#):

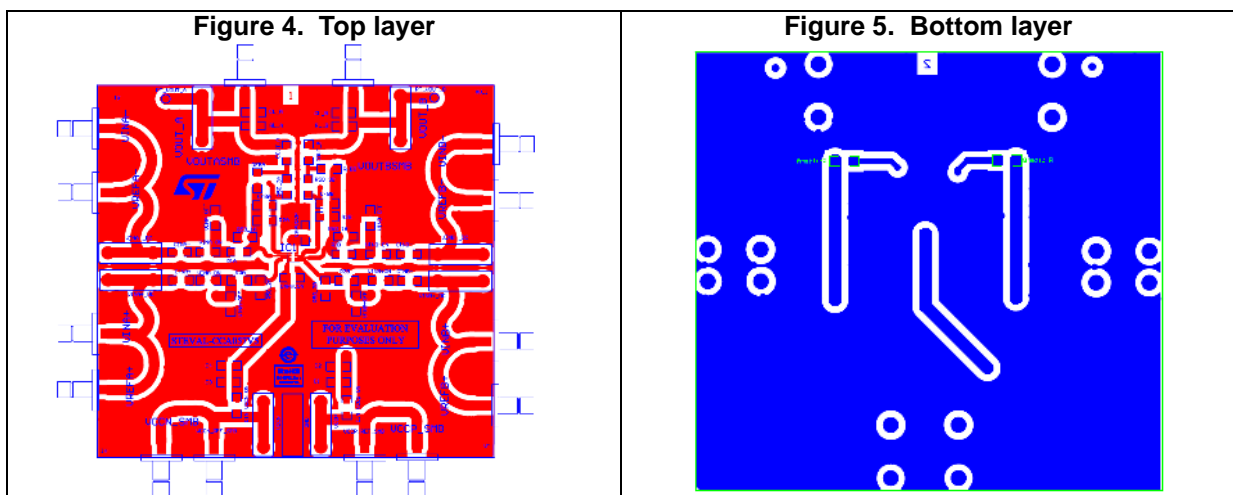

### 3 Different possible configurations

The following provides some instructions on how to set up the board in order to perform several classical configurations.

- [Figure 6: Low-pass Sallen-key 4<sup>th</sup> order configuration](#)
- [Figure 7: High-pass Sallen-key configuration](#)
- [Figure 8: Instrumentation amplifier](#)
- [Figure 9: Transimpedance configuration](#)
- [Figure 10: AC coupled circuit configuration](#)

You can also put several boards in cascade which allows you to obtain a more complex configuration.

#### 3.1 Low-pass Sallen-key configuration

The following low-pass Sallen-key configuration is a fourth order filter configuration. This circuit has 80dB roll-off per decade.

The transfer function is:

##### Equation 1

$$\frac{V_{out}}{V_{in}} = \frac{1 + \frac{RFA}{RGA}}{1 + \left( R1.C2 \left( 1 - \frac{RFA}{RGA} \right) + C1(R1+R2) \right) j\omega + R1.R2.C1.C2(j\omega)^2} * \frac{1 + \frac{RFB}{RGB}}{1 + \left( R3.C4 \left( 1 - \frac{RFB}{RGB} \right) + C3(R3+R4) \right) j\omega + R3.R4.C3.C4(j\omega)^2}$$

##### Equation 2

$$G = \left( 1 + \frac{RFA}{RGA} \right) * \left( 1 + \frac{RFB}{RGB} \right)$$

Figure 6. Low-pass Sallen-key 4<sup>th</sup> order configuration

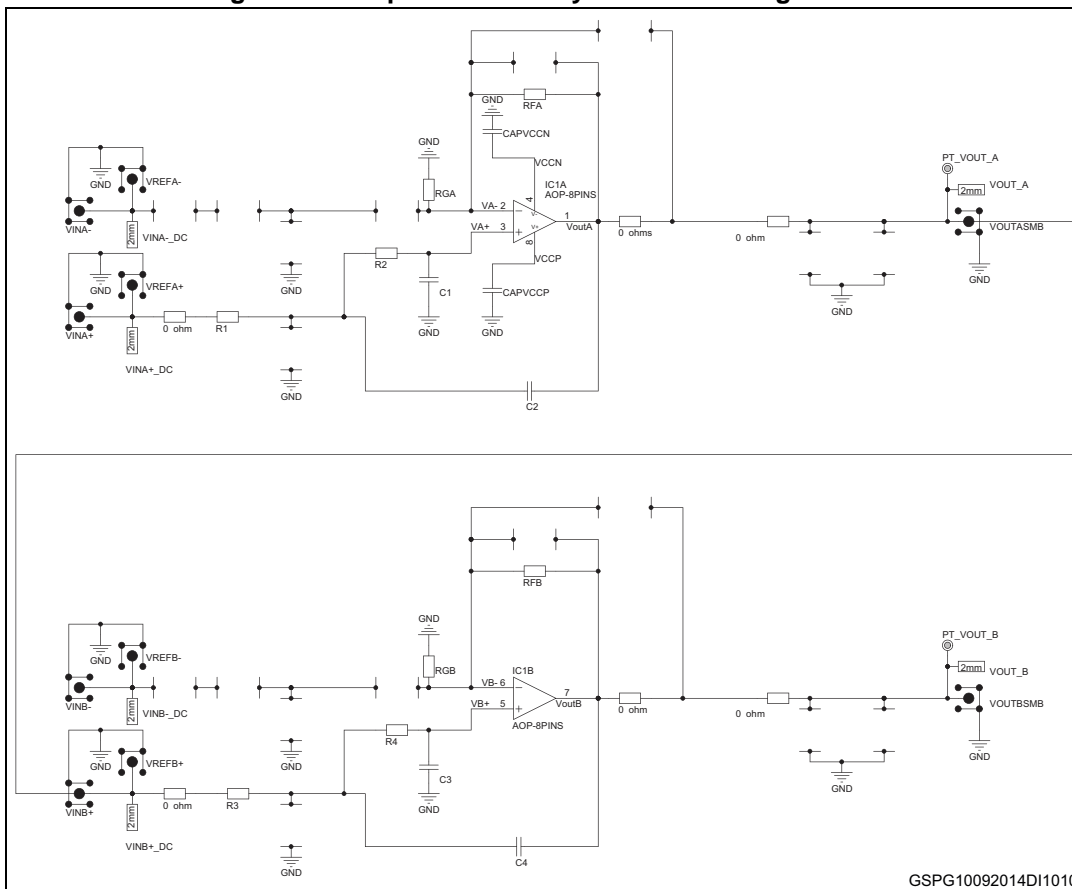

GSPG10092014DI1010

### 3.2 High-pass Sallen-key configuration

Like the low-pass Sallen-key configuration above, this one is a fourth order. It has a slope of +80dB per decade.

The transfer function is:

**Equation 3**

$$\frac{V_{out}}{V_{in}} = \frac{\left(1 + \frac{RFA}{RGA}\right) R1.R2.C1.C2.(j\omega)^2}{1 + \left(R2(C1+C2) - R1.C2.\frac{RFA}{RGA}\right) j\omega + R1.R2.C1.C2.(j\omega)^2} * \frac{\left(1 + \frac{RFB}{RGB}\right) R3.R4.C3.C4.(j\omega)^2}{1 + \left(R4(C3+C4) - R3.C4.\frac{RFB}{RGB}\right) j\omega + R3.R4.C3.C4.(j\omega)^2}$$

**Equation 4**

$$G = \left(1 + \frac{RFA}{RGA}\right) * \left(1 + \frac{RFB}{RGB}\right)$$





Figure 7. High-pass Sallen-key configuration

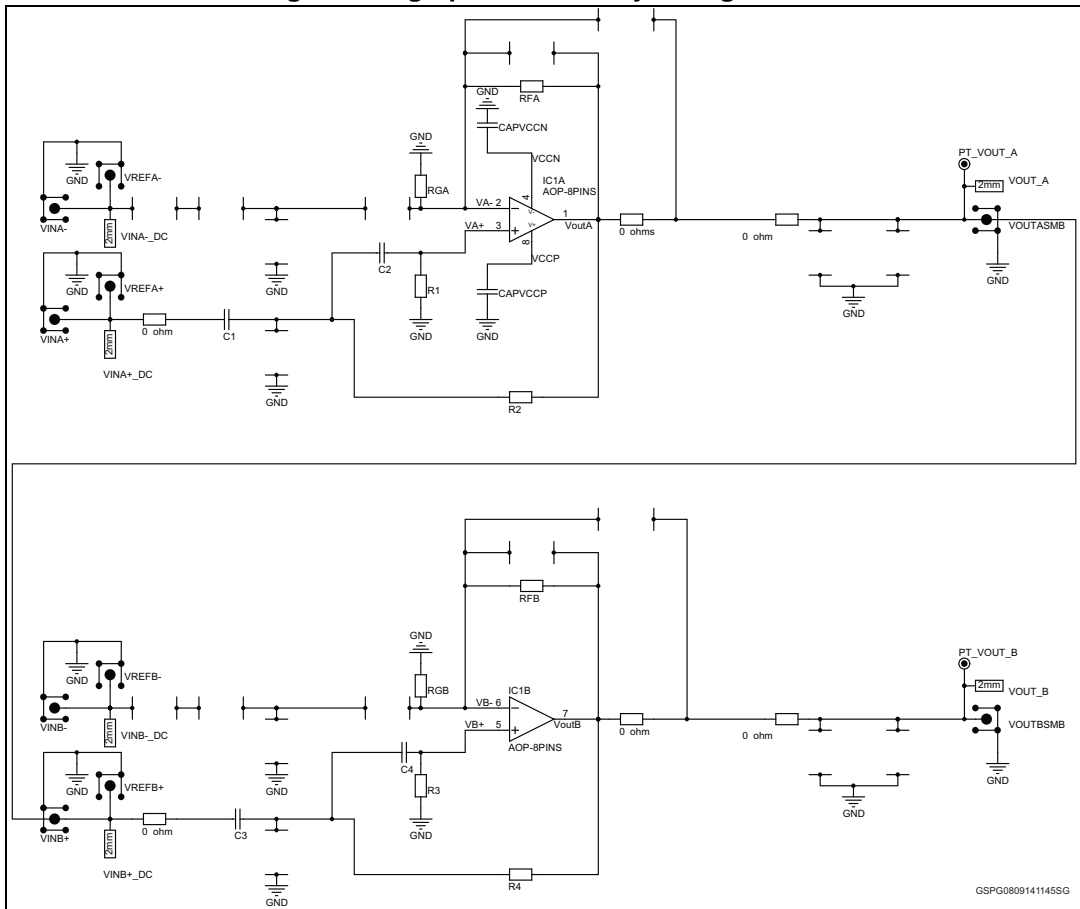

The upper limit of the frequency range is determined by the GBP of the Opamp

$$F \ll \frac{GBP}{1 + \frac{RFA}{RG}}$$

### 3.3 Instrumentation amplifier

The instrumentation amplifier are generally used for precise measurement in a differential way.

The architecture of Instrumentation amplifier with dual opamps is the simplest one. The input impedance is high as the non-inverting of the both opamps are used as input.

By considering  $R1.R2=RFA.RFB$

And  $Vout=Vreference$  for  $Vdiff = 0V$

The gain can be expressed as follow:

Equation 5

$$G = 1 + \frac{RFB}{Rg} + \frac{R1}{Rg} + \frac{R1}{RFA}$$

Figure 8. Instrumentation amplifier

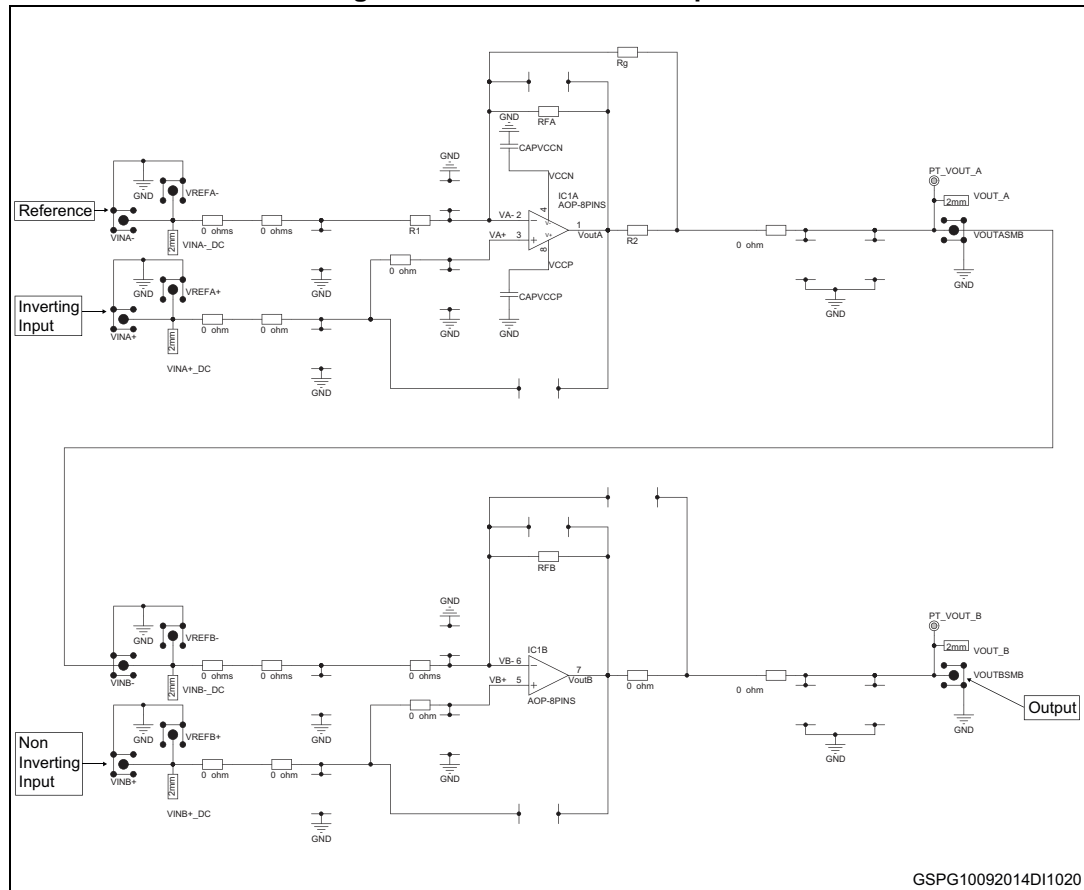

GSPG10092014DI1020

### 3.4 Transimpedance configuration

The [Figure 9](#) shows how to configure op-amp IC1A as a transimpedance amplifier (TIA). The output voltage of the TIA is the input current multiplied by the feedback resistor RFA:

Equation 6

$$VOUT_A = (I_{in} + I_{bias}) * RFA - V_{os}$$

where  $I_{in}$  is defined as the input current source applied at the VINA- pad,  $I_{BIAS}$  is the input bias current, and  $V_{OS}$  is the input offset voltage of the op amp. For the type of usage, the feedback resistor RFA is generally high and the impedance seen on the VA- node is pretty capacitive (ex: photodiode). In order to stabilize the Opamp it is recommended to connect a feedback capacitance CF.

Figure 9. Transimpedance configuration

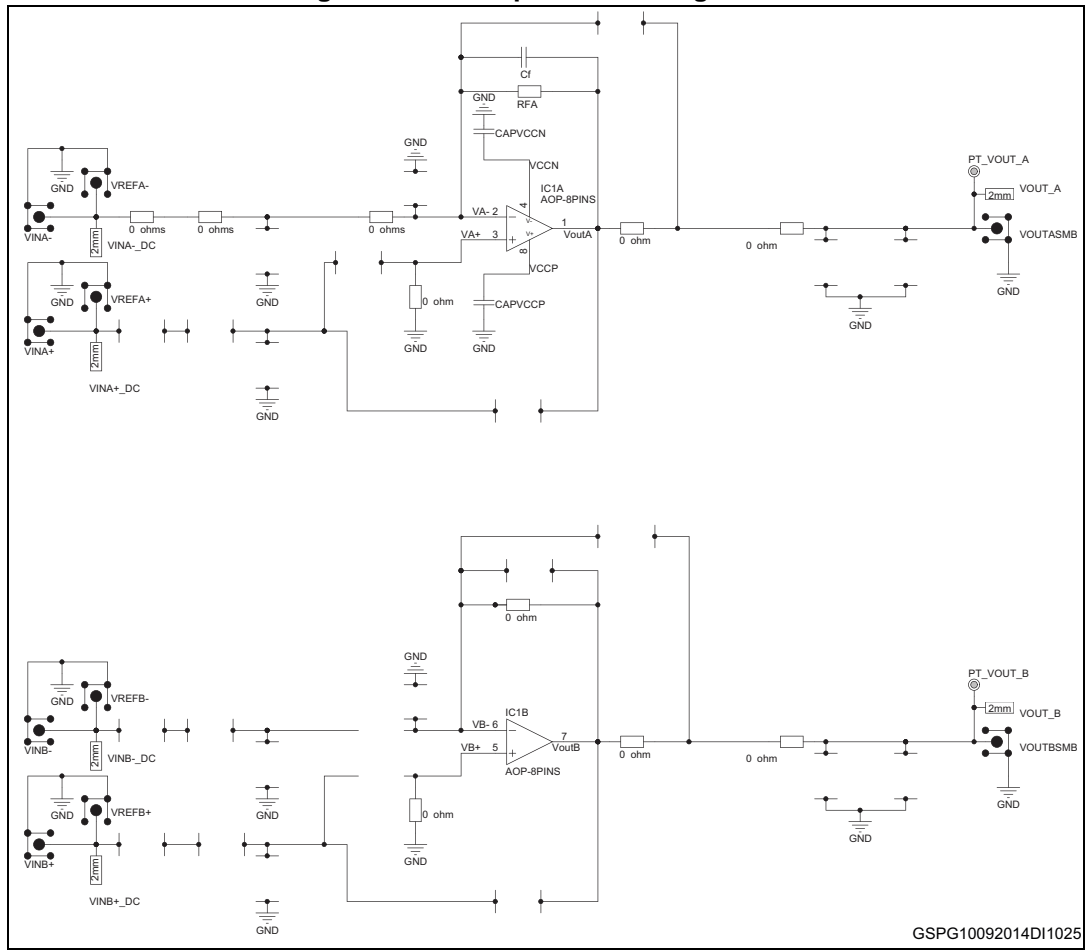

GSPG10092014DI1025

Note: If only IC1A opamp is used as transimpedance amplifier, the second one IC1B should be configure in follower mode in order to avoid any undesired oscillation on its output.

### 3.5 AC coupled circuit configuration

This typical configuration allows you to amplify the AC part only of the input signal. As for example typical stereo audio amplifier.

Figure 10. AC coupled circuit configuration

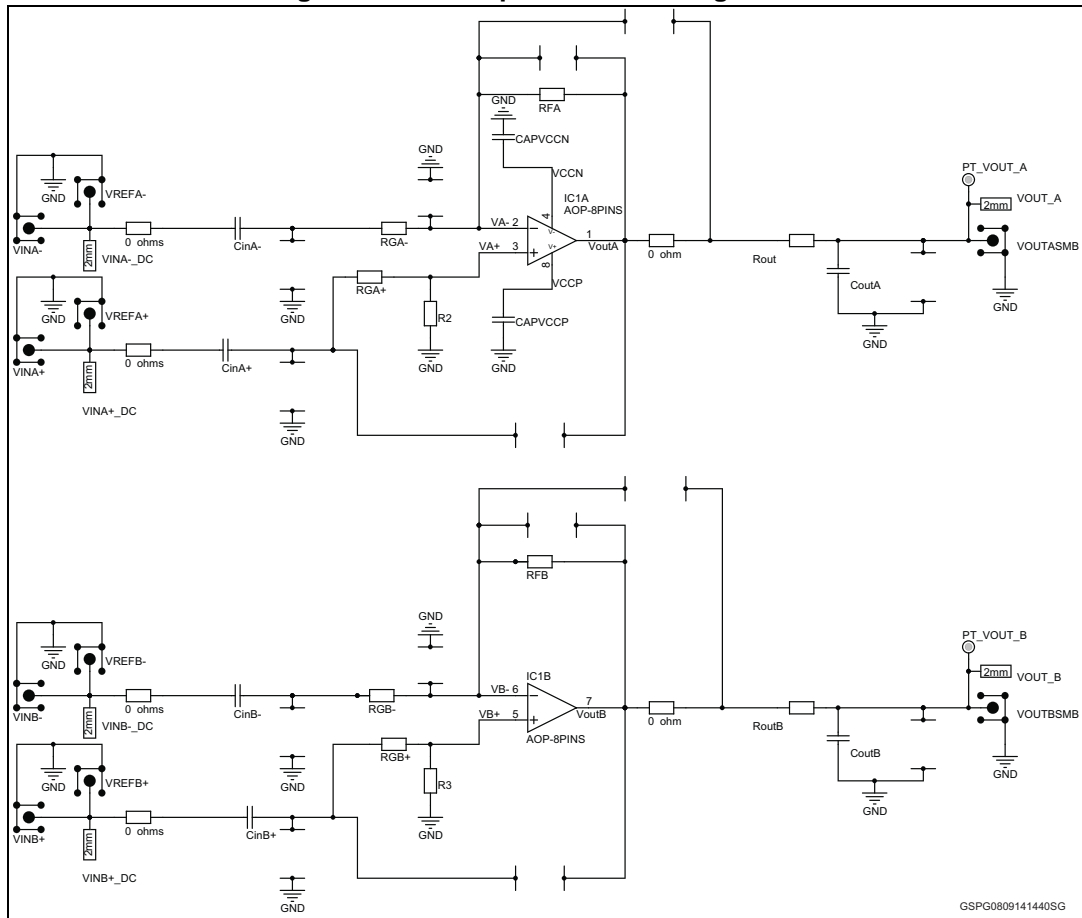

GSPG0809141440SG

## 4 Associated products

**Table 1. Associated products**

Part number	General description
LM258IQ2T	Low-power dual op-amps with low input bias current
LM2904IQ2T	Low power, bipolar op-amp
LM358IQ2T	Low-power dual op-amps with low input bias current
LMV822IQ2T	Low power, high accuracy, general purpose operational amplifier
LMX358IQ2T	Low-power, general-purpose operational amplifier
TSV522IQ2T	High merit factor (1.15 MHz for 45 $\mu$ A) CMOS op-amps
TSV522AIQ2T	High merit factor (1.15 MHz for 45 $\mu$ A) CMOS op-amps
TSV630IQ2T	Micro-power CMOS op-amp with standby
TSV632IQ2T	Micro-power CMOS op-amp
TSV632AIQ2T	Micro-power CMOS op-amp
TSV852IQ2T	Low-power, high accuracy, general-purpose operational amplifier
TSV912IQ2T	Rail to rail input/output widebandwidth op-amps
TSV991IQ2T	Rail to rail input/output high merit factor op-amps
TSZ122IQ2T	Very high accuracy (5 $\mu$ V) zero drift micropower 5 V

## 5 Revision history

Table 2. Document revision history

Date	Revision	Changes
15-Sep-2014	1	Initial release.

**IMPORTANT NOTICE – PLEASE READ CAREFULLY**

STMicroelectronics NV and its subsidiaries ("ST") reserve the right to make changes, corrections, enhancements, modifications, and improvements to ST products and/or to this document at any time without notice. Purchasers should obtain the latest relevant information on ST products before placing orders. ST products are sold pursuant to ST's terms and conditions of sale in place at the time of order acknowledgement.

Purchasers are solely responsible for the choice, selection, and use of ST products and ST assumes no liability for application assistance or the design of Purchasers' products.

No license, express or implied, to any intellectual property right is granted by ST herein.

Resale of ST products with provisions different from the information set forth herein shall void any warranty granted by ST for such product.

ST and the ST logo are trademarks of ST. All other product or service names are the property of their respective owners.

Information in this document supersedes and replaces information previously supplied in any prior versions of this document.

© 2014 STMicroelectronics – All rights reserved