Contents

1	Description	3
2	Layout	6
3	Different possible configurations	7
3.1	Low-pass Sallen-key configuration	7
3.2	High-pass Sallen-key configuration	8
3.3	Instrumentation amplifier	9
3.4	Transimpedance configuration	11
3.5	AC coupled circuit configuration	12
4	Associated products	13
5	Revision history	14

1 Description

This board is designed with versatility in mind, and allows many circuits to be constructed easily and quickly.

A few possible circuits are as follows:

- Voltage follower
- Non-inverting amplifier
- Inverting amplifier
- Sallen-key filter
- Instrument amplifier
- AC-coupled circuit
- Out-of-loop compensation circuit

Circuit

The circuit schematic in [Figure 3](#) shows the connections for all possible components. Each configuration uses only some of the components.

The board is designed for surface-mounted components and can be used to perform on board characterization prior to the integration of STMicroelectronics products in your designs. Resistor and capacitor footprints are implemented for the 1206 series.

Figure 3. Evaluation board schematics

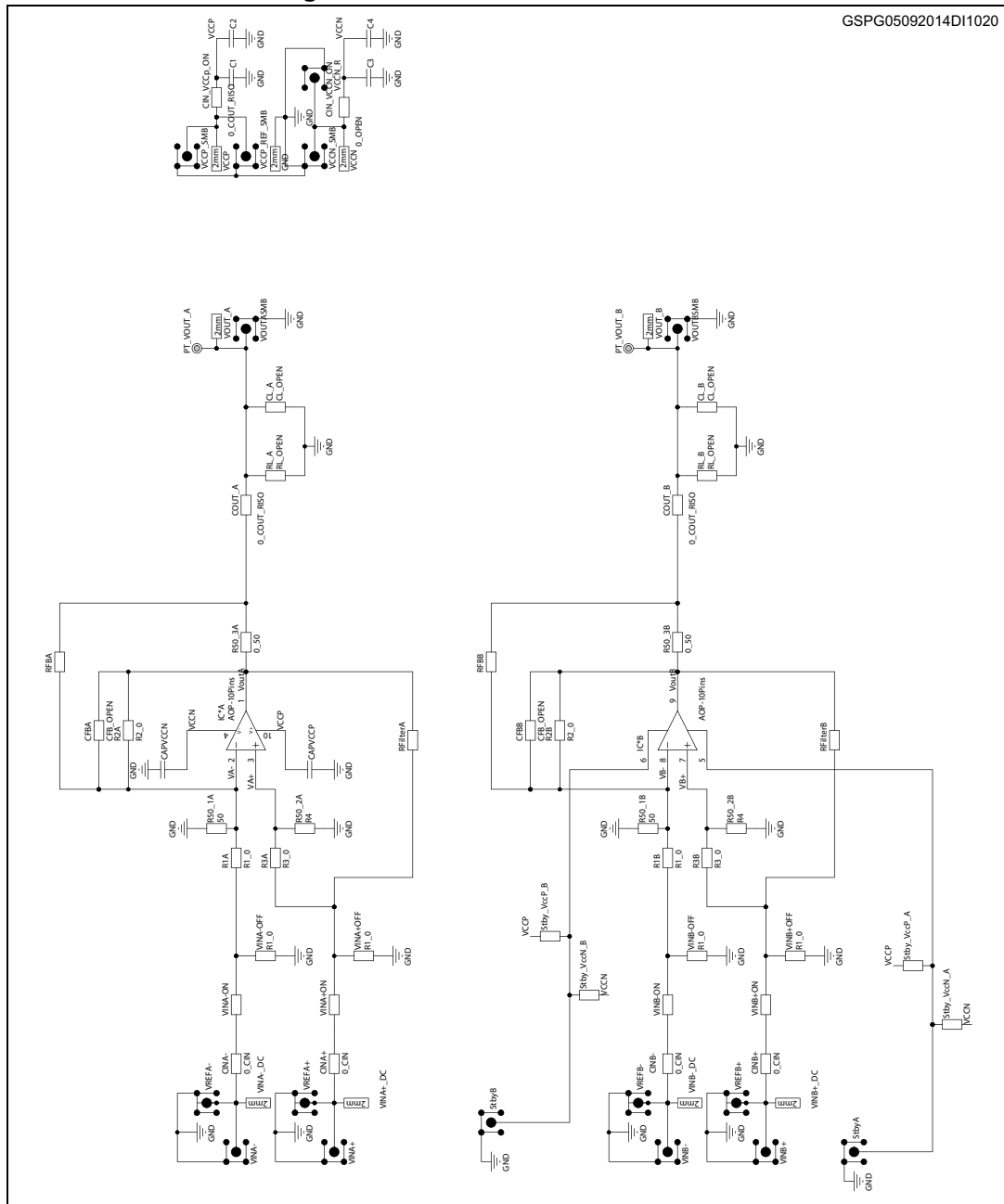

Power requirements

A 0 Ω resistance must be connecting on CIN_VCCN_ON and CIN_VCCP_ON in order to supply power to the dual amplifier.

A set of two decoupling capacitors (C1, C2 and C3, C4) have been implemented on both power supply pins, so as to benefit from the maximum performance of ST products. In order to reject low frequencies, 1 μF and 10 μF are good values for these.

Others decoupling capacitors (CAPVCCN, CAPVCCP) as close as possible to the SO8 package, might also be used to obtain excellent power supply decoupling. 100 pF values can be used in order to reject high frequencies.

When using single-supply circuits, the negative supply is shorted to ground by bridging C3 or C4 capacitances. Power is therefore between VCCP and GND.

Output options

The outputs have additional resistor (RL_A, RL_B) and capacitor (CL_A, CL_B) placements for loading. Or it might be used as an anti-alias filter, or to limit amplifier output noise by reducing its output bandwidth.

Note: Operational amplifiers are sensitive to output capacitance and may oscillate. In the event of oscillation, reduce output capacitance by using shorter cables, or add a resistor in series on COUT_A, COUT_B placement with a suitable value in order to improve amplifier phase margin.

Measurement tips

In the datasheet, some measurements, such as settling time and peaking, have been performed with 50 Ω output equipment. In order to keep the integrity of the square input signal, the input tracks from VINA+, VINB+, VINA-, VINB-, have an impedance of 50 Ω .

And in order to adapt input impedance, 50 Ω resistances can be added on the R50_1A, R50_2A and R50_1B, R50_2B.

2 Layout

The board has the following physical characteristics.

- Board dimensions: 3526 x 3300 mils (89.6 x 83.8 mm)
- 2-layer PCB
- Both sides have a ground plane.

For StandbyA, StandbyB, Vout_A, Vout_B, VinA+, VinA-, VinB+ and VinB- female SMB or female 2mm connectors can be implanted. You can also implant test points on these voltages. They will facilitate the visualization of your signals.

Top and bottom layers are shown on [Figure 4](#) and [Figure 5](#):

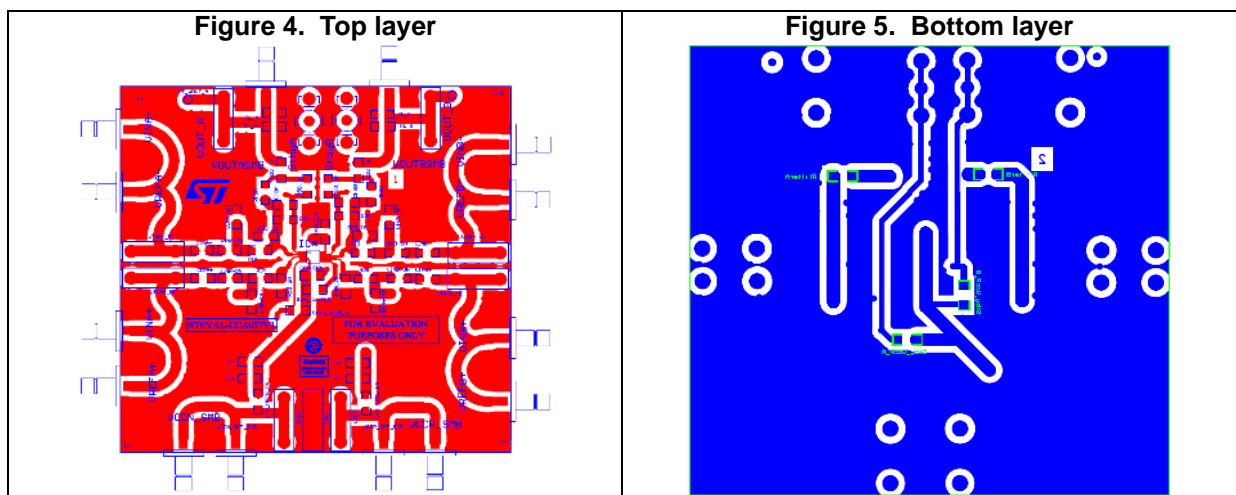

3 Different possible configurations

The following provides some instructions on how to set up the board in order to perform several classical configurations.

- [Figure 6: Low-pass Sallen-key 4th order configuration](#)
- [Figure 7: High-pass Sallen-key configuration](#)
- [Figure 8: Instrumentation amplifier](#)
- [Figure 9: Transimpedance configuration](#)
- [Figure 10: AC coupled circuit configuration](#)

You can also put several boards in cascade which allows you to obtain a more complex configurations.

3.1 Low-pass Sallen-key configuration

The following low-pass Sallen-key configuration is a fourth order filter configuration. This circuit has 80 dB roll-off per decade.

The transfer function is:

Equation 1

$$\frac{V_{out}}{V_{in}} = \frac{1 + \frac{RFA}{RGA}}{1 + \left(R1.C2 \left(1 - \frac{RFA}{RGA} \right) + C1(R1+R2) \right) j\omega + R1.R2.C1.C2(j\omega)^2} * \frac{1 + \frac{RFB}{RGB}}{1 + \left(R3.C4 \left(1 - \frac{RFB}{RGB} \right) + C3(R3+R4) \right) j\omega + R3.R4.C3.C4(j\omega)^2}$$

The low frequency gain is:

Equation 2

$$G = \left(1 + \frac{RFA}{RGA} \right) * \left(1 + \frac{RFB}{RGB} \right)$$

Figure 6. Low-pass Sallen-key 4th order configuration

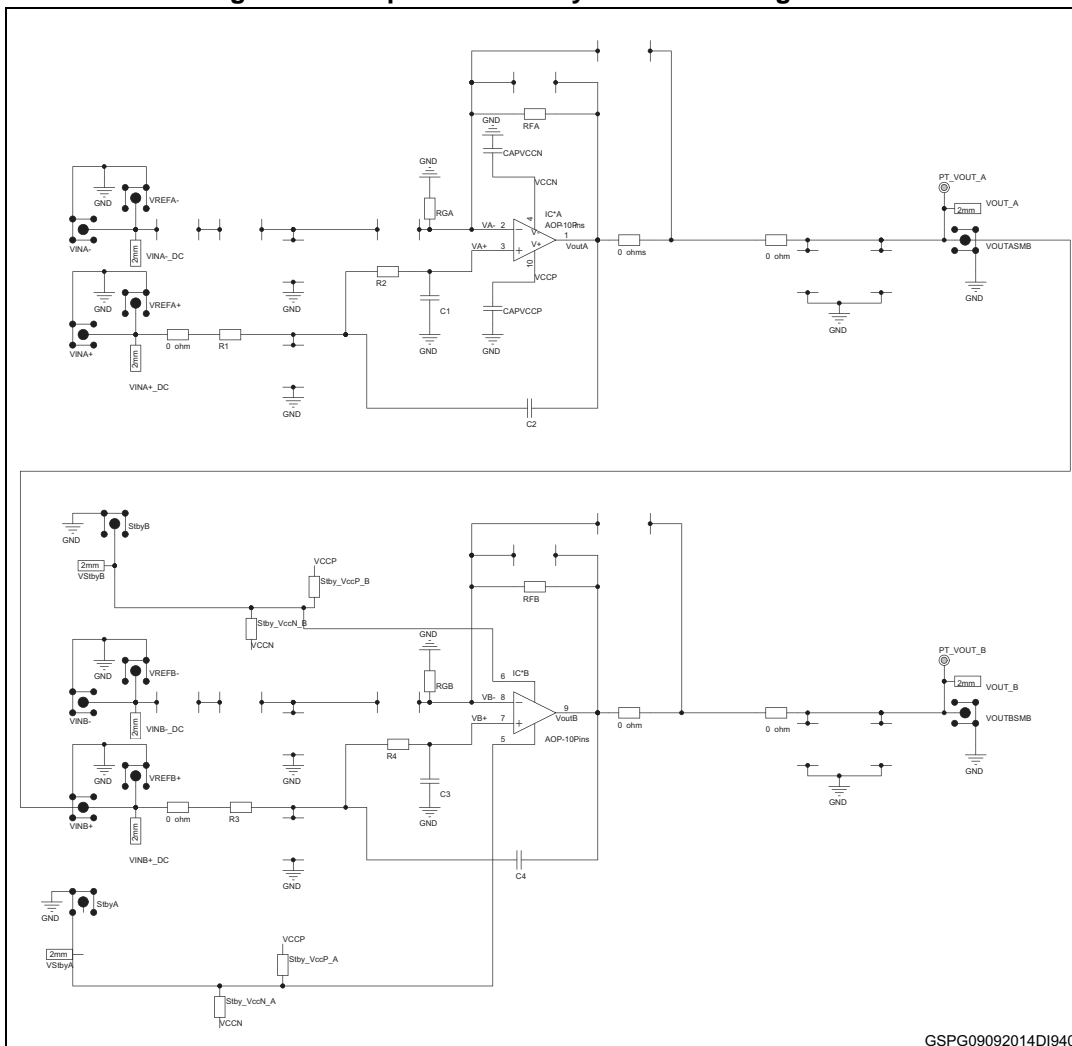

GSPG09092014DI940

3.2 High-pass Sallen-key configuration

Like the low-pass Sallen-key configuration above, this one is also a fourth order. It has a slope of +80 dB per decade.

The transfer function is:

Equation 3

$$\frac{V_{out}}{V_{in}} = \frac{\left(1 + \frac{RFA}{RGA}\right) \cdot R1 \cdot R2 \cdot C1 \cdot C2 \cdot (j\omega)^2}{1 + \left(R2(C1 + C2) - R1 \cdot C2 \cdot \frac{RFA}{RGA}\right) j\omega + R1 \cdot R2 \cdot C1 \cdot C2 (j\omega)^2} * \frac{\left(1 + \frac{RFB}{RGB}\right) \cdot R3 \cdot R4 \cdot C3 \cdot C4 \cdot (j\omega)^2}{1 + \left(R4(C3 + C4) - R3 \cdot C4 \cdot \frac{RFB}{RGB}\right) j\omega + R3 \cdot R4 \cdot C3 \cdot C4 (j\omega)^2}$$

The high frequency gain is:

Equation 4

$$G = \left(1 + \frac{RFA}{RGA}\right) * \left(1 + \frac{RFB}{RGB}\right)$$

Figure 7. High-pass Sallen-key configuration

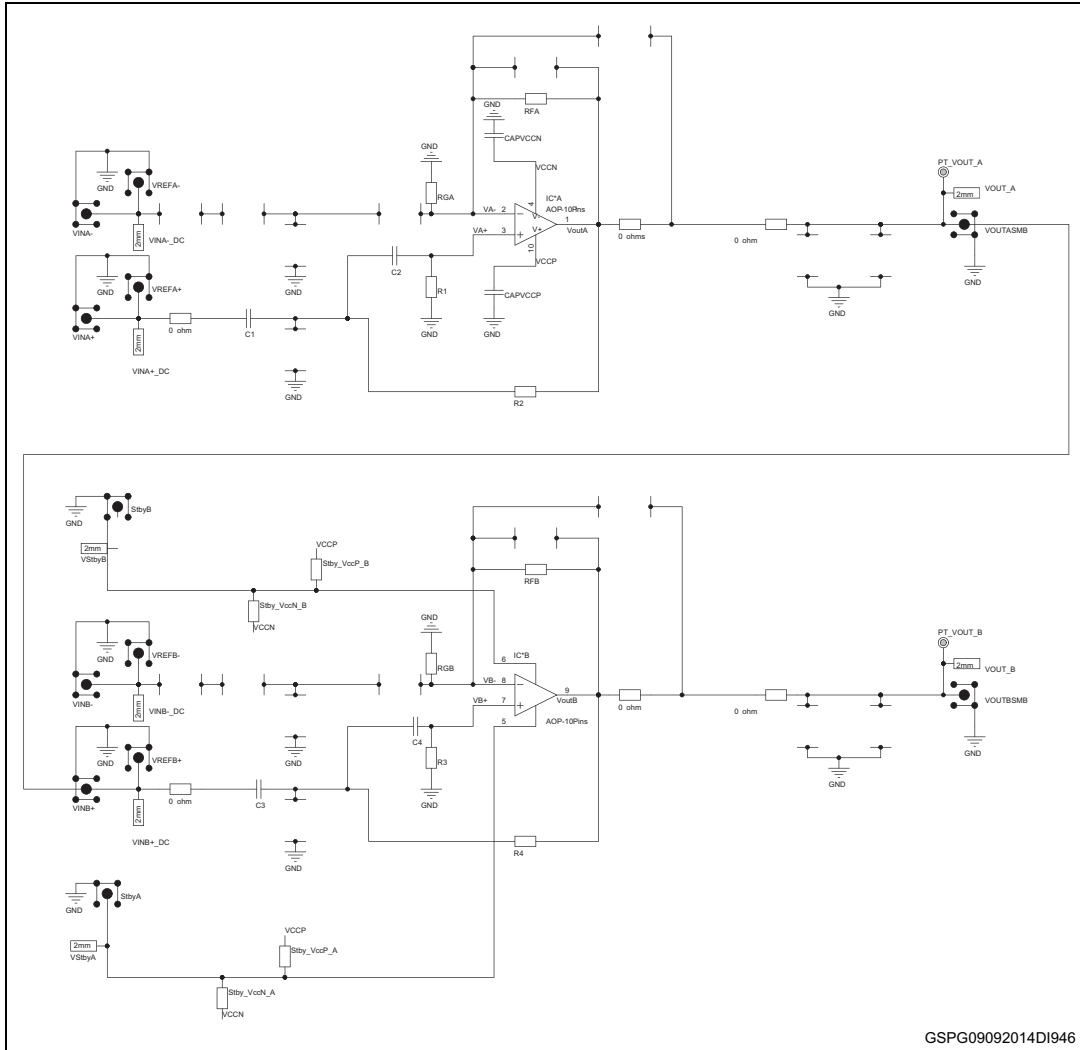

GSPG09092014DI946

The upper limit of the frequency range is determined by the GBP of the op amp ($f \ll \frac{GBP}{R_F}$)

3.3 Instrumentation amplifier

The instrumentation amplifiers are generally used for precise measurement in a differential way.

The architecture of the instrumentation amplifier with dual op amps is the simplest one. The input impedance is high as the non-inverting of the both op amps are used as input.

By considering $R1.R2 = RFA.RFB$

And $Vout = Vreference$ for $Vdiff = 0 V$

The gain can be expressed as follows:

Equation 5

$$G = 1 + \frac{RFB}{Rg} + \frac{R1}{Rg} + \frac{R1}{RFA}$$

Figure 8. Instrumentation amplifier

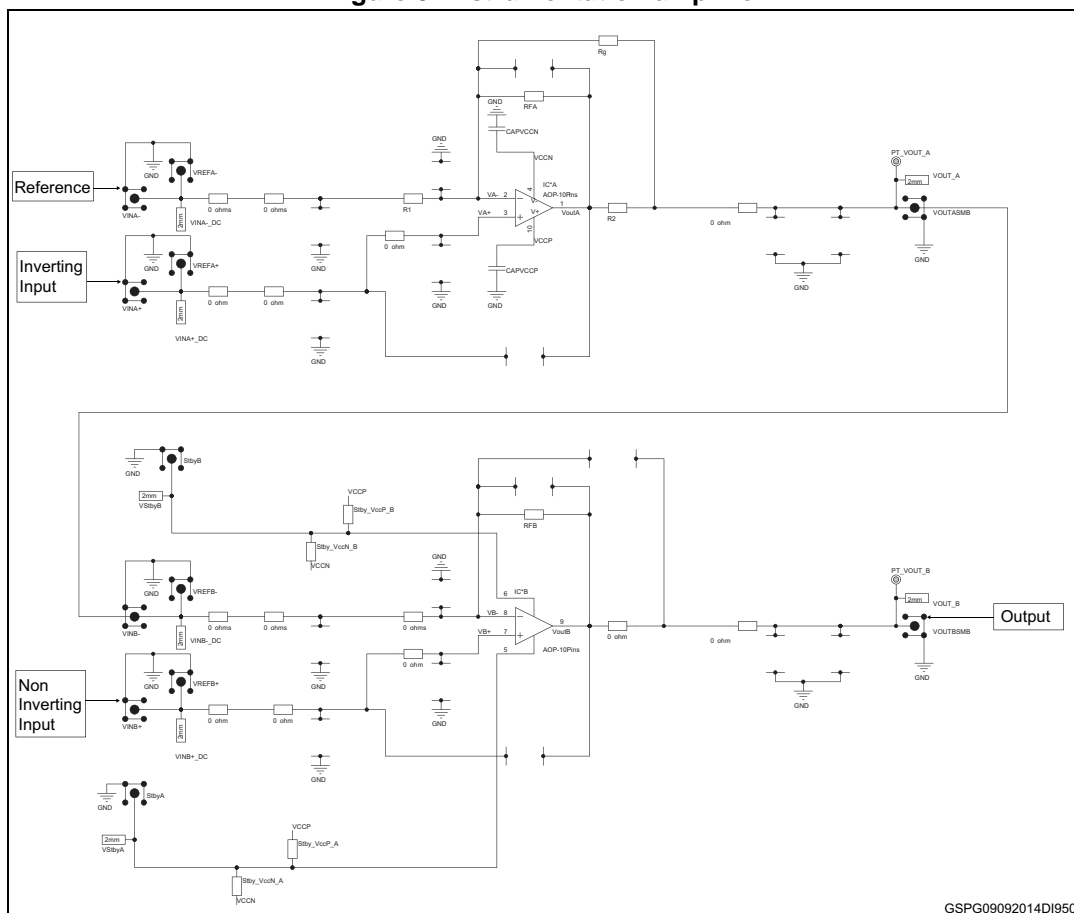

3.4 Transimpedance configuration

The [Figure 9](#) shows how to configure op amp IC1A as a transimpedance amplifier (TIA). The output voltage of the TIA is the input current multiplied by the feedback resistor RFA:

Equation 6

$$VOUT_A = (I_{in} + I_{bias}) * RFA - V_{os}$$

where I_{in} is defined as the input current source applied at the VINA- pad, I_{BIAS} is the input bias current, and V_{OS} is the input offset voltage of the op amp. For the type of usage, the feedback resistor RFA is generally high and the impedance seen on the VA- node is pretty capacitive (ex: photodiode). In order to stabilize the op amp it is recommended to connect a feedback capacitance CF.

Figure 9. Transimpedance configuration

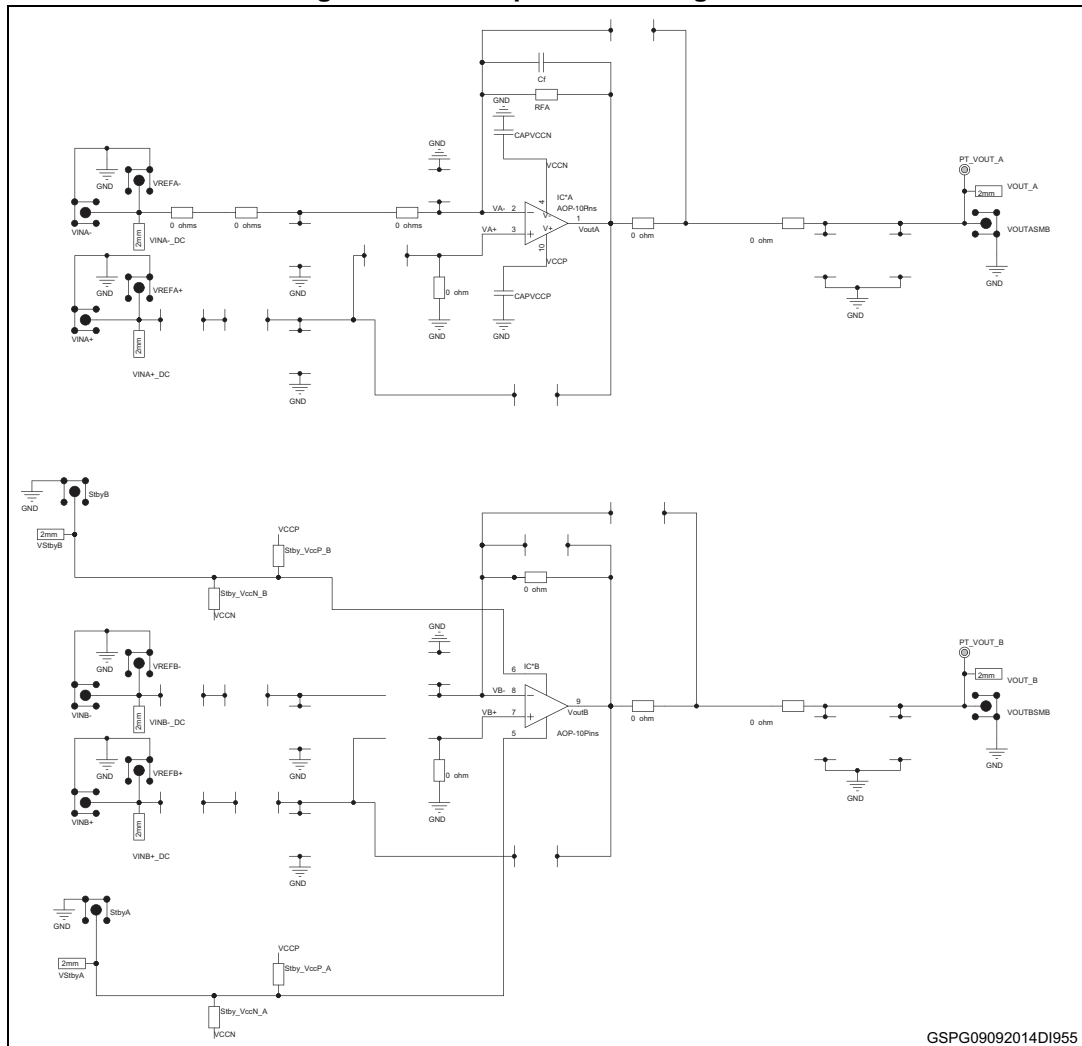

GSPG09092014DI955

Note: *If only IC1A opamp is used as transimpedance amplifier, the second one IC1B should be configure in follower mode in order to avoid any undesired oscillation on its output.*

3.5 AC coupled circuit configuration

This typical configuration allows you to amplify the AC part only of the input signal. As for example typical stereo audio amplifier.

Figure 10. AC coupled circuit configuration

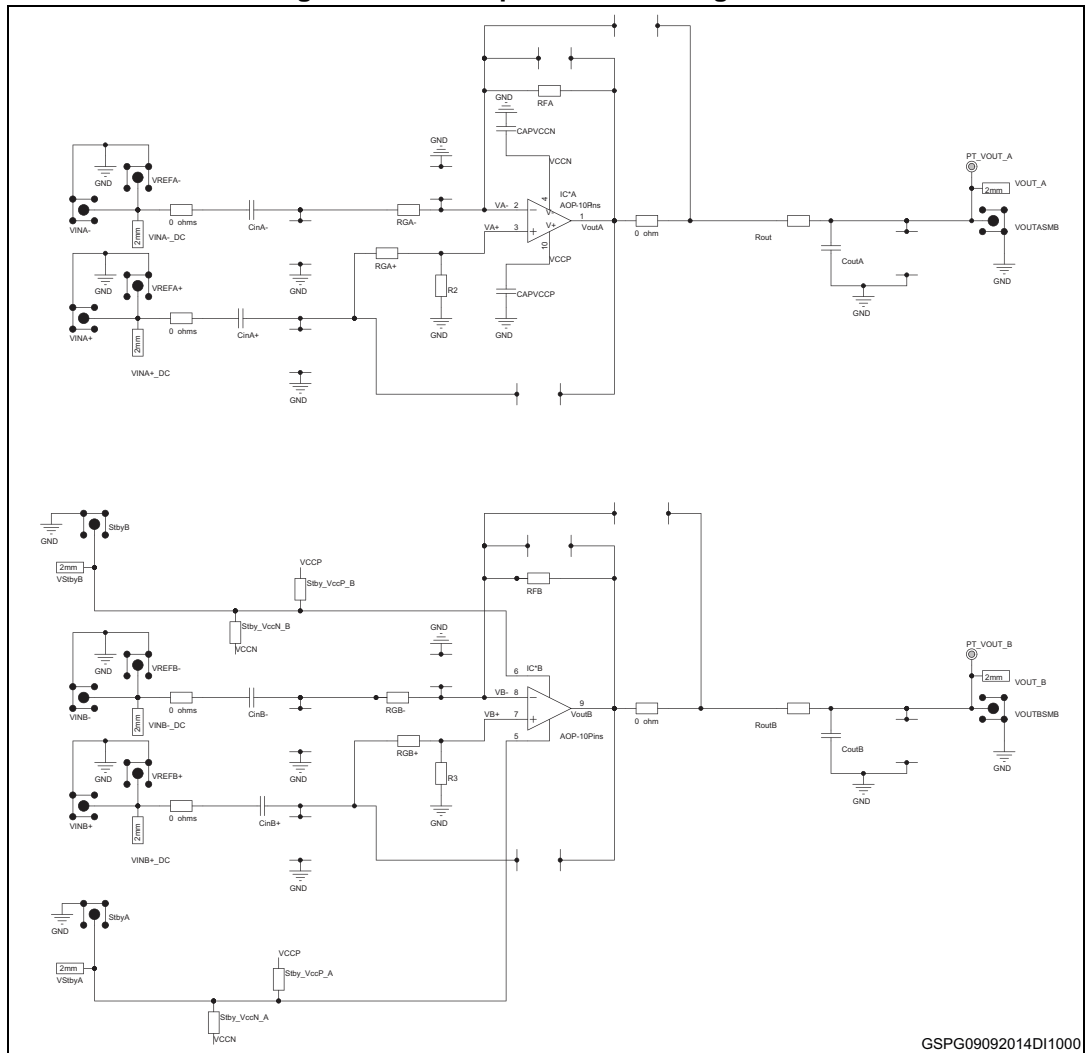

GSPG09092014DI1000

4 Associated products

Table 1. Associated products

Part number	General description
LMV823IST	Low power, high accuracy, general purpose operational amplifier
LMV823AIST	Low power, high accuracy, general purpose operational amplifier
TSV623IST	Micro-power CMOS op-amp with standby
TSV623AIST	Micro-power CMOS op-amp with standby
TSV6293IST	Micro-power CMOS op-amp with standby
TSV6293AIST	Micro-power CMOS op-amp
TSV633IST	Micro-power CMOS op-amp with standby
TSV633AIST	Micro-power CMOS op-amp with standby
TSV6393IST	Micro-power CMOS op-amp with standby
TSV6393AIST	Micro-power CMOS op-amp with standby
TSV853IST	Low-power, high accuracy, general-purpose operational amplifier
TSV853AIST	Low-power, high accuracy, general-purpose operational amplifier
TSX923IST	10MHz, rail-to-rail 16V CMOS op-amps with standby

5 Revision history

Table 2. Document revision history

Date	Revision	Changes
11-Sep-2014	1	Initial release.

IMPORTANT NOTICE – PLEASE READ CAREFULLY

STMicroelectronics NV and its subsidiaries ("ST") reserve the right to make changes, corrections, enhancements, modifications, and improvements to ST products and/or to this document at any time without notice. Purchasers should obtain the latest relevant information on ST products before placing orders. ST products are sold pursuant to ST's terms and conditions of sale in place at the time of order acknowledgement.

Purchasers are solely responsible for the choice, selection, and use of ST products and ST assumes no liability for application assistance or the design of Purchasers' products.

No license, express or implied, to any intellectual property right is granted by ST herein.

Resale of ST products with provisions different from the information set forth herein shall void any warranty granted by ST for such product.

ST and the ST logo are trademarks of ST. All other product or service names are the property of their respective owners.

Information in this document supersedes and replaces information previously supplied in any prior versions of this document.

© 2014 STMicroelectronics – All rights reserved

