

# MC74HC4316A

## Product Preview

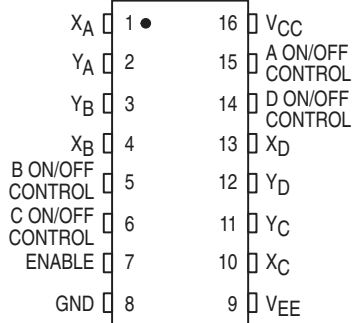
# Quad Analog Switch/ Multiplexer/Demultiplexer with Separate Analog and Digital Power Supplies High-Performance Silicon-Gate CMOS

The MC74HC4316A utilizes silicon-gate CMOS technology to achieve fast propagation delays, low ON resistances, and low OFF-channel leakage current. This bilateral switch/multiplexer/demultiplexer controls analog and digital voltages that may vary across the full analog power-supply range (from  $V_{CC}$  to  $V_{EE}$ ).

The HC4316A is similar in function to the metal-gate CMOS MC14016 and MC14066, and to the High-Speed CMOS HC4066A. Each device has four independent switches. The device control and Enable inputs are compatible with standard CMOS outputs; with pullup resistors, they are compatible with LSTTL outputs. The device has been designed so that the ON resistances ( $R_{ON}$ ) are much more linear over input voltage than  $R_{ON}$  of metal-gate CMOS analog switches. Logic-level translators are provided so that the On/Off Control and Enable logic-level voltages need only be  $V_{CC}$  and GND, while the switch is passing signals ranging between  $V_{CC}$  and  $V_{EE}$ . When the Enable pin (active-low) is high, all four analog switches are turned off.

- Logic-Level Translator for On/Off Control and Enable Inputs
- Fast Switching and Propagation Speeds
- High ON/OFF Output Voltage Ratio
- Diode Protection on All Inputs/Outputs
- Analog Power-Supply Voltage Range ( $V_{CC} - V_{EE}$ ) = 2.0 to 12.0 Volts
- Digital (Control) Power-Supply Voltage Range ( $V_{CC} - GND$ ) = 2.0 to 6.0 Volts, Independent of  $V_{EE}$
- Improved Linearity of ON Resistance
- Chip Complexity: 66 FETs or 16.5 Equivalent Gates

### PIN ASSIGNMENT



### FUNCTION TABLE

Inputs		State of Analog Switch
Enable	On/Off Control	
L	H	On
L	L	Off
H	X	Off

X = don't care

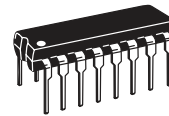
This document contains information on a product under development. ON Semiconductor reserves the right to change or discontinue this product without notice.



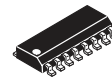
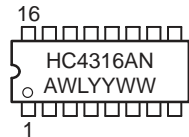
ON Semiconductor

<http://onsemi.com>

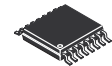
### MARKING DIAGRAMS



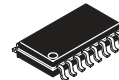
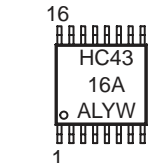
PDIP-16  
N SUFFIX  
CASE 648



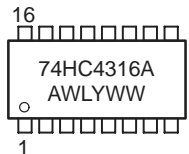
SOIC-16  
D SUFFIX  
CASE 751B



TSSOP-16  
DT SUFFIX  
CASE 948F



SOEIAJ-16  
F SUFFIX  
CASE 966



A = Assembly Location  
WL or L = Wafer Lot  
YY or Y = Year  
WW or W = Work Week

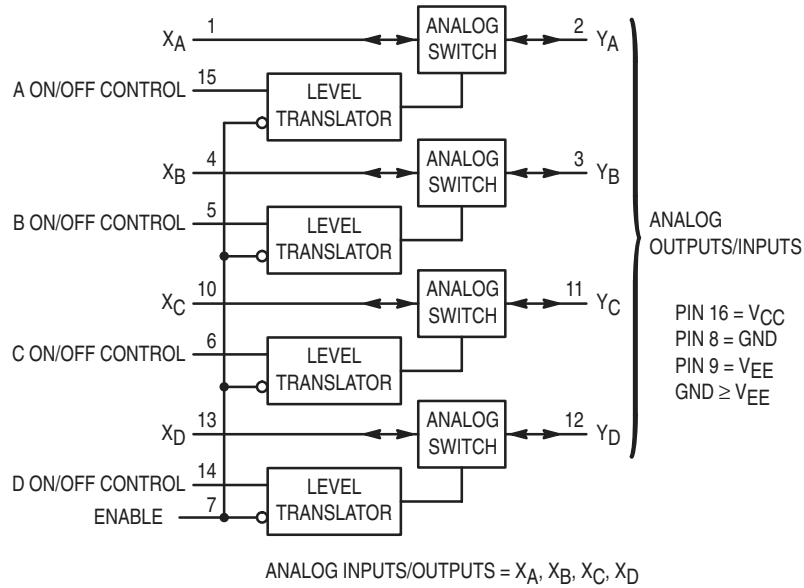
### ORDERING INFORMATION

Device	Package	Shipping
MC74HC4316AN	PDIP-16	2000 / Box
MC74HC4316AD	SOIC-16	48 / Rail
MC74HC4316ADR2	SOIC-16	2500 / Reel
MC74HC4316ADT	TSSOP-16	96 / Rail
MC74HC4316ADTR2	TSSOP-16	2500 / Reel
MC74HC4316AF	SOEIAJ-14	See Note 1.

1. For ordering information on the EIAJ version of the SOIC packages, please contact your local ON Semiconductor representative.

# MC74HC4316A

## LOGIC DIAGRAM



## MAXIMUM RATINGS\*

Symbol	Parameter	Value	Unit
$V_{CC}$	Positive DC Supply Voltage (Ref. to GND) (Ref. to $V_{EE}$ )	- 0.5 to + 7.0 - 0.5 to + 14.0	V
$V_{EE}$	Negative DC Supply Voltage (Ref. to GND)	- 7.0 to + 0.5	V
$V_{IS}$	Analog Input Voltage	$V_{EE} - 0.5$ to $V_{CC} + 0.5$	V
$V_{in}$	DC Input Voltage (Ref. to GND)	- 0.5 to $V_{CC} + 0.5$	V
I	DC Current Into or Out of Any Pin	$\pm 25$	mA
$P_D$	Power Dissipation in Still Air	Plastic DIP† 750 EIAJ/SOIC Package† 500 TSSOP Package† 450	mW
$T_{stg}$	Storage Temperature	- 65 to + 150	$^{\circ}C$
$T_L$	Lead Temperature, 1 mm from Case for 10 Seconds (Plastic DIP, SOIC or TSSOP Package)	260	$^{\circ}C$

This device contains protection circuitry to guard against damage due to high static voltages or electric fields. However, precautions must be taken to avoid applications of any voltage higher than maximum rated voltages to this high-impedance circuit. For proper operation,  $V_{in}$  and  $V_{out}$  should be constrained to the range  $GND \leq (V_{in} \text{ or } V_{out}) \leq V_{CC}$ . Unused inputs must always be tied to an appropriate logic voltage level (e.g., either GND or  $V_{CC}$ ). Unused outputs must be left open. I/O pins must be connected to a properly terminated line or bus.

\*Maximum Ratings are those values beyond which damage to the device may occur.

Functional operation should be restricted to the Recommended Operating Conditions.

†Derating — Plastic DIP: - 10 mW/ $^{\circ}C$  from 65 $^{\circ}$  to 125 $^{\circ}C$

EIAJ/SOIC Package: - 7 mW/ $^{\circ}C$  from 65 $^{\circ}$  to 125 $^{\circ}C$

TSSOP Package: - 6.1 mW/ $^{\circ}C$  from 65 $^{\circ}$  to 125 $^{\circ}C$

For high frequency or heavy load considerations, see Chapter 2 of the ON Semiconductor High-Speed CMOS Data Book (DL129/D).

# MC74HC4316A

## RECOMMENDED OPERATING CONDITIONS

Symbol	Parameter	Min	Max	Unit	
V <sub>CC</sub>	Positive DC Supply Voltage (Ref. to GND)	2.0	6.0	V	
V <sub>EE</sub>	Negative DC Supply Voltage (Ref. to GND)	-6.0	GND	V	
V <sub>IS</sub>	Analog Input Voltage	V <sub>EE</sub>	V <sub>CC</sub>	V	
V <sub>in</sub>	Digital Input Voltage (Ref. to GND)	GND	V <sub>CC</sub>	V	
V <sub>IO</sub> *	Static or Dynamic Voltage Across Switch	—	1.2	V	
T <sub>A</sub>	Operating Temperature, All Package Types	-55	+125	°C	
t <sub>r</sub> , t <sub>f</sub>	Input Rise and Fall Time (Control or Enable Inputs) (Figure 10)	V <sub>CC</sub> = 2.0 V V <sub>CC</sub> = 3.0 V V <sub>CC</sub> = 4.5 V V <sub>CC</sub> = 6.0 V	0 0 0 0	1000 600 500 400	ns

\*For voltage drops across the switch greater than 1.2 V (switch on), excessive V<sub>CC</sub> current may be drawn; i.e., the current out of the switch may contain both V<sub>CC</sub> and switch input components. The reliability of the device will be unaffected unless the Maximum Ratings are exceeded.

## DC ELECTRICAL CHARACTERISTICS Digital Section (Voltages Referenced to GND) V<sub>EE</sub> = GND Except Where Noted

Symbol	Parameter	Test Conditions	V <sub>CC</sub> V	Guaranteed Limit			Unit
				-55 to 25°C	≤ 85°C	≤ 125°C	
V <sub>IH</sub>	Minimum High-Level Voltage, Control or Enable Inputs	R <sub>on</sub> = Per Spec	2.0	1.5	1.5	1.5	V
			3.0	2.1	2.1	2.1	
			4.5	3.15	3.15	3.15	
			6.0	4.2	4.2	4.2	
V <sub>IL</sub>	Maximum Low-Level Voltage, Control or Enable Inputs	R <sub>on</sub> = Per Spec	2.0	0.5	0.5	0.5	V
			3.0	0.9	0.9	0.9	
			4.5	1.35	1.35	1.35	
			6.0	1.8	1.8	1.8	
I <sub>in</sub>	Maximum Input Leakage Current, Control or Enable Inputs	V <sub>in</sub> = V <sub>CC</sub> or GND V <sub>EE</sub> = -6.0 V	6.0	±0.1	±1.0	±1.0	μA
I <sub>CC</sub>	Maximum Quiescent Supply Current (per Package)	V <sub>in</sub> = V <sub>CC</sub> or GND V <sub>IO</sub> = 0 V V <sub>EE</sub> = GND V <sub>EE</sub> = -6.0	6.0	2	20	40	μA
			6.0	4	40	160	

NOTE: Information on typical parametric values can be found in Chapter 2 of the ON Semiconductor High-Speed CMOS Data Book (DL129/D).

# MC74HC4316A

## DC ELECTRICAL CHARACTERISTICS Analog Section (Voltages Referenced to $V_{EE}$ )

Symbol	Parameter	Test Conditions	$V_{CC}$ V	$V_{EE}$ V	Guaranteed Limit			Unit
					- 55 to 25°C	≤ 85°C	≤ 125°C	
$R_{on}$	Maximum "ON" Resistance	$V_{in} = V_{IH}$ $V_{IS} = V_{CC}$ to $V_{EE}$ $I_S \leq 2.0$ mA (Figures 1, 2)	2.0*	0.0	—	—	—	$\Omega$
			4.5	0.0	160	200	240	
			4.5	- 4.5	90	110	130	
			6.0	- 6.0	90	110	130	
		$V_{in} = V_{IH}$ $V_{IS} = V_{CC}$ or $V_{EE}$ (Endpoints) $I_S \leq 2.0$ mA (Figures 1, 2)	2.0	0.0	—	—	—	
			4.5	0.0	90	115	140	
			4.5	- 4.5	70	90	105	
			6.0	- 6.0	70	90	105	
$\Delta R_{on}$	Maximum Difference in "ON" Resistance Between Any Two Channels in the Same Package	$V_{in} = V_{IH}$ $V_{IS} = 1/2 (V_{CC} - V_{EE})$ $I_S \leq 2.0$ mA	2.0	0.0	—	—	—	$\Omega$
			4.5	0.0	20	25	30	
			4.5	- 4.5	15	20	25	
			6.0	- 6.0	15	20	25	
$I_{off}$	Maximum Off-Channel Leakage Current, Any One Channel	$V_{in} = V_{IL}$ $V_{IO} = V_{CC}$ or $V_{EE}$ Switch Off (Figure 3)	6.0	- 6.0	0.1	0.5	1.0	$\mu$ A
$I_{on}$	Maximum On-Channel Leakage Current, Any One Channel	$V_{in} = V_{IH}$ $V_{IS} = V_{CC}$ or $V_{EE}$ (Figure 4)	6.0	- 6.0	0.1	0.5	1.0	$\mu$ A

\*At supply voltage ( $V_{CC} - V_{EE}$ ) approaching 2 V the analog switch-on resistance becomes extremely non-linear. Therefore, for low-voltage operation, it is recommended that these devices only be used to control digital signals.

NOTE: Information on typical parametric values can be found in Chapter 2 of the ON Semiconductor High-Speed CMOS Data Book (DL129/D).

## AC ELECTRICAL CHARACTERISTICS ( $C_L = 50$ pF, Control or Enable $t_r = t_f = 6$ ns, $V_{EE} = GND$ )

Symbol	Parameter	$V_{CC}$ V	Guaranteed Limit			Unit		
			- 55 to 25°C	≤ 85°C	≤ 125°C			
$t_{PLH}$ , $t_{PHL}$	Maximum Propagation Delay, Analog Input to Analog Output (Figures 8 and 9)	2.0	40	50	60	ns		
		4.5	6	8	9			
		6.0	5	7	8			
$t_{PLZ}$ , $t_{PHZ}$	Maximum Propagation Delay, Control or Enable to Analog Output (Figures 10 and 11)	2.0	130	160	200	ns		
		4.5	40	50	60			
		6.0	30	40	50			
$t_{PZL}$ , $t_{PZH}$	Maximum Propagation Delay, Control or Enable to Analog Output (Figures 10 and 11)	2.0	140	175	250	ns		
		4.5	40	50	60			
		6.0	30	40	50			
C	Maximum Capacitance	ON/OFF Control and Enable Inputs	—	10	10	10	pF	
			Control Input = GND	—	35	35		35
				Analog I/O Feedthrough	—	1.0		1.0

### NOTES:

- For propagation delays with loads other than 50 pF, see Chapter 2 of the ON Semiconductor High-Speed CMOS Data Book (DL129/D).
- Information on typical parametric values can be found in Chapter 2 of the ON Semiconductor High-Speed CMOS Data Book (DL129/D).

$C_{PD}$	Power Dissipation Capacitance (Per Switch) (Figure 13)*	Typical @ 25°C, $V_{CC} = 5.0$ V	
		15	pF

\* Used to determine the no-load dynamic power consumption:  $P_D = C_{PD} V_{CC}^2 f + I_{CC} V_{CC}$ . For load considerations, see Chapter 2 of the ON Semiconductor High-Speed CMOS Data Book (DL129/D).

# MC74HC4316A

## ADDITIONAL APPLICATION CHARACTERISTICS (GND = 0 V)

Symbol	Parameter	Test Conditions	VCC V	VEE V	Limit* 25°C	Unit
BW	Maximum On-Channel Bandwidth or Minimum Frequency Response (Figure 5)	$f_{in} = 1$ MHz Sine Wave Adjust $f_{in}$ Voltage to Obtain 0 dBm at $V_{OS}$ Increase $f_{in}$ Frequency Until dB Meter Reads -3 dB $R_L = 50 \Omega$ , $C_L = 10$ pF	2.25 4.50 6.00	-2.25 -4.50 -6.00	150 160 160	MHz
—	Off-Channel Feedthrough Isolation (Figure 6)	$f_{in} \equiv$ Sine Wave Adjust $f_{in}$ Voltage to Obtain 0 dBm at $V_{IS}$ $f_{in} = 10$ kHz, $R_L = 600 \Omega$ , $C_L = 50$ pF  $f_{in} = 1.0$ MHz, $R_L = 50 \Omega$ , $C_L = 10$ pF	2.25 4.50 6.00  2.25 4.50 6.00	-2.25 -4.50 -6.00  -2.25 -4.50 -6.00	-50 -50 -50  -40 -40 -40	dB
—	Feedthrough Noise, Control to Switch (Figure 7)	$V_{in} \leq 1$ MHz Square Wave ( $t_r = t_f = 6$ ns) Adjust $R_L$ at Setup so that $I_S = 0$ A $R_L = 600 \Omega$ , $C_L = 50$ pF  $R_L = 10$ k $\Omega$ , $C_L = 10$ pF	2.25 4.50 6.00  2.25 4.50 6.00	-2.25 -4.50 -6.00  -2.25 -4.50 -6.00	60 130 200  30 65 100	mVpp
—	Crosstalk Between Any Two Switches (Figure 12)	$f_{in} \equiv$ Sine Wave Adjust $f_{in}$ Voltage to Obtain 0 dBm at $V_{IS}$ $f_{in} = 10$ kHz, $R_L = 600 \Omega$ , $C_L = 50$ pF  $f_{in} = 1.0$ MHz, $R_L = 50 \Omega$ , $C_L = 10$ pF	2.25 4.50 6.00  2.25 4.50 6.00	-2.25 -4.50 -6.00  -2.25 -4.50 -6.00	-70 -70 -70  -80 -80 -80	dB
THD	Total Harmonic Distortion (Figure 14)	$f_{in} = 1$ kHz, $R_L = 10$ k $\Omega$ , $C_L = 50$ pF THD = THD <sub>Measured</sub> - THD <sub>Source</sub> $V_{IS} = 4.0$ Vpp sine wave $V_{IS} = 8.0$ Vpp sine wave $V_{IS} = 11.0$ Vpp sine wave	2.25 4.50 6.00	-2.25 -4.50 -6.00	0.10 0.06 0.04	%

\*Limits not tested. Determined by design and verified by qualification.

# MC74HC4316A

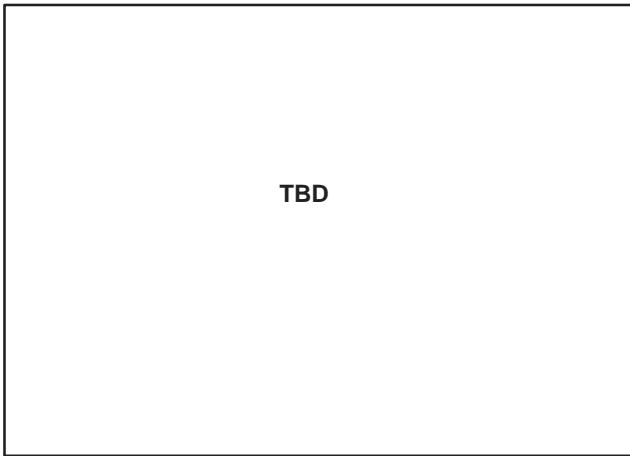


Figure 1a. Typical On Resistance,  
 $V_{CC} - V_{EE} = 2.0 \text{ V}$

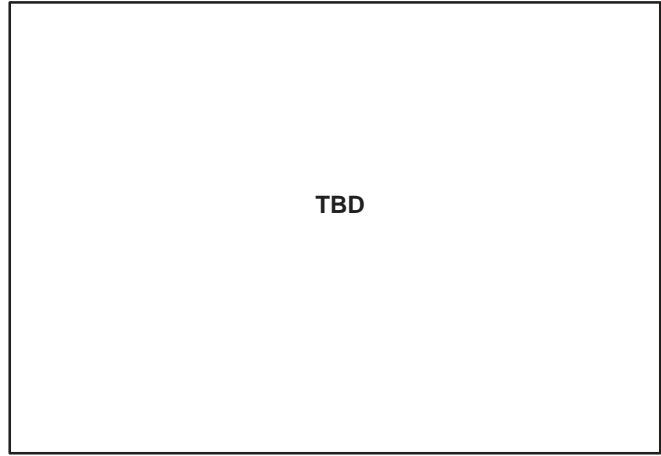


Figure 1b. Typical On Resistance,  
 $V_{CC} - V_{EE} = 4.5 \text{ V}$

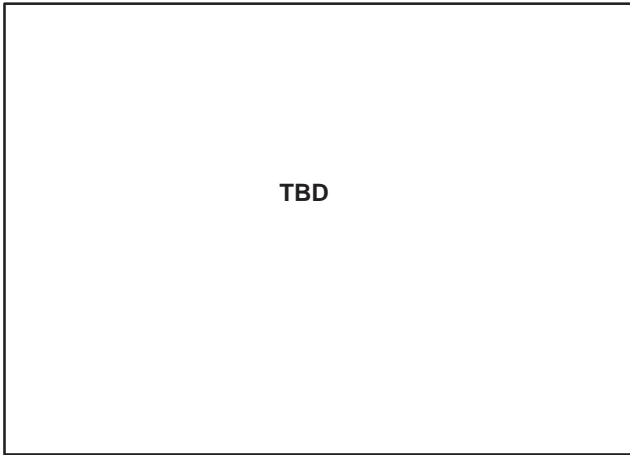


Figure 1c. Typical On Resistance,  
 $V_{CC} - V_{EE} = 6.0 \text{ V}$

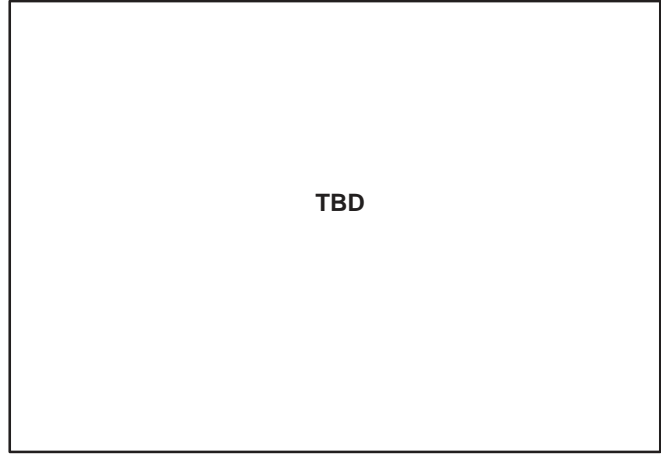


Figure 1d. Typical On Resistance,  
 $V_{CC} - V_{EE} = 9.0 \text{ V}$

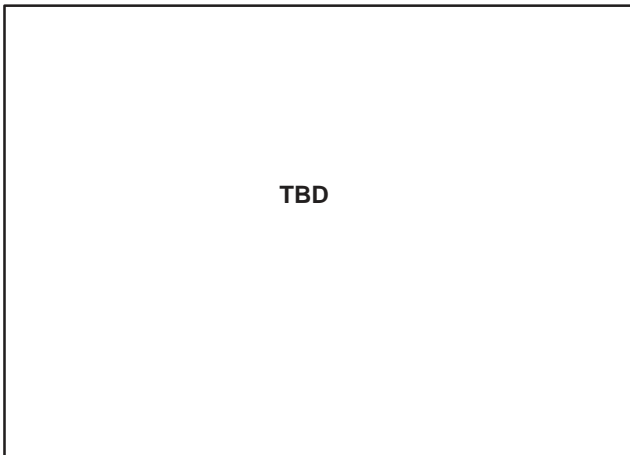


Figure 1e. Typical On Resistance,  
 $V_{CC} - V_{EE} = 12.0 \text{ V}$

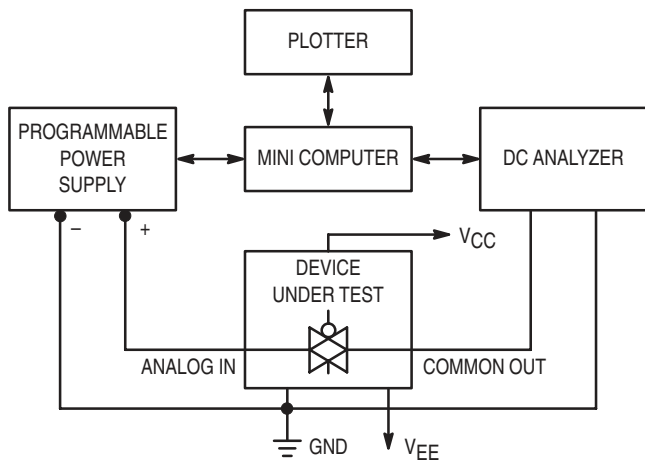
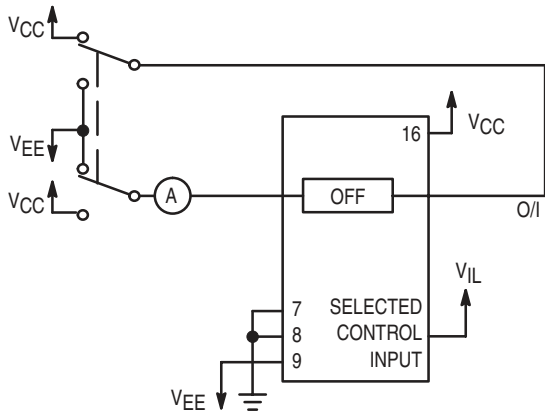
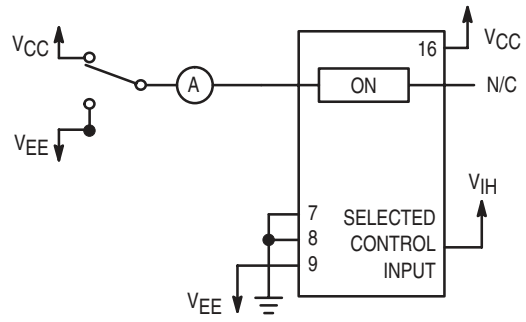


Figure 2. On Resistance Test Set-Up

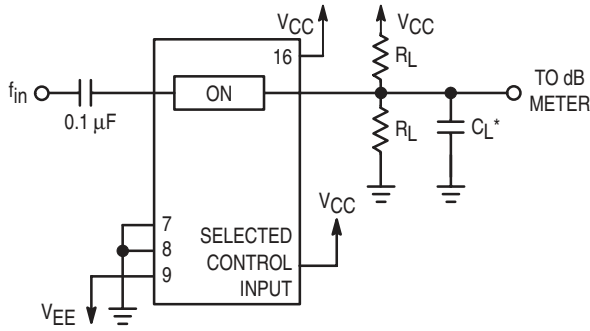
# MC74HC4316A



**Figure 3. Maximum Off Channel Leakage Current, Any One Channel, Test Set-Up**

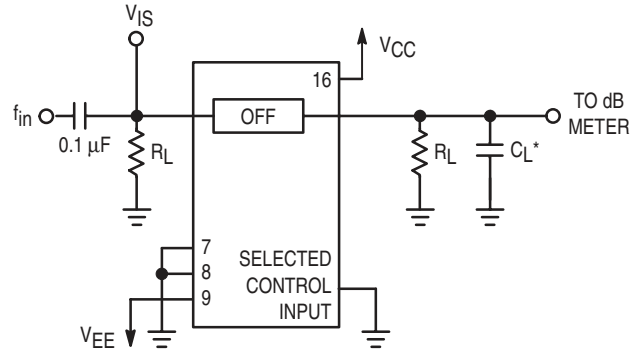


**Figure 4. Maximum On Channel Leakage Current, Test Set-Up**



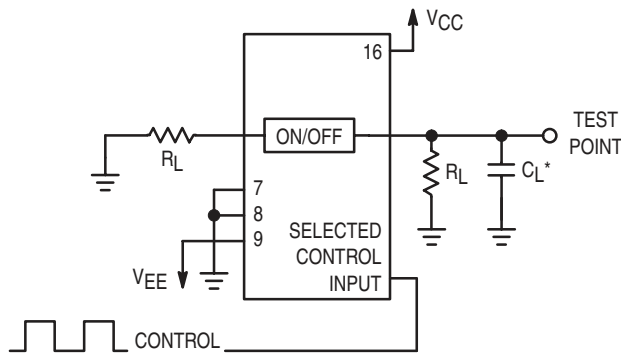
\*Includes all probe and jig capacitance.

**Figure 5. Maximum On-Channel Bandwidth Test Set-Up**



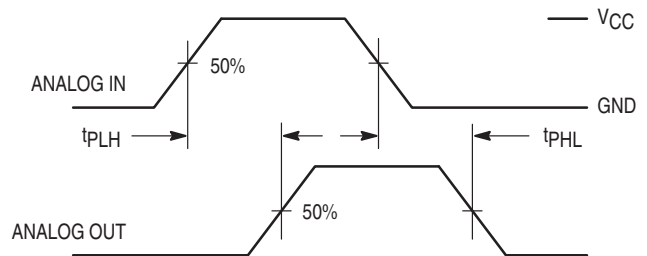
\*Includes all probe and jig capacitance.

**Figure 6. Off-Channel Feedthrough Isolation, Test Set-Up**



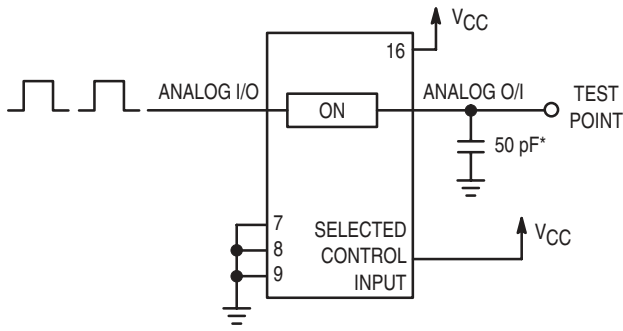
\*Includes all probe and jig capacitance.

**Figure 7. Feedthrough Noise, Control to Analog Out, Test Set-Up**



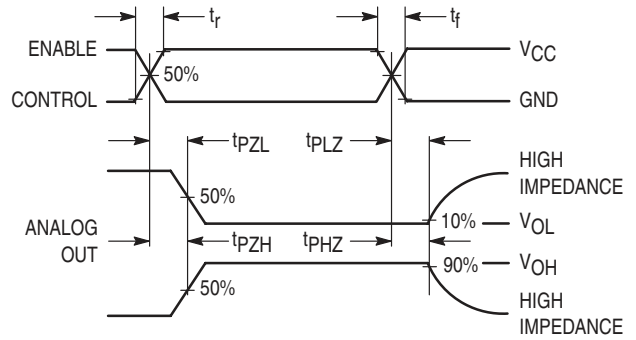
**Figure 8. Propagation Delays, Analog In to Analog Out**

# MC74HC4316A

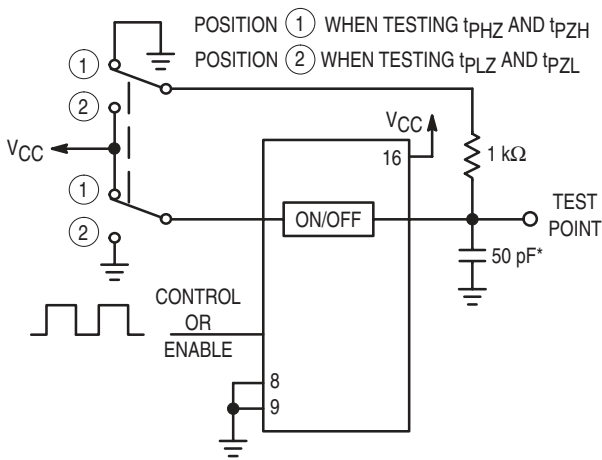


\*Includes all probe and jig capacitance.

**Figure 9. Propagation Delay Test Set-Up**

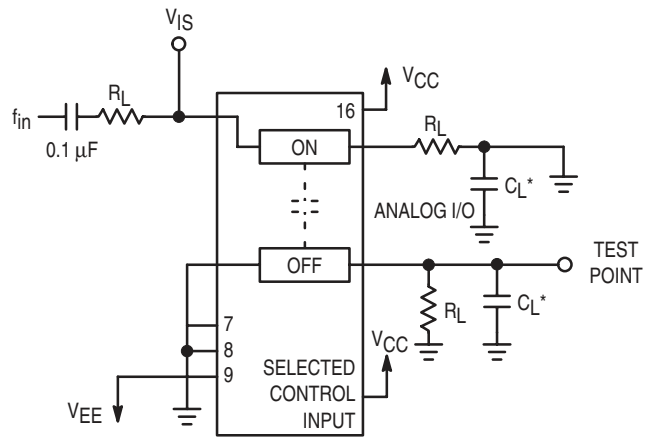


**Figure 10. Propagation Delay, ON/OFF Control to Analog Out**



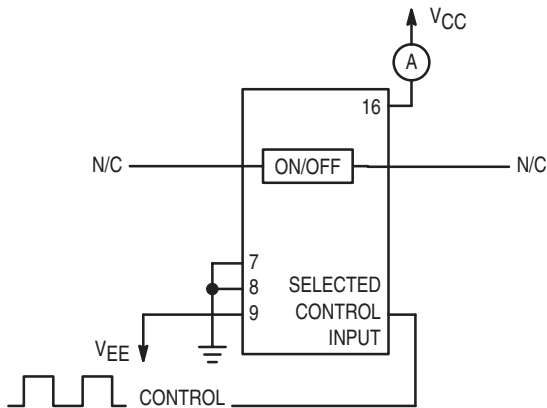
\*Includes all probe and jig capacitance.

**Figure 11. Propagation Delay Test Set-Up**

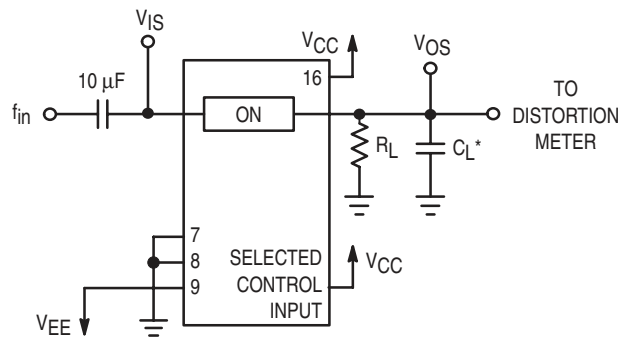


\*Includes all probe and jig capacitance.

**Figure 12. Crosstalk Between Any Two Switches, Test Set-Up (Adjacent Channels Used)**



**Figure 13. Power Dissipation Capacitance Test Set-Up**



\*Includes all probe and jig capacitance.

**Figure 14. Total Harmonic Distortion, Test Set-Up**



APPLICATIONS INFORMATION

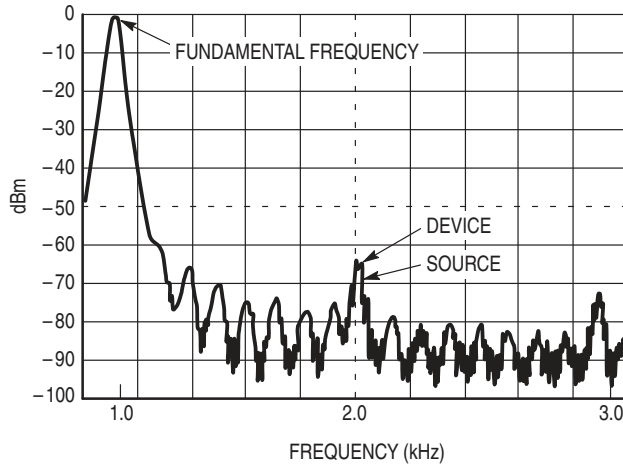


Figure 15. Plot, Harmonic Distortion

The Enable and Control pins should be at  $V_{CC}$  or GND logic levels,  $V_{CC}$  being recognized as logic high and GND being recognized as a logic low. Unused analog inputs/outputs may be left floating (not connected). However, it is advisable to tie unused analog inputs and outputs to  $V_{CC}$  or  $V_{EE}$  through a low value resistor. This minimizes crosstalk and feedthrough noise that may be picked up by the unused I/O pins.

The maximum analog voltage swings are determined by the supply voltages  $V_{CC}$  and  $V_{EE}$ . The positive peak analog voltage should not exceed  $V_{CC}$ . Similarly, the negative peak analog voltage should not go below  $V_{EE}$ . In the example below, the difference between  $V_{CC}$  and  $V_{EE}$  is twelve volts.

Therefore, using the configuration in Figure 16, a maximum analog signal of twelve volts peak-to-peak can be controlled.

When voltage transients above  $V_{CC}$  and/or below  $V_{EE}$  are anticipated on the analog channels, external diodes ( $D_x$ ) are recommended as shown in Figure 17. These diodes should be small signal, fast turn-on types able to absorb the maximum anticipated current surges during clipping. An alternate method would be to replace the  $D_x$  diodes with Mosorb<sup>TM</sup> (Mosorb<sup>TM</sup> is an acronym for high current surge protectors). Mosorb<sup>TM</sup> are fast turn-on devices ideally suited for precise dc protection with no inherent wear out mechanism.

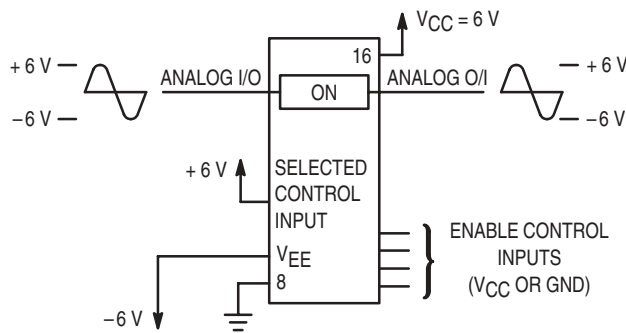


Figure 16.

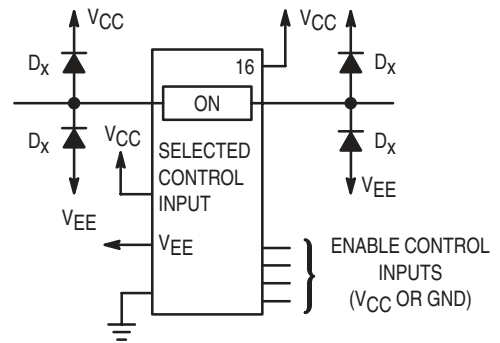


Figure 17. Transient Suppressor Application

# MC74HC4316A

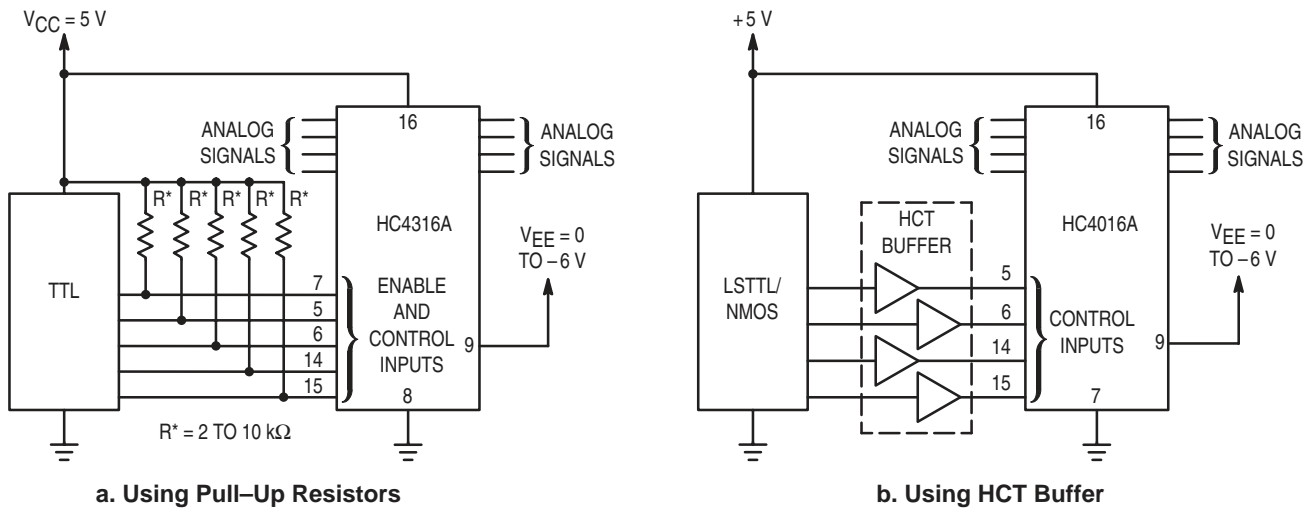


Figure 18. LSTTL/NMOS to HCMOS Interface

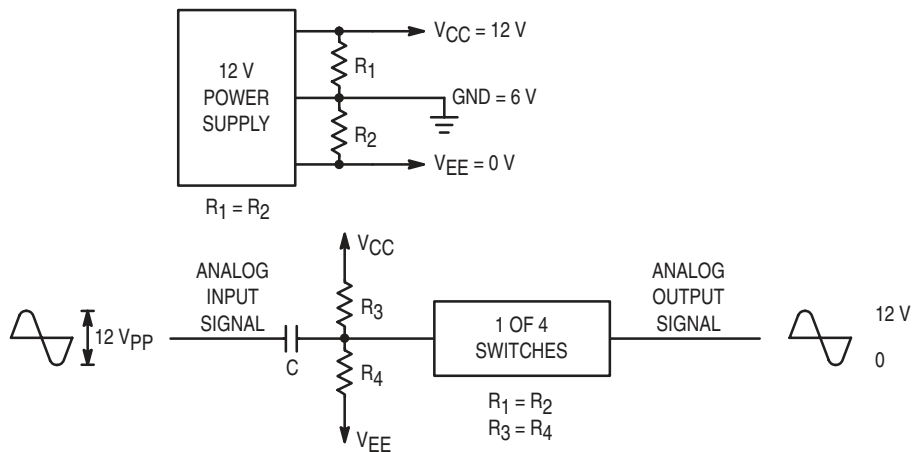


Figure 19. Switching a 0-to-12 V Signal Using a Single Power Supply ( $GND \neq 0V$ )

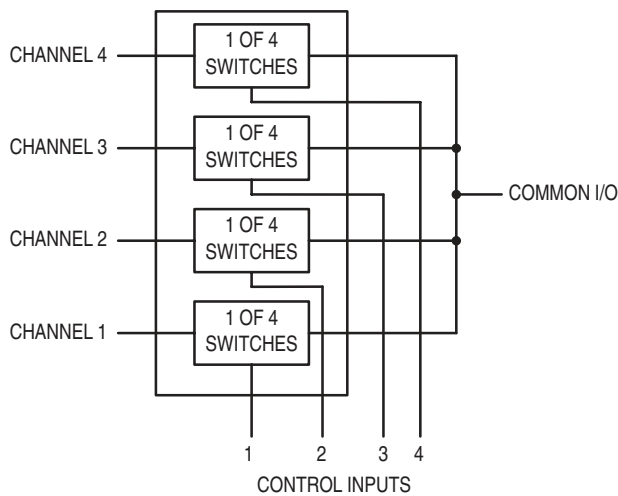


Figure 20. 4-Input Multiplexer

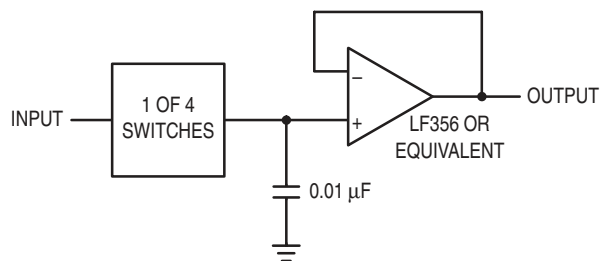
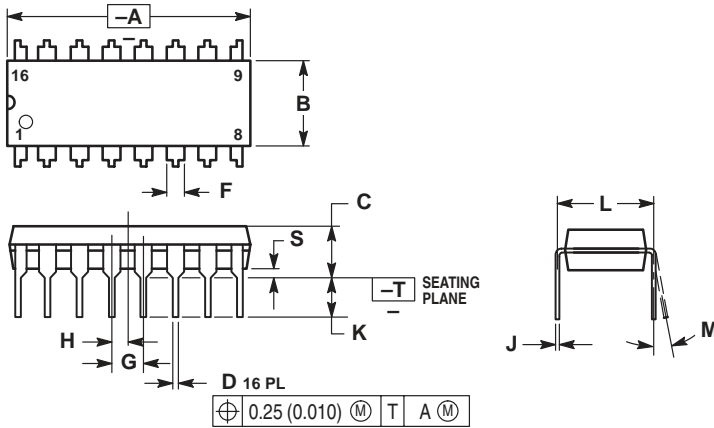


Figure 21. Sample/Hold Amplifier

# MC74HC4316A

## PACKAGE DIMENSIONS

**PDIP-16**  
**N SUFFIX**  
 CASE 648-08  
 ISSUE R

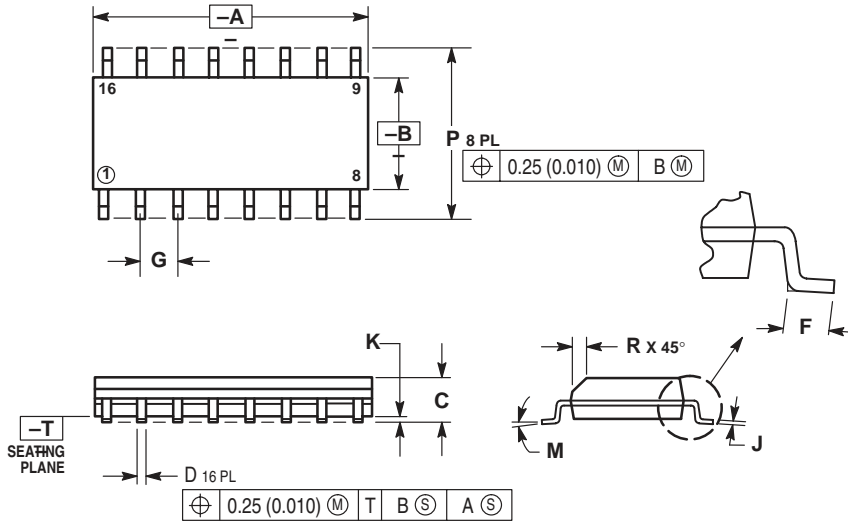


**NOTES:**

1. DIMENSIONING AND TOLERANCING PER ANSI Y14.5M, 1982.
2. CONTROLLING DIMENSION: INCH.
3. DIMENSION L TO CENTER OF LEADS WHEN FORMED PARALLEL.
4. DIMENSION B DOES NOT INCLUDE MOLD FLASH.
5. ROUNDED CORNERS OPTIONAL.

DIM	INCHES		MILLIMETERS	
	MIN	MAX	MIN	MAX
A	0.740	0.770	18.80	19.55
B	0.250	0.270	6.35	6.85
C	0.145	0.175	3.69	4.44
D	0.015	0.021	0.39	0.53
F	0.040	0.070	1.02	1.77
G	0.100 BSC		2.54 BSC	
H	0.050 BSC		1.27 BSC	
J	0.008	0.015	0.21	0.38
K	0.110	0.130	2.80	3.30
L	0.295	0.305	7.50	7.74
M	0°	10°	0°	10°
S	0.020	0.040	0.51	1.01

**SOIC-16**  
**D SUFFIX**  
 CASE 751B-05  
 ISSUE J



**NOTES:**

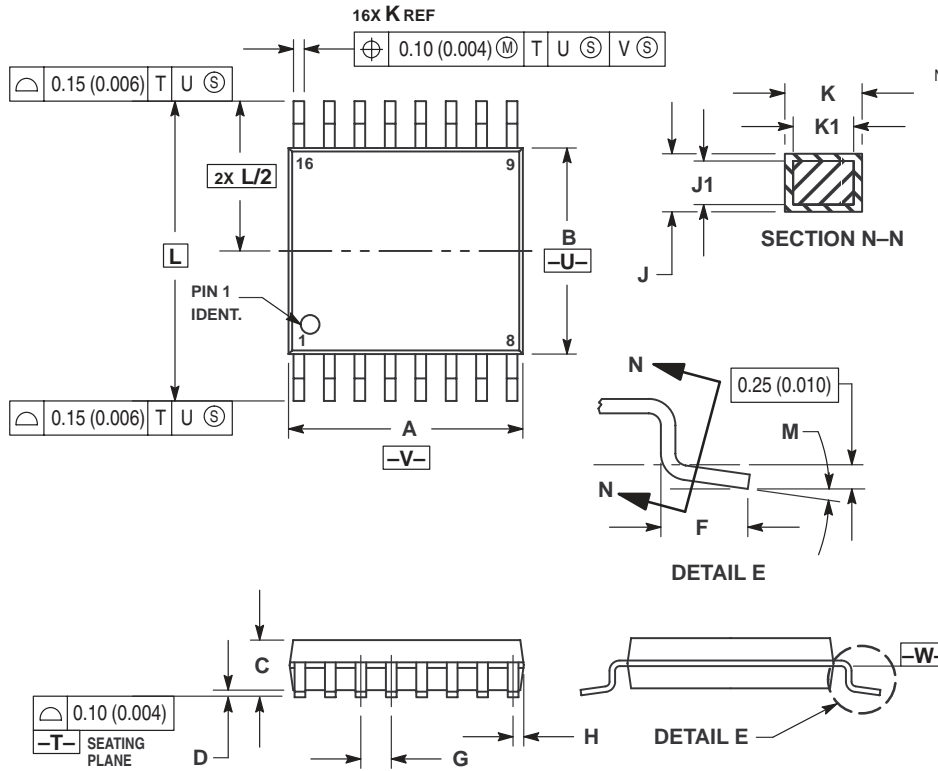
1. DIMENSIONING AND TOLERANCING PER ANSI Y14.5M, 1982.
2. CONTROLLING DIMENSION: MILLIMETER.
3. DIMENSIONS A AND B DO NOT INCLUDE MOLD PROTRUSION.
4. MAXIMUM MOLD PROTRUSION 0.15 (0.006) PER SIDE.
5. DIMENSION D DOES NOT INCLUDE DAMBAR PROTRUSION. ALLOWABLE DAMBAR PROTRUSION SHALL BE 0.127 (0.005) TOTAL IN EXCESS OF THE D DIMENSION AT MAXIMUM MATERIAL CONDITION.

DIM	MILLIMETERS		INCHES	
	MIN	MAX	MIN	MAX
A	9.80	10.00	0.386	0.393
B	3.80	4.00	0.150	0.157
C	1.35	1.75	0.054	0.068
D	0.35	0.49	0.014	0.019
F	0.40	1.25	0.016	0.049
G	1.27 BSC		0.050 BSC	
J	0.19	0.25	0.008	0.009
K	0.10	0.25	0.004	0.009
M	0°	7°	0°	7°
P	5.80	6.20	0.229	0.244
R	0.25	0.50	0.010	0.019

# MC74HC4316A

## PACKAGE DIMENSIONS

TSSOP-16  
DT SUFFIX  
CASE 948F-01  
ISSUE O

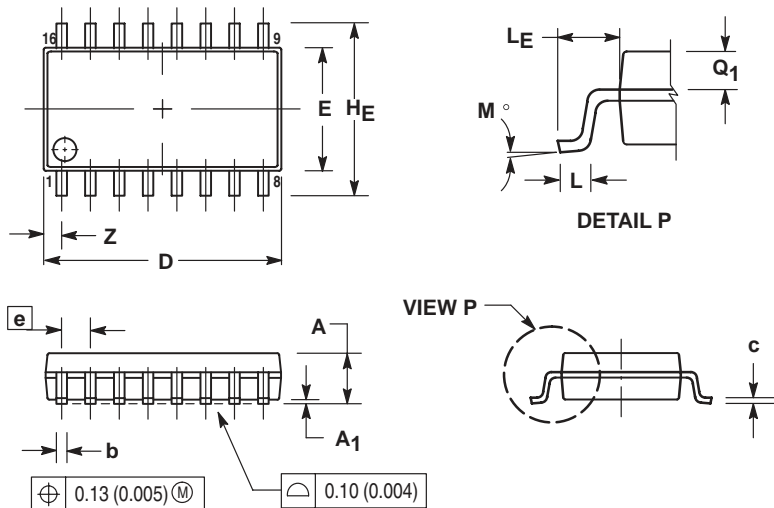


NOTES:

1. DIMENSIONING AND TOLERANCING PER ANSI Y14.5M, 1982.
2. CONTROLLING DIMENSION: MILLIMETER.
3. DIMENSION A DOES NOT INCLUDE MOLD FLASH, PROTRUSIONS OR GATE BURRS. MOLD FLASH OR GATE BURRS SHALL NOT EXCEED 0.15 (0.006) PER SIDE.
4. DIMENSION B DOES NOT INCLUDE INTERLEAD FLASH OR PROTRUSION. INTERLEAD FLASH OR PROTRUSION SHALL NOT EXCEED 0.25 (0.010) PER SIDE.
5. DIMENSION K DOES NOT INCLUDE DAMBAR PROTRUSION. ALLOWABLE DAMBAR PROTRUSION SHALL BE 0.08 (0.003) TOTAL IN EXCESS OF THE K DIMENSION AT MAXIMUM MATERIAL CONDITION.
6. TERMINAL NUMBERS ARE SHOWN FOR REFERENCE ONLY.
7. DIMENSION A AND B ARE TO BE DETERMINED AT DATUM PLANE -W-.

DIM	MILLIMETERS		INCHES	
	MIN	MAX	MIN	MAX
A	4.90	5.10	0.193	0.200
B	4.30	4.50	0.169	0.177
C	—	1.20	—	0.047
D	0.05	0.15	0.002	0.006
F	0.50	0.75	0.020	0.030
G	0.65 BSC		0.026 BSC	
H	0.18	0.28	0.007	0.011
J	0.09	0.20	0.004	0.008
J1	0.09	0.16	0.004	0.006
K	0.19	0.30	0.007	0.012
K1	0.19	0.25	0.007	0.010
L	6.40 BSC		0.252 BSC	
M	0°	8°	0°	8°

SOEIAJ-16  
F SUFFIX  
PLASTIC EIAJ SOIC PACKAGE  
CASE 966-01  
ISSUE O



NOTES:


1. DIMENSIONING AND TOLERANCING PER ANSI Y14.5M, 1982.
2. CONTROLLING DIMENSION: MILLIMETER.
3. DIMENSIONS D AND E DO NOT INCLUDE MOLD FLASH OR PROTRUSIONS AND ARE MEASURED AT THE PARTING LINE. MOLD FLASH OR PROTRUSIONS SHALL NOT EXCEED 0.15 (0.006) PER SIDE.
4. TERMINAL NUMBERS ARE SHOWN FOR REFERENCE ONLY.
5. THE LEAD WIDTH DIMENSION (b) DOES NOT INCLUDE DAMBAR PROTRUSION. ALLOWABLE DAMBAR PROTRUSION SHALL BE 0.08 (0.003) TOTAL IN EXCESS OF THE LEAD WIDTH DIMENSION AT MAXIMUM MATERIAL CONDITION. DAMBAR CANNOT BE LOCATED ON THE LOWER RADIUS OR THE FOOT. MINIMUM SPACE BETWEEN PROTRUSIONS AND ADJACENT LEAD TO BE 0.46 (0.018).

DIM	MILLIMETERS		INCHES	
	MIN	MAX	MIN	MAX
A	—	2.05	—	0.081
A1	0.05	0.20	0.002	0.008
b	0.35	0.50	0.014	0.020
c	0.18	0.27	0.007	0.011
D	9.90	10.50	0.390	0.413
E	5.10	5.45	0.201	0.215
e	1.27 BSC		0.050 BSC	
HE	7.40	8.20	0.291	0.323
L	0.50	0.85	0.020	0.033
LE	1.10	1.50	0.043	0.059
M	0°	10°	0°	10°
Q1	0.70	0.90	0.028	0.035
Z	—	0.78	—	0.031

## Notes

## Notes

## Notes

**ON Semiconductor** and  are trademarks of Semiconductor Components Industries, LLC (SCILLC). SCILLC reserves the right to make changes without further notice to any products herein. SCILLC makes no warranty, representation or guarantee regarding the suitability of its products for any particular purpose, nor does SCILLC assume any liability arising out of the application or use of any product or circuit, and specifically disclaims any and all liability, including without limitation special, consequential or incidental damages. "Typical" parameters which may be provided in SCILLC data sheets and/or specifications can and do vary in different applications and actual performance may vary over time. All operating parameters, including "Typicals" must be validated for each customer application by customer's technical experts. SCILLC does not convey any license under its patent rights nor the rights of others. SCILLC products are not designed, intended, or authorized for use as components in systems intended for surgical implant into the body, or other applications intended to support or sustain life, or for any other application in which the failure of the SCILLC product could create a situation where personal injury or death may occur. Should Buyer purchase or use SCILLC products for any such unintended or unauthorized application, Buyer shall indemnify and hold SCILLC and its officers, employees, subsidiaries, affiliates, and distributors harmless against all claims, costs, damages, and expenses, and reasonable attorney fees arising out of, directly or indirectly, any claim of personal injury or death associated with such unintended or unauthorized use, even if such claim alleges that SCILLC was negligent regarding the design or manufacture of the part. SCILLC is an Equal Opportunity/Affirmative Action Employer.

## PUBLICATION ORDERING INFORMATION

### **NORTH AMERICA Literature Fulfillment:**

Literature Distribution Center for ON Semiconductor  
P.O. Box 5163, Denver, Colorado 80217 USA  
**Phone:** 303-675-2175 or 800-344-3860 Toll Free USA/Canada  
**Fax:** 303-675-2176 or 800-344-3867 Toll Free USA/Canada  
**Email:** ONlit@hibbertco.com  
Fax Response Line: 303-675-2167 or 800-344-3810 Toll Free USA/Canada

**N. American Technical Support:** 800-282-9855 Toll Free USA/Canada

**EUROPE:** LDC for ON Semiconductor – European Support

**German Phone:** (+1) 303-308-7140 (M-F 1:00pm to 5:00pm Munich Time)  
**Email:** ONlit-german@hibbertco.com  
**French Phone:** (+1) 303-308-7141 (M-F 1:00pm to 5:00pm Toulouse Time)  
**Email:** ONlit-french@hibbertco.com  
**English Phone:** (+1) 303-308-7142 (M-F 12:00pm to 5:00pm UK Time)  
**Email:** ONlit@hibbertco.com

**EUROPEAN TOLL-FREE ACCESS\*: 00-800-4422-3781**

\*Available from Germany, France, Italy, England, Ireland

### **CENTRAL/SOUTH AMERICA:**

**Spanish Phone:** 303-308-7143 (Mon-Fri 8:00am to 5:00pm MST)  
**Email:** ONlit-spanish@hibbertco.com

**ASIA/PACIFIC:** LDC for ON Semiconductor – Asia Support

**Phone:** 303-675-2121 (Tue-Fri 9:00am to 1:00pm, Hong Kong Time)  
Toll Free from Hong Kong & Singapore:  
**001-800-4422-3781**  
**Email:** ONlit-asia@hibbertco.com

**JAPAN:** ON Semiconductor, Japan Customer Focus Center  
4-32-1 Nishi-Gotanda, Shinagawa-ku, Tokyo, Japan 141-8549  
**Phone:** 81-3-5740-2745

**Email:** r14525@onsemi.com

**ON Semiconductor Website:** <http://onsemi.com>

For additional information, please contact your local Sales Representative.