

# Customer Information Sheet

DRAWING No.: R40-301XX02

SHEET 2 OF 2

IF IN DOUBT - ASK

©

NOT TO SCALE

THIRD ANGLE PROJECTION

ALL DIMENSIONS IN mm

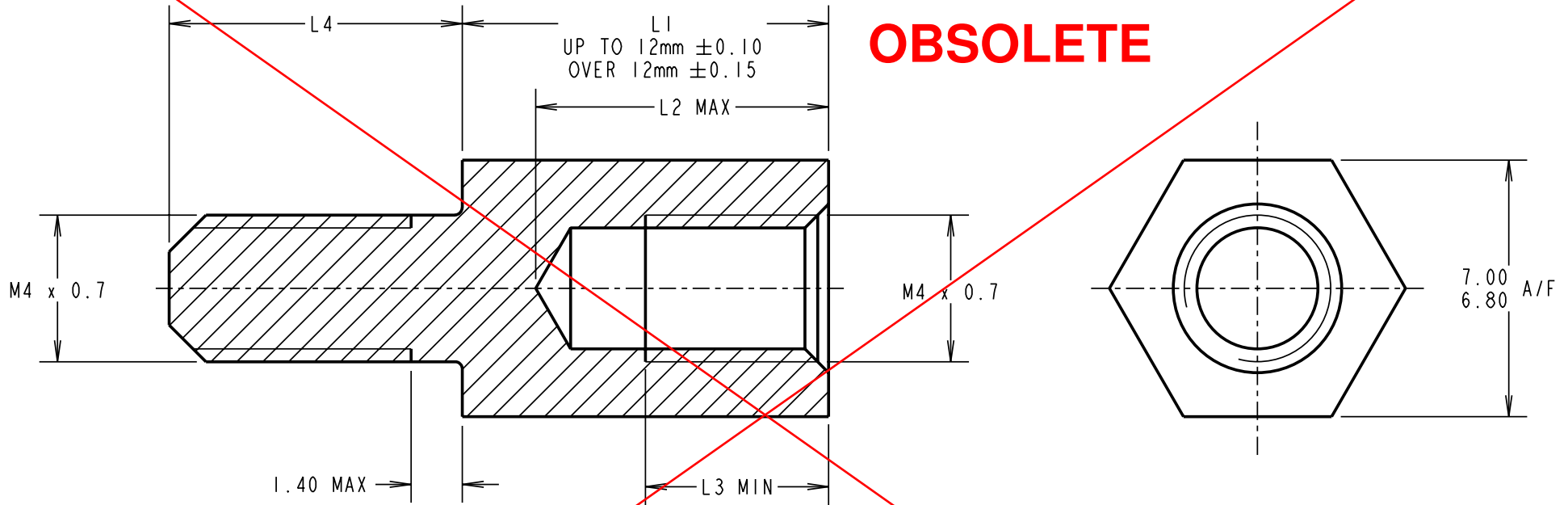

**OBSOLETE**

PART No.	L1	L2	L3	L4
R40-3010802	8.00	7.0	5.00	8.00
R40-3011002	10.00	8.0	5.00	8.00
R40-3011502	15.00	12.0	8.00	8.00
R40-3012002	20.00	12.0	8.00	8.00
R40-3012502	25.00	15.0	10.00	10.00
R40-3013002	30.00	15.0	10.00	10.00

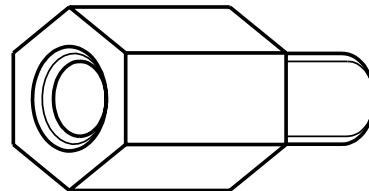

ORDER CODE:  
**R40-301XX02**  
LENGTH L1 IN mm \_\_\_\_\_

SF	4	09.10.08	10174
NAME	ISS.	DATE	C/NOTE
APPROVED:		SF	
CHECKED:		MGP	
DRAWN:		WJ BOURNE	
CUSTOMER REF.:			
ASSEMBLY DRG:			

**HARWIN**

HARWIN USA  
TEL: 603 893 5376  
FAX: 603 893 5396  
mis@harwin.com

HARWIN Europe (UK)  
TEL: 023 9231 4545  
FAX: 023 9231 4590  
mis@harwin.co.uk

HARWIN Asia  
TEL: +65 6 779 4909  
FAX: +65 6 779 3868  
mis@harwin.com.sg

THIS DRAWING AND ANY INFORMATION OR DESCRIPTIVE MATTER SET OUT HEREON ARE CONFIDENTIAL AND COPYRIGHT PROPERTY OF THE HARWIN GROUP AND MUST NOT BE DISCLOSED, LOANED, COPIED OR USED FOR MANUFACTURING, TENDERING OR FOR ANY OTHER PURPOSE WITHOUT THEIR WRITTEN PERMISSION.

**TOLERANCES**

X. = ±1mm  
X.X = ±0.25mm  
X.XX = ±0.10mm  
X.XXX = ±0.01mm  
ANGLES = ±5°  
UNLESS STATED

**MATERIAL:**

BRASS CW614N M TO BS EN 12164 (CuZn39Pb3)

FINISH: NICKEL

S/AREA: mm<sup>2</sup>

**TITLE:**

M4 HEXAGONAL MALE/FEMALE SPACER

DRAWING NUMBER:

**R40-301XX02**

SHT  
2 OF 2