

PRODUCT NO.  
73725

PRODUCT NUMBER CODE

73725-X X X X LF

HOUSING COLOR OPTION

- 0-WHITE
- 1-BLACK

SENSOR CONTACT OPTION

- 0-WITH SENSOR CONTACT
- 1-WITHOUT SENSOR CONTACT

SHIELD PLATING OPTION

- 1- 1.25µm MINIMUM NICKEL UNDERPLATE & 2.5µm MINIMUM BRIGHT TIN OVER ALL AREA. (HOLD DOWN STYLE "A")
- 2- 1.25µm MINIMUM NICKEL UNDERPLATED OVER ALL; 2.5 µm MINIMUM MATTE TIN PLATED ON HOLD DOWN AREA ONLY.(HOLD DOWN STYLE "B")
- 3- 1.25µm MINIMUM NICKEL UNDERPLATED OVER ALL; 2.5 µm MINIMUM MATTE TIN PLATED ON HOLD DOWN AREA ONLY.(HOLD DOWN STYLE "A")
- 4- 1.25µm MINIMUM NICKEL UNDERPLATED & 2.5µm MINIMUM BRIGHT TIN OVER ALL AREA. (HOLD DOWN STYLE "B")
- 5- 1.25µm MINIMUM NICKEL UNDERPLATED OVER ALL; 2.5µm MINIMUM MATTE TIN PLATED ON HOLD DOWN AREA ONLY (HOLD DOWN STYLE "C")
- 6- 1.25µm MINIMUM NICKEL ONLY. (HOLD DOWN STYLE "A")
- 7- 1.25µm MINIMUM NICKEL UNDERPLATED & 2.5 µm MINIMUM MATTE TIN PLATED OVER ALL. (HOLD DOWN STYLE "A")
- 8- 1.25µm MINIMUM NICKEL UNDERPLATED & 2.5 µm MINIMUM MATTE TIN PLATED ALL AREA. (HOLD DOWN STYLE "B")
- 9- 1.25µm MINIMUM NICKEL UNDERPLATED OVER ALL; 2.5 µm MINIMUM MATTE TIN PLATED ON HOLD DOWN AREA ONLY (HOLD DOWN STYLE "D")
- S- 1.25µm MINIMUM NICKEL ONLY.(HOLD DOWN STYLE "A"). HIGH PERFORMANCE MATERIAL FOR 12,000 DURABILITY CYCLES
- A- 1.25µm MINIMUM NICKEL PLATED OVER ALL 2.5 µm MINIMUM MATTE TIN PLATED ON HOLD DOWN AREA ONLY (HOLD DOWN STYLE "F")
- B- 1.25µm MINIMUM NICKEL PLATED OVER ALL 2.5 µm MINIMUM MATTE TIN PLATED ON HOLD DOWN AREA ONLY (HOLD DOWN STYLE "F")

TERMINAL OPTION

50u" NI UNDERPLATE; 30u" GXT CONTACT AREA,100u" TIN TAIL AREA;

- 0- DIM "A": 2.29 (TERMINAL TAIL LENGTH);
- 1- DIM "A": 3.71 (TERMINAL TAIL LENGTH);

LEAD FREE OPTION  
SEE NOTE 9

PACKAGING OPTION  
B - TUBE  
R - TAPE&REEL

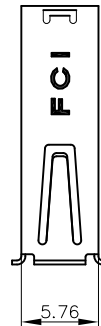

SENSOR CONTACT

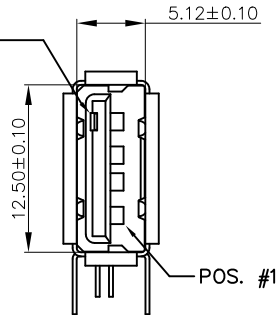

WITH SENSOR CONTACT

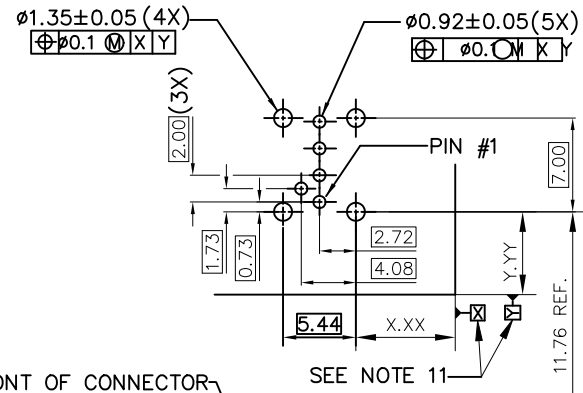

FRONT OF CONNECTOR

PC BOARD MOUNTING DIMENSIONS FOR 5 PIN

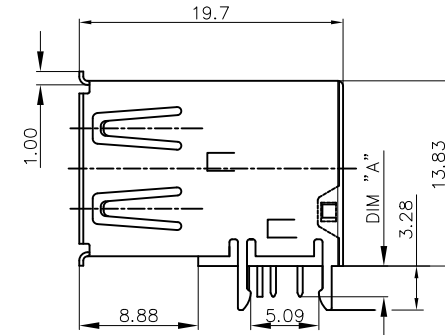

FOR 73725-X0X0B  
HOLD DOWN STYLE "A"

NOTES:

1. MATERIAL:  
CONTACTS: COPPER ALLOY  
SHIELD: COPPER ALLOY  
HOUSING: UL 94V-0 THERMOPLASTIC, COLOR: SEE PRODUCT CODE
2. PLATING:  
CONTACTS: GOLD FLASH OVER PALLADIUM NICKEL (0.76µm MINIMUM) IN CONTACT AREA; 2.5 µm TIN MINIMUM IN SOLDER TAIL AREA.  
SHIELD: SEE PRODUCT NUMBER CODE.  
(THE PLATING MEASURE POINT ON THE SHIELD HOLD DOWN AREA ONLY).
3. DATUMS & BASIC DIMENSIONS TO BE DETERMINED BY CUSTOMER
4. RECOMMENDED PCB BOARD THICKNESS IS 1.00 ~ 1.60mm EXCEPT 73725-1191BLF; 73725-1191BLF CAN BE USED FOR THE PCB BOARD THICKNESS 2.30 ~ 2.65mm.
5. MAXIMUM PANEL THICKNESS TO BE 2.67mm IF MOUNTED BEHIND PANEL
6. METAL SHELL SLIVER 0.20 MAX.
7. NI PLATING DOES NOT COMPLY WITH THE USB STANDARDS (TO BE CONTINUED)

mat'l. code		surface <sup>123</sup> /tolerance		projection		product family	
		ISO 1302 ✓ / ISO 406 ISO 1101		mm		HPL 511 USB 2.0	
ltr		ecn no		dr		date	
AJ		ELX-N-27708		LZ		2017/08/15	
		angles		linear		tolerances unless otherwise specified	
						title	
						USB UP-RIGHT RECEIPT	
AD		ELX-N-012006		A.ZH		06/25/2012	
AE		ELX-N-13463		A.ZH		11/14/2012	
AF		ELX-N-14592		J.HAN		06/10/2013	
AG		ELX-N-21594		LQ		08/04/2015	
AH		ELX-N-21919		LQ		08/04/2015	
sheet		revision		app'd		JENN TSAO 5/20/97	
index		sheet					



Amphenol FCI B 2016 AFCI C D

PRODUCT NO.  
73725

(CONTINUED)

8. P/N'S WITH SUFFIX "LF" ARE LEAD FREE P/N'S

FOR LEAD FREE P/N, THE PRODUCT MEET EUROPEAN UNION DIRECTIVES AND OTHER COUNTRY REGULATION AS DESCRIBED IN GS-22-008

FOR THE PRODUCTS WITH THE METAL SHELL PLATING NICKEL AND MATTE SN CAN WITHSTAND EXPOSURE TO 260°C PEAK TEMPERATURE FOR 40 SECONDS IN A CONVECTION, INFRA-RED OR VAPOR PHASE REFLOW PROCESS; FOR THE PRODUCTS WITH METAL SHELL PLATING BRIGHT SN OR SEMI-BRIGHT SN CAN'T WITHSTAND REFLOW AND JUST CAN WITHSTAND EXPOSURE TO 260°C PEAK TEMPERATURE FOR 10 SECONDS IN WAVE SOLDERING PROCESS.

FOR ALL LEAD FREE P/N'S, WITH SUFFIX LF.

12. THE PRODUCT CAN BE USED FOR PIP PROCESS

13. DATUM OF CUSTOMER'S PCB LAYOUT.

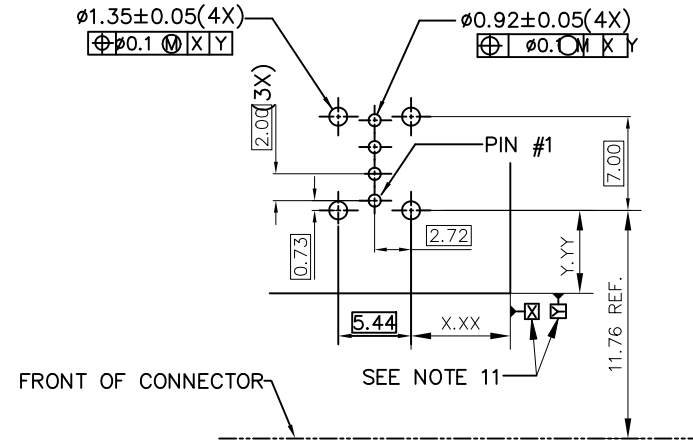
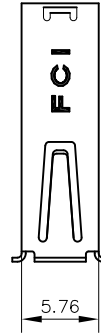

PC BOARD MOUNTING DIMENSIONS FOR 4 PIN

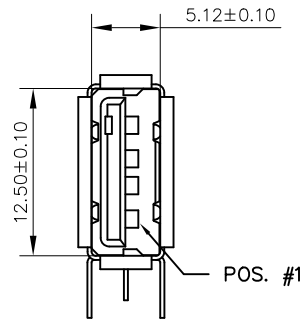
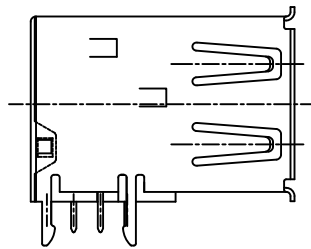

WITHOUT SENSOR CONTACT

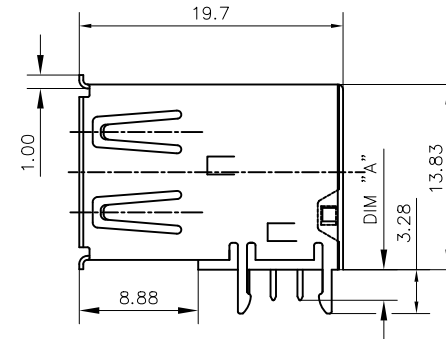

FOR 73725-X1X0B  
HOLD DOWN STYLE "A"

mat'l. code		surface <sub>123</sub> / tolerance		projection		product family	
		ISO 1302 ✓ / ISO 406 ISO 1101				HPL 511 USB 2.0	
ltr		ecn no dr date		tolerances unless otherwise specified		title	
AJ				angles linear		USB UP-RIGHT RECEIPT	
				0°±2'		mm	
						scale 1:1	
		dr PAMP 5/20/97				dwg no sheet 2 of 4 size	
		eng R Y LIU 5/20/97		Amphenol FCI		73725 A3	
		chr R Y LIU 5/20/97				type Product Customer Drawing	
		app JENN TSAO 5/20/97					
sheet		revision					
index		sheet					

PRODUCT NO.  
73725

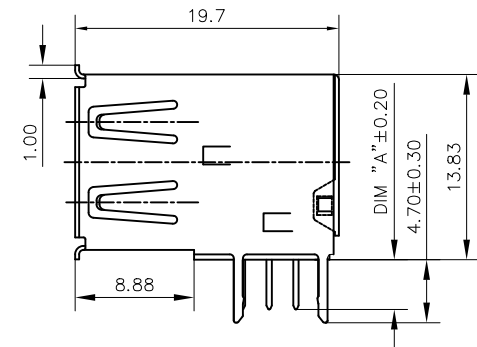
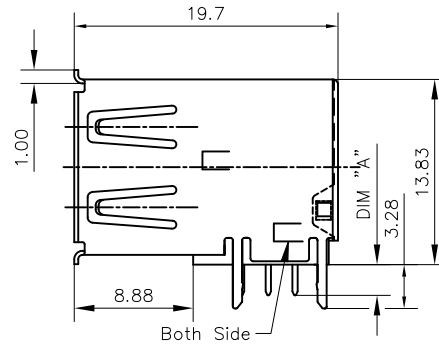
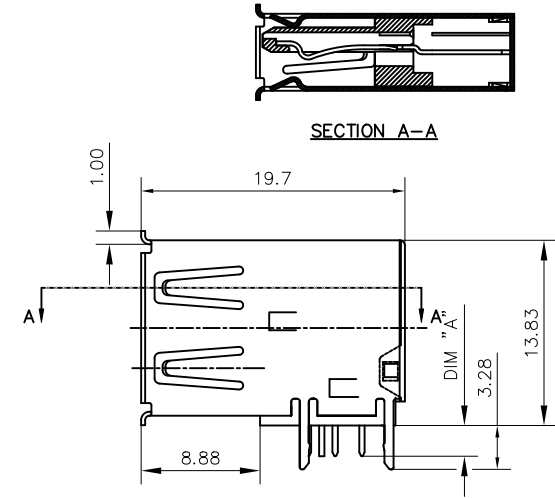
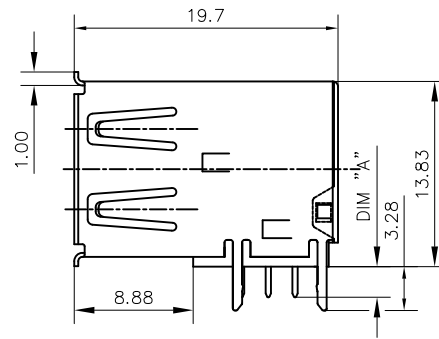
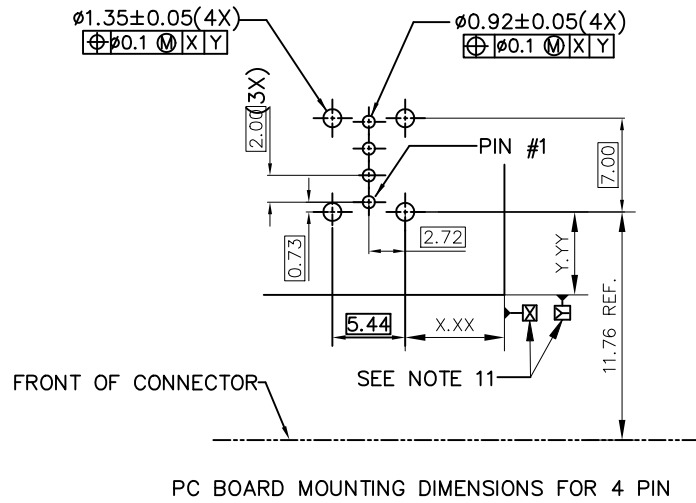

Amphenol FCI  
© 2016 AFCI

mat'l. code		surface <sup>123</sup> tolerance		projection		product family	
		ISO 1302 ✓ ISO 406 ISO 1101				HPL 511 USB 2.0	
ltr		ecn no dr date		tolerances unless otherwise specified		title	
AJ				angles linear .0±.30 .00±.20 0°±2' .000±.10		USB UP-RIGHT RECEIPT	
		dr PAMP 5/20/97				dwg no sheet 3 of 4 size	
		eng R Y LIU 5/20/97		scale 1:1		73725 A3	
		chr R Y LIU 5/20/97				type Product Customer Drawing	
		app JENN TSAO 5/20/97					
sheet index		revision sheet					

PRODUCT NO.  
73725

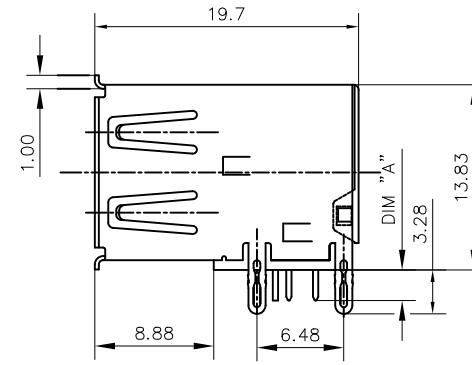
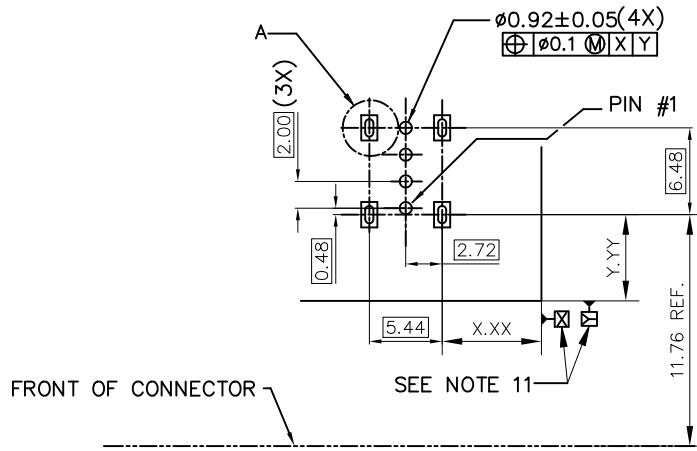

WITHOUT SENSOR CONTACT  
FOR 73725-X150B  
HOLD DOWN STYLE "C"

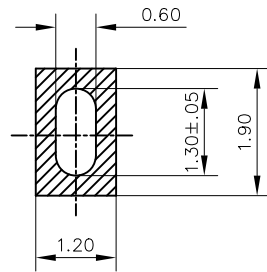

mat'l. code		surface <sub>123</sub> tolerance		projection		product family	
		ISO 1302 ✓ ISO 406 ISO 1101				HPL 511 USB 2.0	
ltr		ecn no dr date		tolerances unless otherwise specified		title	
AJ				angles linear $.0 \pm .30$ $.00 \pm .20$ $.000 \pm .10$			
				scale 1:1		title USB UP-RIGHT RECEIPT	
		dr PAMP 5/20/97		Amphenol FCI		dwg no sheet 4 of 4 size 73725 A3	
		eng R Y LIU 5/20/97				type Product Customer Drawing	
		chr R Y LIU 5/20/97					
		app JENN TSAO 5/20/97					
sheet index		revision sheet					