

HOA2004

Transmissive Optoschmitt Sensor

FEATURES

- Direct TTL interface
- Buffer logic
- Side mount package
- 0.125 in.(3.18 mm) slot width

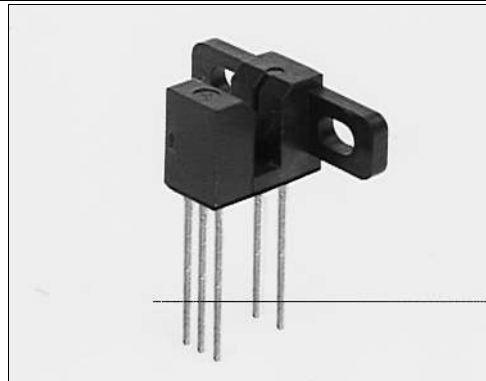

INFRA-67.TIF

DESCRIPTION

The HOA2004 consists of an infrared emitting diode facing an Optoschmitt detector encased in a black thermoplastic housing. The photodetector consists of a photodiode, amplifier, voltage regulator, Schmitt trigger and an NPN output transistor with 10 kΩ (nominal) pull-up resistor. The buffer logic provides a high output when the optical path is clear, and a low output when the path is interrupted. The side mounting package is useful in applications in which the interruptive element is parallel to the mounting plane. Both emitter and detector have a 0.020 in.(.508 mm) x 0.040 in.(1.02 mm) vertical aperture. The narrow aperture is ideal for use in applications in which maximum position resolution is desired. The HOA2004 employs plastic molded components. For additional component information see SEP8506 and SDP8600.

Housing material is polyester. Housings are soluble in chlorinated hydrocarbons and ketones. Recommended cleaning agents are methanol and isopropanol.

OUTLINE DIMENSIONS in inches (mm)

Tolerance 3 plc decimals ±0.010(0.25)
2 plc decimals ±0.020(0.51)

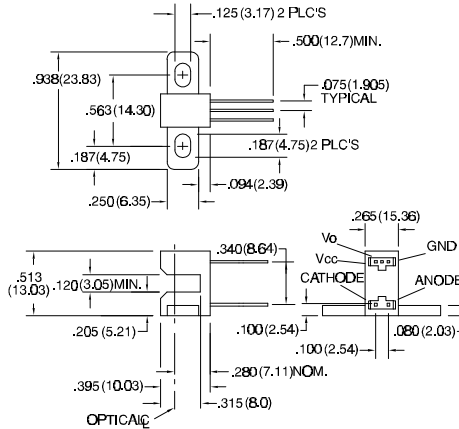

DIM_065.d54

HOA2004

Transmissive Optoschmitt Sensor

ELECTRICAL CHARACTERISTICS (25°C unless otherwise noted)

PARAMETER	SYMBOL	MIN	TYP	MAX	UNITS	TEST CONDITIONS
IR EMITTER						
Forward Voltage	V_F		1.6		V	$I_F=20\text{ mA}$
Reverse Leakage Current	I_R		10		μA	$V_R=3\text{ V}$
DETECTOR						
Operating Supply Voltage	V_{CC}	4.5	12		V	
Low Level Supply Current	$I_{CC(L)}$	4.0	12		mA	$V_{CC}=5\text{ V}$
Low Level Supply Current		5.0	15			$V_{CC}=12\text{ V}$
High Level Supply Current	$I_{CC(H)}$	2.0	10		mA	$V_{CC}=5\text{ V}$
High Level Supply Current		3.0	12			$V_{CC}=12\text{ V}$
Low Level Output Voltage	V_{OL}		0.4		V	$I_{OL}=12.8\text{ mA}, I_F=0\text{ mA}$
High Level Output Voltage	V_{OH}	2.4			V	$I_{OH}=0, I_F=20\text{ mA}$
Hysteresis ⁽²⁾	HYST		10		%	
Propagation Delay, Low-High	t_{PLH}		5		μs	$V_{CC}=5\text{ V}, I_F=20\text{ mA}$
Propagation Delay, High-Low	t_{PHL}		5		μs	$V_{CC}=5\text{ V}, I_F=20\text{ mA}$
Rise Time	t_r		60		ns	$R_L=390\ \Omega, C_L=50\text{ pF}$
Fall Time	t_f		15		ns	$R_L=390\ \Omega, C_L=50\text{ pF}$
COUPLED CHARACTERISTICS						
IRET Trigger Current	I_{FT}		20		mA	$V_{CC}=5\text{ V}$
HOA2004-001						

Notes

1. It is recommended that a bypass capacitor, 0.1 μF typical, be added between V_{CC} and GND near the device in order to stabilize power supply line.
2. Hysteresis is defined as the difference between the operating and release threshold intensities, expressed as a percentage of the operate threshold intensity.

ABSOLUTE MAXIMUM RATINGS

(25°C Free-Air Temperature unless otherwise noted)

Operating Temperature Range	-40°C to 70°C
Storage Temperature Range	-40°C to 85°C
Soldering Temperature (5 sec)	240°C
IR EMITTER	
Power Dissipation	100 mW ⁽¹⁾
Reverse Voltage	3 V
Continuous Forward Current	50 mA
DETECTOR	
Supply Voltage	12 V ⁽²⁾
Output Sink Current	18 mA
Duration of Output	
Short to V_{CC} or Ground	1.0 sec.

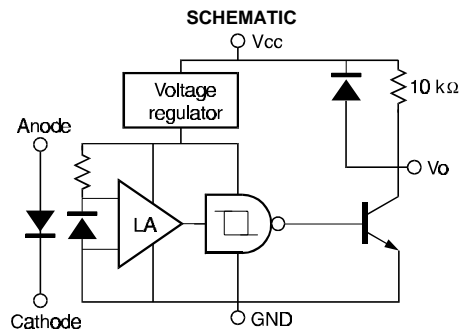

Honeywell reserves the right to make changes in order to improve design and supply the best products possible.

Honeywell

HOA2004

Transmissive Optoschmitt Sensor

SWITCHING WAVEFORM

cir_013.cdr

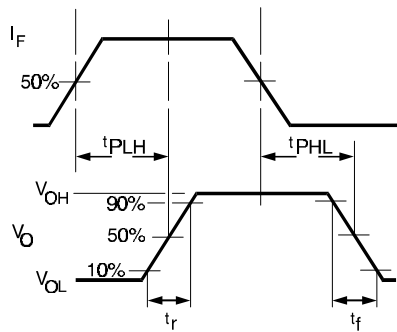

Fig. 2 IRED Trigger Current vs Temperature

gra_098.ds4

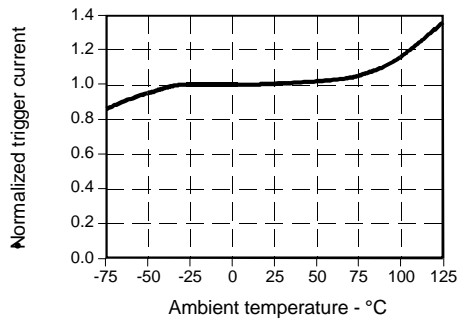
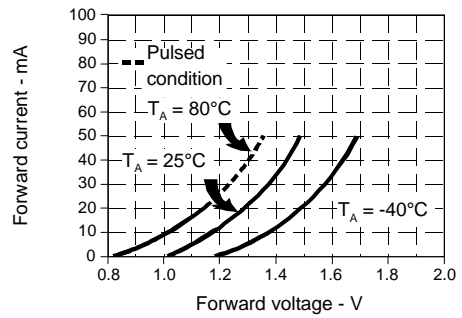

Fig. 1 IRED Forward Bias Characteristics

gra_073.ds4



All Performance Curves Show Typical Values

HOA2004

Transmissive Optoschmitt Sensor

Honeywell reserves the right to make changes in order to improve design and supply the best products possible.

Honeywell

371