

REVISIONS					
P	LTR	DESCRIPTION	DATE	DWN	APVD
H3		REVISED PER ECO-14-002234	17MAY2014	NK	DR
H4		REVISED PER ECO-17-007400	05DEC2017	RS	DR

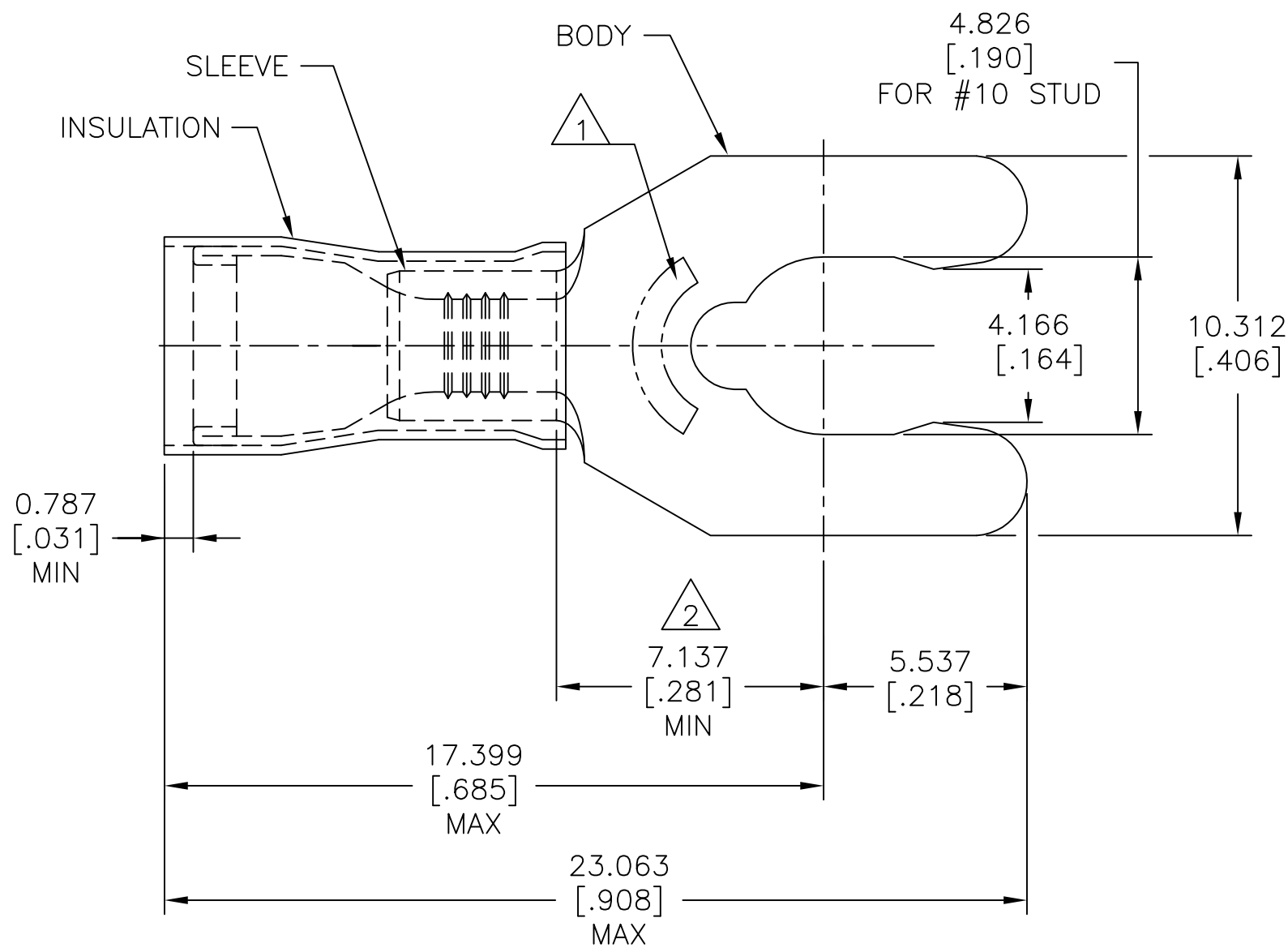

- 1 STAMP 10S AMP 16-14*, APPROX AS SHOWN.
- 2 APPLIES FROM EDGE OF METAL WIRE BARREL TO CENTER OF STUD HOLE.
- 3 BODY MATERIAL THK IS 0.787±0.051[.031±.002]
- 4 BODY - PHOS BRONZE PER ASTM B-103
SLEEVE - COPPER PER ASTM B-152
INSULATION - NYLON
- 5 BODY - TIN PLATE PER ASTM B545
SLEEVE - TIN PLATE PER ASTM B545
INSULATION - COLOR - BLUE

AMP WIRE RANGE	Listed FILE E13288	LR7189 Certified
16-14 AWG SOLID OR STRANDED	16-14 AWG SOLID OR STRANDED	16-14 AWG SOLID OR STRANDED

WIRE INSULATION OD	QTY	PACKAGE TYPE	PART NO
2.921-4.623[.115-.182]	100	LOOSE PIECE, BOX	9-52937-1
2.921-4.623[.115-.182]	4000	-2 ON TAPE	52937-3
2.921-4.623[.115-.182]	1000	LOOSE PIECE	52937-2
2.921-4.318[.115-.170]	4000	-1 ON TAPE	52937-1
2.921-4.318[.115-.170]	1000	LOOSE PIECE	52937

CUSTOMER SERVICE SYSTEMS		MAX RECOMMENDED OPERATING TEMPERATURE: 105°C [221°F]	THIS DRAWING IS A CONTROLLED DOCUMENT.		DWN jr_ruth 19MAR10	TE Connectivity			
FOR ADDITIONAL PRODUCT INFORMATION OR COPIES OF DRAWINGS AND TECHNICAL DOCUMENTS	PRODUCT INFORMATION CENTER 1-800-522-6752	VOLTAGE RATING: 300 V MAX	DIMENSIONS: mm [INCHES]	TOLERANCES UNLESS OTHERWISE SPECIFIED:	CHK T MICHIELUTTI 19MAR10				
FOR APPLICATION TOOLING INFORMATION	TOOLING ASSISTANCE CENTER 1-800-722-1111	CIRCULAR MIL AREA: 1.04-2.62mm² [2,050-5,180] SOLID OR STRANDED		0 PLC ± - 1 PLC ± - 2 PLC ± - 3 PLC ± 0.127[.005] 4 PLC ± - ANGLES ± 5°	APVD T MICHIELUTTI 19MAR10	PRODUCT SPEC UL 486 A-B			
FOR ORDER ENTRY	1-800-526-5142	THIS DRAWING IS A CONTROLLED DOCUMENT FOR AMP INCORPORATED. IT IS SUBJECT TO CHANGE AND THE CONTROLLING ENGINEERING ORGANIZATION SHOULD BE CONTACTED FOR THE LATEST REVISION.	MATERIAL 4	FINISH 5	APPLICATION SPEC 114-2157	SIZE A3	CAGE CODE 00779	DRAWING NO C=52937	RESTRICTED TO -
CUSTOMER DRAWING						SCALE 6:1	SHEET 1 OF 1	REV H4	