



ANATECH ELECTRONICS INC
RF & Microwave Filters & Products

3150 MHz Cavity Band Pass Filter

Part Number: AE3150B11681



Electrical specifications

Center Frequency (CF): 3150 MHz
Relative Bandwidth (1 dB): 505 MHz Min.
Ripple in Passband: 0.5 dB Max.
Insertion loss @ CF: 1 dB Max.
Return loss @ CF: 13 dB Min
Rejection @ CF ± 750 MHz: 40 dB Min
Impedance: 50 Ohms

Mechanical

Mounting Method: Threaded Holes
Connector Type: SMA (F)
Dimensions: 3.50 x 0.75 x 0.50 Inches

Environmental

Operating Temperature: -55 to +85° C
Humidity: Up to 95%
Vibration (5 to 1000 Hz): 10 G Max
Shock (11 Milliseconds): 30 G Max

Outline Drawing:

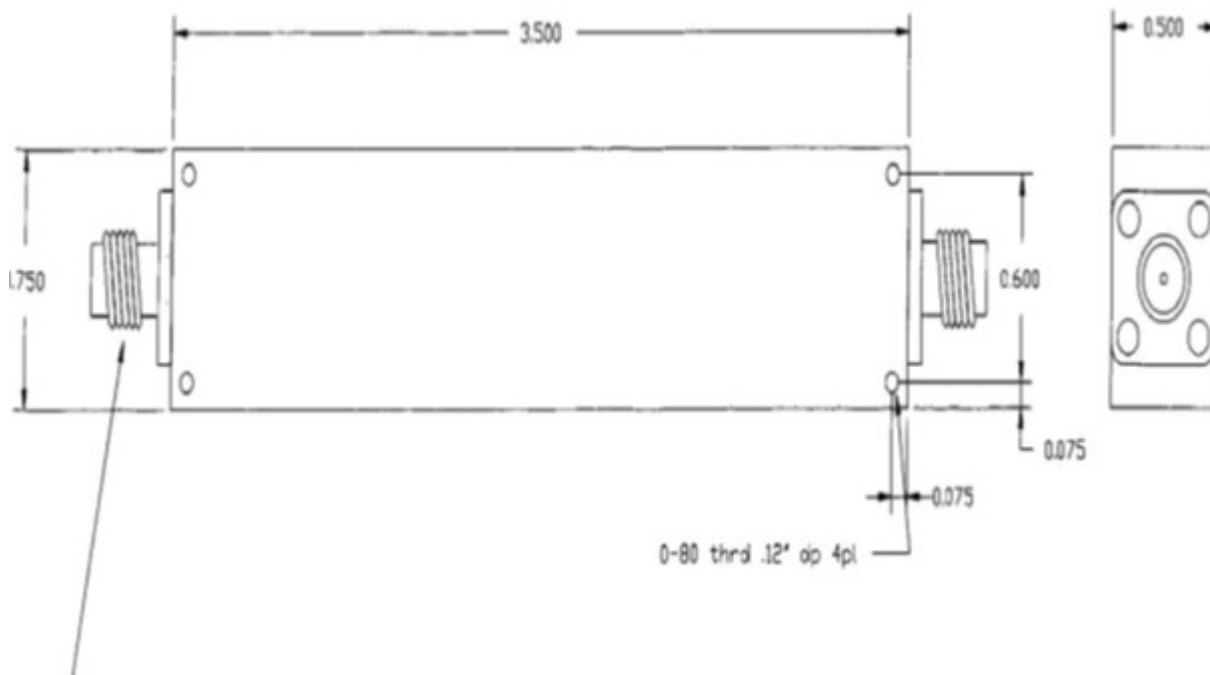

2 decimal places: +/- 0.01 inches [+/- 0.3mm]
 3 decimal places: +/- 0.005 inches [+/- 0.13mm]
 Angles: +/- 1 Deg.

When max dimensions are called out the above tolerances do not apply as long as it is under the max call out.



3150 MHz Cavity Band Pass Filter

Part Number: AE3150B11681



Simulated Plot :

Lumped Filter S Parameters

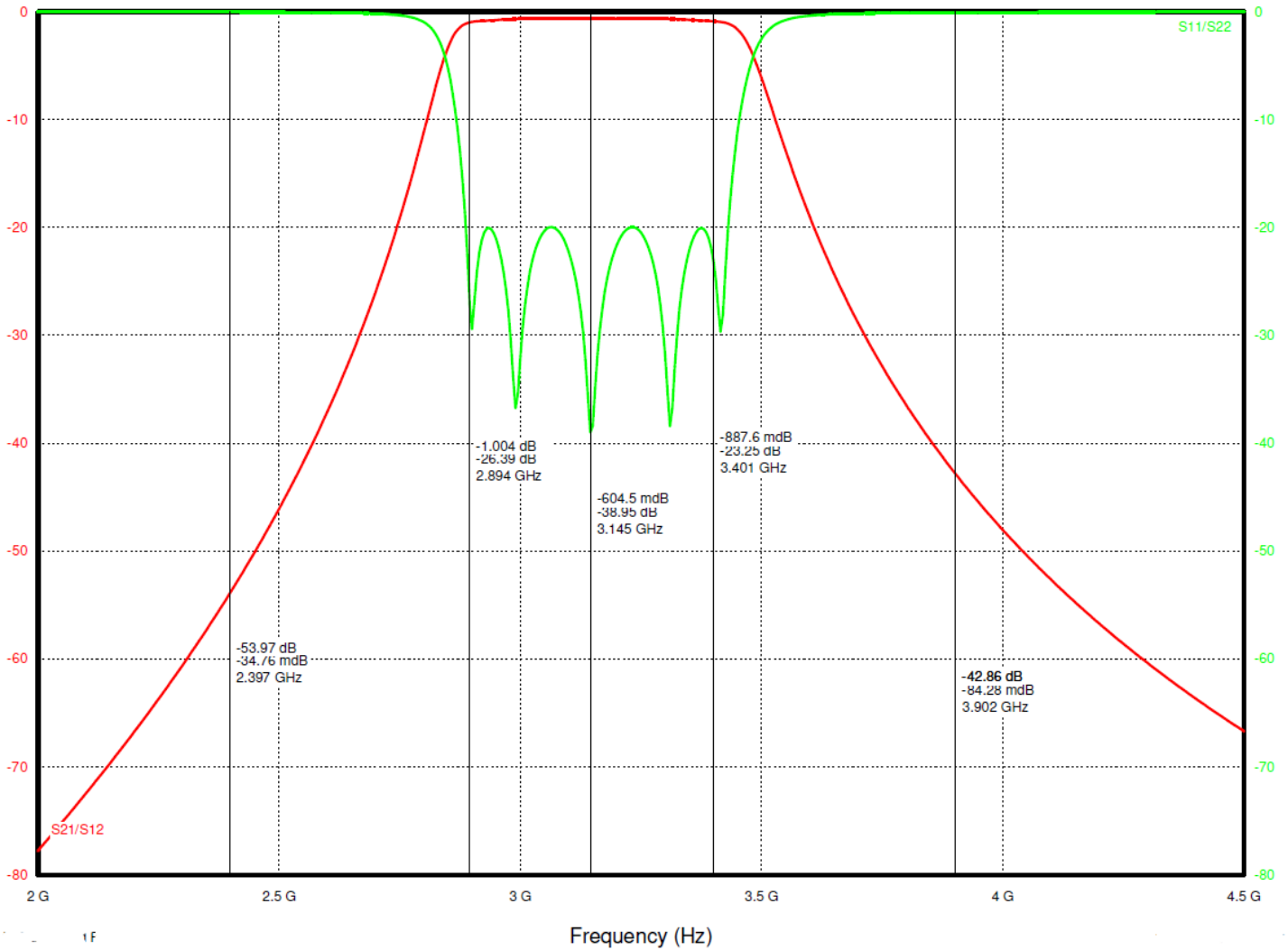

Note: This is a simulated response plot. Actual performance might differ.