

THIS DRAWING IS UNPUBLISHED. RELEASED FOR PUBLICATION  
 © COPYRIGHT - By - ALL RIGHTS RESERVED.

LOC	DIST	REVISIONS			
P	LTR	DESCRIPTION	DATE	DWN	APVD
A1	-				
F		DOVE TAIL ADDED/Schwalbenschwanz eingefuegt	28JUL2006	C.H.	C.G.
G		DRAWING ADAPTED / Zeichnung angepasst	14AUG2007	Abr	C.G.
H		SPOT WELDING CHANGED INTO LINE WELDING	27SEP2012	Sch	Abr

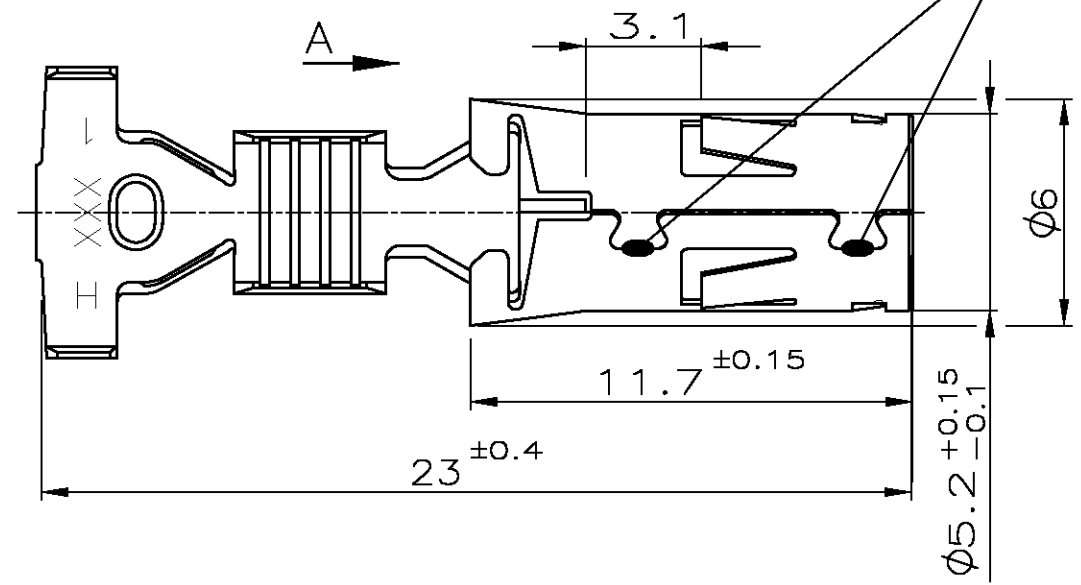
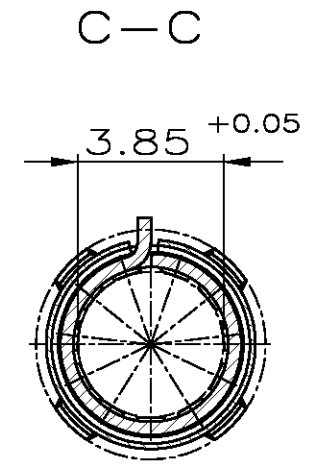
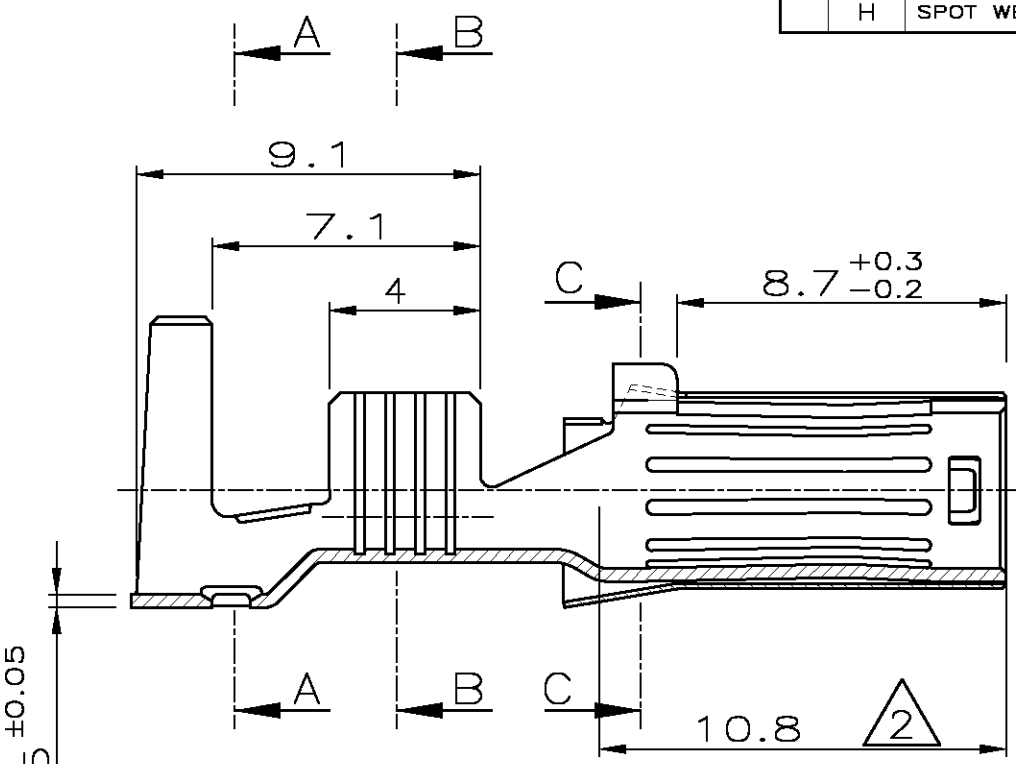
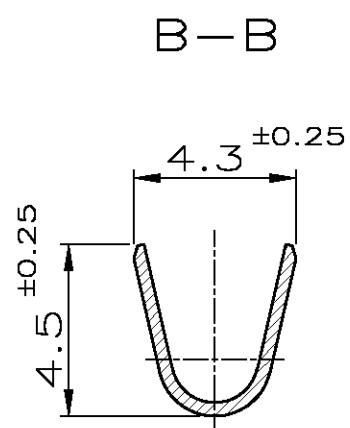
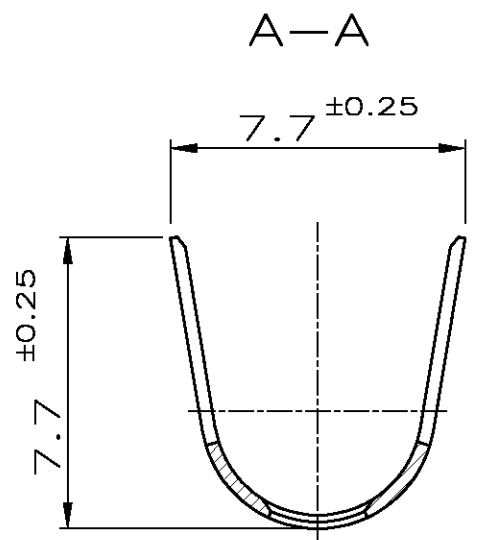

LASER WELDED (LINE)  
Laserschweissung (Linie)

Teilansicht A

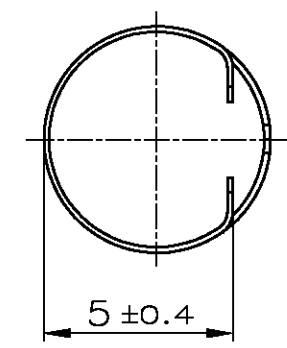

NOTES  
Bemerkungen

- 1 1-3µm Sn  
1-3µm Sn
- 2 3-4µm GALVANIC Ag  
REST GALV. Sn (1-3µm)  
3-4µm galvanisch Ag  
Rest galv. Sn (1-3µm)
- 3 WIRE RANGE  
Drahtgroessenbereich (mm<sup>2</sup>): >2.5-4.0
- 4 INSULATION RANGE FOR SWS Ø6 (mm): 2.7-3.7  
Isolationsbereich fuer EDS Ø6

OPTIONAL

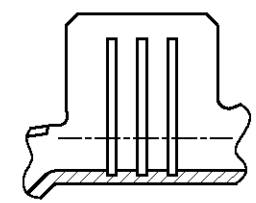

FINISH	PART NO.	REV.
vorversilbert	0-962956-2	H
vorverzinkt	0-962956-1	H

THIS DRAWING IS A CONTROLLED DOCUMENT.		DWN E. Palmie 30JAN1995	TE Connectivity		
DIMENSIONS: mm		CHK H. Lutsch 30JAN1995			
TOLERANCES UNLESS OTHERWISE SPECIFIED: 0 PLC ± ±0.2mm 1 PLC ± ±0.2mm 2 PLC ± ±0.2mm 3 PLC ± ±0.2mm 4 PLC ± ±0.2mm ANGLES ± ±1.5°		APVD -	NAME Ø4mm SOCKET CONTACT, SWS Ø4mm Buchsenkontakt, EDS		
MATERIAL CuNiSi		PRODUCT SPEC 108-18472	SIZE A3	CAGE CODE 00779	DRAWING NO C-962956
FINISH -		APPLICATION SPEC 114-18118	RESTRICTED TO -		SCALE 5:1
		WEIGHT -	SHEET 1 OF 1		REV H
CUSTOMER DRAWING					