

THIS INFORMATION IS CONFIDENTIAL AND PROPRIETARY TO CW INDUSTRIES INCORPORATED AND ITS AFFILIATES. IT MAY NOT BE DISCLOSED TO ANYONE OTHER THAN CW INDUSTRIES PERSONNEL, WITHOUT WRITTEN AUTHORIZATION FROM CW INDUSTRIES INCORPORATED, SOUTHAMPTON, PENNSYLVANIA USA.

DIMENSIONS IN INCHES (MILLIMETERS)  
 DO NOT SCALE DRAWING .....

Dwg. No.  
**GF-423-0018**

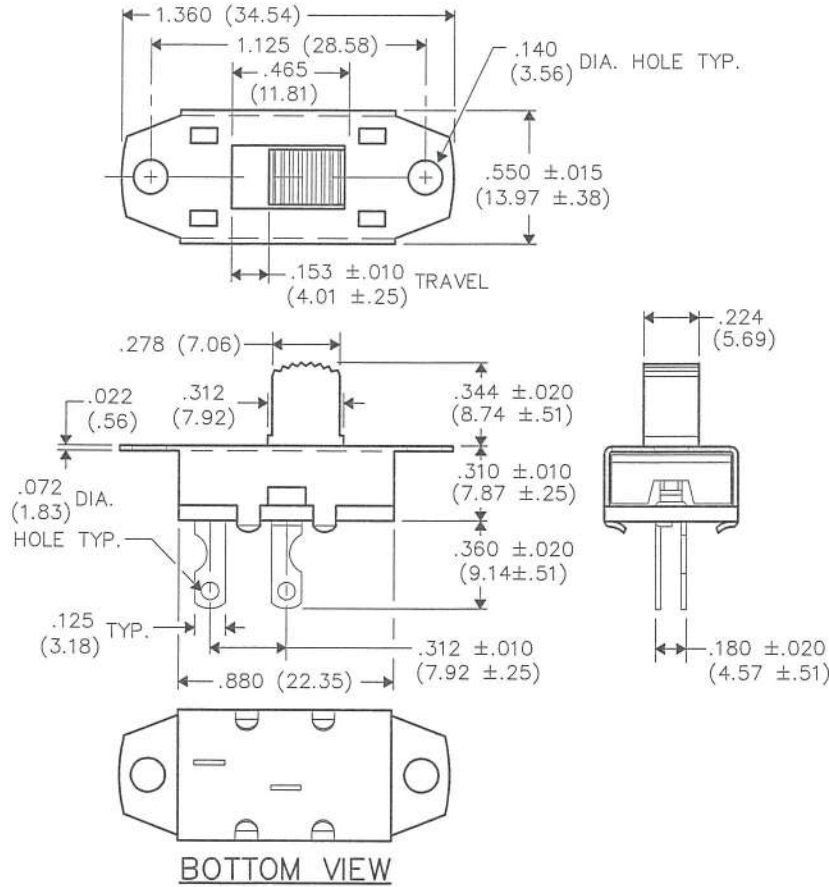

B-FORMAT 2002

**REVISIONS**

RELEASED: 0  
 DGW 7-15-13  
**JUL 19 2013**

1 2 3 4 5 6 7 8 9 10

PDF MADE	<b>CW INDUSTRIES</b> Southampton, Pa. 18966		Title: <b>SWITCH ASSEMBLY S.P. - S.T.</b>	
	TOLERANCES UNLESS OTHERWISE SPECIFIED		METRIC	
	2 Place Decimal ±.010	3 Place Decimal ±.005	1 Place Dec. ±.25mm	2 Place Dec. ±.13mm
	Made for: CW IND.		Division: <b>SWITCH</b>	
Drawn by: DGW 7-15-13		Dwg. No. <b>GF-423-0018</b>		
Checked by: <i>G. Guld 7-19-13</i>		Approval: <i>G. Guld 7-19-13</i>		

**MASTER**