

300U-A SERIES

300 Amp Avg Power Silicon Rectifier Diodes

Major Ratings and Characteristics

		300U-A, 302U-A	Units
$I_F(AV)$		300	A
@ T_C		130	°C
I_{FSM}	@ 50 Hz	5500	A
	@ 60 Hz	5750	
I^2t	@ 50 Hz	151 000	A ² s
	@ 60 Hz	138 000	
$I^2\sqrt{t}$		2,139,000	A \sqrt{s}
V_{RRM} Range		50-1200	V

Description and Features

- Peak reverse voltage up to 1200V
- Popular series for rough service
- For many AC-to-DC circuit applications

CASE STYLE AND DIMENSIONS

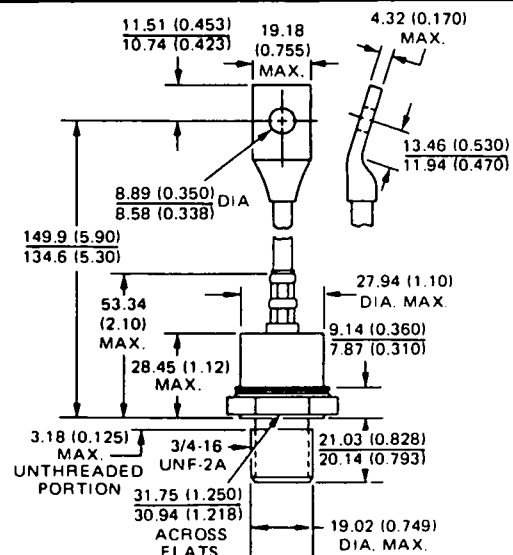
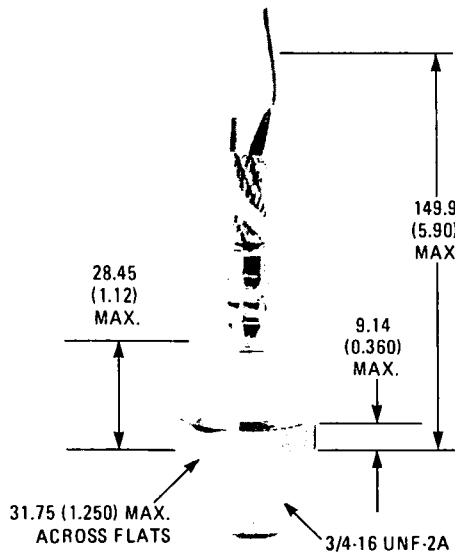

300U-A Series

Conforms to JEDEC Outline DO-206AB (DO-9)
 All Dimensions in Millimeters and (Inches)

300U-A Series

VOLTAGE RATINGS

PART NUMBER ^①		V _{RRM} Max. repetitive peak reverse voltage (V)	V _{RSM} Max. non-repetitive peak reverse voltage (V)	V _R Max. average reverse voltage (V)	I _{RM} Max. peak reverse current at rated V _{RRM} (mA)
DO-205AB (DO-9)					
		T _J = -65°C to 200°C	T _J = -65°C to 200°C	T _J = -65°C to 200°C	T _J = 175°C
300U5A		50	100	50	40
300U10A		100	200	100	40
300U20A		200	300	200	40
300U30A		300	400	300	40
300U40A		400	500	400	40
300U60A		600	720	600	40
300U80A		800	960	800	35
300U100A		1000	1200	1000	30
300U120A		1200	1440	1200	25

① Basic part number indicates cathode-to-case. For anode-to-case, add "R" to part number, i.e., 70UR20, 300UR120A etc.

ELECTRICAL SPECIFICATIONS

		300U-A	Units	Conditions
I _{F(AV)}	Max. average forward current	300	A	1-phase operation, 180° conduction
	@ Max. T _C	130	°C	
I _{FSM}	Max. peak one-cycle non-repetitive surge current	5500	A	Half cycle 50 Hz sine wave or 6 ms rectangular pulse
		5750		Half cycle 60 Hz sine wave or 5 ms rectangular pulse
		6550	A	Half cycle 50 Hz sine wave or 6 ms rectangular pulse
		6850		Half cycle 60 Hz sine wave or 5 ms rectangular pulse
I ² t	Max. I ² t for fusing	151 000	A ² s	With rated V _{RRM} applied following surge, initial T _J = T _J Max.
		138 000		
	Max. I ² t for individual device fusing	214 000		With V _{RRM} = 0 following surge, initial T _J = T _J Max.
		195 000		
I ² √t	Max. I ² √t for individual device fusing	2 139 000	A ² √s	t = 0.1 to 10 ms, V _{RRM} = 0 following surge ^②
V _{FM}	Max. peak forward voltage	-	V	I _{FM} = π × I _{F(AV)} (785 A peak), T _J = 25°C
		1.40	V	I _{FM} = π × I _{F(AV)} (942 A peak), T _J = 25°C
V _{F(TO)}	Max. value of threshold voltage	0.610	V	T _J = 200°C
r _F	Max. value of forward slope resistance	0.751	mΩ	

THERMAL-MECHANICAL SPECIFICATIONS

T _J	Max. operating junction temperature range	-65 to 200	°C	
T _{stg}	Max. storage temperature range	-65 to 200	°C	
R _{thJC}	Max. internal thermal resistance, junction-to-case	0.18	K/W	DC operation
R _{thCS}	Thermal resistance, case-to-sink	0.08	K/W ¹	Mounting surface flat, smooth, and greased.
T	Mounting torque	Min.	31.1 (275)	Nm (lbf-in)
		Max.	36.7 (325)	
wt	Approximate weight	213 (7.5)	g (oz)	
	Case style	DO-205AB (DO-9)		JEDEC

② I²t for time t_x = I²√t_x · √t_x

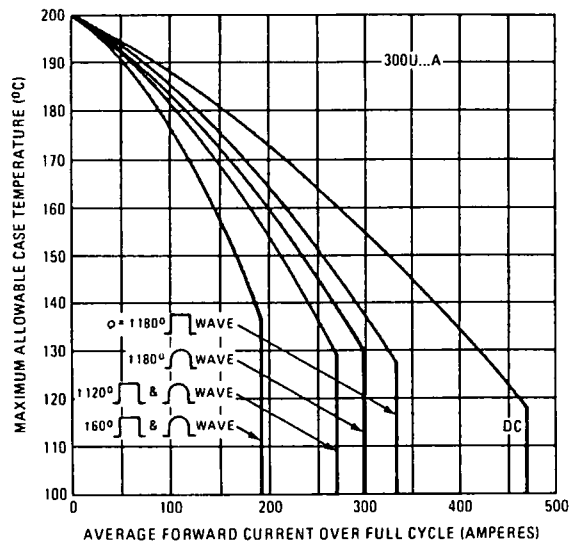

Fig. 2 – Average Forward Current Vs. Maximum Allowable Case Temperature, 300U_A Series

300U-A Series

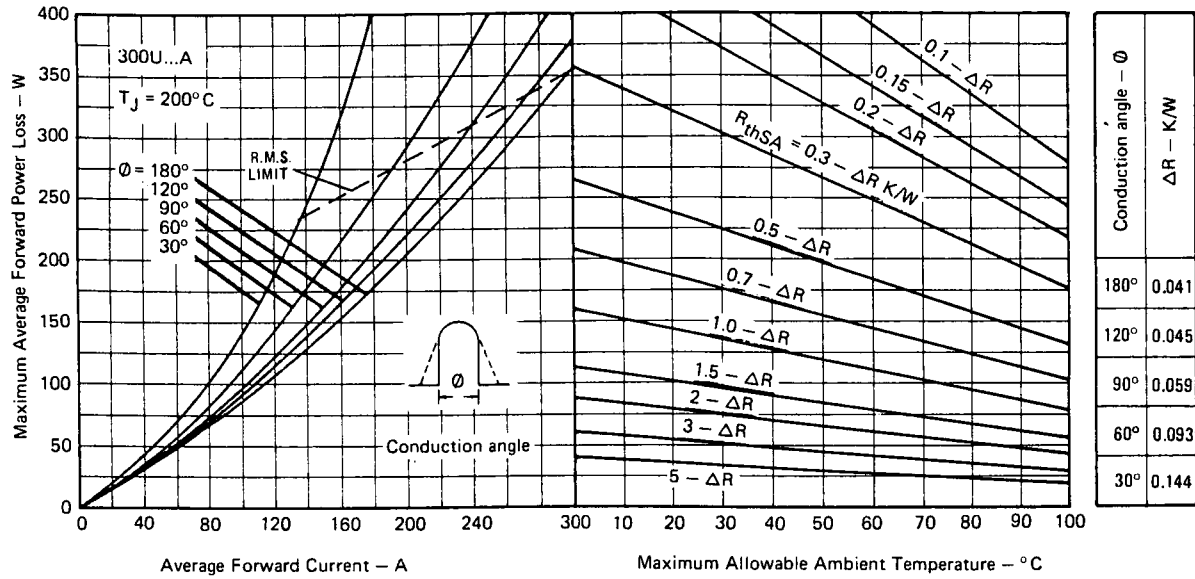

Fig. 5 - Current Rating Nomogram (Sinusoidal Waveforms), 300U-A Series

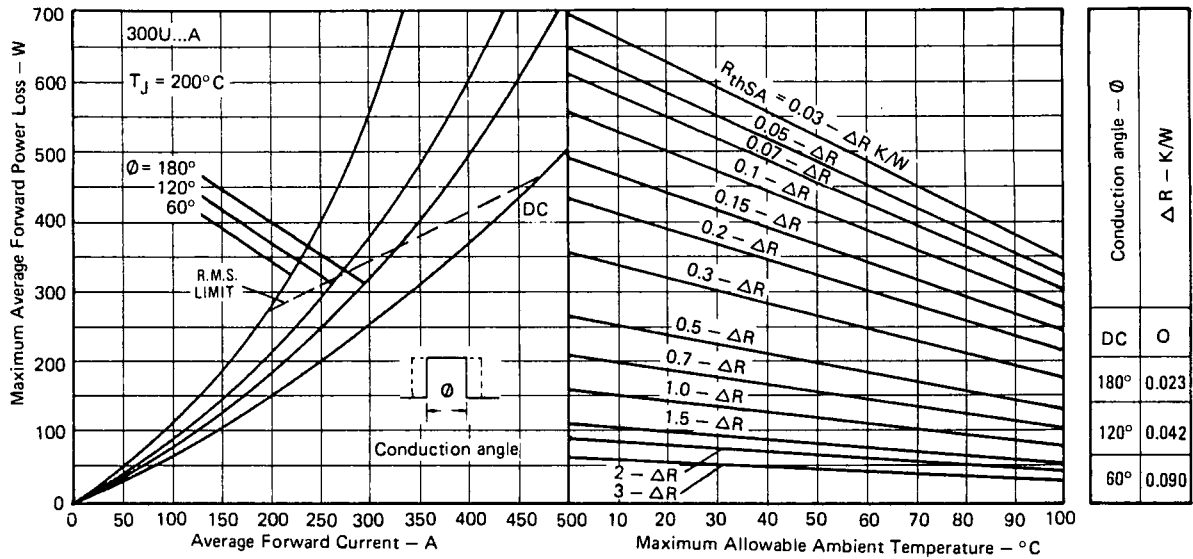

Fig. 6 - Current Rating Nomogram (Rectangular Waveforms) 300U-A Series

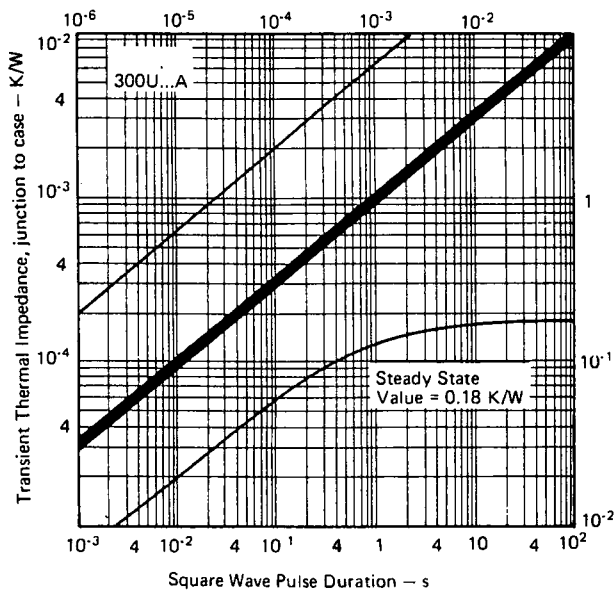

Fig. 7 - Maximum Transient Thermal Impedance, Junction-to-Case Vs. Pulse Duration,

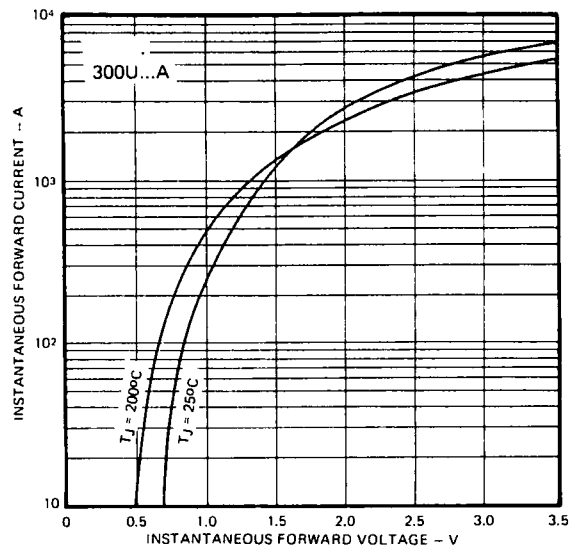

Fig. 8 - Maximum Forward Voltage Vs. Forward Current,

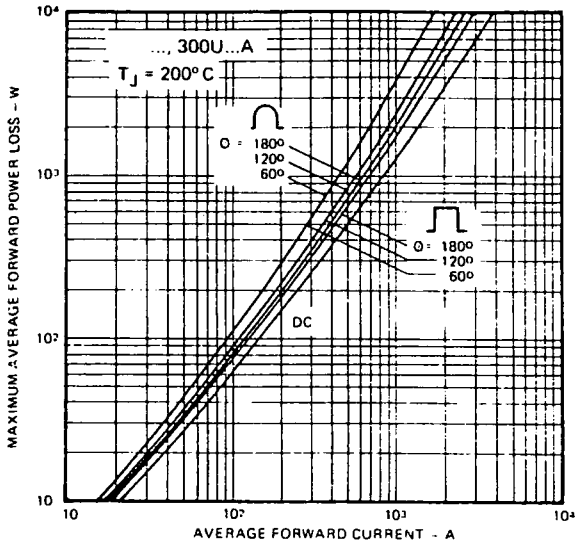

Fig. 9 – Maximum High Level Forward Power Loss Vs. Average Forward Current,

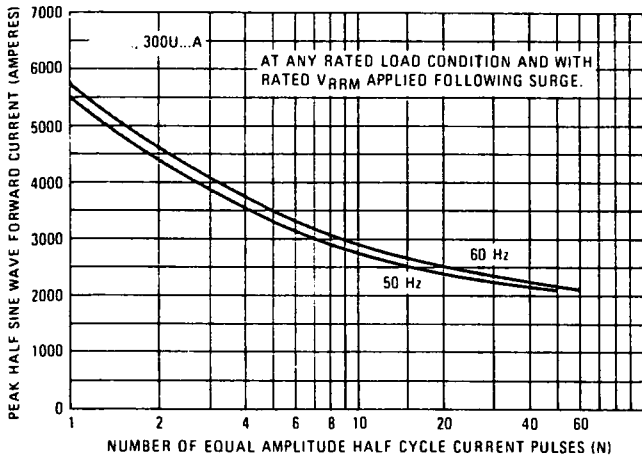

Fig. 10 – Maximum Non-Repetitive Surge Current Vs. Number of Current Pulses,