

RSF70 SERIES

COMPACT EXTERNAL FITTING VIA COMPRESSION SEAL



The RSF70 series is designed for fitting through a tank wall from the outside, where access to the inside for fitting is not possible.

Typical applications include vending machines, commercial dishwashers and auxiliary tanks on vehicles.

These are manufactured in a variety of plastics, with a choice of gasket materials, to suit most commonly used liquids.

The switch action may be reversed by mounting the device with the float able to move upwards away from the body, instead of the more normal downwards direction.

Available with either flying leads or M12 socket for electrical connection. Cable sets with M12 plugs are also available.

Features

- Compression seal fitting
- Flying Lead or M12 plug connection
- Available in Nylon, Polypropylene, PPS or PVDF
- 25VA & 100VA versions
- Many variants are UL recognised components File No. E171218
- WRAS and NSF Approved versions available

SPECIFICATIONS

Technical

	RSF73	RSF74	RSF78	RSF76	RSF77
Material	Nylon	Polypropylene WRAS approved	Polypropylene UL approved	Polyphenylene Sulphide (PPS)	Polyvinylidene Fluoride (PVDF)
Colour	Black	Opaque	White	Grey	Green
Temp. Range	°C °F	-20/+75	-20/+100	-20/+100	-10/+120*
		-4/+167	-4/+212	-4/+212	+14/+248*
Min. Fluid SG	0.85	0.85	0.80	0.85	0.85
Must Close Level (SG=1)	7mm	8mm	8mm	9mm	9mm
Must Open Level (SG=1)	20mm	20mm	20mm	24mm	24mm

* Maximum temperature requires ETFE cable to be specified.

Electrical

		25W (Y code)	100W (H code)
Contact Form		N/O (N/C)	N/O (N/C)
Switching Power Max	VA	25	100
Switching Voltage AC Max	V	240	300
Switching Voltage DC Max	V	120	300
Switching Current Max	A	0.6	1

All ratings are for resistive load only.

STANDARD PARTS

	Material	Max Power	Leadouts	Gasket	Approvals
RSF73H100RN	Nylon	100VA	100cm PVC 16/0.2	Nitrile	WRAS
RSF73Y100RN	Nylon	25VA	100cm PVC 16/0.2	Nitrile	WRAS
RSF73Y100RM	Nylon	25VA	100cm PVC 16/0.2	Silicone	WRAS
RSF74H100RN	Polypropylene	100VA	100cm PVC 16/0.2	Nitrile	WRAS & NSF
RSF74Y100RN	Polypropylene	25VA	100cm PVC 16/0.2	Nitrile	WRAS & NSF
RSF74Y100RM	Polypropylene	25VA	100cm PVC 16/0.2	Silicone	WRAS & NSF
RSF76H050TV	PPS	100VA	50cm ETFE 19/0.2	Viton	WRAS, UL & NSF
RSF76H100RN	PPS	100VA	100cm PVC 16/0.2	Nitrile	WRAS, UL & NSF
RSF76Y050TV	PPS	25VA	50cm ETFE 19/0.2	Viton	WRAS, UL & NSF
RSF76Y100TV	PPS	25VA	100cm ETFE 19/0.2	Viton	WRAS, UL & NSF
RSF76Y100RN	PPS	25VA	100cm PVC 16/0.2	Nitrile	WRAS, UL & NSF
RSF77Y100GN	PVDF	25VA	100cm PTFE 7/0.2	Nitrile	UL & NSF
RSF77H100GN	PVDF	100VA	100cm PTFE 7/0.2	Nitrile	UL & NSF
RSF77Y100GV	PVDF	25VA	100cm PTFE 7/0.2	Viton	UL & NSF
RSF77H100GV	PVDF	100VA	100cm PTFE 7/0.2	Viton	UL & NSF
RSF78H100RN	PP (UL)	100VA	100cm PVC 16/0.2	Nitrile	UL
RSF78Y100RN	PP (UL)	25VA	100cm PVC 16/0.2	Nitrile	UL
RSF73HNP	Nylon	100VA	M12 connector	Nitrile	WRAS
RSF73YNP	Nylon	25VA	M12 connector	Nitrile	WRAS
RSF74HNP	Polypropylene	100VA	M12 connector	Nitrile	WRAS & NSF
RSF74YNP	Polypropylene	25VA	M12 connector	Nitrile	WRAS & NSF
RSF76HNP	PPS	100VA	M12 connector	Nitrile	WRAS, UL & NSF
RSF76YNP	PPS	25VA	M12 connector	Nitrile	WRAS, UL & NSF
RSF77HNP	PVDF	100VA	M12 connector	Nitrile	UL & NSF
RSF77YNP	PVDF	25VA	M12 connector	Nitrile	UL & NSF
RSF77HVP	PVDF	100VA	M12 connector	Viton	UL & NSF
RSF77YVP	PVDF	25VA	M12 connector	Viton	UL & NSF
RSF78HNP	PP (UL)	100VA	M12 connector	Nitrile	UL
RSF78YNP	PP (UL)	25VA	M12 connector	Nitrile	UL

Custom versions can be made for particular applications. Please contact Sensata with your requirements.



DIMENSIONS

All dimensions are in millimeters.

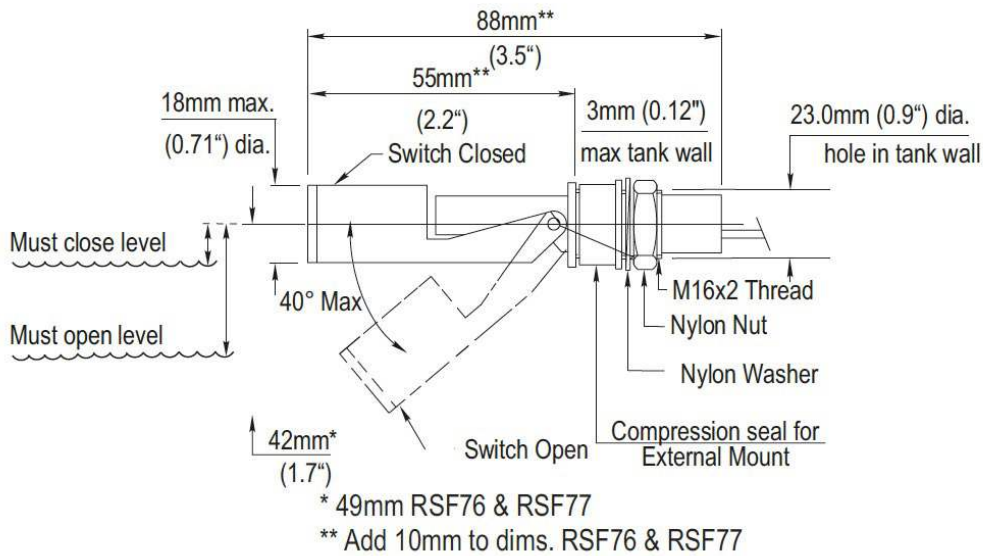

Electrical Connections

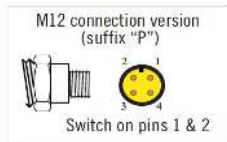

Made in the UK

Page 3

Sensata Technologies, Inc. ("Sensata") data sheets are solely intended to assist designers ("Buyers") who are developing systems that incorporate Sensata products (also referred to herein as "components"). Buyer understands and agrees that Buyer remains responsible for using its independent analysis, evaluation and judgment in designing Buyer's systems and products. Sensata data sheets have been created using standard laboratory conditions and engineering practices. Sensata has not conducted any testing other than that specifically described in the published documentation for a particular data sheet. Sensata may make corrections, enhancements, improvements and other changes to its data sheets or components without notice.

Buyers are authorized to use Sensata data sheets with the Sensata component(s) identified in each particular data sheet. HOWEVER, NO OTHER LICENSE, EXPRESS OR IMPLIED, BY ESTOPPEL OR OTHERWISE TO ANY OTHER SENSATA INTELLECTUAL PROPERTY RIGHT, AND NO LICENSE TO ANY THIRD PARTY TECHNOLOGY OR INTELLECTUAL PROPERTY RIGHT, IS GRANTED HEREIN. SENSATA DATA SHEETS ARE PROVIDED "AS IS". SENSATA MAKES NO WARRANTIES OR REPRESENTATIONS WITH REGARD TO THE DATA SHEETS OR USE OF THE DATA SHEETS, EXPRESS, IMPLIED OR STATUTORY, INCLUDING ACCURACY OR COMPLETENESS. SENSATA DISCLAIMS ANY WARRANTY OF TITLE AND ANY IMPLIED WARRANTIES OF MERCHANTABILITY, FITNESS FOR A PARTICULAR PURPOSE, QUIET ENJOYMENT, QUIET POSSESSION, AND NON-INFRINGEMENT OF ANY THIRD PARTY INTELLECTUAL PROPERTY RIGHTS WITH REGARD TO SENSATA DATA SHEETS OR USE THEREOF.

All products are sold subject to Sensata's terms and conditions of sale supplied at www.sensata.com SENSATA ASSUMES NO LIABILITY FOR APPLICATIONS ASSISTANCE OR THE DESIGN OF BUYERS' PRODUCTS. BUYER ACKNOWLEDGES AND AGREES THAT IT IS SOLELY RESPONSIBLE FOR COMPLIANCE WITH ALL LEGAL, REGULATORY AND SAFETY-RELATED REQUIREMENTS CONCERNING ITS PRODUCTS, AND ANY USE OF SENSATA COMPONENTS IN ITS APPLICATIONS, NOTWITHSTANDING ANY APPLICATIONS-RELATED INFORMATION OR SUPPORT THAT MAY BE PROVIDED BY SENSATA.

Mailing Address: Sensata Technologies, Inc., 529 Pleasant Street, Attleboro, MA 02703, USA.

CONTACT US

+44 (0)1202 897969
 c3w_sales@sensata.com
 Cynergy3 Components Ltd.
 7 Cobham Road,
 Ferndown Industrial Estate,
 Wimborne, Dorset,
 BH21 7PE, United Kingdom