

DRAWING MADE IN AMERICAN PROJECTION

© 1961 BY AMP INCORPORATED. ALL RIGHTS RESERVED. AMP PRODUCTS COVERED BY PATENTS AND/OR PATENTS PENDING.

REVISIONS				
ZONE	LTR	DESCRIPTION	DATE	APPROVED
	E	REDRAWN & REVISED 2078	4-15-69	M.S. L.H.
	F	OBSOLETE 66071-2 PER ECN 3341	2-4-72	J.W. D.H.
	G	PRINT DIST WAS "39" LOC WAS "AB" 9347	10-72	CO
	H	BRIGHT TIN-LEAD WAS TIN EA 1818	6-18-81	DS

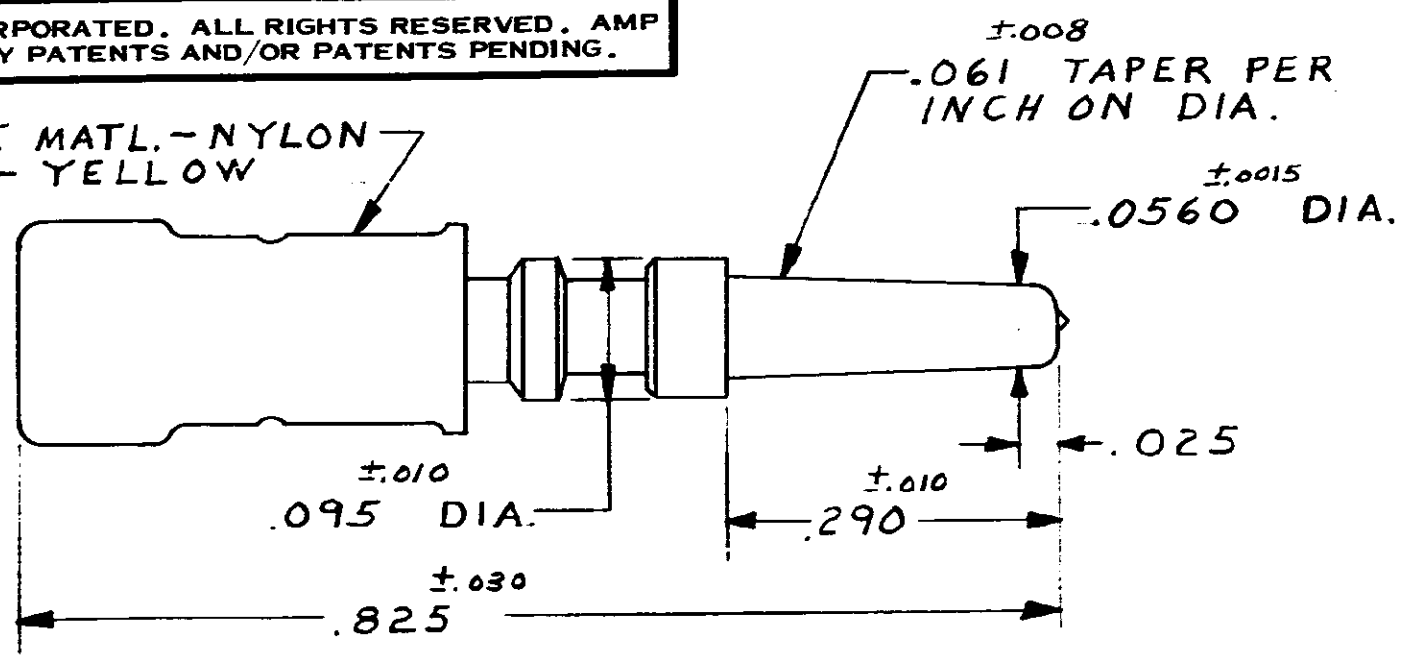

WIRE SIZE : # 24 - # 22
INS. RANGE : .040 - .080

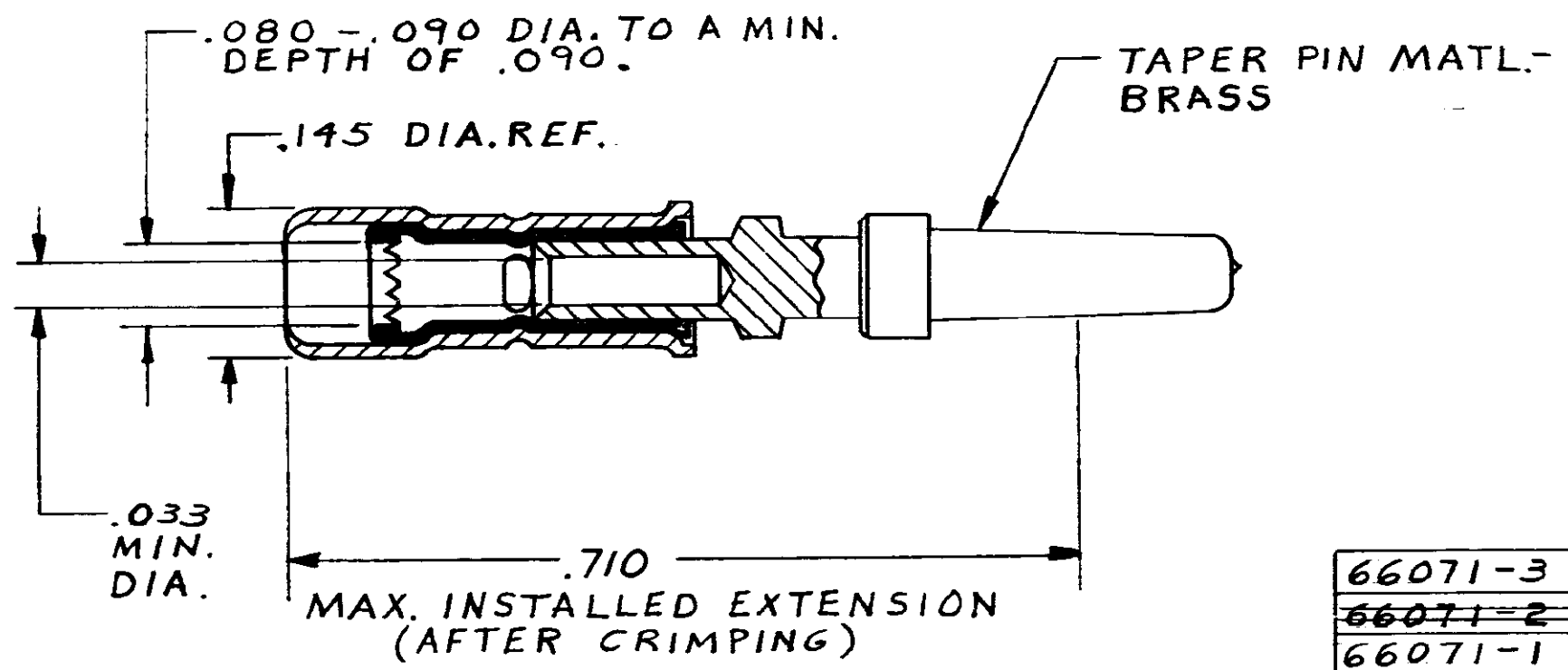

ASSY. BEFORE CRIMPING

66071-3	.000030 GOLD OVER .000050 NICKEL
66071-2	SILVER - .0002 THICK
66071-1	BRIGHT TIN-LEAD .0002 THICK
PART NO.	FINISH
UNLESS OTHERWISE SPECIFIED DIMENSIONS ARE IN INCHES TOLERANCES ON: DECIMALS ± .015 ANGLES ± #	CONTRACT NO. 4-15-69
MATERIAL SEE CALLOUT	DR. <i>M. Smith</i>
	CHK. <i>D.S. Heide</i> 5-12-69
	APPD. <i>C. Snyder</i> 5/15/69
	REL. <i>W. Fell</i> 5-15-69
DSGN APPD	OTHER APPD
AMP INCORPORATED HARRISBURG, PENNSYLVANIA	NAME PIN, TAPER, 53" SERIES, P.I.D.G.
SIZE B	CODE IDENT NO. 00779
SCALE #	NUMBER 66071
	SHEET

CUSTOMER DRAWING

PRINT DIST 12 H