

P	LTR	DESCRIPTION	DATE	DWN	APVD
	H	EC 0G3B-0317-03	24APR03	VF	GS
	J	REVISED PER ECO-17-009773	06JUL2017	RS	MZ

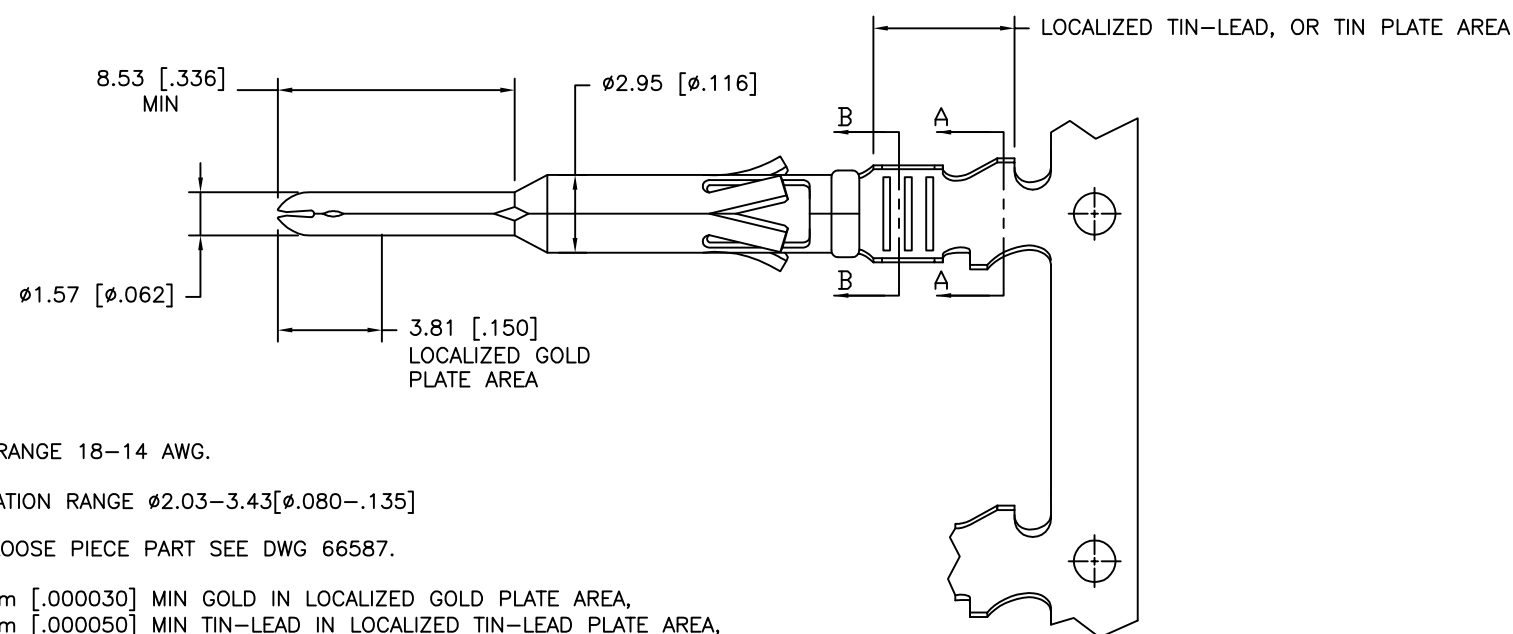
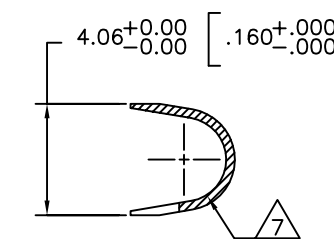
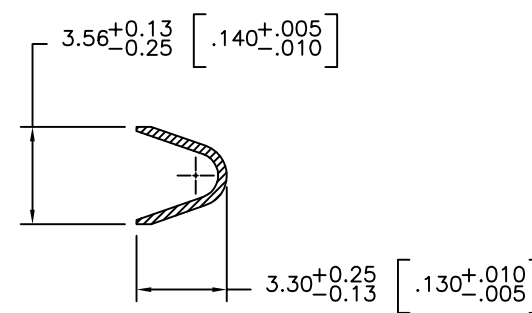
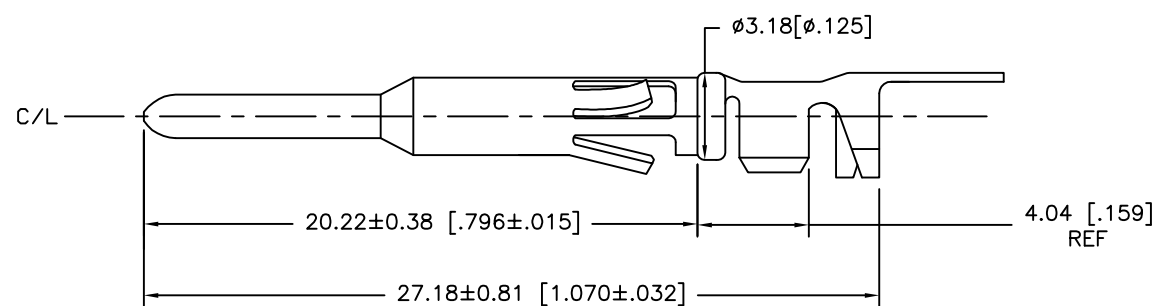
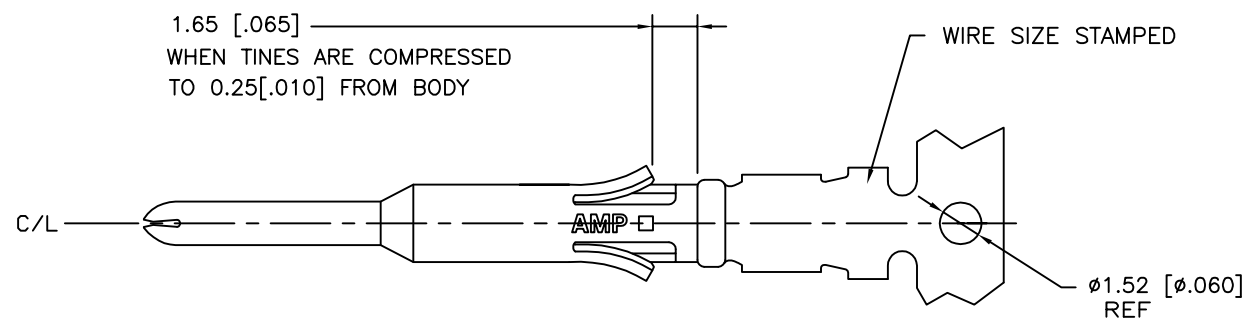

- 1 WIRE RANGE 18-14 AWG.
- 2 INSULATION RANGE Ø2.03-3.43[Ø.080-.135]
- 3 FOR LOOSE PIECE PART SEE DWG 66587.
- 4 0.76µm [.000030] MIN GOLD IN LOCALIZED GOLD PLATE AREA,
1.27µm [.000050] MIN TIN-LEAD IN LOCALIZED TIN-LEAD PLATE AREA,
BOTH OVER 1.27µm [.000050] MIN NICKEL.
- 5 TIN PLATED.
- 6 GOLD PLATING PER MIL-G-45204, TIN PER MIL-T-10727
AND NICKEL PER QQ-N-290.
- 7 Ø2.03-2.67[Ø.080-.105] INSULATION CRIMP WILL BE 3.05[.120] "O" CRIMP,
Ø2.67-3.43[Ø.105-.135] INSULATION CRIMP WILL BE 3.56[.140] "O" CRIMP.
- 8 0.76µm [.000030] MIN GOLD IN LOCALIZED GOLD PLATE AREA,
1.27µm [.000050] MIN TIN IN LOCALIZED TIN PLATE AREA,
BOTH OVER 1.27µm [.000050] MIN NICKEL.

OBsolete	REVERSE REELED FOR MINI-APPLICATOR	8	66577-7
	REVERSE REELED FOR MINI-APPLICATOR	4	66577-4
OBsolete	-	4	66577-3
	REVERSE REELED FOR MINI-APPLICATOR	5	66577-2
	-	5	66577-1
	DESCRIPTION	FINISH	PART NUMBER

THIS DRAWING IS A CONTROLLED DOCUMENT.		DWN V. FURLER 12MAY03	TE Connectivity	
DIMENSIONS: mm [INCHES]		CHK G. STEINHAUER 12MAY03		
TOLERANCES UNLESS OTHERWISE SPECIFIED:		APVD G. STEINHAUER 12MAY03	NAME	
0 PLC ± - 1 PLC ± - 2 PLC ± 0.13 [.005] 3 PLC ± - 4 PLC ± - ANGLES ± -		PRODUCT SPEC	CONTACT, PIN, STRIP, TYPE VI, MULTIMATE	
MATERIAL BRASS MIL-C-50		FINISH SEE TABLE 6	APPLICATION SPEC	RESTRICTED TO
		WEIGHT -	SIZE A3	CAGE CODE 00779
			DRAWING NO C-66577	SCALE 8.5:1
			SHEET 1 OF 1	REV J
			CUSTOMER DRAWING	