

SF2198E

**806 MHz
SAW Filter**

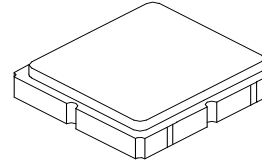

SM3030-6

- **Surface Mount 3.0 x 3.0 mm Package**
- **Complies with Directive 2002/95/EC (RoHS)**
- **Moisture Sensitivity Level: 1**

Absolute Maximum Ratings

Rating	Value	Units
Input Power Level	10	dBm
DC Voltage on any Non-ground Terminal	3	V
Operating Temperature Range	-40 to +85	°C
Storage Temperature Range in Tape and Reel	-40 to +85	°C
Maximum Soldering Profile, 5 cycles/10 seconds maximum	265	°C

Electrical Characteristics

Characteristic	Sym	Notes	Min	Typ	Max	Units			
Center Frequency	f_C			806		MHz			
Insertion Loss	IL	791 to 821 MHz		2.9	4.5	dB			
		800 to 812 MHz		2.3	3.0				
		805 to 806 MHz		1.8	2.5				
Amplitude Ripple, 791 to 821 MHz				1.3	3.0				
VSWR, 791 to 821 MHz				1.7	2.5				
Attenuation, 0 dB Reference:						dB			
							DC to 760 MHz	45	55
							760 to 775 MHz	30	48
							832 to 862 MHz	8	15
							862 to 900 MHz	30	39
							900 to 1500 MHz	45	57
1500 to 2000 MHz	35	45							
Source Impedance	Z_S			50		Ω			
Load Impedance	Z_L			50					
Case Style	SM3030-6 3.0 x 3.0 mm Nominal Footprint								
Lid Symbolization (Y=year, WW=week, S=shift) dot=pin 1 indicator	928, <u>YWWS</u>								

Electrical Connections

Connection	Terminals
Input	2
Output	5
Case Ground	All others

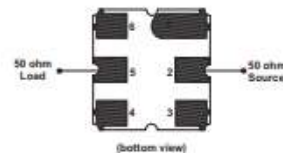

(bottom view)

CAUTION: Electrostatic Sensitive Device. Observe precautions for handling.

NOTES:

1. The design, manufacturing process, and specifications of this device are subject to change.
2. US or International patents may apply.
3. RoHS compliant from the first date of manufacture.

Filter Response Plots

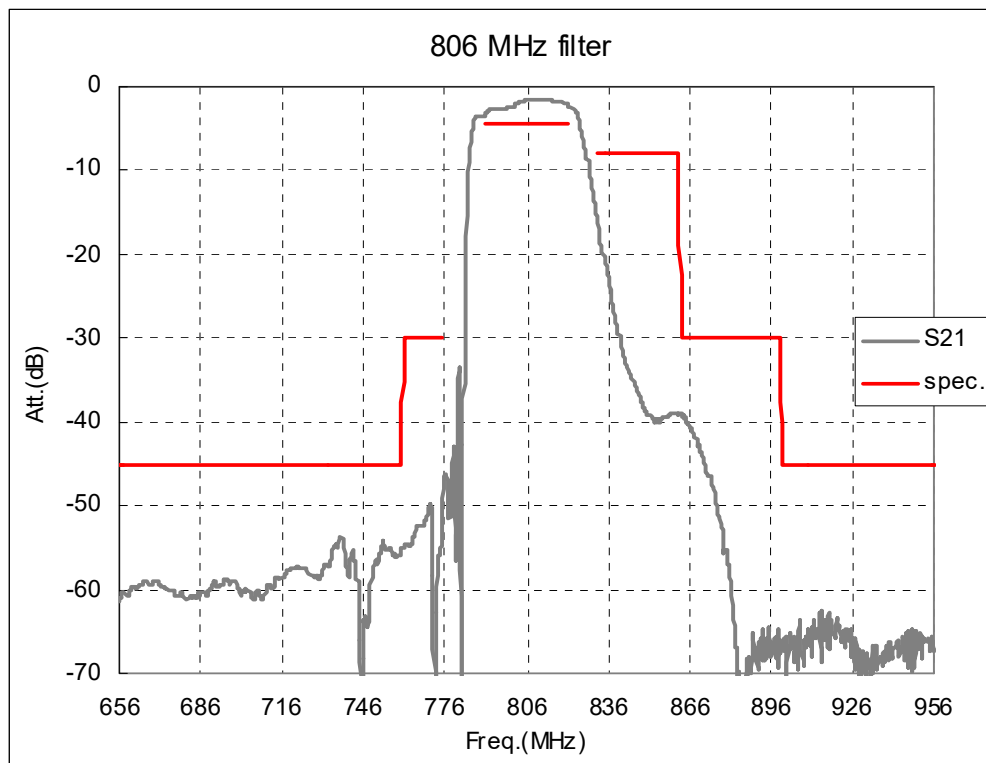
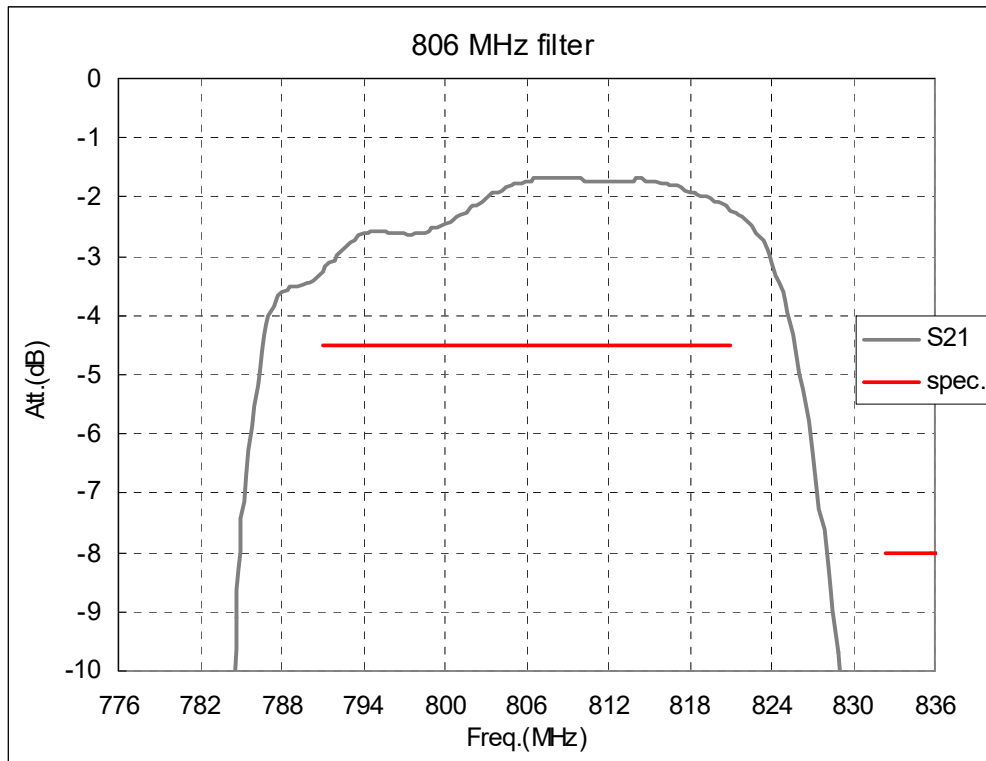

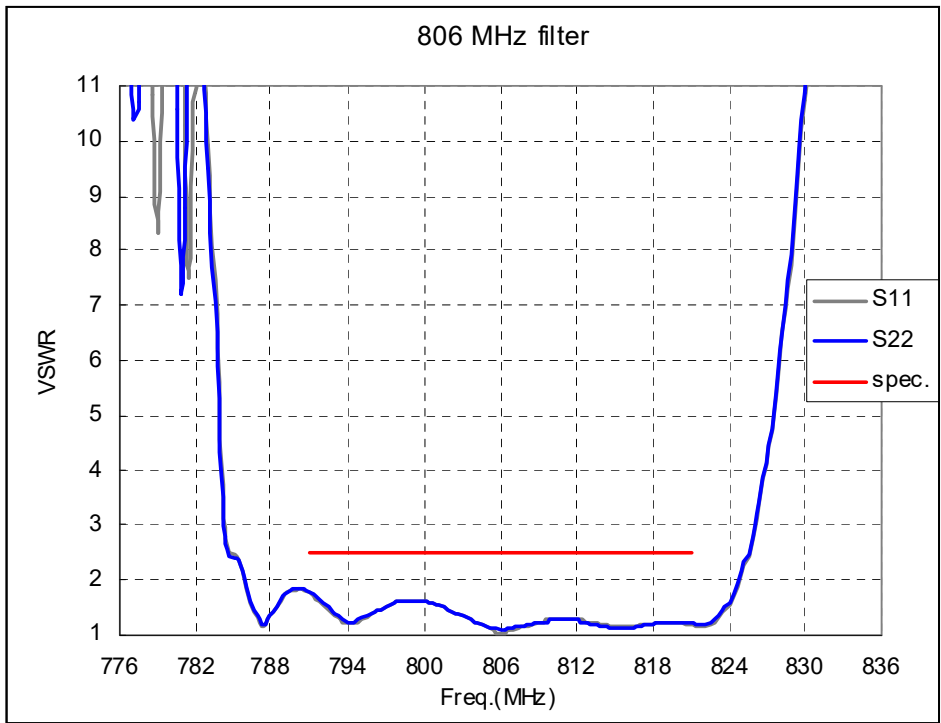
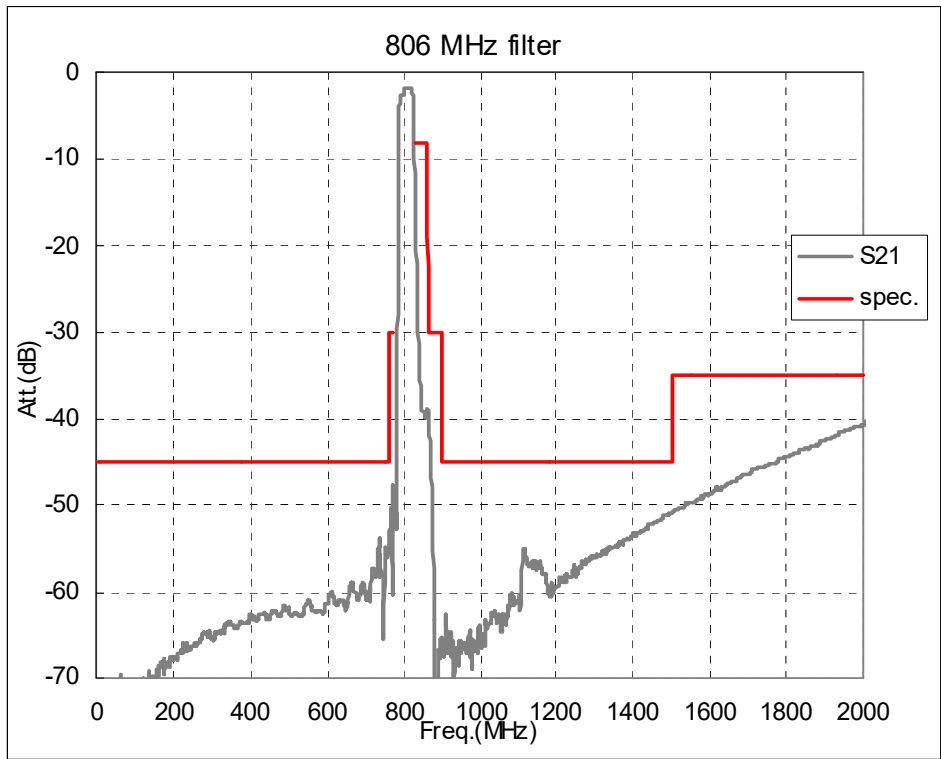

SM3030-6 Case

6-Terminal Ceramic Surface-Mount Case 3.0 X 3.0 mm Nominal Footprint

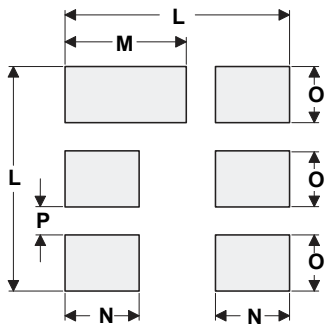
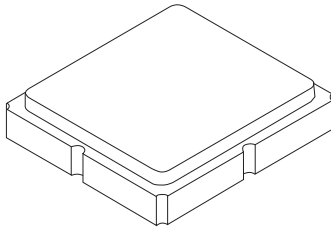

PCB Footprint Top View

Case and PCB Footprint Dimensions

Dimension	mm			Inches		
	Min	Nom	Max	Min	Nom	Max
A	2.87	3.00	3.13	0.113	0.118	0.123
B	2.87	3.00	3.13	0.113	0.118	0.123
C	1.12	1.25	1.38	0.044	0.049	0.054
D	0.77	0.90	1.03	0.030	0.035	0.040
E	2.67	2.80	2.93	0.105	0.110	0.115
F	1.47	1.60	1.73	0.058	0.063	0.068
G	0.72	0.85	0.98	0.028	0.033	0.038
H	1.37	1.50	1.63	0.054	0.059	0.064
I	0.47	0.60	0.73	0.019	0.024	0.029
J	1.17	1.30	1.43	0.046	0.051	0.056
K	0.62	0.75	0.88	0.024	0.029	0.034
L		3.20			0.126	
M		1.70			0.067	
N		1.05			0.041	
O		0.81			0.032	
P		0.38			0.015	

Case Materials

Materials	
Solder Pad Plating	0.3 to 1.0 μm Gold over 1.27 to 8.89 μm Nickel
Lid Plating	2.0 to 3.0 μm Nickel
Body	Al_2O_3 Ceramic

TOP VIEW

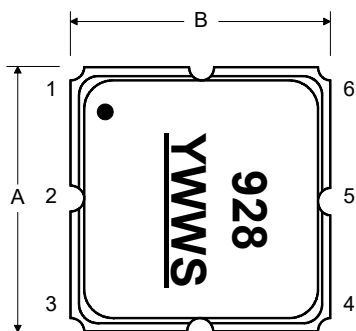

BOTTOM VIEW

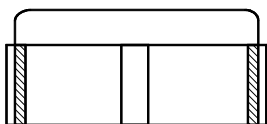
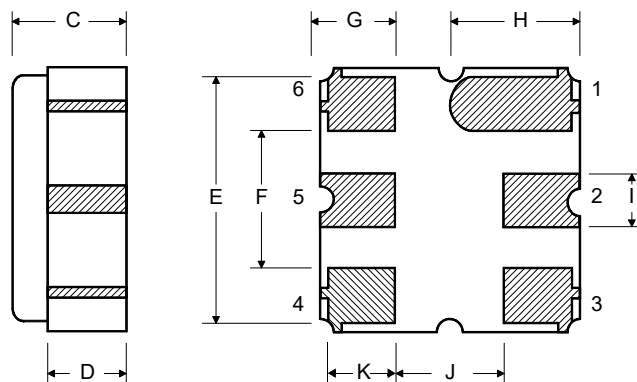

Tape and Reel Specifications

Tape and Reel Standard per ANSI/EIA-481

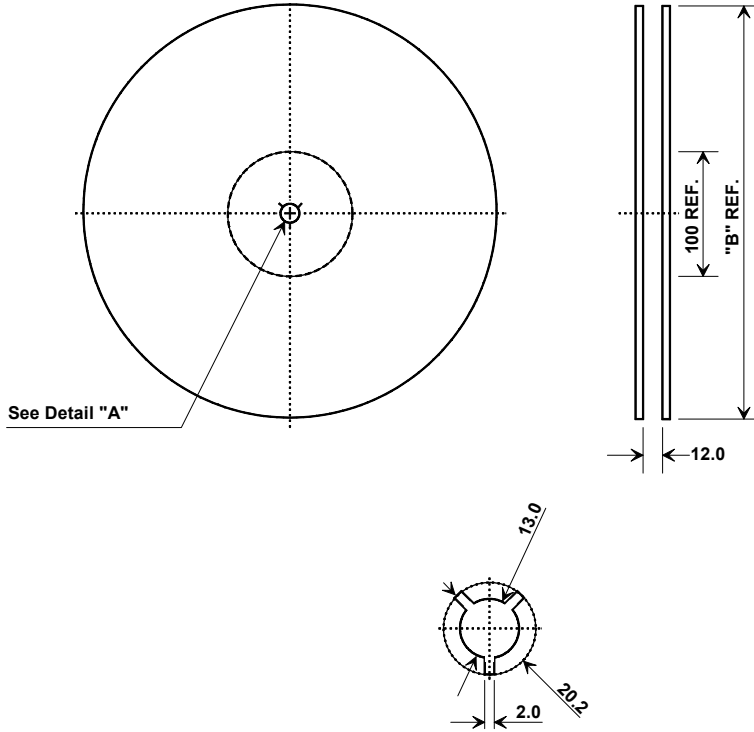

"B"		Quantity Per Reel
Inches	millimeters	
7	178	500
13	330	3000

COMPONENT ORIENTATION and DIMENSIONS

Carrier Tape Dimensions	
Ao	3.35 mm
Bo	3.35 mm
Ko	1.40 mm
Pitch	8.0 mm
W	12.0 mm

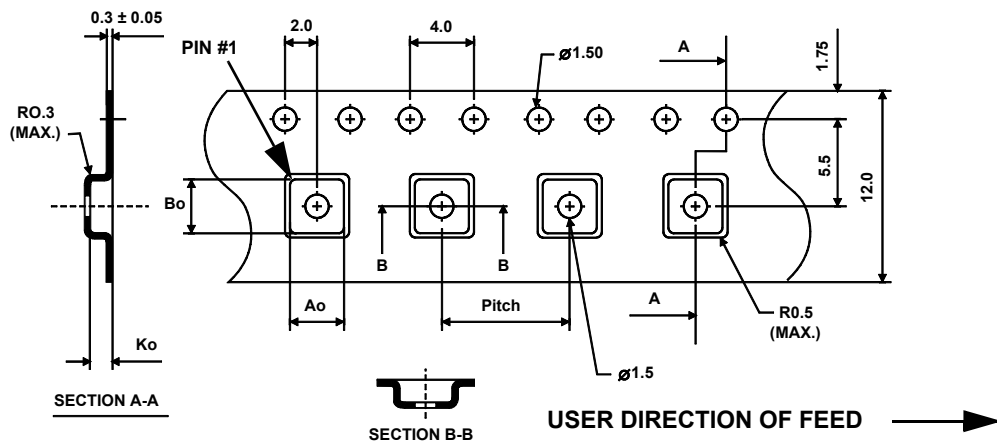

Recommended Reflow Profile

1. Preheating shall be fixed at 150~180°C for 60~90 seconds.
2. Ascending time to preheating temperature 150°C shall be 30 seconds min.
3. Heating shall be fixed at 220°C for 50~80 seconds and at 260°C +0/-5°C peak (10 seconds).
4. Time: 5 times maximum.

