

**Ratings**

Voltage: 150 V  
 Temperature: -40~70 °C

**Conductor**

Conductor count: 6  
 Gauge: 24 AWG 0.21 mm<sup>2</sup>  
 Material: Tinned copper strands  
 Strand size:  $\varnothing 0.08 \times 41$   
 Resistance at 20 °C: 95  $\Omega$  /km Max

**Insulator**

Material: HDPE  
 Color: red, black, white, yellow, blue, green  
 Diameter:  $\varnothing 1.05 \pm 0.10$  mm  
 Nominal thickness: 0.22 mm  
 Resistance at 20 °C: 100 M $\Omega$  /km Min

**Wrap**

Material: cotton paper

**Filler**

Material: aramid fiber

**Outer jacket**

Material: TPU  
 Color: white  
 Diameter:  $\varnothing 4.5 \pm 0.25$  mm  
 Nominal thickness: 0.6 mm

**Tests**

Tensile strength: 26 kgf min  
 Dielectric test: 1500 V dc for 1 minute without breakdown  
 Bend test at 200 g,  $\pm 60^\circ$ , 30 cycles /min: 15,000 cycle minimum

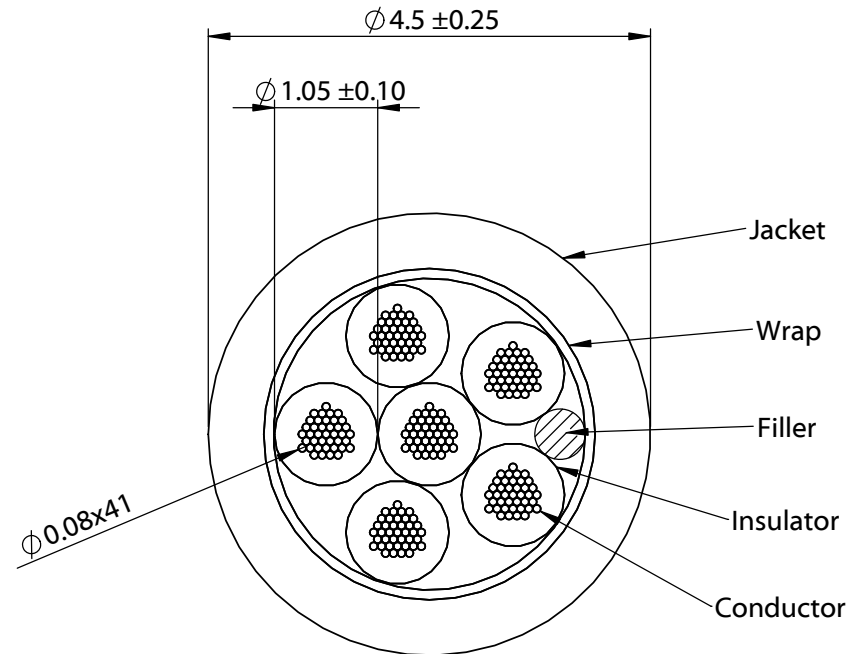
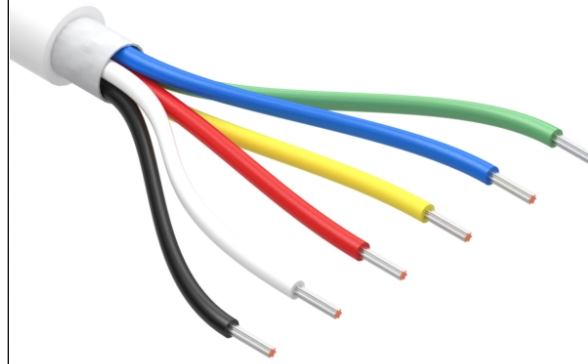

Revision:	Date:	Description:
A	9/12/2022	Initial release

Prepared: **MP**  
Digitally signed by MP  
 Date: 2022.09.15 15:53:15 -07'00'

Verified: **PB**  
Digitally signed by PB  
 Date: 2022.09.22 11:27:28 -07'00'

Dimensions are in millimeters.  
 Tolerances:  
 X:  $\pm 0.5$  mm  
 X.X:  $\pm 0.3$  mm  
 X.XX:  $\pm 0.05$  mm

Notes:  
 RoHS compliant  
 Jacket meets ISO 10993 Biological Compatibility  
 Phthalate and halogen free  
 Function test: no open, no short, no intermittent

Description:  
 Wire, 6C TS, 24 AWG, 150V, 70C, 4.5 mm, TPU, 75A, white, WBL

# TENSILITY

tel 1.541.323.3228 800 877.670.7118  
 fax 1.541.323.4202 web tensility.com

Size:	Part number:
A	30-02809
Scale: 13:1	Sheet 1 of 1