

LOC		DIST		REVISIONS			
P	LTR	DESCRIPTION	DATE	DN	APVD		
E	4	REVISED PER ECO-10-001916	02FEB2010	JY	SY		
F		ECR-10-018652	10SEP10	JS	MQW		
G		ECO-11-024491	13DEC11	SY	MQW		
H		ECR-12-010544	05DEC12	SY	AC		

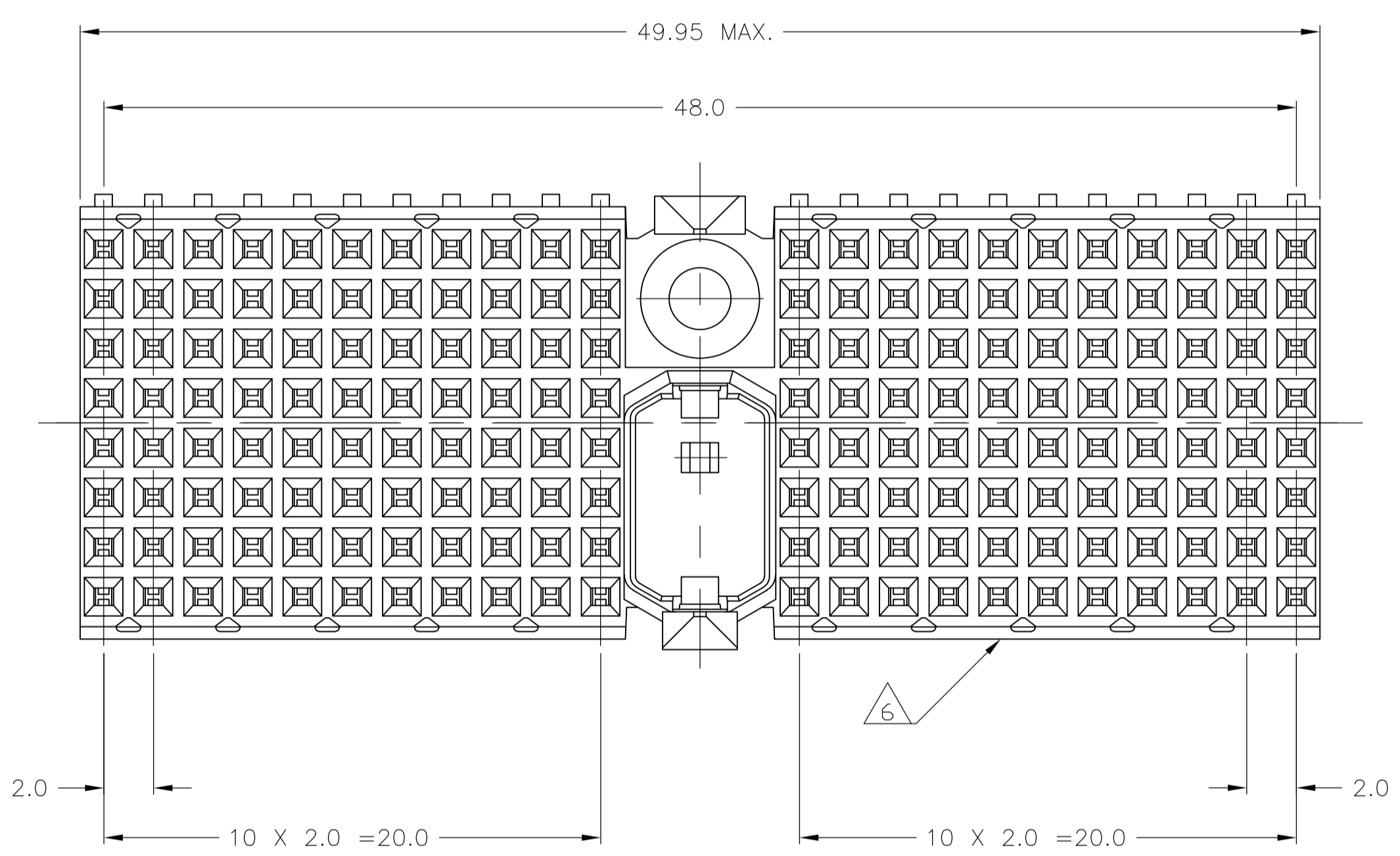

PLATED THRU HOLE PARAMETERS
 REFERENCE APPLICATION SPECIFICATION

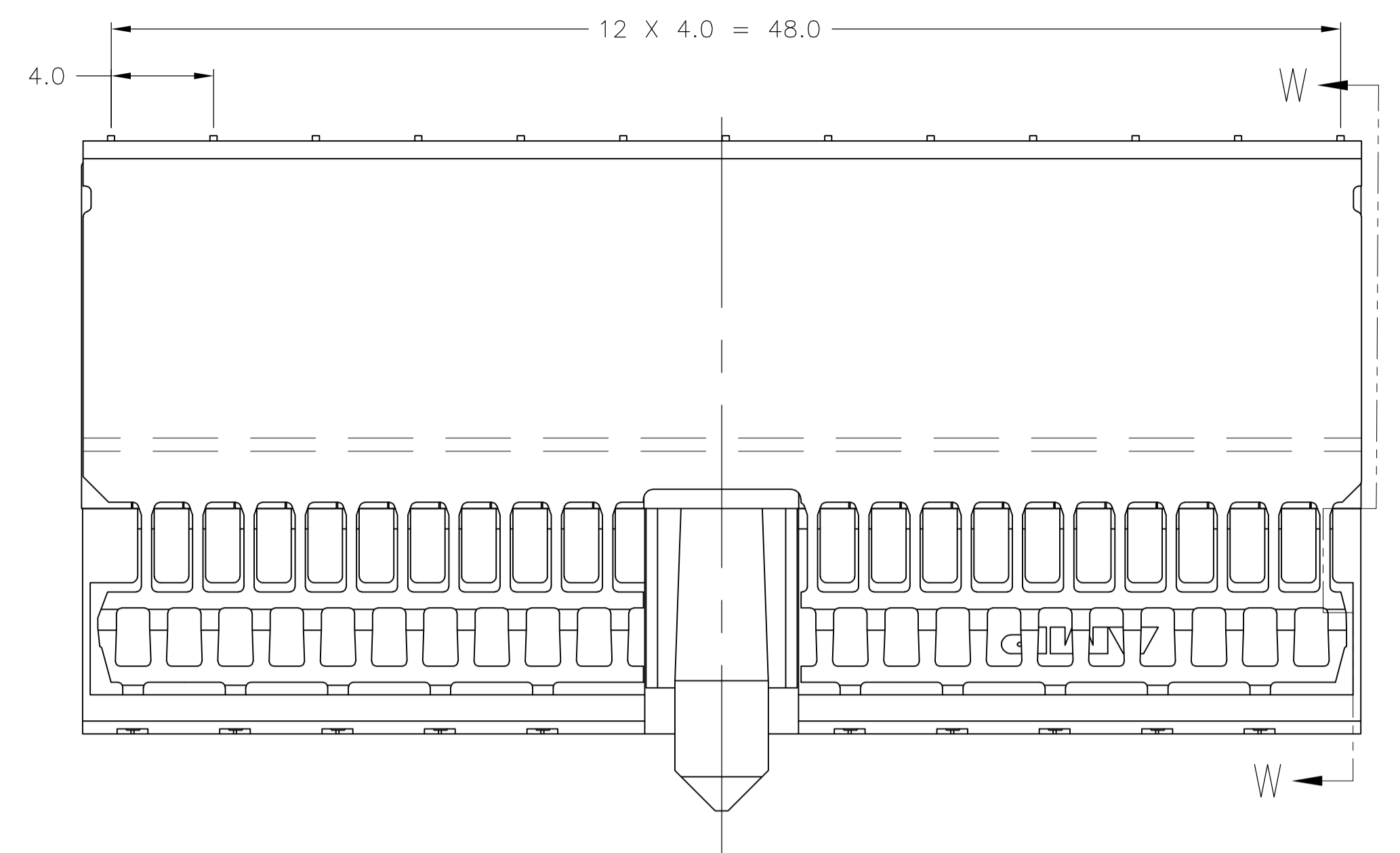
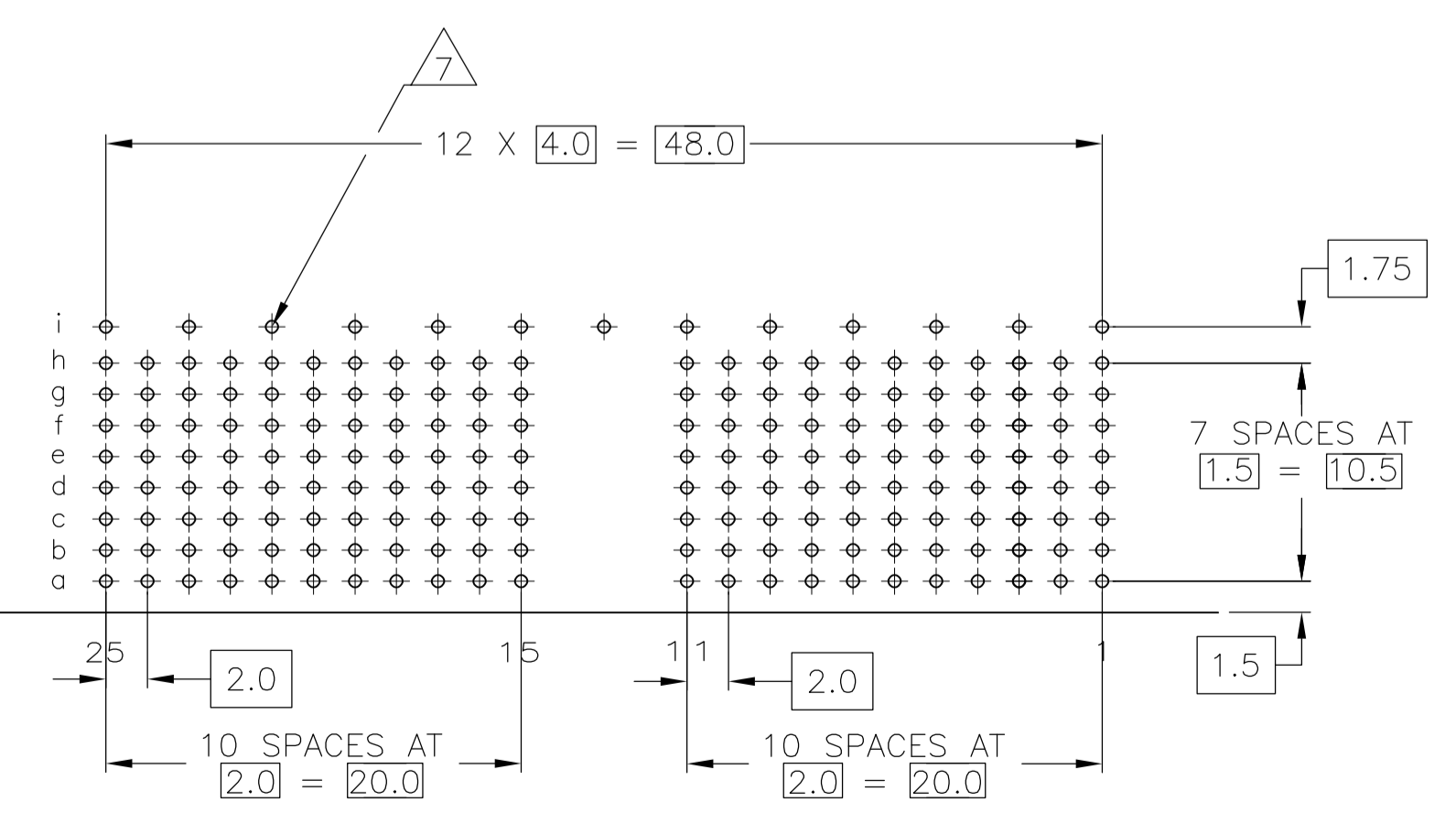

EDGE OF P.C. BOARD
 RECOMMENDED PCB-HOLE LAYOUT
 COMPONENT SIDE SHOWN
 SCALE 3:1

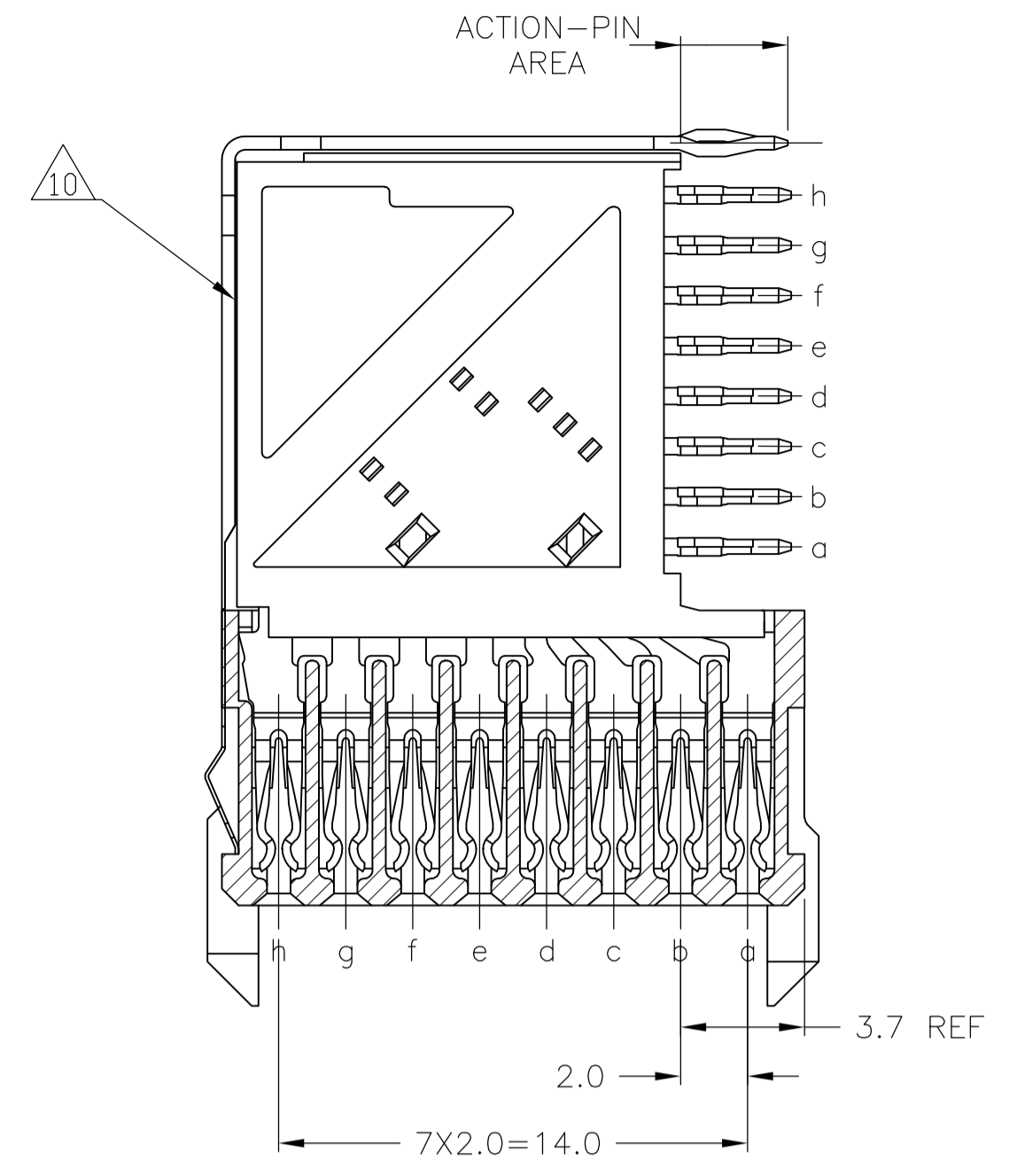

SECTION W-W

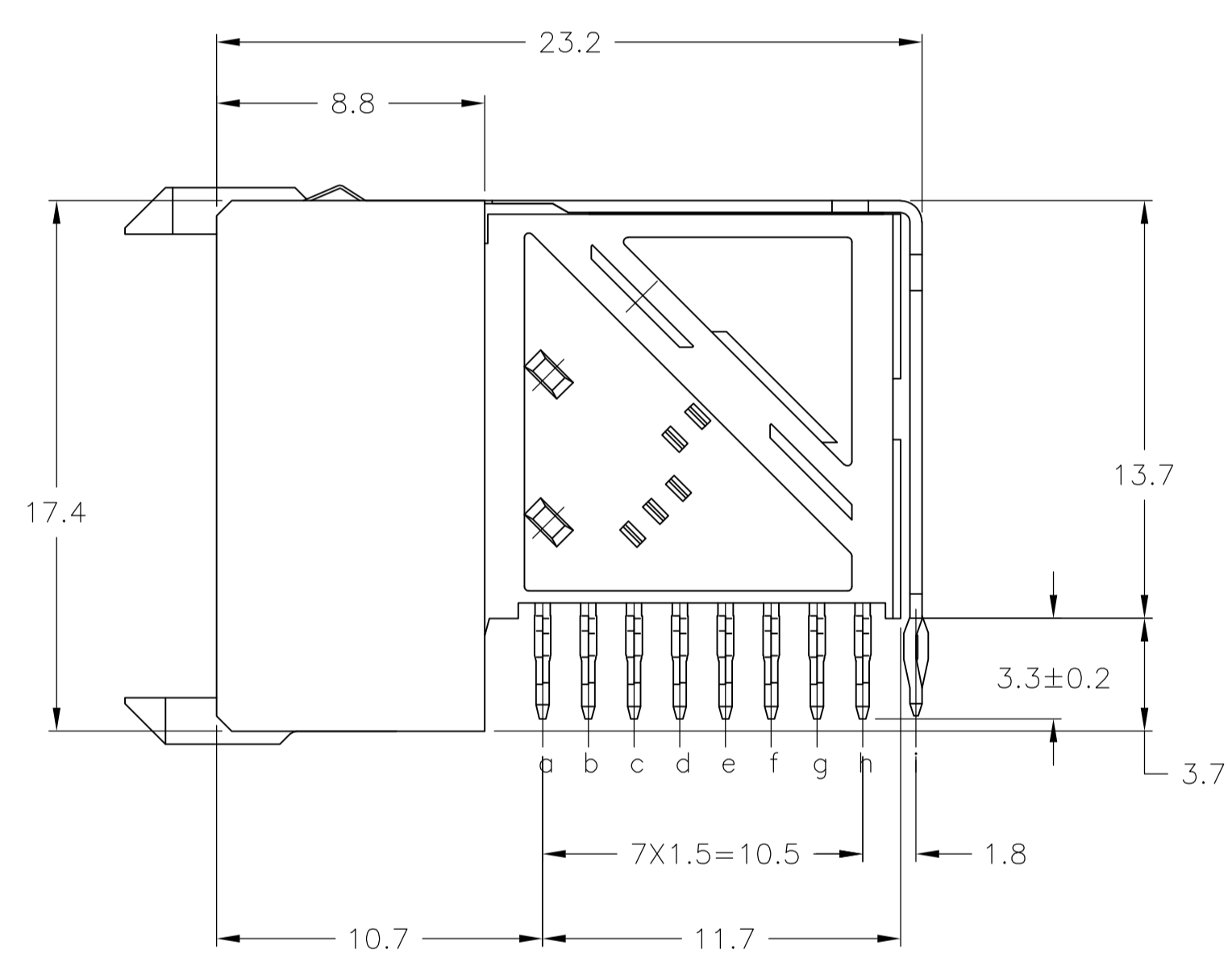

- 1 MATERIAL:
CONTACT: PHOSPHOR BRONZE.
HOUSING: GLASS-FILLED POLYESTER.
- 2 GENERAL PLATING SPECIFICATION: UNDERPLATING (ENTIRE CONTACT): 1.27µm MIN NICKEL AND ACTION PIN: 0.5µm MIN TIN/LEAD. FOR PLATING OF MATING SURFACES SEE APPLICABLE SPECIFICATION REFERENCE FOR EACH DASH NUMBER.
- 3 CONFORMS TO ALL TESTING ACCORDING TO IEC 61076-4-101 PERFORMANCE LEVEL 2.
- 4 CONNECTOR TESTED AND QUALIFIED AGAINST TELCORDIA GR-1217-CORE QUALITY LEVEL 3, CENTRAL OFFICE APPLICATIONS.
- 5 CONNECTOR TESTED AND QUALIFIED AGAINST TELCORDIA GR-1217-CORE QUALITY LEVEL 3, UNCONTROLLED ENVIRONMENT APPLICATIONS.
- 6 CONNECTOR MARKED WITH PART NUMBER AND DATE CODE. ADDITIONAL CHARACTERS OR MARKINGS, AS WELL AS THE LOCATION OF THE MARKINGS, MAY BE ADDED FOR TRACEABILITY BASED UPON MANUFACTURERS DISCRETION.
- 7 PLATED-THROUGH HOLES AT 2x1.5mm GRID 176 TOTAL HOLES.
- 8 ROW "i" 13 PLATED THROUGH HOLES FOR UPPERSHIELD.
- 9 CONNECTOR & SHIELD LUBRICATED WITH BELCORE APPROVED LUBRICANT, TECHNICAL REFERENCE: TR-NWT-001217 ISSUE 1, SEP 1992.
- 10 SHIELD MOUNTED ON CONNECTOR WITH DOUBLE SIDED ADHESIVE TAPE OR ADHESIVE.
- 11 OBSOLETE PARTS: OBSOLETE CIS STREAMLINING PER D.RENAUD/D.SINISI
- 12 0.76µm MIN GOLD PLATING AT MATING SURFACES.

	2 3 12	3-646486-0
11 OBSOLETE	2 5 9	-1-646486-9-
OBSOLETE	2 4 9	646486-9
OBSOLETE	2 3	646486-1
	FINISH	PART NUMBER

THIS DRAWING IS A CONTROLLED DOCUMENT.

DIMENSIONS: mm	TOLERANCES UNLESS OTHERWISE SPECIFIED:	DIN B CARBO 06DEC05	06DEC05	Tyco Electronics Corporation Harrisburg, PA 17105-3608
0-PLG ±	±0.2	CHK G SKIPPER	06DEC05	APVD G SKIPPER 06DEC05
1-PLG ±0.1		PRODUCT SPEC		NAME R/A RECEPTACLE ASSY, 176 POSN
2-PLG ±		APPLICATION SPEC		Z-PACK 2mm HM, TYPE D
3-PLG ±		114-19029		W/GROUND RETURN SHIELD
4-PLG ±		114-19029		SIZE CAGE CODE DRAWING NO
ANGLES ±		114-19029		RESTRICTED TO
MATERIAL 1	FINISH SEE TABLE	WEIGHT	A1 00779 C=646486	SCALE 5:1 SHEET 1 of 1 REV H
		CUSTOMER DRAWING		