

ZG2100M/ZG2101M
Wi-Fi[®] Module
Data Sheet

2.4 GHz 802.11b Low Power
Transceiver Module

Note the following details of the code protection feature on Microchip devices:

- Microchip products meet the specification contained in their particular Microchip Data Sheet.
- Microchip believes that its family of products is one of the most secure families of its kind on the market today, when used in the intended manner and under normal conditions.
- There are dishonest and possibly illegal methods used to breach the code protection feature. All of these methods, to our knowledge, require using the Microchip products in a manner outside the operating specifications contained in Microchip's Data Sheets. Most likely, the person doing so is engaged in theft of intellectual property.
- Microchip is willing to work with the customer who is concerned about the integrity of their code.
- Neither Microchip nor any other semiconductor manufacturer can guarantee the security of their code. Code protection does not mean that we are guaranteeing the product as "unbreakable."

Code protection is constantly evolving. We at Microchip are committed to continuously improving the code protection features of our products. Attempts to break Microchip's code protection feature may be a violation of the Digital Millennium Copyright Act. If such acts allow unauthorized access to your software or other copyrighted work, you may have a right to sue for relief under that Act.

Information contained in this publication regarding device applications and the like is provided only for your convenience and may be superseded by updates. It is your responsibility to ensure that your application meets with your specifications. MICROCHIP MAKES NO REPRESENTATIONS OR WARRANTIES OF ANY KIND WHETHER EXPRESS OR IMPLIED, WRITTEN OR ORAL, STATUTORY OR OTHERWISE, RELATED TO THE INFORMATION, INCLUDING BUT NOT LIMITED TO ITS CONDITION, QUALITY, PERFORMANCE, MERCHANTABILITY OR FITNESS FOR PURPOSE. -Microchip disclaims all liability arising from this information and its use. Use of Microchip devices in life support and/or safety applications is entirely at the buyer's risk, and the buyer agrees to defend, indemnify and hold harmless Microchip from any and all damages, claims, suits, or expenses resulting from such use. No licenses are conveyed, implicitly or otherwise, under any Microchip -intellectual property rights.

QUALITY MANAGEMENT SYSTEM
CERTIFIED BY DNV
== ISO/TS 16949:2002 ==

Trademarks

The Microchip name and logo, the Microchip logo, dsPIC, KEELOQ, KEELOQ logo, MPLAB, PIC, PICmicro, PICSTART, PIC³² logo, rfPIC and UNI/O are registered trademarks of Microchip Technology Incorporated in the U.S.A. and other countries.

FilterLab, Hampshire, HI-TECH C, Linear Active Thermistor, MXDEV, MXLAB, SEEVAL and The Embedded Control Solutions Company are registered trademarks of Microchip Technology Incorporated in the U.S.A.

Analog-for-the-Digital Age, Application Maestro, CodeGuard, dsPICDEM, dsPICDEM.net, dsPICworks, dsSPEAK, ECAN, ECONOMONITOR, FanSense, HI-TIDE, In-Circuit Serial Programming, ICSP, Mindi, MiWi, MPASM, MPLAB Certified logo, MPLIB, MPLINK, mTouch, Octopus, Omniscient Code Generation, PICC, PICC-18, PICDEM, PICDEM.net, PICKit, PICtail, REAL ICE, rLAB, Select Mode, Total Endurance, TSHARC, UniWinDriver, WiperLock and ZENA are trademarks of Microchip Technology Incorporated in the U.S.A. and other countries.

SQTP is a service mark of Microchip Technology Incorporated in the U.S.A.

All other trademarks mentioned herein are property of their respective companies.

© 2010, Microchip Technology Incorporated, Printed in the U.S.A., All Rights Reserved.

 Printed on recycled paper.

ISBN: 978-1-60932-064-5

Microchip received ISO/TS-16949:2002 certification for its worldwide headquarters, design and wafer fabrication facilities in Chandler and Tempe, Arizona; Gresham, Oregon and design centers in California and India. The Company's quality system processes and procedures are for its PIC[®] MCUs and dsPIC[®] DSCs, KEELOQ[®] code hopping devices, Serial EEPROMs, microperipherals, nonvolatile memory and analog products. In addition, Microchip's quality system for the design and manufacture of development systems is ISO 9001:2000 certified.

2.4 GHz 802.11b Low Power Transceiver Module

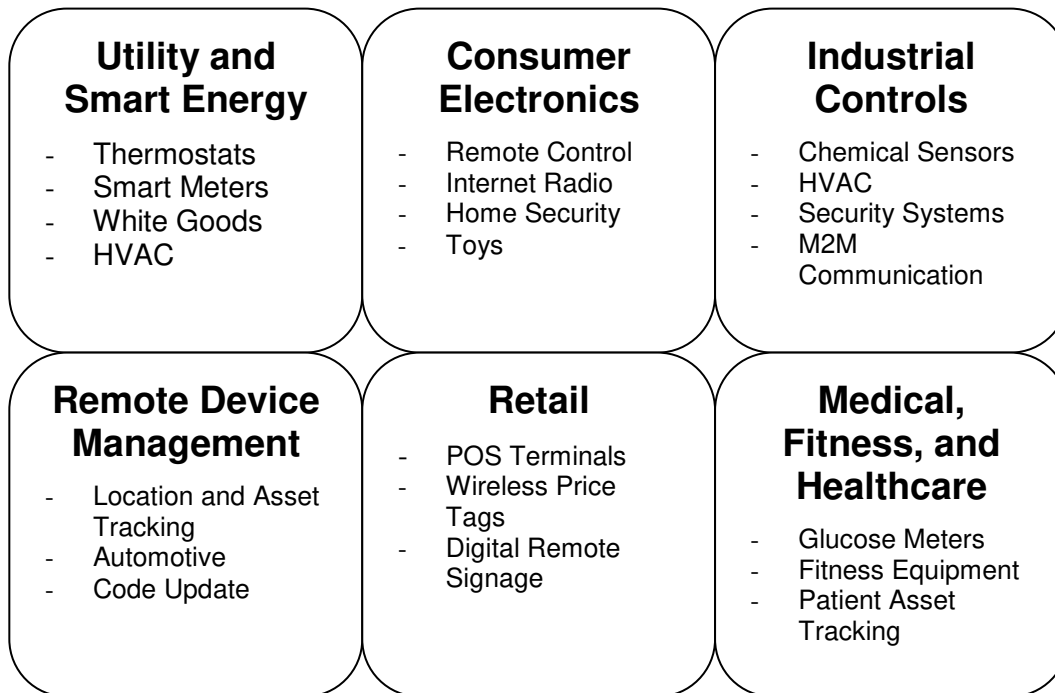

Features

- Single-chip 802.11b including MAC, baseband, RF and power amplifier
- Data Rate: 1 & 2 Mbps
- 802.11b/g/n compatible
- Low power operation
- API for embedded markets, no OS required
- PCB or external antenna options
- Hardware support for AES and RC4 based ciphers (WEP, WPA, WPA2 security)
- SPI slave interface with interrupt
- Single 3.3V supply, operates from 2.7V to 3.6V (see section 5)
- 21mm x 31mm 36-pin Dual Flat pack PCB SM Package
- Wi-Fi Certified, RoHS and CE compliant
- FCC Certified (USA, FCC ID: W7O-ZG2100-ZG2101)
- IC Certified (IC: 8248A-G21ZEROG)
- Fully compliant with EU & meets the R&TTE Directive for Radio Spectrum
- Radio Type Approval Certified (Japan, ZG2100M based solution ID: AC164136-2 – 005WWCA0311 005GZCA0149)

ZG2100M/ZG2101M

Description

The ZG2100M & ZG2101M modules are low-power 802.11b implementations. All RF components, the baseband and the entirety of the 802.11 MAC reside on-module, creating a simple and cost-effective means to add Wi-Fi connectivity for embedded devices. The module(s) implement a high-level API, simplifying design implementation and allowing the ZG2100M or ZG2101M to be integrated with 8- and 16-bit host microcontrollers. Hardware accelerators support the latest Wi-Fi security standards.

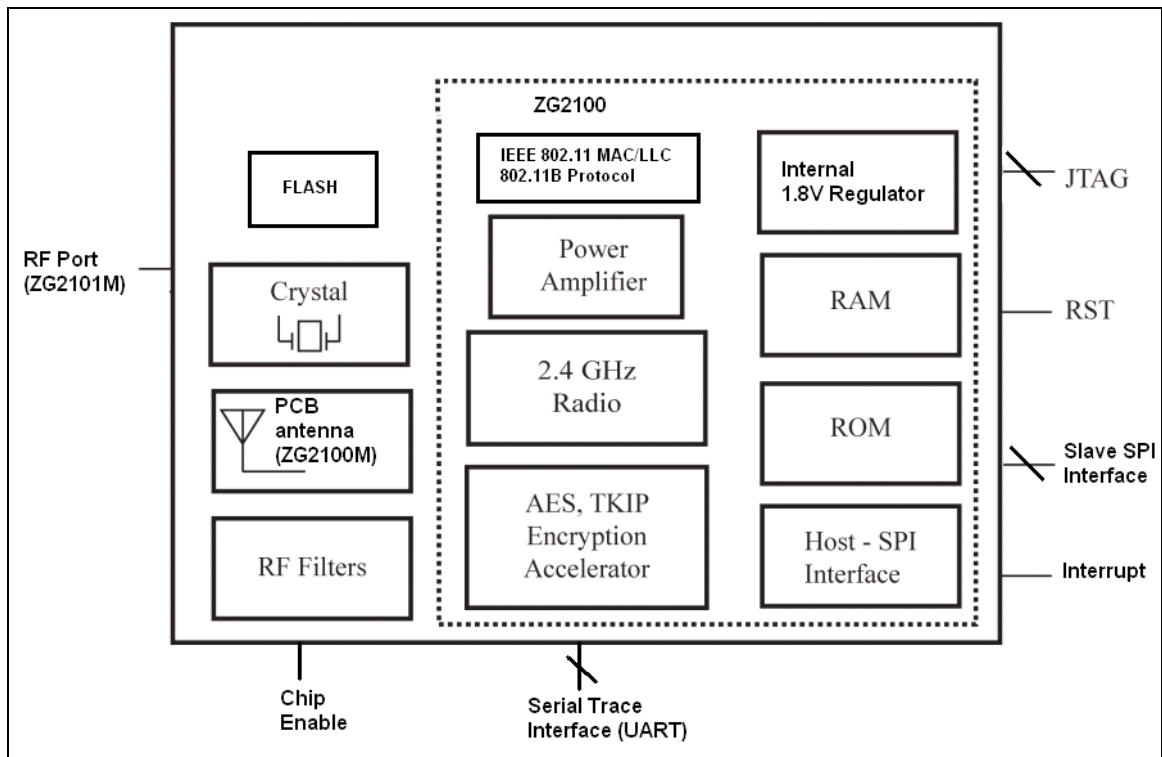

Figure 1: ZG2100M/ZG2101M Module: Functional Block Diagram

Table of Contents

1.	1. Key Features	6
2.	Detailed Description	7
	2.1 Overview	7
	2.2 Supply Blocks and Boot-Up Sequence for Single 3.3V Supply.....	7
	2.3 ZG2100 Power States	9
	2.4 Electrostatic discharge (ESD).....	10
	2.5 JTAG Interface.....	10
	2.6 Serial Interface for Trace	10
	2.7 SPI Interface	10
	2.7.1 SPI Slave Interface with Interrupt for Host Operation	10
	2.7.2 Host-Control SPI Interface.....	10
	2.7.3 SPI Timing Characteristics	11
	2.7.4 SPI Timing	12
	2.7.5 SPI Register Access.....	13
	2.8 FIFO Interface.....	14
	2.8.1 FIFO Read	14
	2.8.2 FIFO Write	15
	2.9 Fully-Integrated Radio	15
	2.10 Internal ROM/RAM/NVM	15
	2.11 Hardware Support for AES and TKIP	15
3.	ZG2100M/ZG2101M Pin-Out and Function	16
4.	Package Information.....	18
	4.1 Module Drawing.....	18
	4.2 Module Layout Guidelines	20
	4.3 Module Use Schematic.....	21
5.	Electrical Characteristics	23
	5.1 Power Consumption	23
6.	Radio Characteristics	25
	6.1 Transmitter 2.4GHz Band.....	25
	6.2 Receiver 2.4GHz Band.....	25
7.	Digital Electrical Characteristics	26
8.	Module Reflow Profile.....	27
9.	Ordering Information.....	28
10.	Regulatory Notes	29
11.	Revision History.....	31

1 Key Features

Ease of Software Development

- Simple API suited for embedded market
- Targeted for low resource host processors
- Entire MAC integrated on-chip
- Serialized MAC address, each device comes with an unique MAC address in range 001EC0xxxxxx
- Simple usage model, no requirement for OS

Low Power Operation

- Low power, 250uA sleep mode with fast wake up, 0.1uA hibernate,
- Sleep power state managed by ZG2100, enabling low average power while maintaining AP association without host control
- Battery operable from 2.7v to 3.6v (see power specs for limitations)

RF

- Integrated PA
- Support for external PA for high RF output power applications
- Power output +10dBm typical at antenna
- Power output programmable from +0dBm to meet varying application needs
- Min RX sens.of-91dBm @ 1MB/Sec. at antenna
- Integrated PCB antenna (ZG2100M)
- Support for external antenna available (ZG2101M)

Low External Component Count

- Fully integrated RF frequency synthesizer, reference clock, and Integrated PA
- Single 3.3V supply

Wi-Fi & Regulatory

- Supports 1Mbps & 2Mbps and module-based solutions are “Wi-Fi certified” for 802.11b
- Hardware support for AES, and RC4 based ciphers (WEP, WPA, WPA2 security)
- FCC Certified (USA, FCC ID: W7O-ZG2100-ZG2101), IC Certified (IC: 8248A-G21ZEROG), Radio Type Approval Certified (Japan, ZG2100M based solution ID: AC164136-2 – 005WWCA0311 005GZCA0149, Wi-Fi Certified, RoHS and CE compliant, and fully compliant with European Market and meet the R&TTE Directive for Radio Spectrum

2. Detailed Description

2.1 Overview

The ZG2100 single-chip 802.11b transceiver includes MAC, baseband, RF and power amplifier, and built in hardware support for AES, and TKIP (WEP, WPA, WPA2 security). The device has an API targeted for embedded markets so an operating system is not required for operation. There is a fully integrated radio ideal for 1 & 2Mbps operation with optional support for external PA and antenna switch operation.

The ZG2100M modules incorporate the ZeroG ZG2100 single chip 802.11b transceiver with all associated RF components, crystal oscillator, and bypass and bias passives along with a printed antenna to provide a fully integrated Wi-Fi I/O solution controllable from an 8 or 16-bit processor. The ZG2101M module is similar but bypasses the on-board PCB antenna and uses a U.FL connector for connection to an external antenna.

Interface is via SPI slave interface with interrupt for HOST operation. The modules support RS232 serial interfaces (requires level shifter) for debug and JTAG boundary scan. Operation is via a single 3.3V supply, supporting various power states, such as hibernate and SLEEP, for end applications long battery life. ZG2100M contains a built in PCB antenna for ease of system integration and significant BOM reduction.

The module is manufactured on an FR4 PCB substrate, with components on the top surface only. Connection is made as a surface mount component via flat pack (no pin) connections on two sides.

2.2 Supply Blocks and Boot-Up Sequence for Single 3.3V Supply

The internal regulators for the digital and analog core power supplies are enabled by keeping the chip enable pin (CE_N) low. The waveforms for the core supplies, illustrated on the following page, as shown when powering up the ZG2100M/ZG2101M with a nominal 3.3V applied to VDD_3.3. There is an internal power-on-reset detect which starts the boot sequence from the internal ROM when the core supply (VDD_1.8) is up. After approximately 50 ms from when VDD_3.3 supply is within specification, the ZG2100M/ZG2101M is ready for operation.

ZG2100M/ZG2101M

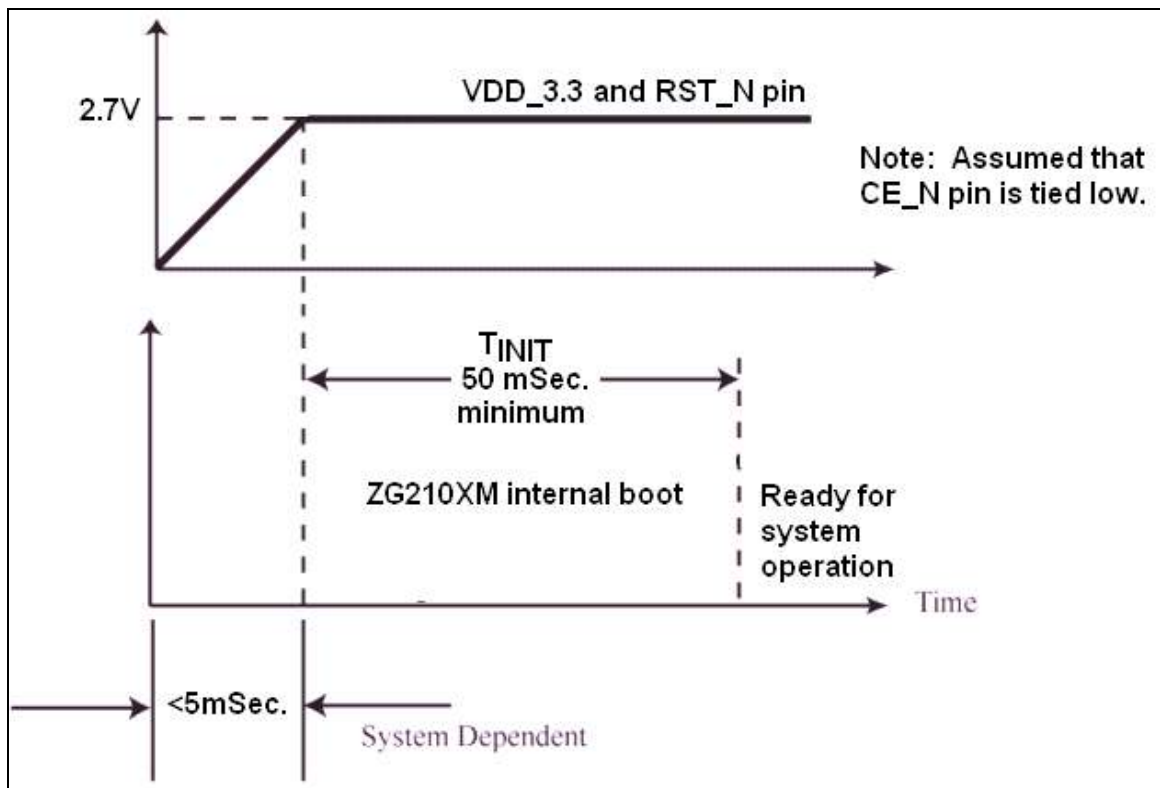

Figure 2: ZG2100M/ZG2101M Boot Sequence Timing.
Refer to Section 4.1 Electrical Characteristics, Note 1.

2.3 ZG2100 Power States

The power state definitions are as follows:

	VDD_3.3	CE_N	Circuitry
OFF	0V	0V	Power disconnected to ZG2100
HIBERNATE	3.3V	3.3V	All internal circuitries are OFF
SLEEP	3.3V	0V	Reference clock and internal bias circuitry are ON
RX ON	3.3V	0V	Receive circuits are ON
TX ON	3.3V	0V	Transmit circuits are ON
STANDBY			Transition State Only

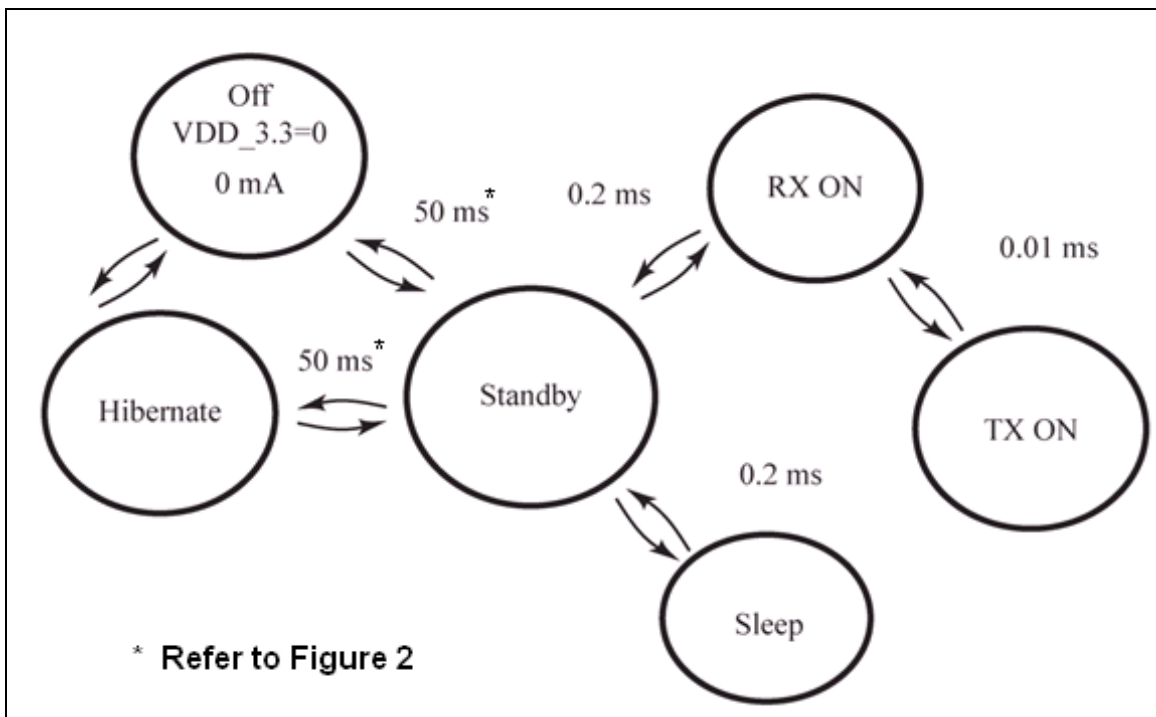

Figure 3: ZG2100M/ZG2101M Power State Diagram

2.4 Electrostatic discharge (ESD)

The ZG2100 IC, integrated within the ZG2100M/ZG2101M, has passed ESD HBM JEDEC Standard No. 22-A114 / 2000 Volts and ESD CDM JEDEC Standard No. 22-C101 / 500V all pins. Users must exercise ESD handling precautions when working with the product either in component form, or exposed PCBs.

2.5 JTAG Interface

Joint Test Action Group (JTAG) is the common name used for the IEEE 1149.1 standard entitled Standard Test Access Port and Boundary-Scan Architecture for test access ports used for testing printed circuit boards using boundary scan. ZG2100M/ZG2101M supports JTAG boundary scan. JTAG_EN and JTAG_RST_N need to be driven HIGH to enable JTAG mode.

2.6 Serial Interface for Trace

ZG2100M/ZG2101M incorporates Transmitted Data pin (UART0_TX) and Received Data pin (UART0_RX) for serial testing purposes. These pins can be connected to commercially available RS-232 line drivers/ receivers with appropriate external level shifters. The ZG2100 serial interface is fully tested at 115200 bits/seconds baud rate with RS232/UART interface applications.

2.7 SPI Interface

2.7.1 SPI Slave Interface with Interrupt for Host Operation

The slave Serial Peripheral Interface Bus (SPI) is used to interface with the HOST. The slave SPI interface works with ZG2100M/ZG2101M Interrupt line (INT_NX). When data is available for the HOST during operation, the INT_NX line is asserted low by ZG2100. The INT_NX line is de-asserted high, by ZG2100M/ZG2101M, after the data is transferred to the HOST SPI buffer. The SPI CLK Speed can be up to 25MHz.

2.7.2 Host-Control SPI Interface

The slave SPI interface implements the [CPOL=0; CPHA=0] and [CPOL=0; CPHA=1] modes (0 and 3) of operation. That is, data is clocked in on the first rising edge of the clock after Chip Select goes valid.

Data on the bus is required to be big endian, with most significant bit on the bus first and least significant bit going last. There are two decode regions. One for register access and one for a FIFO interface. Operation for both regions is shown below. The INT_NX signal allows interrupts to be signaled to the host device.

As an example of any 32-bit register access, suppose a write to register 0xF0_0F18 is desired:

Write to host register 0x38 with addr[31:16] (0x00f0). 24 bit transaction.
 Write to host register 0x39 with addr[15:0] (0x0F18). 24 bit transaction.
 Write to host register 0x3a with data[31:16]. 24 bit transaction.
 Write to host register 0x3b with data[15:0]. 24 bit transaction.
 Write to host register 0x37 with a byte that has the following pattern: 8 bit transaction
 [7:4] byte enables (active high for the valid bytes that you want to write in steps 3 and 4).
 [3:0] - 4'b0001 -> activate write to register

For a read of 0xF0_0D00:

Write to host register 0x38 with addr[31:16] (0x00F0). 24 bit transaction.
 Write to host register 0x39 with addr[15:0] (0x0F18). 24 bit transaction.
 Write to host register 0x37 with a byte that has the following pattern: 8 bit transaction
 [7:4] byte enables (active high for the valid bytes that you want to read in steps 1 and 2).
 [3:0] - 4'b0011 -> active read of register
 Read host register 0x3a to get data [31:24] 24 bit transaction
 Read host register 0x3b to get data [15:0] 24 bit transaction

Each of the steps above is a single SPI transaction; the chip select (CE_N) is active low during each step.

2.7.3 SPI Timing Characteristics

Characteristic	Min	Max
SPI, Data setup to falling clock	1 ns	
SPI, Data hold from falling clock	1 ns	
SPI SLAVE CLK		25 MHz
SPI MASTER CLK		25 MHz

Figure 4: ZG2100M/ZG2101M SPI Timing Characteristics

ZG2100M/ZG2101M

2.74 SPI Timing

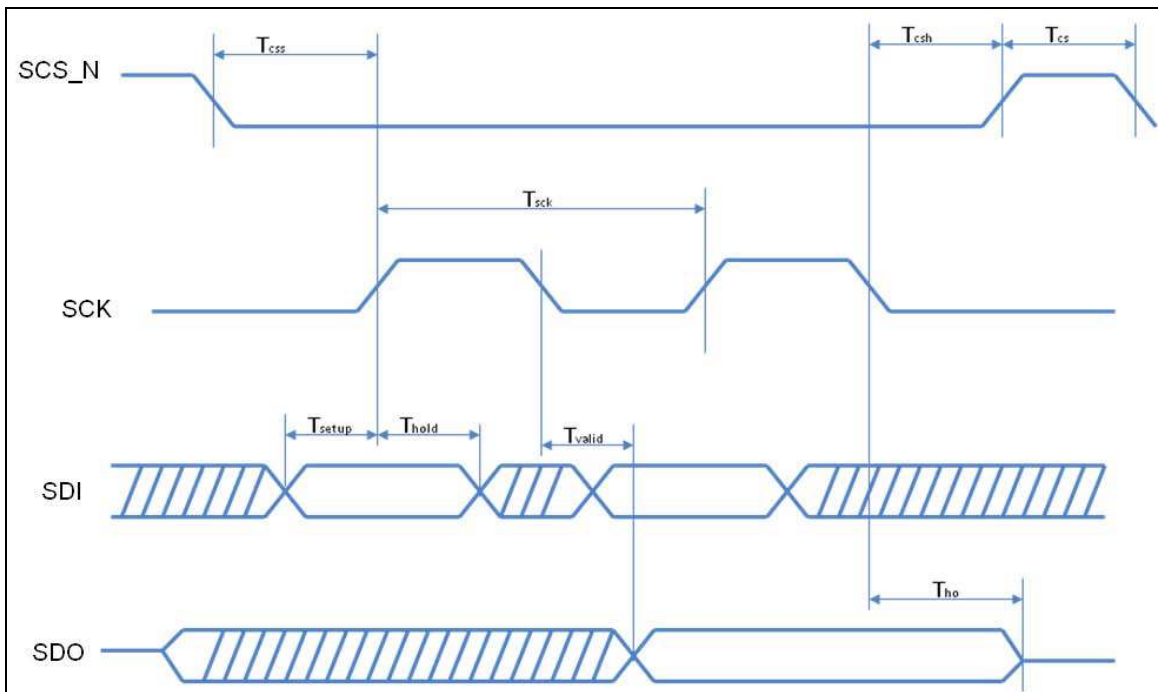

Figure 5: ZG2100M/ZG2101M SPI Timing Waveform

Symbol	Parameter	Min	Typ	Max
T_{sck}	SCK Clock Period	40 ns		
T_{cs}	SCS_N High Time	50 ns		
T_{css}	SCS_N Setup Time	50 ns		
T_{csh}	SCS_N Hold Time	50 ns		
T_{setup}	SDI Setup Time	10 ns		
T_{hold}	SDI Hold Time	10 ns		
T_{valid}	Output Valid			15 ns
T_{ho}	Output Hold Time	0		15 ns

Figure 6: ZG2100M/ZG2101M SPI Timing Data

2.7.5 SPI Register Access

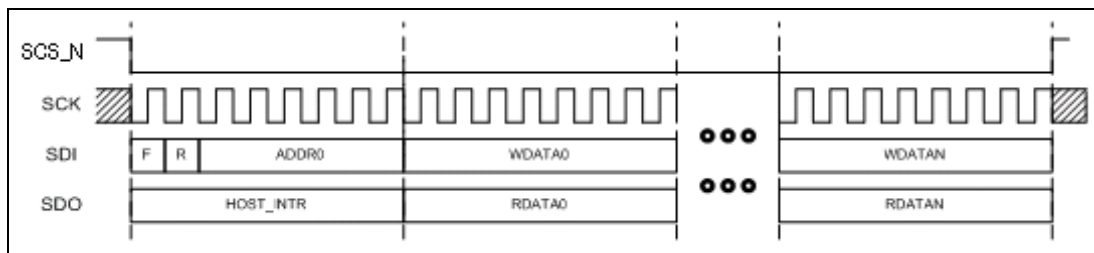

Figure 7: ZG2100M/ZG2101M SPI Register Access

F is a select between FIFO space and register space. If this bit is a 1, the data FIFO space is selected. If this bit is a 0, the register address space is selected.

R is the Read/Write bit. If this bit is a 1, the operation is a read. If this bit is a 0, the operation is a write

ADDR0 is the starting address for the transaction. This value is only used for register accesses and is ignored during FIFO accesses.

WDATAN is the write data byte. This is only used from write operations and is ignored during read operations.

RDATAn is the read data byte. This is always valid for both, read and write operations. It contains the current value of any register location.

HOST_INTR is the 8-bit interrupt register.

ZG2100M/ZG2101M

2.8 FIFO Interface

HOST FIFO Basic Commands

FCMD[2:0]

- 0x0 – RFIFO_CMD
- 0x1 – WCONT (Continue Previous Packet)
- 0x2 – WSTART0 (Start Packet, head/continue)
- 0x3 – WSTART1 (Start Packet, head0/continue)
- 0x4 – WEND CMD
- 0x5 – REND CMD

2.8.1 FIFO Read

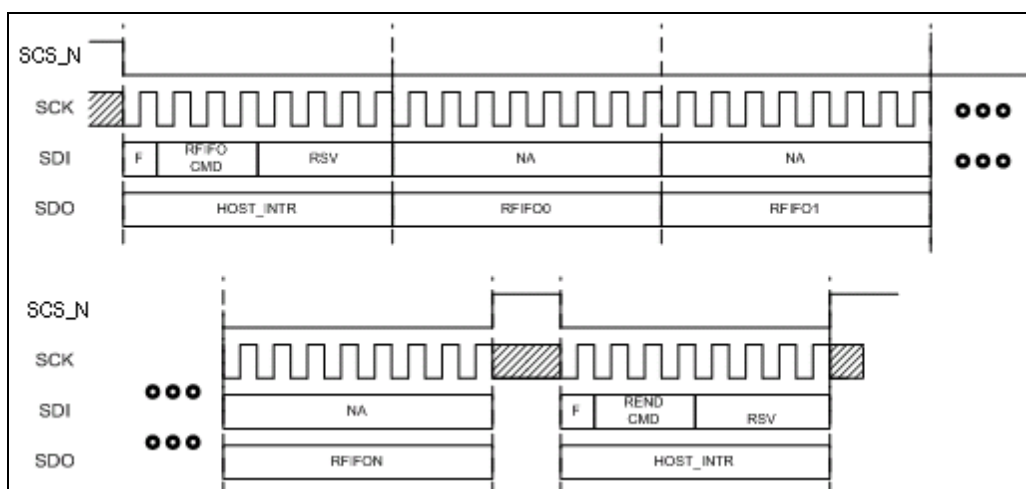

Figure 8: ZG2100M/ZG2101M FIFO Read Timing

2.8.2 FIFO Write

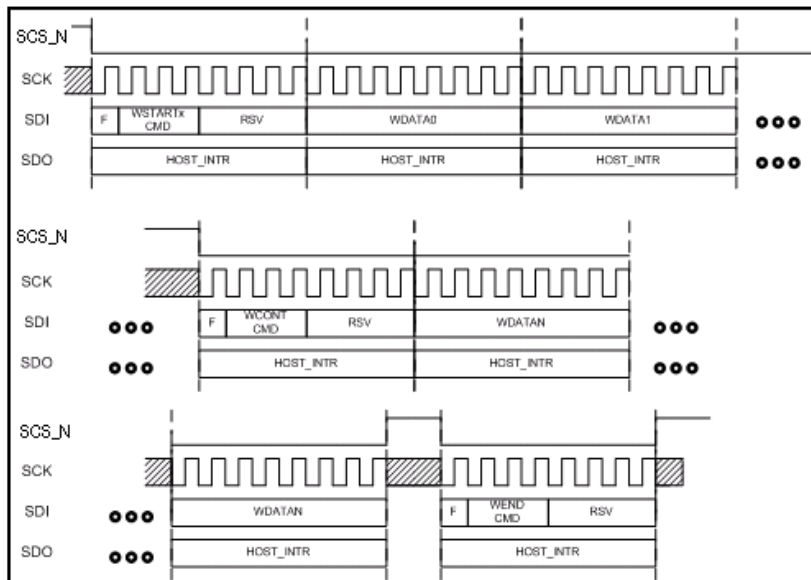

Figure 9: ZG2100M/ZG2101M FIFO Write Timing

2.9 Fully-Integrated Radio

ZG2100M/ZG2101M incorporates a fully integrated radio ideal for 1 & 2 Mbps operation with optional support for external PA operation. The direct conversion TX design incorporates an integrated PA, with up to +10dBm typical at antenna, and fully integrated internal power control loop. The direct conversion RX chain utilizes Automatic Gain Control that allows ZG2100M/ZG2101M to receive with a minimum input Level sensitivity (1Mbps @ <8% PER) of -91 dBm typical at the antenna. The ZG2100M/ZG2101M only needs an external crystal for a reference clock.

2.10 Internal ROM/RAM/NVM

ZG2100M/ZG2101M incorporates internal ROM, RAM, and NVM. The internal ROM and RAM are reserved only for ZG2100M/ZG2101M operations. The NVM holds information such as the MAC address, TX manufacturing calibration values, and frequency calibration values.

2.11 Hardware Support for AES and TKIP

ZG2100M/ZG2101M supports Wi-Fi encryption methodology (AES and RC4 based ciphers).

3. ZG2100M/ZG2101M Pin-Out and Function

Pins	Name	Internal Bias	Required Bias Resistor	Description
1	GND			Ground
2	VDD_1.8			See below
3	JTAG_TDO	H		JTAG data out
4	JTAG_TCK		Constant drive	JTAG Clock in
5	JTAG_TMS	H		JTAG Mode in
6	JTAG_TDI	H		JTAG data in
7	RST_N		Constant drive	Chip reset in
8	DNC			Do Not Connect
9	JTAG_RST_N		Constant drive	JTAG Reset in, pulling this pin low will keep JTAG idle (reset)
10	GND			Ground
11	VDD_1.8			See below
12	DNC			Do Not Connect
13	DNC			Do Not Connect
14	DNC			Do Not Connect
15	DNC			Do Not Connect
16	RES		Pull-down	FLASH Write Protect. See below.
17	VDD_3.3			3.3V Power
18	GND			Ground
19	GND			Ground
20	CE_N			Chip enable in
21	JTAG_EN	L		JTAG Enable in, this pin needs to be high for Boundary Scan use
22	DNC			Do Not Connect
23	SCS_N		Constant drive	Serial chip select from host (input)
24	VDD_1.8			See below
25	GND			Ground
26	UART_RX	H		Debug Serial in
27	UART_TX			Debug Serial out
28	GND			Ground
29	VDD_3.3			3.3V Power
30	GND			Ground
31	VDD_1.8			See below
32	SDO			Serial data out to host
33	INT_NX		Pull-up	Interrupt to host (output)
34	SCK		Constant drive	Serial clock in from host
35	SDI		Constant drive	Serial data in from host
36	GND			Ground

Notes:

1. VDD_1.8 is an internally used supply rail. **DO NOT USE** these pins to drive other components.
2. Signals that note “Constant drive” must either be constantly driven by the host, or have a pullup or pulldown in case the host is likely to tri-state the signal during power down modes. The constant drive is used to ensure defined operation of the part and to minimize leakage current during low power modes.
3. RES is used as write-protect for the internal module SPI Flash. For production use, this pin should be pulled low. Host control will enable in-field FLASH updates.

4. Package Information

4.1 Module Drawing

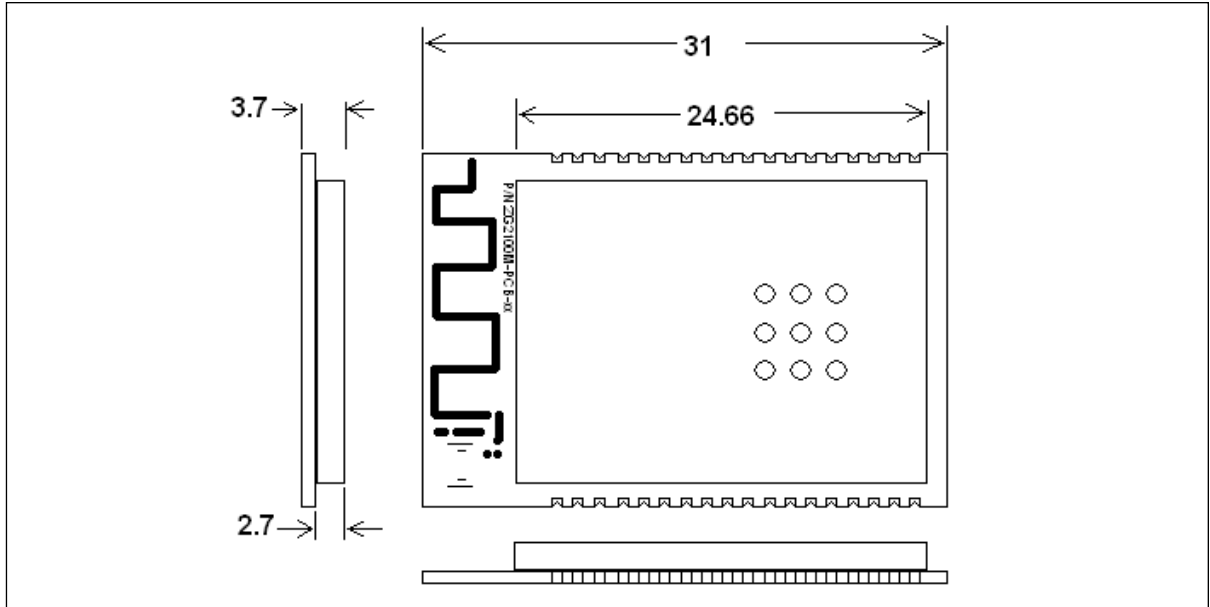

Figure 10: ZG2100M Module Physical Dimensions

All measurements are in millimeters. Tolerances for measures 0-10 mm is +/- 0.05 mm.

Tolerances for measures 10-50 mm is +/- 0.1 mm

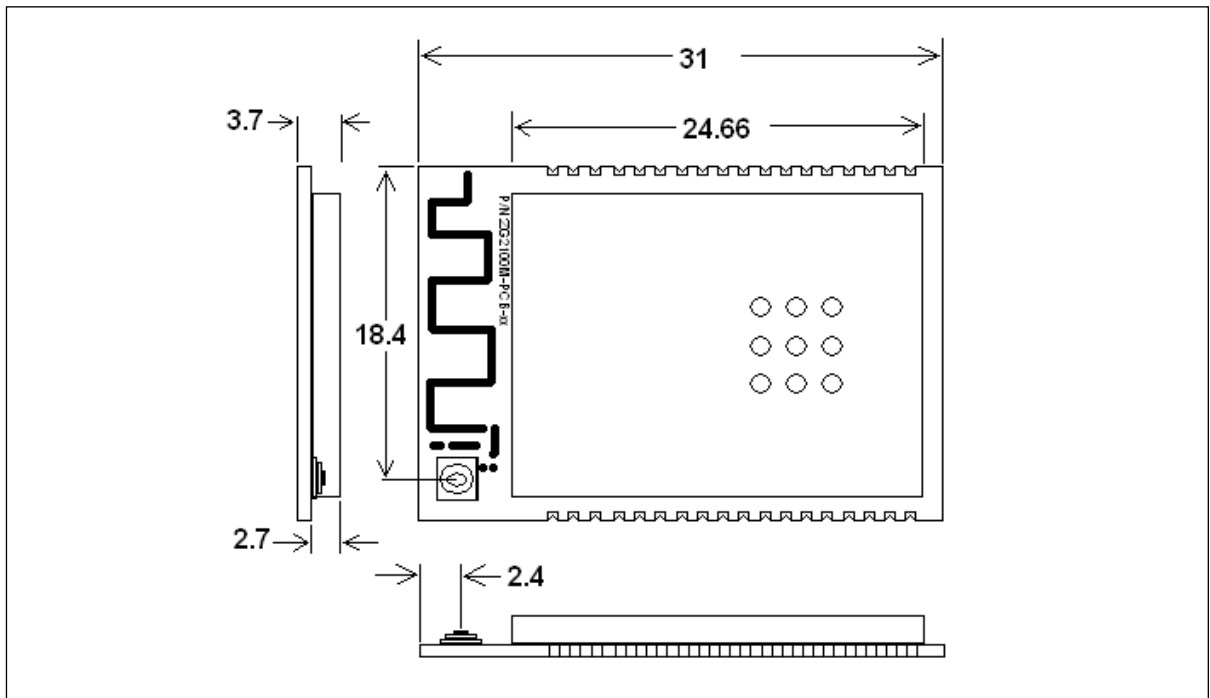

Figure 11: ZG2101M Module Physical Dimensions

All measurements are in millimeters. Tolerances for measures 0-10 mm is +/- 0.05 mm.

Tolerances for measures 10-50 mm is +/- 0.1 mm

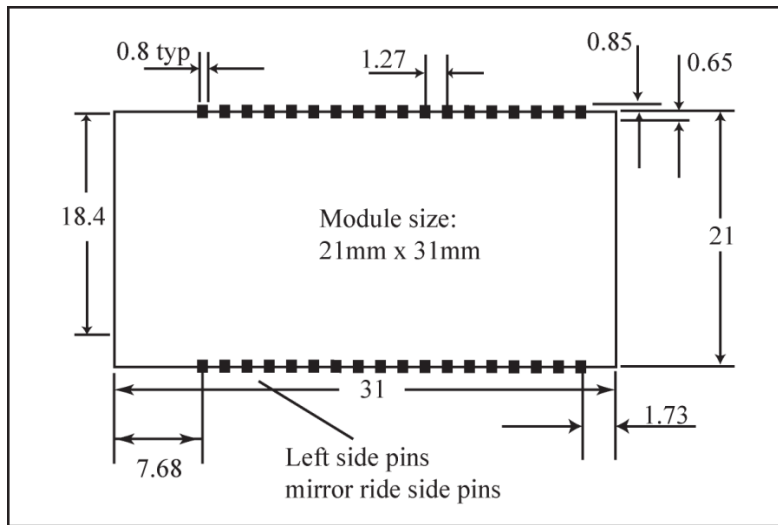

Figure 12: ZG2100M/ZG2101M Module Layout Pad Dimensions

4.2 Module Layout Guidelines

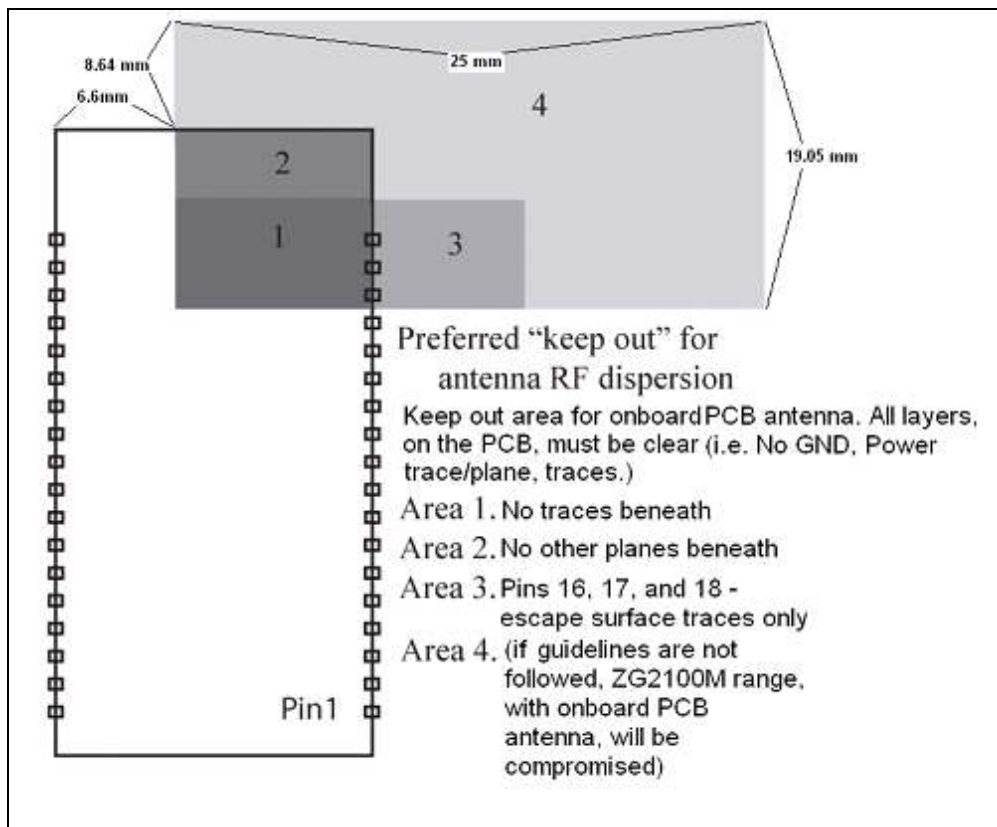

Figure 13: ZG2100M “Keep Out” Areas.

In addition to the guidelines in Figure 13, note the following suggestions:
ZG2100M and ZG2101M

- Bypass capacitors for VDD_3.3 should be as close as possible.
- Do not route any nets to VDD_1.8
- Do not use VDD_1.8 to source any external nets.
- Never place the antenna very close to metallic objects.
- The external antennas need a reasonable ground plane area for antenna efficiency.
- ZG2100M onboard PCB antenna specific
- Do not use a metallic or metalized plastic for the end product enclosure.
- Keep Plastic enclosure 1cm min height above the ZG2100M PCB antenna while maintaining the keep-out area, as shown in Figure 13.

4.3 Module Use Schematic

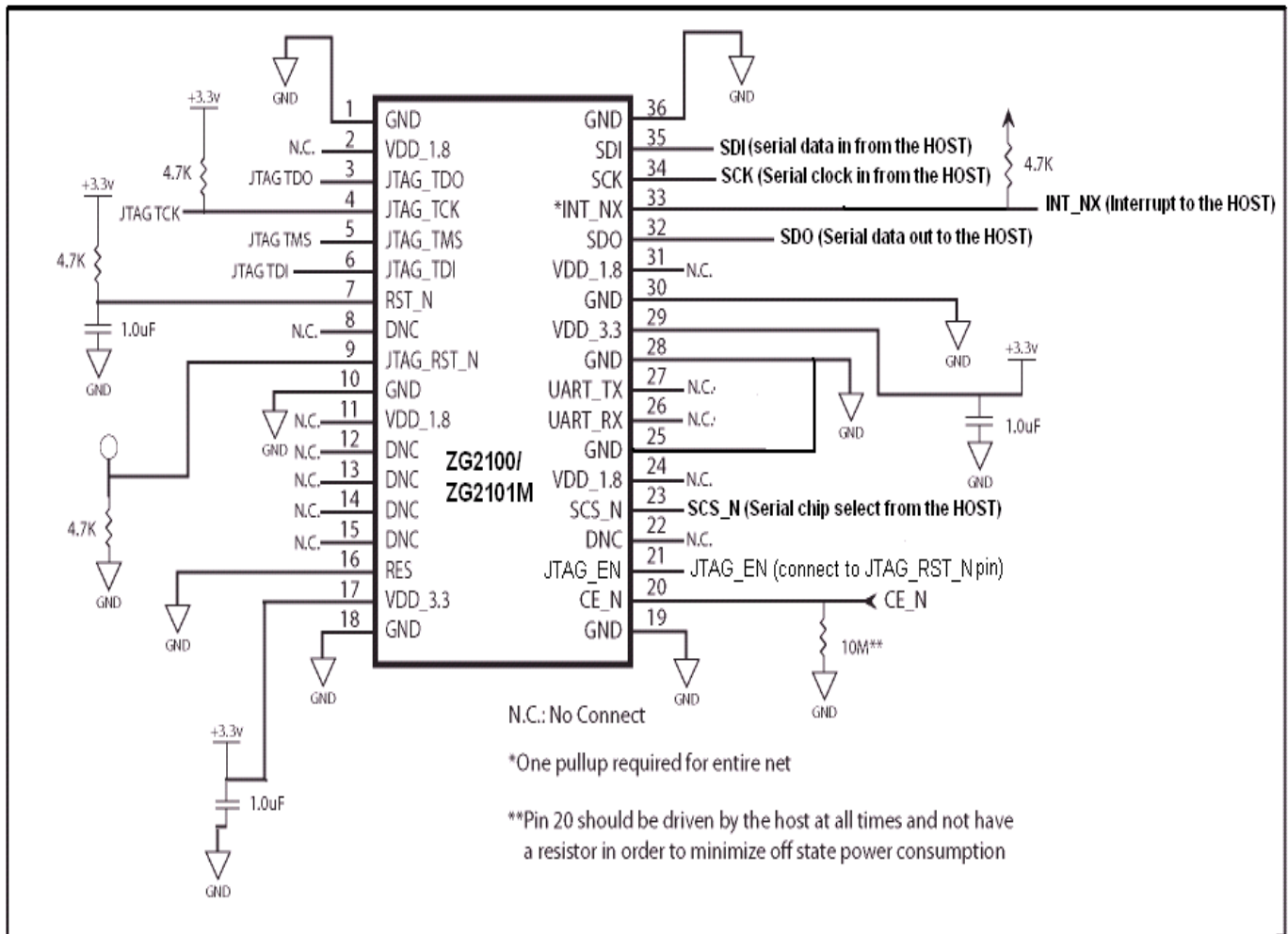

Figure 14: ZG2100M/ZG2101M Module Use Schematic.

ZG2100M/ZG2101M

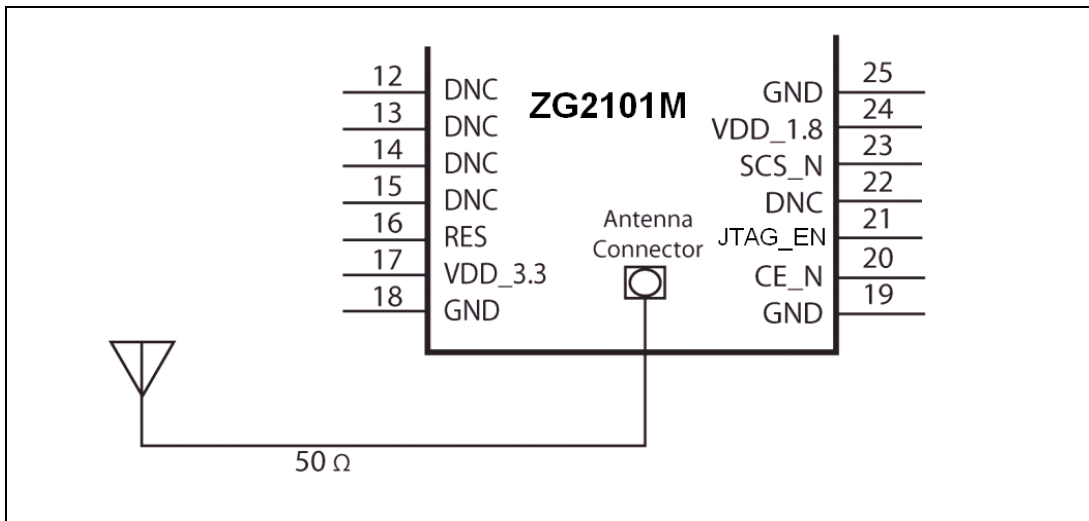

Figure 15: ZG2101M Antenna Connector/RF port diagram

Other Notes:

1. If RST_N is always driven by the HOST, the RC circuit is not needed on this pin.
2. RES is used as write-protect for the internal module SPI Flash. For production use, this pin should be pulled low. Host control will enable in-field FLASH updates.
3. It's recommended to connect UART_RX/TX (pins 26 and 27) to surface mount test points or header points, on the board, for optional connection to Hyperterminal for debugging purposes. Otherwise, they can be left as No Connects.
4. Ensure the HOST always drives the SPI port, even when not in use; otherwise, put 4.7K pull ups, to VDD_3.3, on SDI, SCK, and SCS_N.

5. Electrical Characteristics

Absolute Maximum Ratings:

Rating	Min	Max
Storage Temperature	-40C	+125C
3V supply (VDD_3.3)	0V	4.2V
VDD_3.3		0.5mSec
SDI, SCS_N, and SCK pins	-0.3 V	5.5 V

Recommended Operating Conditions:

Operating Condition	Min	Typ	Max
Ambient Temperature Range, commercial parts	0C		+70C
3V supply (VDD_3.3) – with FCC and IC cert	2.70V	3.3V	3.63V
3V supply (VDD_3.3) – for ETSI cert	2.80V	3.3V	3.63V
3V supply (VDD_3.3) – for Japan cert	2.97V	3.3V	3.63V

5.1 Power Consumption

Nominal conditions: 25C, VDD_3.3=3.3V

Power Conservation Modes	Min	Typ	Max	Unit
Hibernate, CE_N=3.3v		0.1		uA
Sleep		250		uA
Standby (transitional power state)		10		mA
Core Supply	Min	Typ	Max	Unit
Rx On, Receive I _{rx} @ -83dBm with 2Mb/Sec. modulated signal input power at antenna port		85		mA
Tx On, Transmit I _{tx} , +0dBm		115		mA
Tx On, Transmit I _{tx} , +10dBm		154		mA

Electrical Characteristics Notes:

1. If VDD_3.3V supply takes longer than Maximum ramp up time, then CE_N or RST_N (held in active states; CE_N=3.3V or RST_N=0V) must be used to delay module boot up until VDD_3.3 is within operating conditions range.
2. For Rx On, RX chain is fully ON.

ZG2100M/ZG2101M

3. For Tx On, Pout= 0dBm (measured at antenna); 2Mb/Sec. modulated signal
4. For Tx On, Pout= +10dBm (measured at antenna); 2Mb/Sec. modulated signal
5. 3.3V Current Consumption values represent Typical Peak currents, and the measured currents conditions were done with 85% duty cycle modulated signal. WiFi applications typically operate in less than 85% TX duty cycle. Tx is dependent on such criteria as transmit power setting, and transmit data rate and bandwidth being used. Rx is affected by connectivity distance.
6. All characteristics in this specification are for commercial temperature rated parts only.
7. Operation in EU and/or Japan over extended voltage range of 2.7V to 3.6V will require additional certification testing by customer. The module is capable of this operation.
8. While 3.63V is the maximum operating voltage, the module will detect an overvoltage condition at 4.2V and disable the RF Transmit function. This is an RF Certification behavior pertaining to disabling transmission in unforeseen overvoltage conditions.
9. Listed Absolute Maximum Ratings are not meant for functional operation. Operation at these levels is not guaranteed, and may reduce the operating life of the component.

6. Radio Characteristics

Nominal conditions: 25C, VDD_3.3=3.3V

Frequency range	Min	Max	Unit
F_LO	2412	2484	MHz

6.1 Transmitter 2.4 GHz Band

Nominal conditions: 25C, VDD_3.3 =3.3V, Flo=2437MHz; 2Mb/Sec. modulated signal duty cycled at 95% measured at recommended single ended balun output (see Figure 8).

TX	Min	Typ	Max	Unit
Average Pout (Transmit spectrum mask Compliant)		+10		dBm
Average Pout gain step resolution from +5 to +10 dBm		0.5		dB
Average Pout gain step resolution from -5 to +5 dBm		1.0		dB
Average Pout settled variation	-0.5		0.5	dB

6.2 Receiver 2.4 GHz Band

Nominal conditions: 25C, VDD_3.3 =3.3V, Flo=2437MHz; measured at recommended single ended balun input (see Figure 8).

RX	Min	Typ	Max	Unit
RX Min Input Level Sensitivity, 1Mbps, 8% PER		-91		dBm
RX Min Input Level Sensitivity, 2Mbps, 8% PER		-88		dBm
RX Max Input Level (Power), 1Mbps, 8% PER		-4		dBm
RX Max Input Level (Power), 2Mbps,8% PER		-4		dBm

7. Digital Electrical Characteristics

Nominal conditions: 25C, VDD_3.3=3.3V

Characteristic	Min	Typ	Max	Unit
VIL (Input Low Voltage)	-0.3		0.8	V
VIH (Input High Voltage)	2		5.5	V
VOL (Output Low Voltage)			0.4	V
VOH (Output High Voltage)	2.4			V
IOL (Low Level Output Current @ VOL Max)		8.5		mA
IOH (High Level Output Current @ VOH Min)		15.4		mA

8. Module Reflow Profile

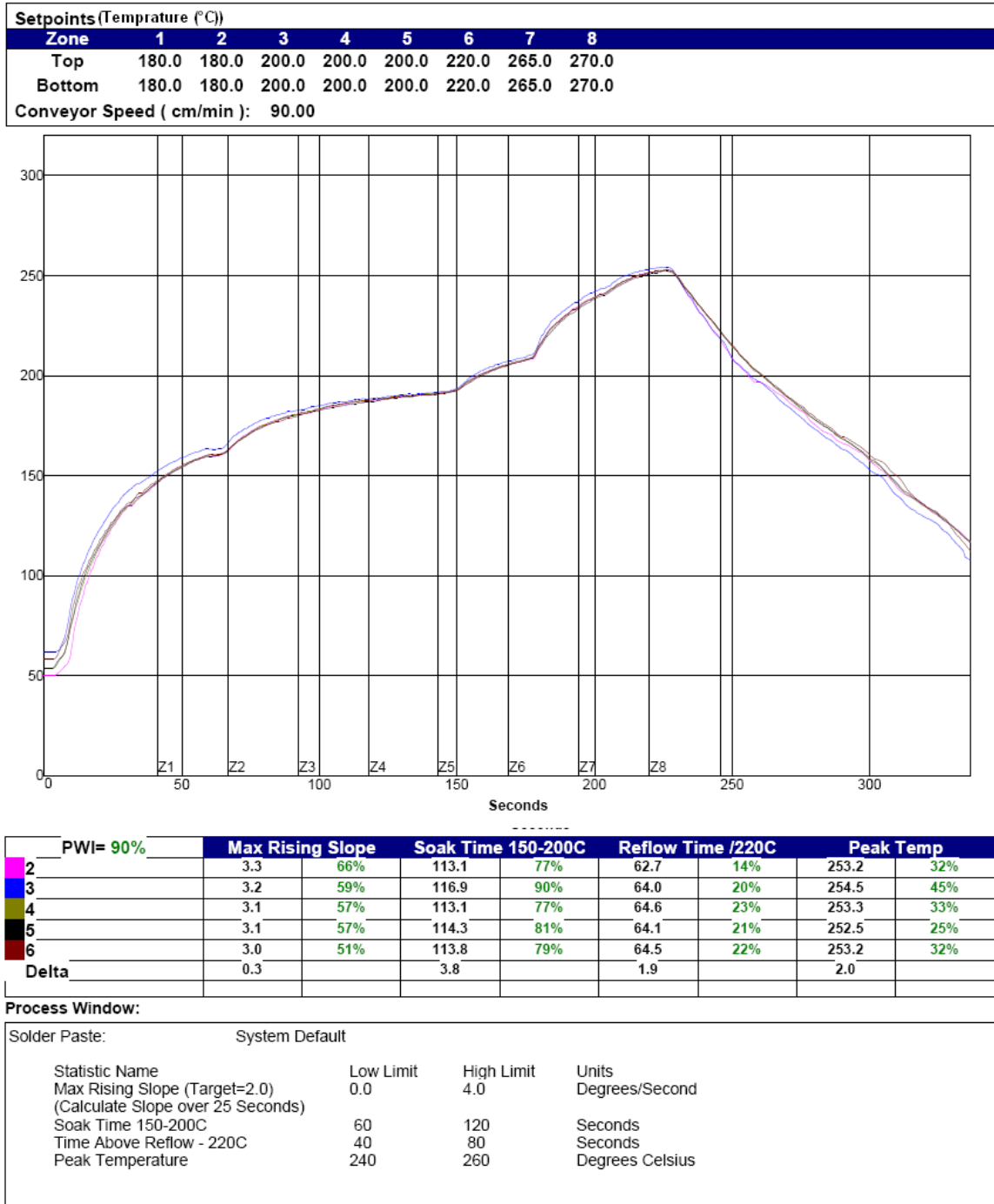

Figure 16: ZG2100M/ZG2101M Module Reflow Setpoints

9. Ordering Information

Device Description	Comment	Ordering Number
Module	Commercial grade with PCB antenna	ZG2100MC
Module	Commercial grade for use with an external antenna	ZG2101MC

10. Regulatory Notes

Federal Communication Commission Interference Statement

This equipment has been tested and found to comply with the limits for a Class B digital device, pursuant to Part 15 of the FCC Rules. These limits are designed to provide reasonable protection against harmful interference in a residential installation. This equipment generates uses and can radiate radio frequency energy and, if not installed and used in accordance with the instructions, may cause harmful interference to radio communications. However, there is no guarantee that interference will not occur in a particular installation. If this equipment does cause harmful interference to radio or television reception, which can be determined by turning the equipment off and on, the user is encouraged to try to correct the interference by one of the following measures:

- Reorient or relocate the receiving antenna.
- Increase the separation between the equipment and receiver.
- Connect the equipment into an outlet on a circuit different from that to which the receiver is connected.
- Consult the dealer or an experienced radio/TV technician for help.

FCC Caution: To assure continued compliance, (example – use only shielded interface cables when connecting to computer or peripheral devices). Any changes or modifications not expressly approved by the party responsible for compliance could void the user's authority to operate this equipment.

This device complies with Part 15 of the FCC Rules. Operation is subject to the following two conditions: (1) This device may not cause harmful interference, and (2) this device must accept any interference received, including interference that may cause undesired operation.

IMPORTANT NOTE:

FCC & IC Radiation Exposure Statement:

This equipment complies with FCC & IC radiation exposure limits set forth for an uncontrolled environment. This equipment should be installed and operated with minimum distance 20cm between the radiator & your body.

This transmitter must not be co-located or operating in conjunction with any other antenna or transmitter. This device is intended only for OEM integrators under the following conditions:

- 1) The antenna must be installed such that 20 cm is maintained between the antenna and users, and
- 2) The transmitter module may not be co-located with any other transmitter or antenna.

As long as 2 conditions above are met, further transmitter test will not be required. However, the OEM integrator is still responsible for testing their end-product for any additional compliance requirements required with this module installed (for example, digital device emissions, PC peripheral requirements, etc.).

IMPORTANT NOTE: In the event that these conditions cannot be met (for example certain laptop configurations or co-location with another transmitter), then the FCC & IC authorizations are no longer considered valid and the FCC & IC IDs cannot be used on the final product. In these circumstances, the OEM integrator will be responsible for re-evaluating the end product (including the transmitter) and obtaining separate FCC & IC authorizations.

ZG2100M/ZG2101M

End Product Labeling

This transmitter module is authorized only for use in device where the antenna may be installed such that 20 cm may be maintained between the antenna and users (for example access points, routers, wireless ADSL modems, and similar equipment). The final end product must be labeled in a visible area with the following: “Contains FCCID: W7OZG2100-ZG2101 & IC: 8248A-G21ZEROG”.

IC Certification — Canada

The labeling requirements for Industry Canada are similar to those of the FCC. A visible label on the outside of the final product must display the IC labeling. The user is responsible for the end product to comply with IC ICES-003 (Unintentional radiators)

Manual Information That Must be Included

The user’s manual for end users must include the following in-information in a prominent location.

IMPORTANT NOTE: To comply with FCC & IC RF exposure compliance requirements, the antenna used for this transmitter must be installed to provide a separation distance of at least 20 cm from all persons and must not be co-located or operating in conjunction with any other antenna or transmitter.

Other notes:

ZeroG modules have been built or under development for near body exposure applications. The 20cm statement is a standard note because absorption rate testing (commonly known as SAR or Specific absorption rate) is not modularly transferable for FCC/IC. Thus, if a radio is being used against the body, the end user is still responsible to test for regulatory near body exposure testing (for USA, please refer to the following):

FCC Part 1.1037

FCC Part 2.1091 Mobile Devices

FCC Part 2.1093 Portable Devices

FCC Part 15.247 (b) (4)

11. Revision History

Revision A (March 2010)

Revision A includes document updates from version 1.0 to 2.4.



WORLDWIDE SALES AND SERVICE

AMERICAS

Corporate Office
2355 West Chandler Blvd.
Chandler, AZ 85224-6199
Tel: 480-792-7200
Fax: 480-792-7277
Technical Support:
<http://support.microchip.com>
Web Address:
www.microchip.com

Atlanta
Duluth, GA
Tel: 678-957-9614
Fax: 678-957-1455

Boston
Westborough, MA
Tel: 774-760-0087
Fax: 774-760-0088

Chicago
Itasca, IL
Tel: 630-285-0071
Fax: 630-285-0075

Cleveland
Independence, OH
Tel: 216-447-0464
Fax: 216-447-0643

Dallas
Addison, TX
Tel: 972-818-7423
Fax: 972-818-2924

Detroit
Farmington Hills, MI
Tel: 248-538-2250
Fax: 248-538-2260

Kokomo
Kokomo, IN
Tel: 765-864-8360
Fax: 765-864-8387

Los Angeles
Mission Viejo, CA
Tel: 949-462-9523
Fax: 949-462-9608

Santa Clara
Santa Clara, CA
Tel: 408-961-6444
Fax: 408-961-6445

Toronto
Mississauga, Ontario, Canada
Tel: 905-673-0699
Fax: 905-673-6509

ASIA/PACIFIC

Asia Pacific Office
Suites 3707-14, 37th Floor
Tower 6, The Gateway Harbour City, Kowloon Hong Kong
Tel: 852-2401-1200
Fax: 852-2401-3431

Australia - Sydney
Tel: 61-2-9868-6733
Fax: 61-2-9868-6755

China - Beijing
Tel: 86-10-8528-2100
Fax: 86-10-8528-2104

China - Chengdu
Tel: 86-28-8665-5511
Fax: 86-28-8665-7889

China - Chongqing
Tel: 86-23-8980-9588
Fax: 86-23-8980-9500

China - Hong Kong SAR
Tel: 852-2401-1200
Fax: 852-2401-3431

China - Nanjing
Tel: 86-25-8473-2460
Fax: 86-25-8473-2470

China - Qingdao
Tel: 86-532-8502-7355
Fax: 86-532-8502-7205

China - Shanghai
Tel: 86-21-5407-5533
Fax: 86-21-5407-5066

China - Shenyang
Tel: 86-24-2334-2829
Fax: 86-24-2334-2393

China - Shenzhen
Tel: 86-755-8203-2660
Fax: 86-755-8203-1760

China - Wuhan
Tel: 86-27-5980-5300
Fax: 86-27-5980-5118

China - Xian
Tel: 86-29-8833-7252
Fax: 86-29-8833-7256

China - Xiamen
Tel: 86-592-2388138
Fax: 86-592-2388130

China - Zhuhai
Tel: 86-756-3210040
Fax: 86-756-3210049

ASIA/PACIFIC

India - Bangalore
Tel: 91-80-3090-4444
Fax: 91-80-3090-4123

India - New Delhi
Tel: 91-11-4160-8631
Fax: 91-11-4160-8632

India - Pune
Tel: 91-20-2566-1512
Fax: 91-20-2566-1513

Japan - Yokohama
Tel: 81-45-471-6166
Fax: 81-45-471-6122

Korea - Daegu
Tel: 82-53-744-4301
Fax: 82-53-744-4302

Korea - Seoul
Tel: 82-2-554-7200
Fax: 82-2-558-5932 or 82-2-558-5934

Malaysia - Kuala Lumpur
Tel: 60-3-6201-9857
Fax: 60-3-6201-9859

Malaysia - Penang
Tel: 60-4-227-8870
Fax: 60-4-227-4068

Philippines - Manila
Tel: 63-2-634-9065
Fax: 63-2-634-9069

Singapore
Tel: 65-6334-8870
Fax: 65-6334-8850

Taiwan - Hsin Chu
Tel: 886-3-6578-300
Fax: 886-3-6578-370

Taiwan - Kaohsiung
Tel: 886-7-536-4818
Fax: 886-7-536-4803

Taiwan - Taipei
Tel: 886-2-2500-6610
Fax: 886-2-2508-0102

Thailand - Bangkok
Tel: 66-2-694-1351
Fax: 66-2-694-1350

EUROPE

Austria - Wels
Tel: 43-7242-2244-39
Fax: 43-7242-2244-393

Denmark - Copenhagen
Tel: 45-4450-2828
Fax: 45-4485-2829

France - Paris
Tel: 33-1-69-53-63-20
Fax: 33-1-69-30-90-79

Germany - Munich
Tel: 49-89-627-144-0
Fax: 49-89-627-144-44

Italy - Milan
Tel: 39-0331-742611
Fax: 39-0331-466781

Netherlands - Drunen
Tel: 31-416-690399
Fax: 31-416-690340

Spain - Madrid
Tel: 34-91-708-08-90
Fax: 34-91-708-08-91

UK - Wokingham
Tel: 44-118-921-5869
Fax: 44-118-921-5820