

## **DESCRIPTION**

The AP64500Q is 5A, synchronous buck converter with a wide input voltage range of 3.8V to 40V. The device fully integrates a 45mΩ high-side power MOSFET and a 20mΩ low-side power MOSFET to provide high-efficiency step-down DC/DC conversion.

The AP64500Q device is easily used by minimizing the external component count due to its adoption of peak current mode control.

The AP64500Q design is optimized for Electromagnetic Interference (EMI) reduction. The converter features Frequency Spread Spectrum (FSS) with a

switching frequency jitter of  $\pm 6\%$ , which reduces EMI by not allowing emitted energy to stay in any one frequency for a significant period of time. It also has a proprietary gate driver scheme to resist switching node ringing without sacrificing MOSFET turn-on and turn-off times, which reduces high-frequency radiated EMI noise caused by MOSFET switching.

The device is available in a SO-8EP package.

## **FEATURES**

- Qualified for Automotive Applications
- Wide Input Range: 3.8V to 40V
- 5A Continuous Output Current
- 0.8V  $\pm 1\%$  Reference Voltage
- 25 $\mu$ A Ultralow Quiescent Current (Pulse Frequency Modulation)
- Programmable Switching Frequency: 100kHz to 2.2MHz
- External Clock Synchronization: 100kHz to 2.2MHz
- Proprietary Gate Driver Design for Best EMI Reduction
- Frequency Spread Spectrum (FSS) to Reduce EMI
- Low-Dropout (LDO) Mode
- Precision Enable Threshold to adjust UVLO
- Protection Circuitry
  - Undervoltage Lockout (UVLO)
  - Output Overvoltage Protection (OVP)
  - Cycle-by-Cycle Peak Current Limit
  - Thermal Shutdown
- Totally Lead-Free & Fully RoHS Compliant
- Halogen and Antimony Free. “Green” Device

### APPLICATIONS

- 5V, 12V, and 24V Distributed Power Bus Supplies
- White Goods and Small Home Appliances
- Home Audio
- Network Systems
- Consumer Electronics
- Cordless Power Tools
- Optical Communication and Networking Systems
- General Purpose Point of Load

### TYPICAL APPLICATIONS CIRCUIT

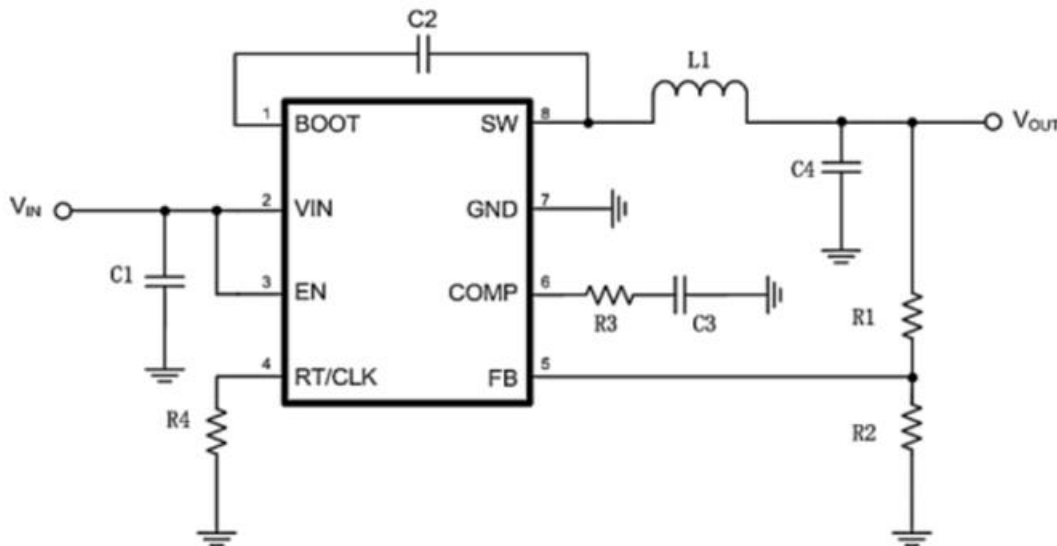

Figure 1. Typical Application Circuit

### ABSOLUTE MAXIMUM RATINGS

Symbol	Parameter	Rating	Unit
VIN	Supply Pin Voltage	-0.3 to +42.0 (DC)	V
		-0.3 to +45.0 (400ms)	
V <sub>BST</sub>	Bootstrap Pin Voltage	V <sub>SW</sub> - 0.3 to V <sub>SW</sub> + 6.0	V
V <sub>EN</sub>	Enable/UVLO Pin Voltage	-0.3 to +42.0	V
V <sub>RT/CLK</sub>	RT/CLK Pin Voltage	-0.3 to +6.0	V
V <sub>FB</sub>	Feedback Voltage	-0.3V to +6.0	V
V <sub>COMP</sub>	Compensation Pin Voltage	-0.3 to +6.0	V
V <sub>SW</sub>	Switch Node Voltage	-0.3 to VIN + 0.3 (DC)	V
		-2.5 to VIN + 2.0 (20ns)	

$T_J$	Junction Temperature	+160	°C
$T_L$	Lead Temperature	+260	°C

### RECOMMENDED OPERATING CONDITIONS

Symbol	Parameter	Min	Max	Unit
VIN	Supply Voltage	3.8	40	V
VOUT	Output Voltage	0.8	39	V
$T_A$	Operating Ambient Temperature Range	-40	+125	°C
$T_J$	Operating Junction Temperature Range	-40	+150	°C

### EVALUATION BOARD

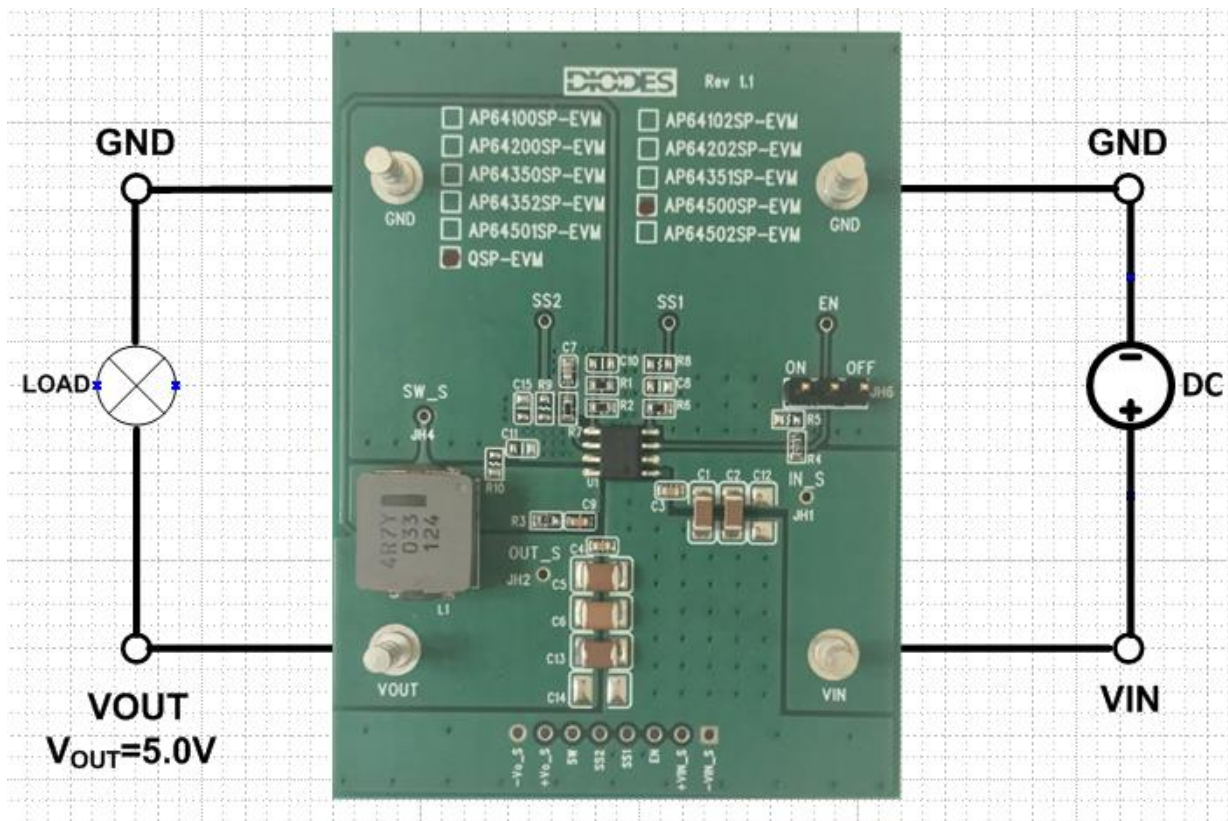

Figure 2. AP64500QSP-EVM

### QUICK START GUIDE

The AP64500QSP-EVM has a simple layout and allows access to the appropriate signals through test points. To evaluate the performance of the AP64500QSP, follow the procedure below:

1. Connect a power supply to the input terminals  $V_{IN}$  and GND. Set  $V_{IN}$  to 12V.
2. Connect the positive terminal of the electronic load to  $V_{OUT}$  and negative terminal to GND.
3. For Enable, to enable IC, place a jumper at JH6 to “ON” position to connect EN pin to  $V_{IN}$  through 100K $\Omega$  resistor or leave it OPEN. Jump to “OFF” position to disable IC.
4. The evaluation board should now power up with a 5.0V output voltage.
5. Check for the proper output voltage of 5.0V ( $\pm 1\%$ ) at the output terminals  $V_{OUT}$  and GND. Measurement can also be done with a multimeter with the positive and negative leads between  $V_{OUT}$  and GND.
6. Set the load to 5A through the electronic load. Check for the stable operation of the SW signal on the oscilloscope. Measure the switching frequency.

### MEASUREMENT/PERFORMANCE GUIDELINES:

- 1) When measuring the output voltage ripple, maintain the shortest possible ground lengths on the oscilloscope probe. Long ground leads can erroneously inject high frequency noise into the measured ripple.
- 2) For efficiency measurements, connect an ammeter in series with the input supply to measure the input current. Connect an electronic load to the output for output current.

### SETTING OUTPUT VOLTAGE:

Table 1 shows a list of recommended component selections for common output voltages.

VOUT	R1	R2	L1	R7	C7	C1, C2	C5, C6, C13
1.2V	4.99K $\Omega$	10K $\Omega$	1.5 $\mu$ H	3.74K $\Omega$	2.7nF	2x10 $\mu$ F	3x22 $\mu$ F
1.5V	8.66K $\Omega$	10K $\Omega$	2.2 $\mu$ H	4.75K $\Omega$	2.7nF	2x10 $\mu$ F	3x22 $\mu$ F
1.8V	12.4K $\Omega$	10K $\Omega$	2.2 $\mu$ H	5.62K $\Omega$	2.7nF	2x10 $\mu$ F	3x22 $\mu$ F
2.5V	21.5K $\Omega$	10K $\Omega$	3.3 $\mu$ H	7.87K $\Omega$	2.7nF	2x10 $\mu$ F	3x22 $\mu$ F
3.3V	31.6K $\Omega$	10K $\Omega$	3.3 $\mu$ H	10.5K $\Omega$	2.7nF	2x10 $\mu$ F	3x22 $\mu$ F
5.0V	52.3K $\Omega$	10K $\Omega$	4.7 $\mu$ H	15.8K $\Omega$	2.7nF	2x10 $\mu$ F	3x22 $\mu$ F
12V	140K $\Omega$	10K $\Omega$	10 $\mu$ H	37.4K $\Omega$	2.7nF	2x10 $\mu$ F	3x22 $\mu$ F

**Table 1. Common Output Voltages**

**EVALUATION BOARD SCHEMATIC**

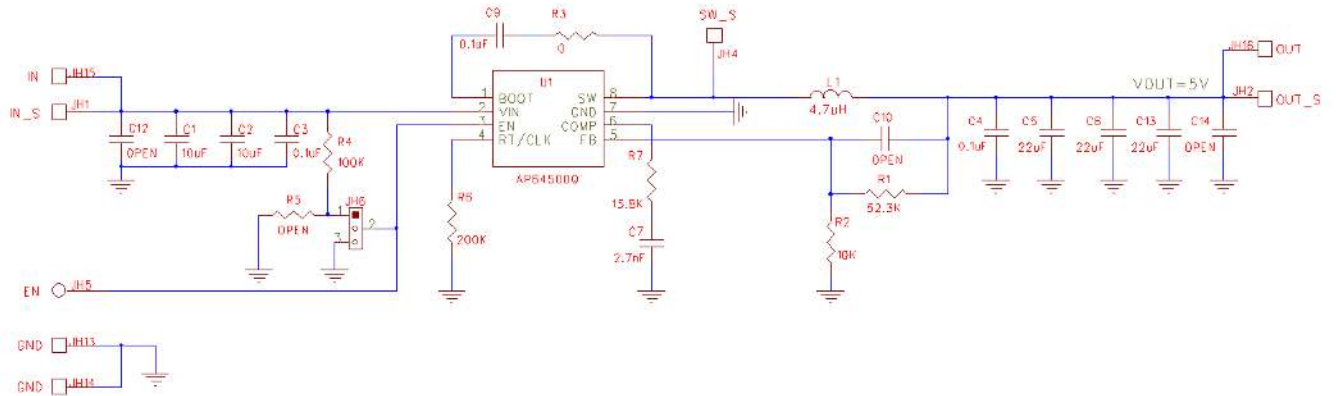

**Figure 3. AP64500QSP-EVM Schematic**

**PCB TOP LAYOUT**

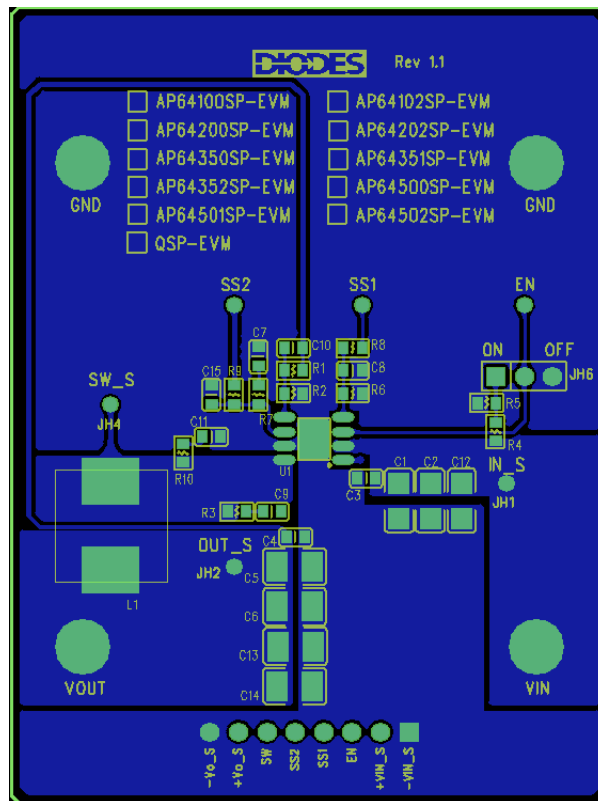

**Figure 4. AP64500QSP-EVM – Top Layer**

## PCB BOTTOM LAYOUT

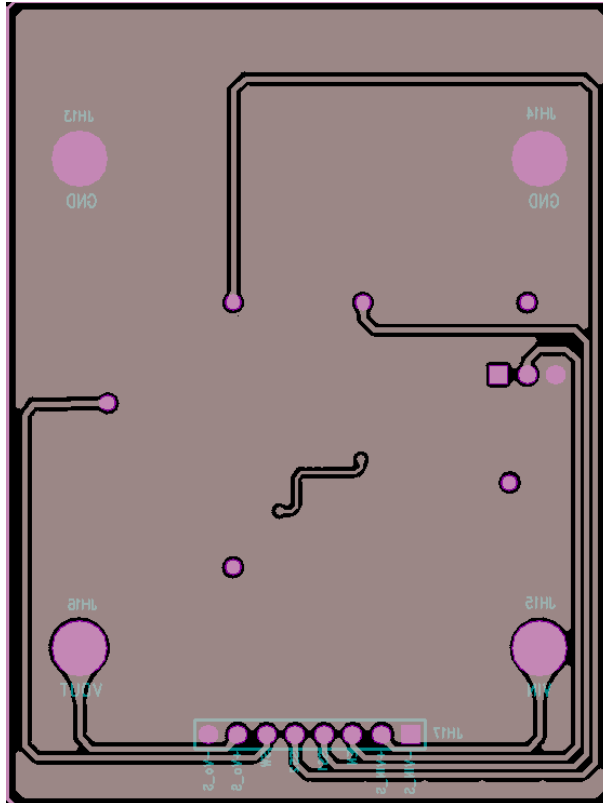

Figure 5. AP64500QSP-EVM – Bottom Layer

### AUTOMOTIVE BILL OF MATERIALS for AP64500QSP-EVM @V<sub>OUT</sub>=5V

Ref	Value	Description	Qty	Size	Vendor Name	Manufacturer PN
C1, C2	10 $\mu$ F	Ceramic Capacitor, 50V	2	1206	TDK	CGA5L1X7R1H106K160AC
C3, C4, C9	0.1 $\mu$ F	Ceramic Capacitor, 50V	3	0603	TDK	CGA3E3X8R1H104K080AB
C5, C6, C13	22 $\mu$ F	Ceramic Capacitor, 16V	3	1210	TDK	CGA6P1X8L1C226M250AC
C7	2.7nF	Ceramic Capacitor, 50V	1	0603	TDK	CGA3E2NP01H272J080AA
R1	52.3K $\Omega$	RES SMD	1	0603	Panasonic	ERJ-3EKF5232V
R2	10K $\Omega$	RES SMD	1	0603	Panasonic	ERJ-3EKF1002V
R3	0 $\Omega$	RES SMD	1	0603	Panasonic	ERJ-3GEY0R00V
R4	100K $\Omega$	RES SMD	1	0603	Panasonic	ERJ-3RBD104V
R6	200K $\Omega$	RES SMD	1	0603	Panasonic	ERJ-S03F2003V
R7	15.8K $\Omega$	RES SMD	1	0603	Panasonic	ERJ-3EKF1582V
L1	4.7 $\mu$ H	DCR=10.2m $\Omega$ , I <sub>r</sub> =10.9A	1	10.0x10.7x 5.4mm	Panasonic	ETQ-P5M4R7YFC
JH6		PCB Header, 36 POS	1	1X3	Amphenol	78511-136HLF
JH13, JH14, JH15, JH16	1598	Terminal Turret Triple 0.094" L (Test Points)	4	Through- Hole	Keystone Electronics	1598-2
U1	AP64500Q	Sync DC/DC Buck Converter	1	SO-8EP	Diodes Inc	AP64500QSP



**TYPICAL PERFORMANCE CHARACTERISTICS**

**Figure 6. Efficiency vs Output Current**

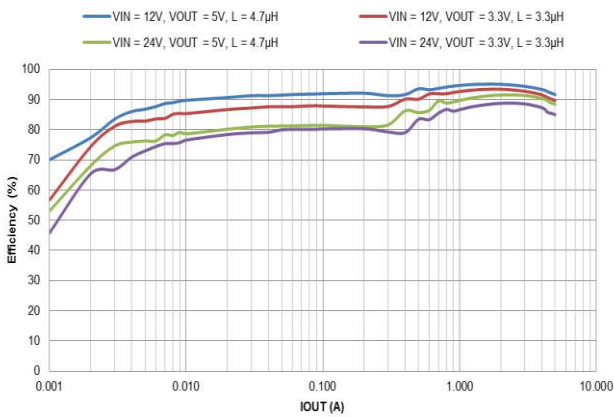

**Figure 7. Load Transient 3A to 5A**

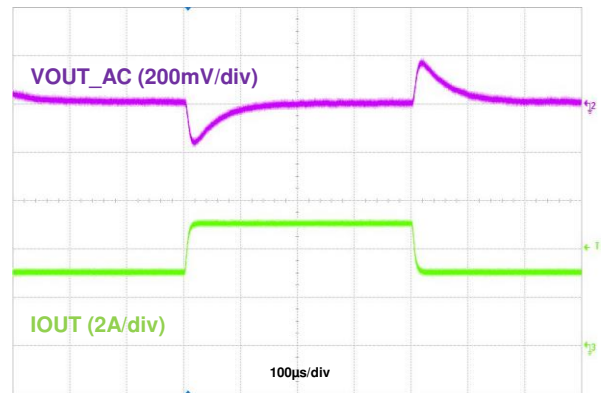

**Figure 8. Output Voltage Ripple, IOU=5A**

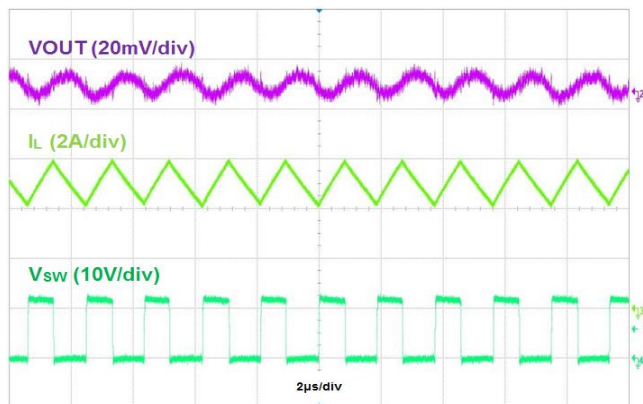

**Figure 9. Output Short Protection, IOU=5A**

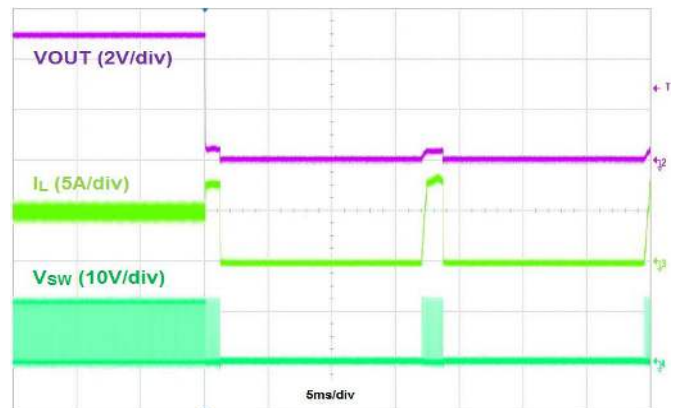



**IMPORTANT NOTICE**

DIODES INCORPORATED MAKES NO WARRANTY OF ANY KIND, EXPRESS OR IMPLIED, WITH REGARDS TO THIS DOCUMENT, INCLUDING, BUT NOT LIMITED TO, THE IMPLIED WARRANTIES OF MERCHANTABILITY AND FITNESS FOR A PARTICULAR PURPOSE (AND THEIR EQUIVALENTS UNDER THE LAWS OF ANY JURISDICTION).

Diodes Incorporated and its subsidiaries reserve the right to make modifications, enhancements, improvements, corrections or other changes without further notice to this document and any product described herein. Diodes Incorporated does not assume any liability arising out of the application or use of this document or any product described herein; neither does Diodes Incorporated convey any license under its patent or trademark rights, nor the rights of others. Any Customer or user of this document or products described herein in such applications shall assume all risks of such use and will agree to hold Diodes Incorporated and all the companies whose products are represented on Diodes Incorporated website, harmless against all damages.

Diodes Incorporated does not warrant or accept any liability whatsoever in respect of any products purchased through unauthorized sales channel.

Should Customers purchase or use Diodes Incorporated products for any unintended or unauthorized application, Customers shall indemnify and hold Diodes Incorporated and its representatives harmless against all claims, damages, expenses, and attorney fees arising out of, directly or indirectly, any claim of personal injury or death associated with such unintended or unauthorized application.

Products described herein may be covered by one or more United States, international or foreign patents pending. Product names and markings noted herein may also be covered by one or more United States, international or foreign trademarks.

This document is written in English but may be translated into multiple languages for reference. Only the English version of this document is the final and determinative format released by Diodes Incorporated.

**LIFE SUPPORT**

Diodes Incorporated products are specifically not authorized for use as critical components in life support devices or systems without the express written approval of the Chief Executive Officer of Diodes Incorporated. As used herein:

A. Life support devices or systems are devices or systems which:

1. are intended to implant into the body, or
2. support or sustain life and whose failure to perform when properly used in accordance with instructions for use provided in the labeling can be reasonably expected to result in significant injury to the user.

B. A critical component is any component in a life support device or system whose failure to perform can be reasonably expected to cause the failure of the life support device or to affect its safety or effectiveness.

Customers represent that they have all necessary expertise in the safety and regulatory ramifications of their life support devices or systems, and acknowledge and agree that they are solely responsible for all legal, regulatory and safety-related requirements concerning their products and any use of Diodes Incorporated products in such safety-critical, life support devices or systems, notwithstanding any devices- or systems-related information or support that may be provided by Diodes Incorporated. Further, Customers must fully indemnify Diodes Incorporated and its representatives against any damages arising out of the use of Diodes Incorporated products in such safety-critical, life support devices or systems.

Copyright © 2020, Diodes Incorporated

[www.diodes.com](http://www.diodes.com)