

2.5V/3.3V, High Bandwidth, Hot Insertion, 4-Bit, 2-Port Bus Switch with Individual Enables

Features

- Near-Zero propagation delay
- 5-ohm switches connect inputs to outputs
- High Bandwidth (>400 MHz)
- Rail-to-Rail, or 2.5V or 3.3V Switching
- 5V I/O Tolerant
- 2.5V Supply Voltage Operation
- Permits Hot Insertion
- Packaging (Pb-free & Green available):
 - 14-pin 150-mil wide plastic SOIC (W)
 - 14-pin 170-mil wide plastic TSSOP (L)
 - 16-pin 150-mil wide plastic QSOP (Q)

Description

Diodes' PI3C3125 and PI3C3126 are 2.5 volt or 3.3 volt, 4-bit bus switches designed with four individual 5-ohm bus switches with fast individual enables in an industry standard 74XX125/126 pinout. When enabled via the associated Bus Enable pin, the "A" pin is directly connected to the "B" pin for that particular gate. The bus switch introduces no additional propagation delay or additional ground bounce noise.

The PI3C3125 device has active LOW enables, and the PI3C3126 has active HIGH enables. It is very useful in switching signals that have high bandwidth (>400 MHz).

Applications

- High Bandwidth Data Switching
- Hot Docking

PI3C3125 Block Diagram

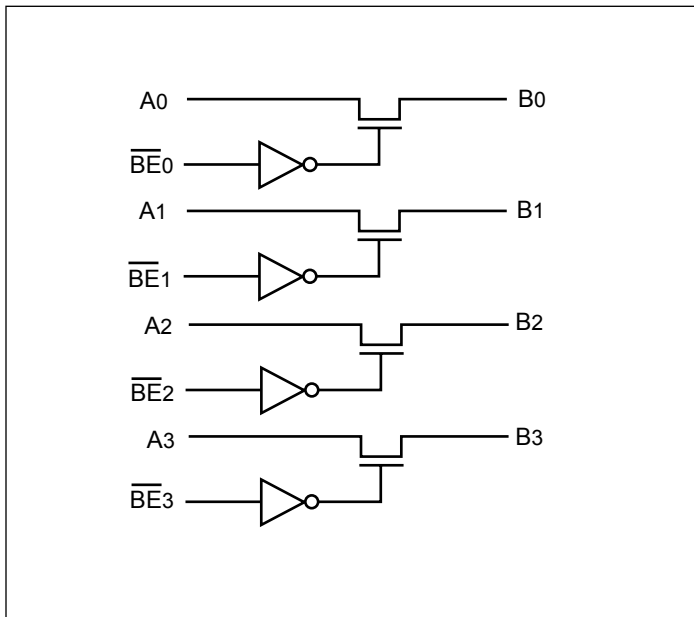

PI3C3126 Block Diagram

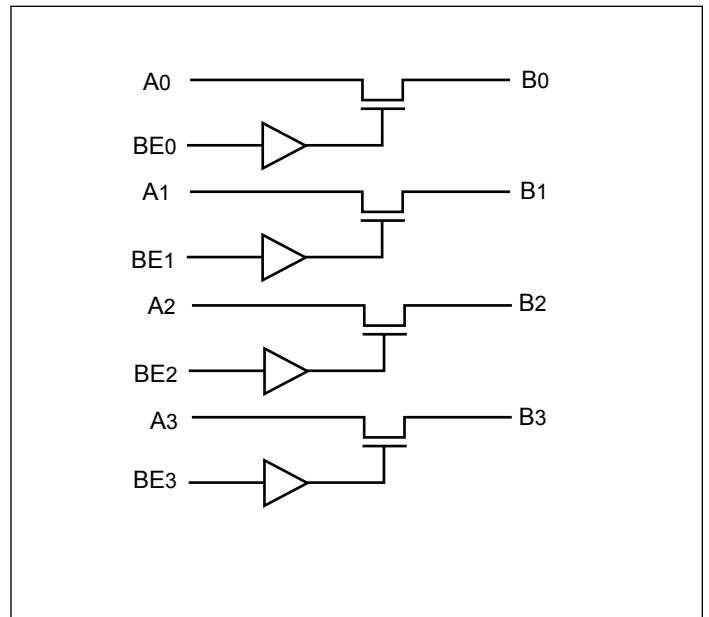

PI3C3125/PI3C3126

Maximum Ratings

(Above which the useful life may be impaired. For user guidelines, not tested.)

Storage Temperature	-65°C to +150°C
Ambient Temperature with Power Applied	-40°C to +85°C
Supply Voltage to Ground Potential (Inputs & V _{CC} Only).....	-0.5V to +4.6V
Supply Voltage to Ground Potential (Outputs & D/O Only) ..	-0.5V to +4.6V
DC Input Voltage	-0.5V to +5.5V
DC Output Current.....	120mA
Junction Temperature.....	125°C

Note:

Stresses greater than those listed under MAXIMUM RATINGS may cause permanent damage to the device. This is a stress rating only and functional operation of the device at these or any other conditions above those indicated in the operational sections of this specification is not implied. Exposure to absolute maximum rating conditions for extended periods may affect reliability.

PI3C3125 14-Pin Configuration

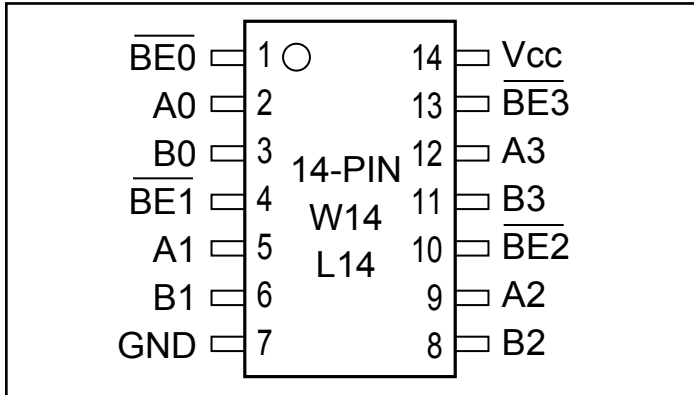

PI3C3126 14-Pin Configuration

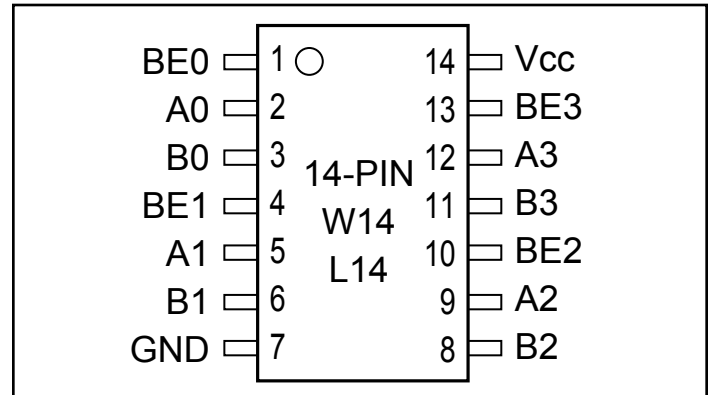

PI3C3125 16-Pin Configuration

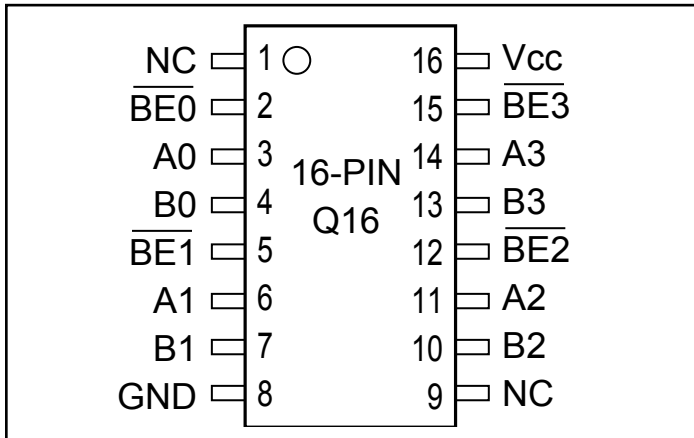

PI3C3126 16-Pin Configuration

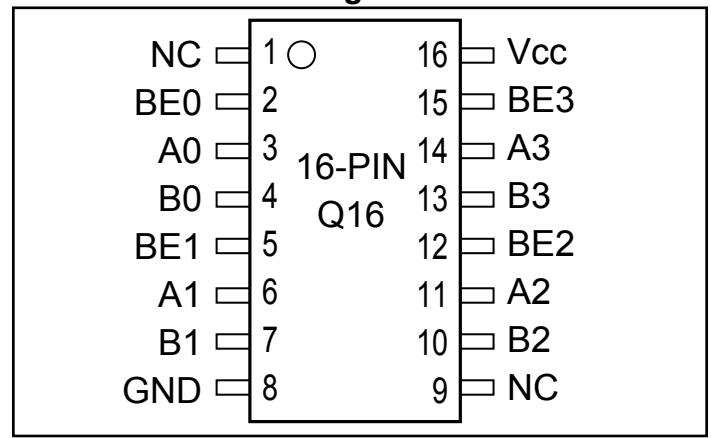

Pin Description

Pin Name	Description
\overline{BE}_n	Switch Enable (PI3C3125)
BE _n	Switch Enable (PI3C3126)
A3 - A0	Bus A
B3 - B0	Bus B
V _{CC}	Power
GND	Ground

Truth Table⁽¹⁾

PI3C3125 \overline{BE}_n	PI3C3126 BE _n	A _n	B _n	V _{CC}	Function
X*	X	Hi-Z	Hi-Z	GND	Disconnect
H	L	Hi-Z	Hi-Z	V _{CC}	Disconnect
L	H	B _n	A _n	V _{CC}	Disconnect

Note:

1. H = High Voltage Level, L = Low Voltage Level

Hi-Z = High Impedance, X = Don't Care

* A pull-up resistor should be provided for power-up protection.

DC Electrical Characteristics (Over Operating Range, $T_A = -40^\circ\text{C}$ to $+85^\circ\text{C}$, $V_{CC} = 3.3\text{V} \pm 10\%$)

Parameters	Description	Test Conditions ⁽¹⁾	Min.	Typ. ⁽²⁾	Max	Units
V_{IH}	Input HIGH Voltage	Guaranteed Logic HIGH Level	2.0			V
V_{IL}	Input LOW Voltage	Guaranteed Logic LOW Level -0.5		0.8		
I_{IH}	Input HIGH current	$V_{CC} = \text{Max.}, V_{IN} = V_{CC}$			± 1	μA
I_{IL}	Input LOW Current	$V_{CC} = \text{Max.}, V_{IN} = \text{GND}$			± 1	μA
$I_{OZH}^{(3)}$	High Impedance Output Current	$0 \leq A, B \leq V_{CC}$			± 1	
V_{IK}	Clamp Diode Voltage	$V_{CC} = \text{Min.}, I_{IN} = -18\text{mA}$		-0.73	-1.2	V
R_{ON}	Switch ON Resistance ⁽⁴⁾	$V_{CC} = \text{Min.}, V_{IN} = 0.0\text{V}, I_{ON} = 48\text{mA}$ or 60mA $V_{CC} = \text{Min.}, V_{IN} = 2.4\text{V}, I_{ON} = 15\text{mA}$		5 8	7 15	Ω

Notes:

- For Max. or Min. conditions, use appropriate value specified under Electrical Characteristics for the applicable device type.
- Typical values are at $V_{CC} = 3.3\text{V}$, $T_A = 25^\circ\text{C}$ ambient and maximum loading.
- Not more than one output should be shorted at one time. Duration of the test should not exceed one second.
- Measured by the voltage drop between A and B pin at indicated current through the switch. ON resistance is determined by the lower of the voltages on the two (A,B) pins.

Capacitance ($T_A = 25^\circ\text{C}$, $f = 1\text{MHz}$)

Parameters ⁽¹⁾	Description	Test Conditions	Typ.	Units
C_{IN}	Input Capacitance	$V_{IN} = 0\text{V}$	3.5	pF
C_{OFF}	A/B Capacitance, Switch Off	$V_{IN} = 0\text{V}$	5.0	
C_{ON}	A/B Capacitance, Switch On	$V_{IN} = 0\text{V}$	10.0	

Notes:

- This parameter is determined by device characterization but is not production tested.

Power Supply Characteristics

Parameters	Description	Test Conditions		Min.	Typ. ⁽²⁾	Max.	Units
I_{CC}	Quiescent Power Supply Current	$V_{CC} = \text{Max}$	$V_{IN} = \text{GND}$ or V_{CC}		260	500	μA
ΔI_{CC}	Supply Current per Input HIGH	$V_{CC} = \text{Max}$	$V_{IN} = 3.0\text{V}^{(3)}$			750	

Notes:

- For Max. or Min. conditions, use appropriate value specified under Electrical Characteristics for the applicable device.
- Typical values are at $V_{CC} = 3.3\text{V}$, $+25^\circ\text{C}$ ambient.
- Per driven input (control input only); A and B pins do not contribute to ΔI_{CC} .

PI3C3125/PI3C3126

PI3C3125/PI3C3126 Switching Characteristics over 3.3V Operating Range

Parameters	Description	Conditions	PI3C3125/PI3C3126		Units
			Com.		
			Min.	Max.	
t _{PLH} t _{PHL}	Propogation Delay ^(1,2) A to B, B to A	C _L = 50pF R _L = 500Ω		0.25	ns
t _{PZH} t _{PZL}	Bus Enable Time	C _L = 50pF R _L = 500Ω	1.5	6.5	
t _{PHZ} t _{PLZ}	Bus Disable Time	R = 500Ω	1.5	5.5	

Notes:

1. This parameter is guaranteed but not tested on Propagation Delays.
2. The bus switch contributes no propagational delay other than the RC delay of the ON resistance of the switch and the load capacitance. The time constant for the switch alone is of the order of 0.25ns for 50pF load. Since this time constant is much smaller than the rise/fall times of typical driving signals, it adds very little propagational delay to the system. Propagational delay of the bus switch when used in a system is determined by the driving circuit on the driving side of the switch and its interaction with the load on the driven side.

PI3C3125/PI3C3126 Switching Characteristics over 2.5V Operating Range

Parameters	Description	Conditions	PI3C3125/PI3C3126		Units
			Com.		
			Min.	Max.	
t _{PLH} t _{PHL}	Propogation Delay ^(1,2) A to B, B to A	C _L = 50pF R _L = 500Ω		0.25	ns
t _{PZH} t _{PZL}	Bus Enable Time	C _L = 50pF R _L = 500Ω	1.5	9.8	
t _{PHZ} t _{PLZ}	Bus Disable Time	R = 500Ω	1.5	8.3	

Notes:

1. This parameter is guaranteed but not tested on Propagation Delays.
2. The bus switch contributes no propagational delay other than the RC delay of the ON resistance of the switch and the load capacitance. The time constant for the switch alone is of the order of 0.25ns for 50pF load. Since this time constant is much smaller than the rise/fall times of typical driving signals, it adds very little propagational delay to the system. Propagational delay of the bus switch when used in a system is determined by the driving circuit on the driving side of the switch and its interaction with the load on the driven side.

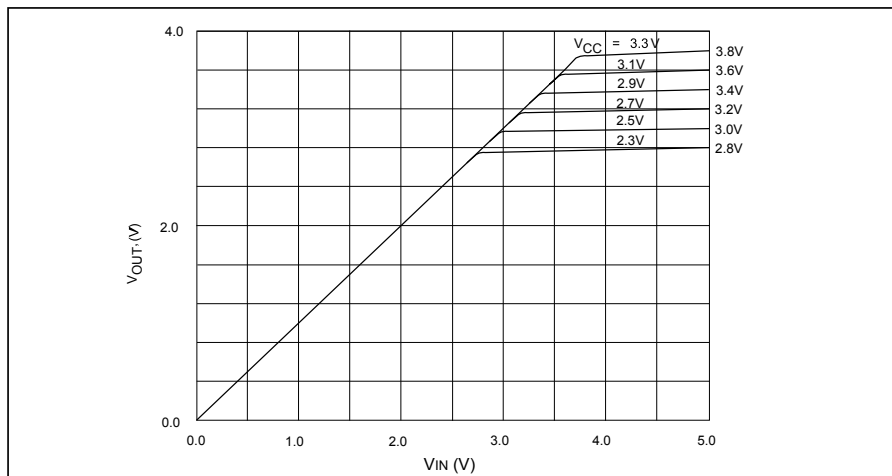

Switch Output Voltage vs. Input Voltage over Various Supply Voltages

PI3C3125/PI3C3126

Packaging Mechanical: 14-SOIC (W)

SYMBOLS	MIN.	NOM.	MAX.
A	—	—	1.75
A1	0.10	—	0.25
A2	1.25	—	—
b	0.31	—	0.51
c	0.10	—	0.25
D	8.55	8.65	8.75
E	5.80	6.00	6.20
E1	3.70	3.90	4.10
e	1.27 BSC		
L	0.40	—	1.27
L1	1.04 REF		
h	0.25	—	0.50
θ°	0	—	8

SEATING PLANE

GAUGE PLANE

SEATING PLANE

0.10 C

0.25

θ°

L

L1

hX45°

14

8

1

7

E1

E

D

A

A2

A1

e

b

c

NOTES:

1. ALL DIMENSIONS ARE IN mm. ANGLES IN DEGREES.
2. JEDEC MS-012
3. DIMENSIONS DOES NOT INCLUDE MOLD FLASH, PROTRUSIONS OR GATE BURRS.

PERICOM Enabling Serial Connectivity		DATE: 03/24/16
DESCRIPTION: 14-Pin, 150mil Wide SOIC		
PACKAGE CODE: W (W14)		
DOCUMENT CONTROL #: PD-1002	REVISION: E	

16-0055

PI3C3125/PI3C3126

Packaging Mechanical: 14-TSSOP (L)

SYMBOLS	MIN.	NOM.	MAX.
A	–	–	1.20
A1	0.05	–	0.15
A2	0.80	1.00	1.05
b	0.19	–	0.30
c	0.09	–	0.20
D	4.90	5.00	5.10
E1	4.30	4.40	4.50
E	6.20	6.40	6.60
e	0.65 BSC		
L1	1.00 REF		
L	0.45	0.60	0.75
S	0.20	–	–
θ	0°	–	8°

NOTES:
 1. ALL DIMENSIONS IN MILLIMETERS. ANGLES IN DEGREES.
 2. JEDEC MO-153F
 3. DIMENSIONS DOES NOT INCLUDE MOLD FLASH, PROTRUSIONS OR GATE BURRS.

		DATE: 03/24/16
DESCRIPTION: 14-Pin, 173mil Wide TSSOP		
PACKAGE CODE: L (L14)		
DOCUMENT CONTROL #: PD-1309	REVISION: E	

16-0060

PI3C3125/PI3C3126

Packaging Mechanical: 16-QSOP (Q)

SYMBOLS	MIN.	NOM.	MAX.
A	—	—	0.069
A1	0.004	—	0.0098
A2	0.049	—	—
b	0.008	—	0.012
c	0.004	—	0.010
D	0.189	0.193	0.197
E1	0.150	0.154	0.158
E	0.228	0.236	0.244
L	0.016	—	0.050
L1	0.041 REF.		
e	0.025 BSC.		
θ°	0	—	8

UNIT : INCH

0.004 C
SEATING PLANE
Gauge Plane
SEATING PLANE
0.010
DETAIL A

PERICOM
Enabling Serial Connectivity

DATE: 04/08/16

DESCRIPTION: 16-Pin, 150mil Wide QSOP

PACKAGE CODE: Q (Q16)

DOCUMENT CONTROL #: PD-1201

REVISION: H

NOTES:
1. ALL DIMENSIONS IN INCH. ANGLES IN DEGREES.
2. JEDEC MO-137E
3. DIMENSIONS DOES NOT INCLUDE MOLD FLASH, PROTRUSIONS OR GATE BURRS.

16-0056

For latest package info.

please check: <http://www.diodes.com/design/support/packaging/pericom-packaging/packaging-mechanicals-and-thermal-characteristics/>

Ordering Information

Ordering Code	Packaging Code	Description
PI3C3125LEX	L	14-pin, 173mil Wide (TSSOP)
PI3C3125WEX	W	14-pin, 150mil Wide (SOIC)
PI3C3126LEX	L	14-pin, 173mil Wide (TSSOP)
PI3C3126QEX	Q	16-pin, 150mil Wide (QSOP)

Notes:

- Thermal characteristics can be found on the company web site at www.diodes.com/design/support/packaging/
- E = Pb-free and Green
- X suffix = Tape/Reel

IMPORTANT NOTICE

DIODES INCORPORATED MAKES NO WARRANTY OF ANY KIND, EXPRESS OR IMPLIED, WITH REGARDS TO THIS DOCUMENT, INCLUDING, BUT NOT LIMITED TO, THE IMPLIED WARRANTIES OF MERCHANTABILITY AND FITNESS FOR A PARTICULAR PURPOSE (AND THEIR EQUIVALENTS UNDER THE LAWS OF ANY JURISDICTION).

Diodes Incorporated and its subsidiaries reserve the right to make modifications, enhancements, improvements, corrections or other changes without further notice to this document and any product described herein. Diodes Incorporated does not assume any liability arising out of the application or use of this document or any product described herein; neither does Diodes Incorporated convey any license under its patent or trademark rights, nor the rights of others. Any Customer or user of this document or products described herein in such applications shall assume all risks of such use and will agree to hold Diodes Incorporated and all the companies whose products are represented on Diodes Incorporated website, harmless against all damages.

Diodes Incorporated does not warrant or accept any liability whatsoever in respect of any products purchased through unauthorized sales channel.

Should Customers purchase or use Diodes Incorporated products for any unintended or unauthorized application, Customers shall indemnify and hold Diodes Incorporated and its representatives harmless against all claims, damages, expenses, and attorney fees arising out of, directly or indirectly, any claim of personal injury or death associated with such unintended or unauthorized application.

Products described herein may be covered by one or more United States, international or foreign patents pending. Product names and markings noted herein may also be covered by one or more United States, international or foreign trademarks.

This document is written in English but may be translated into multiple languages for reference. Only the English version of this document is the final and definitive format released by Diodes Incorporated.

LIFE SUPPORT

Diodes Incorporated products are specifically not authorized for use as critical components in life support devices or systems without the express written approval of the Chief Executive Officer of Diodes Incorporated. As used herein:

A. Life support devices or systems are devices or systems which:

1. are intended to implant into the body, or
 2. support or sustain life and whose failure to perform when properly used in accordance with instructions for use provided in the labeling can be reasonably expected to result in significant injury to the user.
- B. A critical component is any component in a life support device or system whose failure to perform can be reasonably expected to cause the failure of the life support device or to affect its safety or effectiveness.

Customers represent that they have all necessary expertise in the safety and regulatory ramifications of their life support devices or systems, and acknowledge and agree that they are solely responsible for all legal, regulatory and safety-related requirements concerning their products and any use of Diodes Incorporated products in such safety-critical, life support devices or systems, notwithstanding any devices- or systems-related information or support that may be provided by Diodes Incorporated. Further, Customers must fully indemnify Diodes Incorporated and its representatives against any damages arising out of the use of Diodes Incorporated products in such safety-critical, life support devices or systems.

Copyright © 2016, Diodes Incorporated
www.diodes.com