

THIS DRAWING IS UNPUBLISHED. RELEASED FOR PUBLICATION
 © COPYRIGHT - TE Connectivity Ltd. ALL RIGHTS RESERVED.

REVISIONS					
P	LTR	DESCRIPTION	DATE	DWN	APVD
D		REV, RDRW, & SM PKG PER 0720-0040-93	3-29-93	-	DAP
D1		REVISED PER ECO-17-008808	09FEB2018	RS	DR

AMP WIRE RANGE	E13288 Listed
16-14 AWG SOLID OR STRANDED	16-14 AWG SOLID OR STRANDED
LR7189 Certified	MILITARY P/N AND CLASS
16-14 AWG SOLID OR STRANDED	NOT APPLICABLE

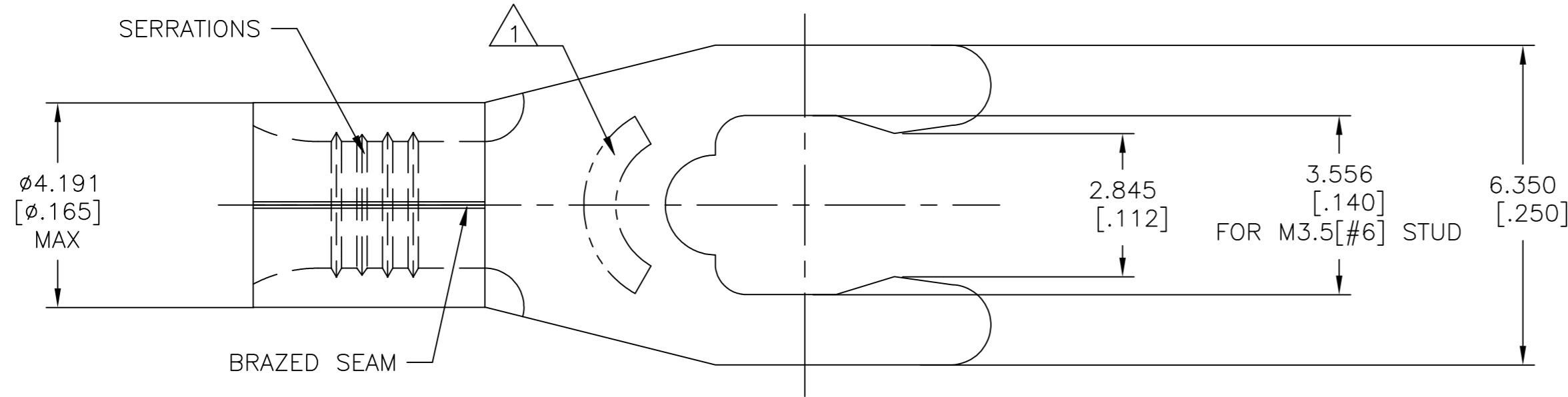

STAMP 6S AMP 16-14* APPROX AS SHOWN
 6S INDICATES STUD SIZE

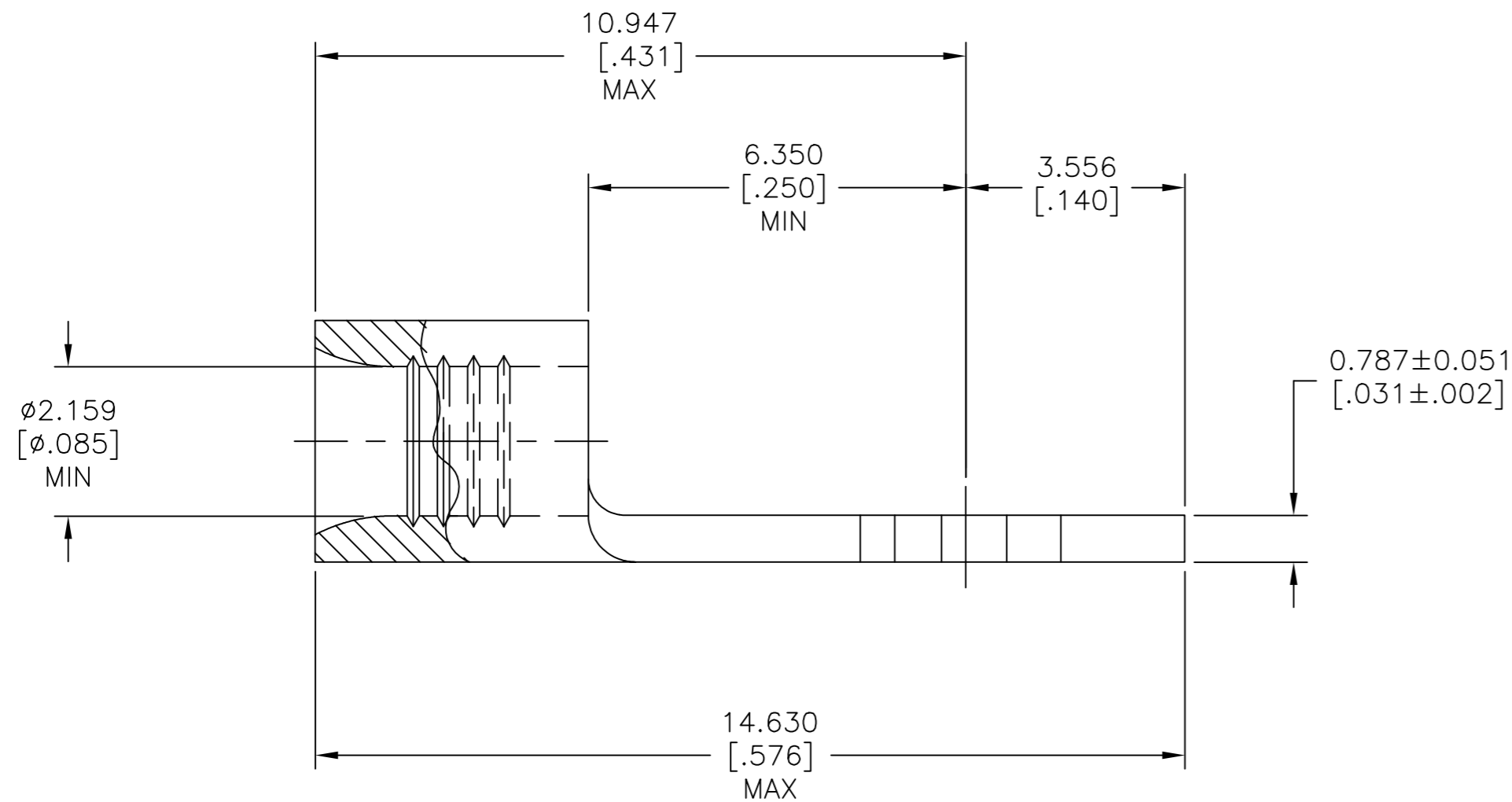

5000	ON TAPE	53123-2
1000	LOOSE PIECE	53123-1
QUANTITY	PACKAGING TYPE	PART NO

AMP INCORPORATED CUSTOMER SERVICE SYSTEMS			THIS DRAWING IS A CONTROLLED DOCUMENT.		DWN TA BRINKMAN 3-29-93	TE Connectivity Ltd.		
FOR ADDITIONAL PRODUCT INFORMATION OR COPIES OF DRAWINGS AND TECHNICAL DOCUMENTS	PRODUCT INFORMATION CENTER 1-800-522-6752	MAX RECOMMENDED OPERATING TEMPERATURE: 170°C [338°F] MAX	DIMENSIONS: mm [INCHES]	TOLERANCES UNLESS OTHERWISE SPECIFIED:	CHK DA PATTERSON 3-29-93	NAME DE MILLER		
FOR APPLICATION TOOLING INFORMATION	TOOLING ASSISTANCE CENTER 1-800-722-1111	VOLTAGE RATING: NOT APPLICABLE		0 PLC ± - 1 PLC ± - 2 PLC ± - 3 PLC ± 0.127[.005] 4 PLC ± - ANGLES ± -	APVD DE MILLER 3-29-93	PRODUCT SPEC UL 486 A-B		
FOR ORDER ENTRY	1-800-526-5142	WIRE CROSS SECTIONAL AREA RANGE, 1.04-2.62mm²[2,050-5,180] CIR MILS SOLID OR STRANDED	MATERIAL PHOSPHOR BRONZE PER ASTM B-103 ANNEALED	FINISH TIN PLATE 0.00254[.000100] MIN THK PER ASTM B545	APPLICATION SPEC -	SIZE A2	CAGE CODE 00779	DRAWING NO C=53123
CUSTOMER DRAWING					WEIGHT	RESTRICTED TO	-	
					SCALE 10:1	SHEET 1 of 1	REV D1	