

Customer Information Sheet

DRAWING No.: M30-1010046 SHEET 2 OF 2 IF IN DOUBT - ASK © NOT TO SCALE THIRD ANGLE PROJECTION ALL DIMENSIONS IN mm

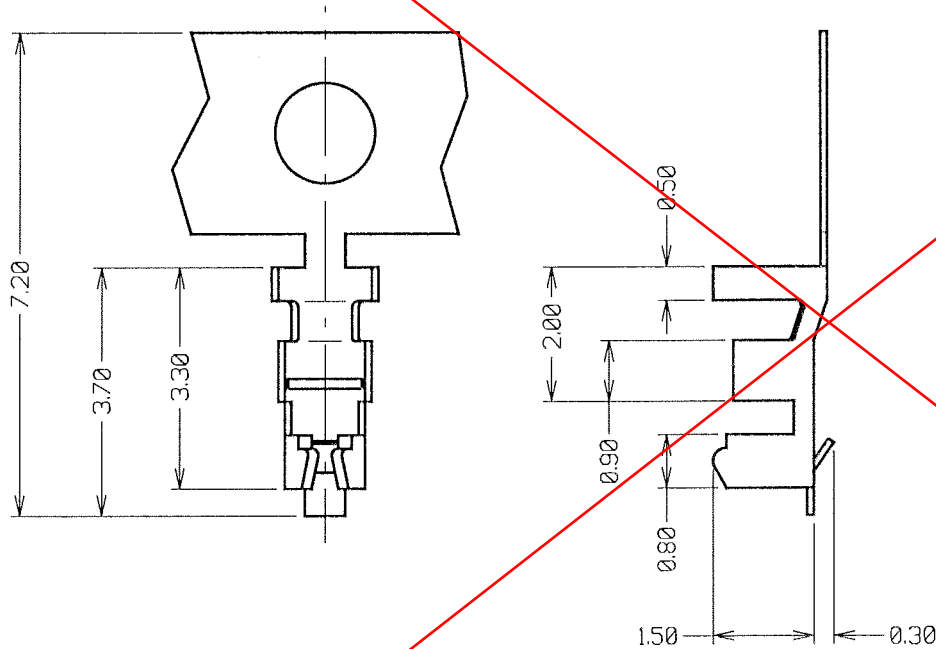

NOTES:

1. CABLE SIZES 26, 28 AND 30 AWG CAN BE USED WITH THIS CRIMP CONTACT. INSULATION DIAMETER TO BE $\varnothing 0.65$ TO $\varnothing 1.00$ mm.
2. CABLE TO BE STRIPPED BY A LENGTH OF 1.2 TO 1.9mm.
3. FOR USE IN CRIMP HOUSING M30-110XX00. ALL RELEVANT SPECIFICATIONS ARE QUOTED ON THIS DRAWING.
4. ALL TOLERANCES ± 0.30 UNLESS OTHERWISE STATED.
5. SUPPLIED IN STRIPS OF 105, TUBE PACKED. UP TO 108 TUBES PACKED PER BOX.

OBSOLETE

JMB	1	17.08.05	8688
NAME	ISS.	DATE	C/NOTE
APPROVED: <i>[Signature]</i>			
CHECKED: <i>[Signature]</i>			
DRAWN: J BROOKES			
CUSTOMER REF.:			
ASSEMBLY ORG.:			

HARWIN

THIS DRAWING AND ANY INFORMATION OR DESCRIPTIVE MATTER SET OUT HEREON ARE CONFIDENTIAL AND COPYRIGHT PROPERTY OF THE HARWIN GROUP AND MUST NOT BE DISCLOSED, LOANED, COPIED OR USED FOR MANUFACTURING, TENDERING OR FOR ANY OTHER PURPOSE WITHOUT THEIR WRITTEN PERMISSION.

TOLERANCES
X. - ± 1 mm
X.X - ± 0.25 mm
X.XX - ± 0.10 mm
X.XXX - ± 0.01 mm
ANGLES - $\pm 5^\circ$
UNLESS STATED

MATERIAL: PHOSPHOR BRONZE
FINISH: 100% TIN
S/AREA: mm²

TITLE: 1.25mm FEMALE CRIMP TERMINAL (LOOSE)
DRAWING NUMBER: M30-1010046
SHT 2 OF 2

HARWIN USA TEL: 603 893 5376 FAX: 603 893 5396 mjs@harwin.com	HARWIN Europe (UK) TEL: 023 9231 4545 FAX: 023 9231 4590 mjs@harwin.co.uk	HARWIN Asia TEL: +65 6 779 4909 FAX: +65 6 779 3868 mjs@harwin.com.sg
--	--	--