

NUT

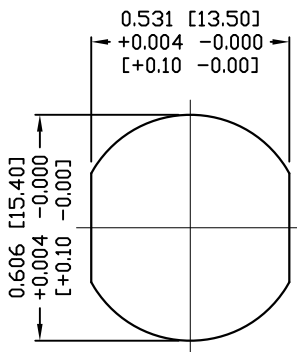

RECOMMEND PANEL CUT-OUT

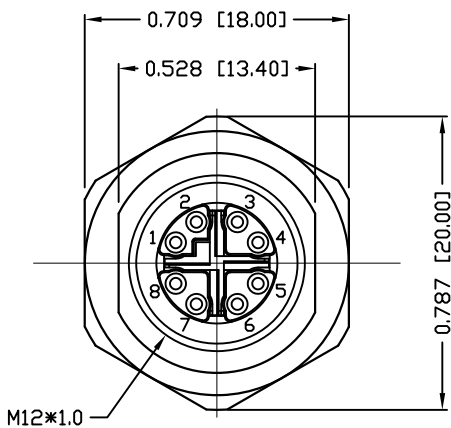
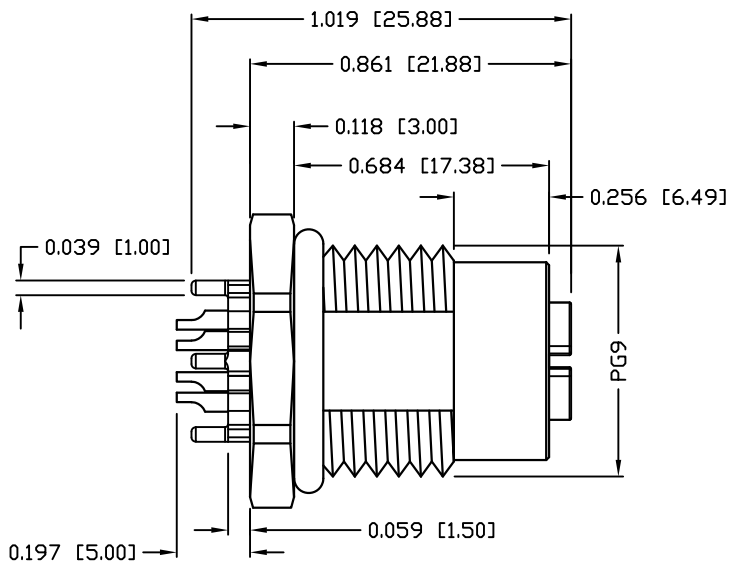

NOTE:

MATERIAL	
HOUSING:	PA66 UL94V-0, BLACK
CONTACT:	BRASS
NUT:	BRASS
SHELL:	BRASS
O-RING:	EPDM, BLACK
X-SHELL:	ZINC ALLOY
FINISH	
CONTACT:	GOLD 10u" MIN. OVER 50u" NICKEL
NUT:	NICKEL PLATED
SHELL:	NICKEL PLATED
X-SHELL:	NICKEL PLATED
ELECTRICAL	
RATED CURRENT:	0.5A
RATED VOLTAGE:	50VAC/60VDC
INSULATION RESISTANCE:	100 MOhms MIN.
CONTACT RESISTANCE:	10 mOhms MAX.
WATER PROOF:	IP67
ENVIRONMENT	
OPERATION TEMPERATURE:	-40°C TO +85°C
MAX WIRE AWG:	24

859-X08-203R004

- 3 = BRASS/NICKEL SHELL & NUT
- S = STAINLESS STEEL SHELL & NUT
- 1 = GOLD FLASH
- 4 = 10u" GOLD

RoHS COMPLIANT

UNITS = INCHES [MM]

DO NOT SCALE FROM DRAWING



THESE DRAWINGS AND SPECIFICATIONS ARE THE PROPERTY OF NorComp AND SHALL NOT BE REPRODUCED, COPIED OR USED AS THE BASIS FOR THE MANUFACTURE OR SALE OF APPARATUS WITHOUT WRITTEN PERMISSION.

DRAWN: M. SIGMON

DATE: 04-24-17

NorComp

SCALE: NTS SHEET 1 OF 1 REV 5

DWG NO. 859-X08-203R004