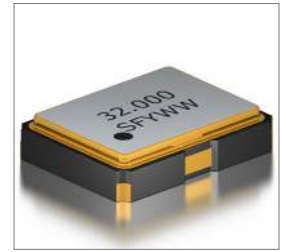
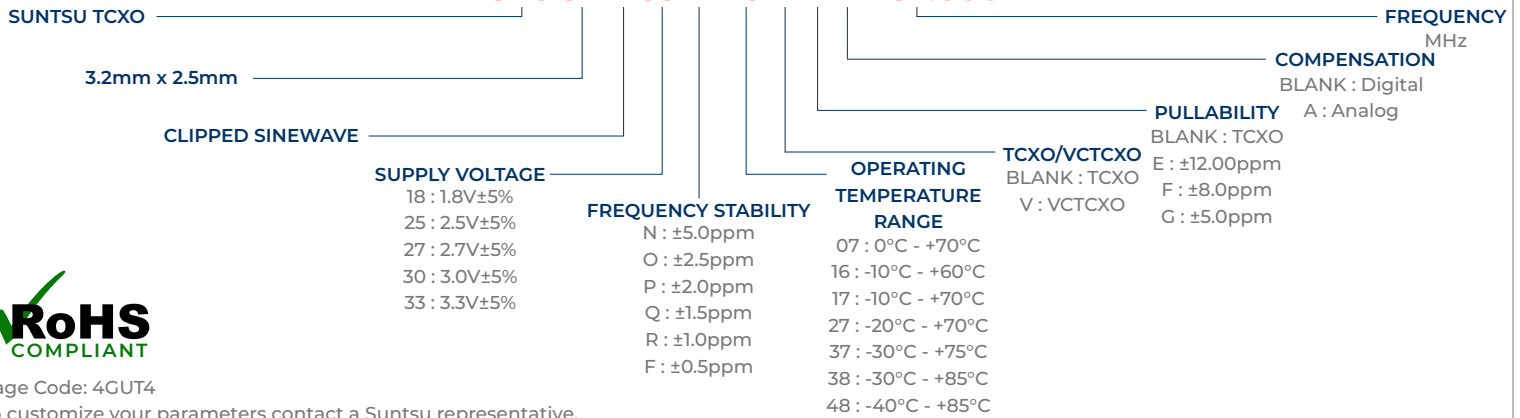

Features
<ul style="list-style-type: none"> ±0.5ppm (Frequency Stability) Available Clipped Sinewave (VC)TCXO Tape and Reel

Applications
<ul style="list-style-type: none"> GPS Mobile Communication Equipment Cellular And Cordless Phones IP Networking

Part Numbering Guide
STC 32 K 33 R 48 V E A - 32.000M

Cage Code: 4GUT4

To customize your parameters contact a Suntsu representative.

Electrical Parameters	Units	Minimum	Typical	Maximum	Remarks
Frequency Range	MHz	6		40	
Frequency Tolerance at +25°C	ppm	-1.5		+1.5	1 hour after reflow.
Freq. Stability vs. Op Temp.	ppm	-0.5		+0.5	See part numbering guide for options.
Freq. Stability vs. Supply Voltage	ppm	-0.3		+0.3	V _{DD} ±5% change.
Freq. Stability vs. Load	ppm	-0.3		+0.3	±10% change
Freq. Stability vs. Aging	ppm	-1.0		+1.0	1 Year
Operating Temperature	°C	-40		+85	See part numbering guide for options.
Storage Temperature	°C	-55		+125	
Supply Voltage (V _{DD})	V	3.135	3.3	3.465	See part numbering guide for options.
Current (I _{DD})	mA			2	
Control Current (VC, VCTCXO)	V	0		V _{DD}	Center Voltage : V _{DD} *50%
Pullability (VCTCXO)	ppm	±5.0		±12.0	See part numbering guide for options.
Linearity (VCTCXO)	%			10	
Output Load (Clipped Sinewave)	kΩ//pF			10//10	
Output Logic Levels	V _{P-P}	0.8			
Symmetry (Duty Cycle)	%	40	50	60	
Start-Up Time	ms			3	
VC Input Impedance (VCTCXO)	kΩ	100			
Phase Noise (Typical) 10Hz Offset	dBc/Hz		-85		
Phase Noise (Typical) 100Hz Offset	dBc/Hz		-115		
Phase Noise (Typical) 1KHz Offset	dBc/Hz		-135		
Phase Noise (Typical) 10KHz Offset	dBc/Hz		-145		
Phase Noise (Typical) 100KHz Offset	dBc/Hz		-150		

Outline Drawing

All dimensions are in millimeters (mm) unless otherwise noted. Drawings are not to scale.

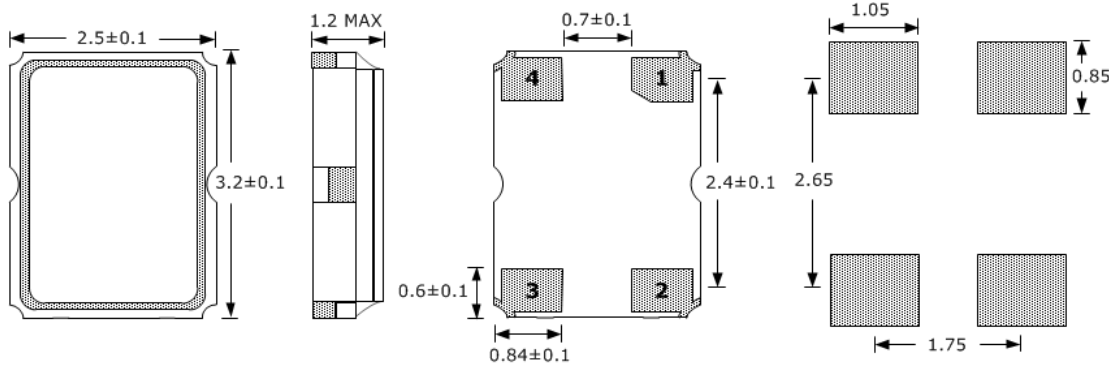

PIN	FUNCTION
1	V _c (VCTCXO) NC OR GND (TCXO)
2	GND
3	OUTPUT
4	V _{DD}

Test Circuit (Clipped Sinewave)

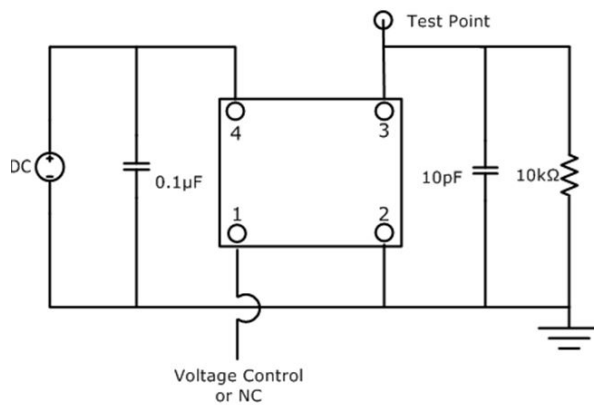

Waveform (Clipped Sinewave)

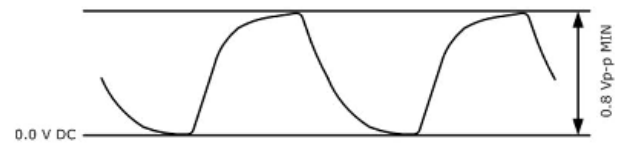

Typical Phase Noise (Measured By Agilent E5052A)

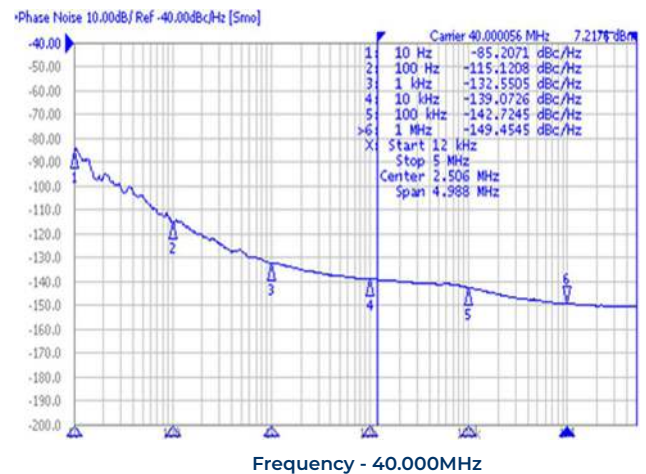
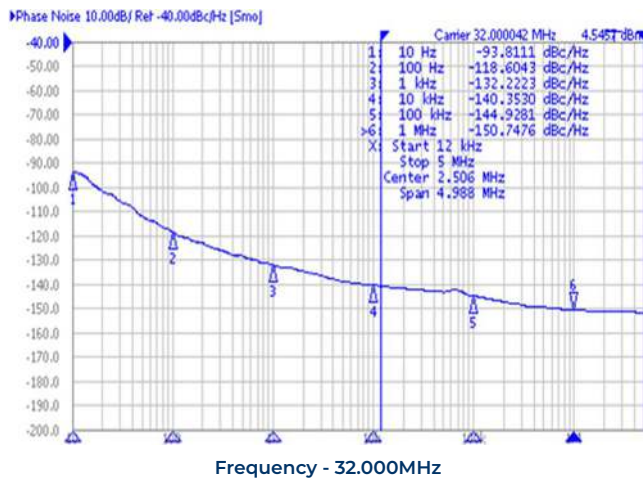

Jitter Performance (Measured By Agilent E5052A)

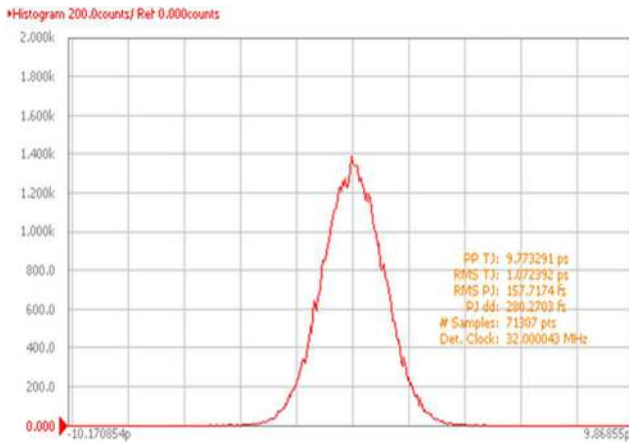

Frequency - 32.000MHz

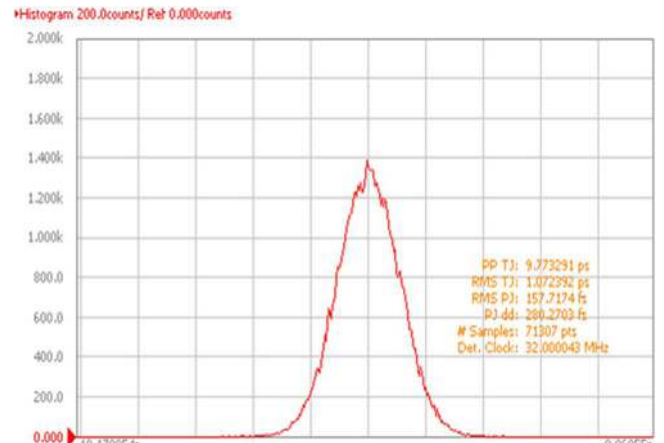

Frequency - 40.000MHz

Tape And Reel Dimensions

All dimensions are in millimeters (mm) unless otherwise noted. Drawings are not to scale.

3,000pcs/Reel

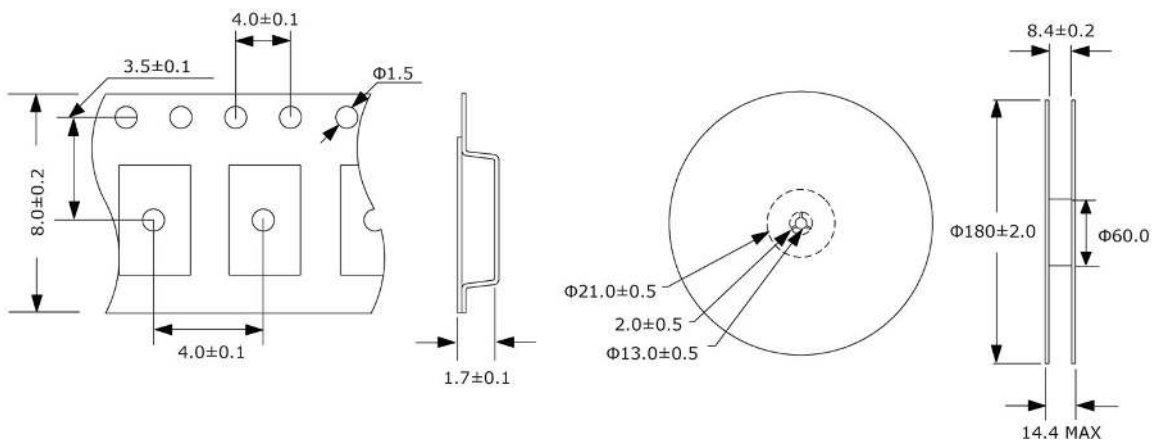

Reflow Profile & Part Marking

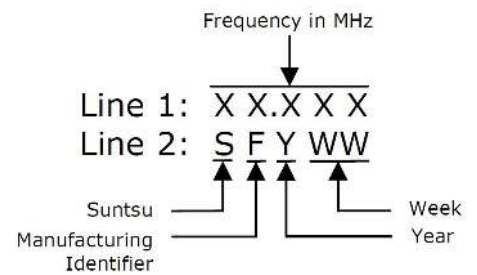
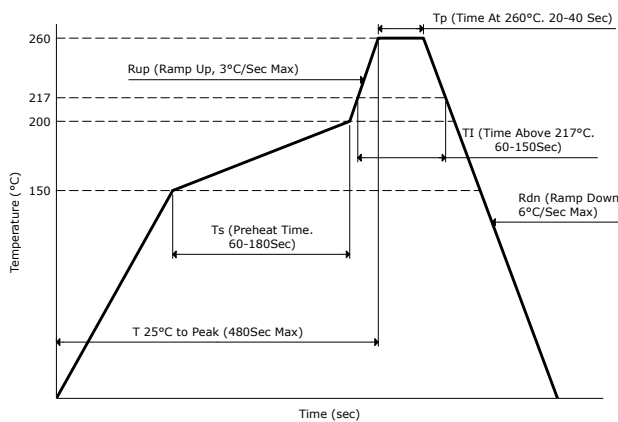

Environmental Specifications		Mechanical Specifications	
Temperature Cycling	MIL-STD-883, Method 1010, Condition B	Mechanical Shock	MIL-STD-202, Method 213, Condition B
Fine Leak Test	MIL-STD-883, Method 1014, Condition A	Vibration	MIL-STD-883, Method 2007, Condition A
Gross Leak Test	MIL-STD-883, Method 1014, Condition C	Moisture Resistance	MIL-STD-883, Method 1004
Solderability	MIL-STD-883, Method 2003	Resistance to Solvents	MIL-STD-202, Method 215
Moisture Sensitivity	J-STD-020, MSL 1	Resistance to Soldering Heat	MIL-STD-202, Method 210, Condition K