

Silicon Power Schottky Diode

$V_{RRM} = 150\text{ V} - 200\text{ V}$

$I_{F(AV)} = 200\text{ A}$

Features

- High Surge Capability
- Types from 150 V to 200 V V_{RRM}
- Not ESD Sensitive

D-67 Package

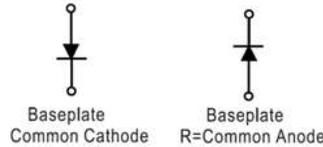

Maximum ratings, at $T_j = 25\text{ }^\circ\text{C}$, unless otherwise specified ("R" devices have leads reversed)

| Parameter | Symbol | Conditions | MBRH200150(R) | MBRH200200(R) | Unit |
|---------------------------------|-----------|------------|---------------|---------------|------------------|
| Repetitive peak reverse voltage | V_{RRM} | | 150 | 200 | V |
| RMS reverse voltage | V_{RMS} | | 106 | 141 | V |
| DC blocking voltage | V_{DC} | | 150 | 150 | V |
| Operating temperature | T_j | | -55 to 150 | -55 to 150 | $^\circ\text{C}$ |
| Storage temperature | T_{stg} | | -55 to 150 | -55 to 150 | $^\circ\text{C}$ |

Electrical characteristics, at $T_j = 25\text{ }^\circ\text{C}$, unless otherwise specified

| Parameter | Symbol | Conditions | MBRH200150(R) | MBRH200200(R) | Unit |
|--|-------------|--|---------------|---------------|------|
| Average forward current (per pkg) | $I_{F(AV)}$ | $T_C = 125\text{ }^\circ\text{C}$ | 200 | 200 | A |
| Peak forward surge current | I_{FSM} | $t_p = 8.3\text{ ms}$, half sine | 3000 | 3000 | A |
| Maximum instantaneous forward voltage | V_F | $I_{FM} = 200\text{ A}$, $T_j = 25\text{ }^\circ\text{C}$ | 0.88 | 0.92 | V |
| Maximum instantaneous reverse current at rated DC blocking voltage | I_R | $T_j = 25\text{ }^\circ\text{C}$ | 1 | 1 | mA |
| | | $T_j = 100\text{ }^\circ\text{C}$ | 10 | 10 | |
| | | $T_j = 150\text{ }^\circ\text{C}$ | 50 | 50 | |

Thermal characteristics

| Parameter | Symbol | Conditions | MBRH200150(R) | MBRH200200(R) | Unit |
|-----------------------------------|-----------------|------------|---------------|---------------|--------------------|
| Thermal resistance, junction-case | $R_{\theta JC}$ | | 0.35 | 0.35 | $^\circ\text{C/W}$ |

Figure .1- Typical Forward Characteristics

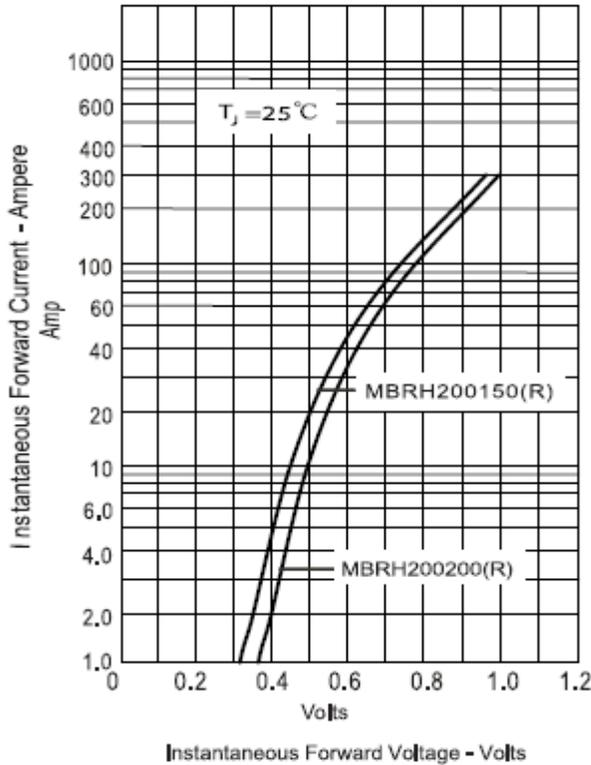

Figure .2- Forward Derating Curve

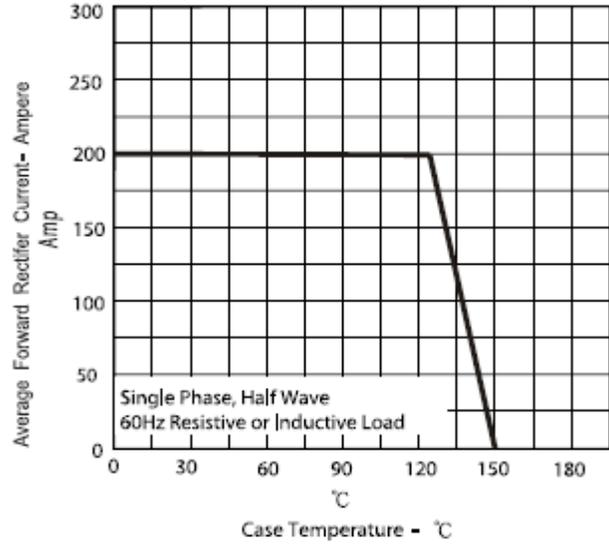

Figure.3- Peak Forward Surge Current

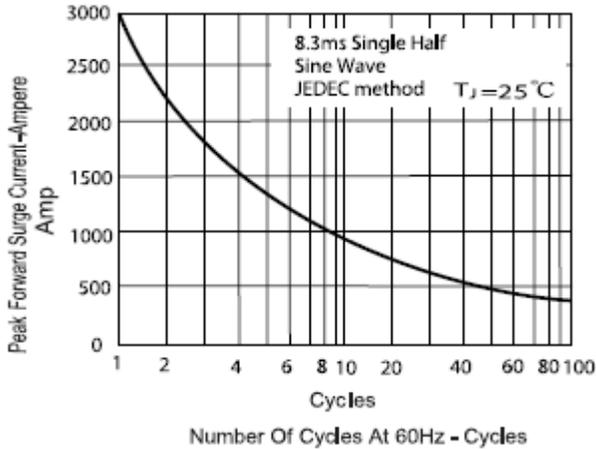
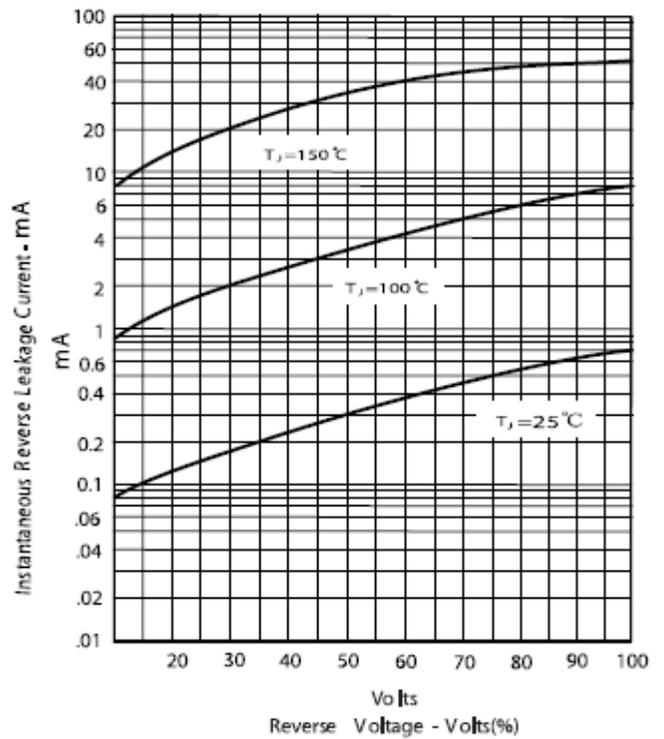
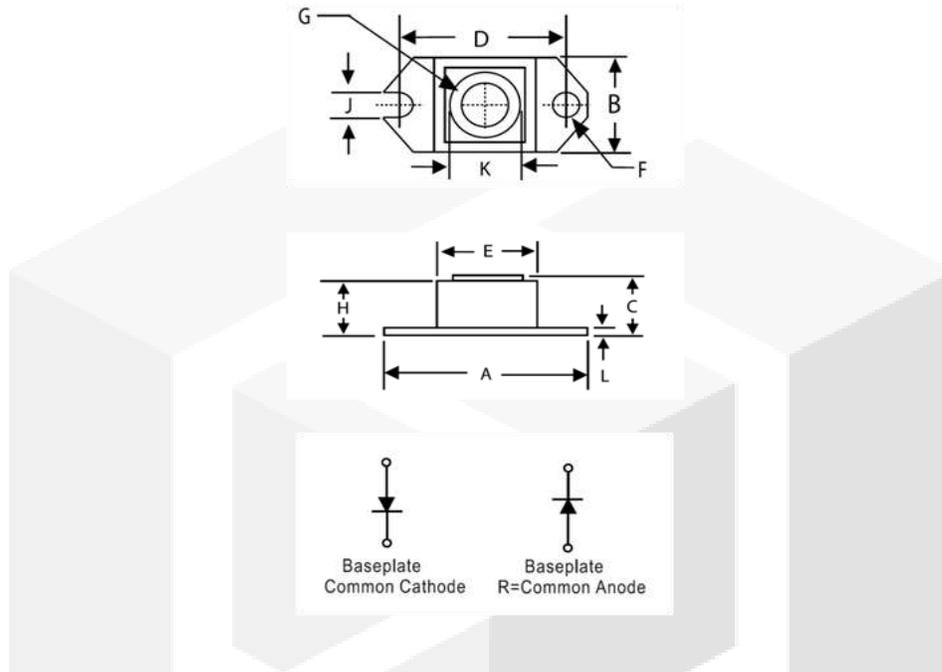

Figure .4 Typical Reverse Characteristics



Package dimensions and terminal configuration

Product is marked with part number and terminal configuration.



| DIMENSIONS | | | | | |
|------------|-------------|-------|-------|-------|------|
| DIM | INCHES | | MM | | NOTE |
| | MIN | MAX | MIN | MAX | |
| A | 1.515 | 1.560 | 38.48 | 39.62 | |
| B | .725 | .775 | 18.42 | 19.69 | |
| C | .595 | .625 | 15.11 | 15.88 | |
| D | 1.182 | 1.192 | 30.02 | 30.28 | |
| E | .736 | .744 | 18.70 | 18.90 | |
| F | .152 | .160 | 3.86 | 4.061 | ∅ |
| G | 1/4- 20 UNC | | | | |
| H | .540 | .580 | 13.72 | 14.73 | |
| J | .156 | .160 | 3.96 | 4.06 | |
| K | .480 | .492 | 12.20 | 12.50 | ∅ |
| L | .120 | .130 | 3.05 | 3.30 | |