



HMI Solution & Graphic Products



AIP 4''3

Hardware manual

CHAPTER 1: VERSION'S HISTORICAL BACKGROUND	3
CHAPTER 2: GENERAL DESCRIPTION	4
CHAPTER 3: LIST OF ENVIRONMENTAL REQUIREMENTS	5
ENVIRONMENTAL NORMS AND EMC	5
CHAPTER 4: SPECIFICATION OF THE PROGRAMMABLE INTELLIGENT DISPLAY	6
MECHANICAL AND ENVIRONMENTAL CHARACTERISTICS	6
HMI CHARACTERISTICS	6
IO SPECIFICATION	6
ELECTRICAL CHARACTERISTICS	7
CHAPTER 5: PIN OUT	8
CHAPTER 6: DESCRIPTION OF CONNECTIONS	9
CONNECTOR USB	9
CONNECTOR FROM J1 & J2	9
CHAPTER 7: EMBEDDED MAIN BOARD - <i>MASTER MODE MODEL</i>	10
MECHANICAL CONSTRAINTS	10
ELECTRICAL CHARACTERISTICS	11
CHAPTER 8: MECHANICAL DESCRIPTION	12
CHAPTER 9: MOUNTING RECOMMENDATION	13
CHAPTER 10: CLAIRITEC'S CONTACT	14

CLAIRITEC

ERREUR ! SIGNET NON DEFINI.

CHAPTER 1: VERSION'S HISTORICAL BACKGROUND

Reference	Modifications	Date
DOC-20160313-1A-UK	Creation	13/03/2017
DOC-20160313-1B-UK	Colors number and casings modification	10/10/2018

CHAPTER 2: GENERAL DESCRIPTION

The Programmable Intelligent Display is a "Plug & Play" graphic display module with integrated specific inputs and outputs. This product is developed & produced in France.

It consists of a TFT-LCD 4"3 WVGA (480 x 272 pixels) touchscreen display driven by an integrated HMI board from CLAIRITEC and an I/O management board. All these components are integrated into an IP65 protected casing. The Programmable Intelligent Display is EMC compliant and withstands a temperature range from -20°C to +70°C. It can easily fit into electronic equipment thanks to the modular structure of the casing.

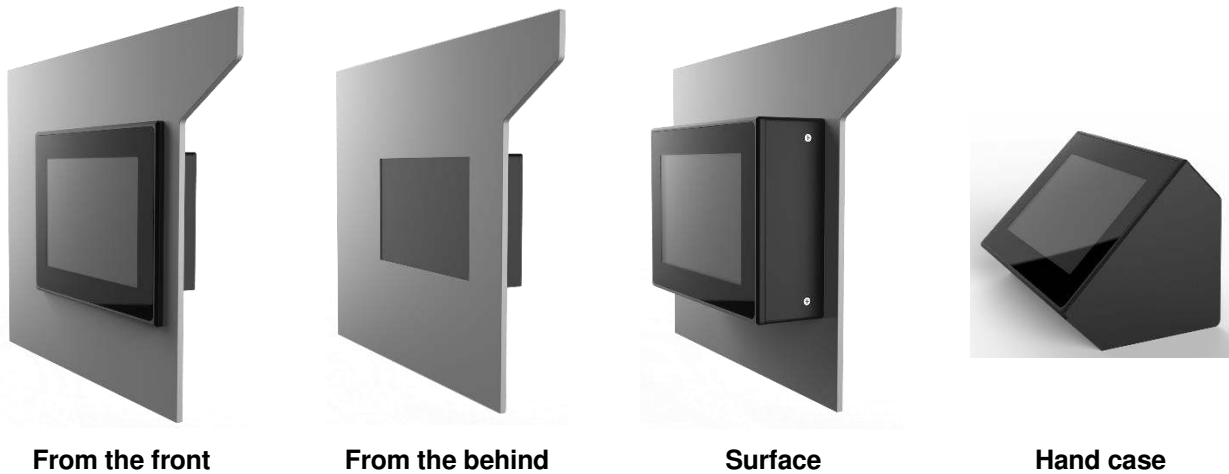
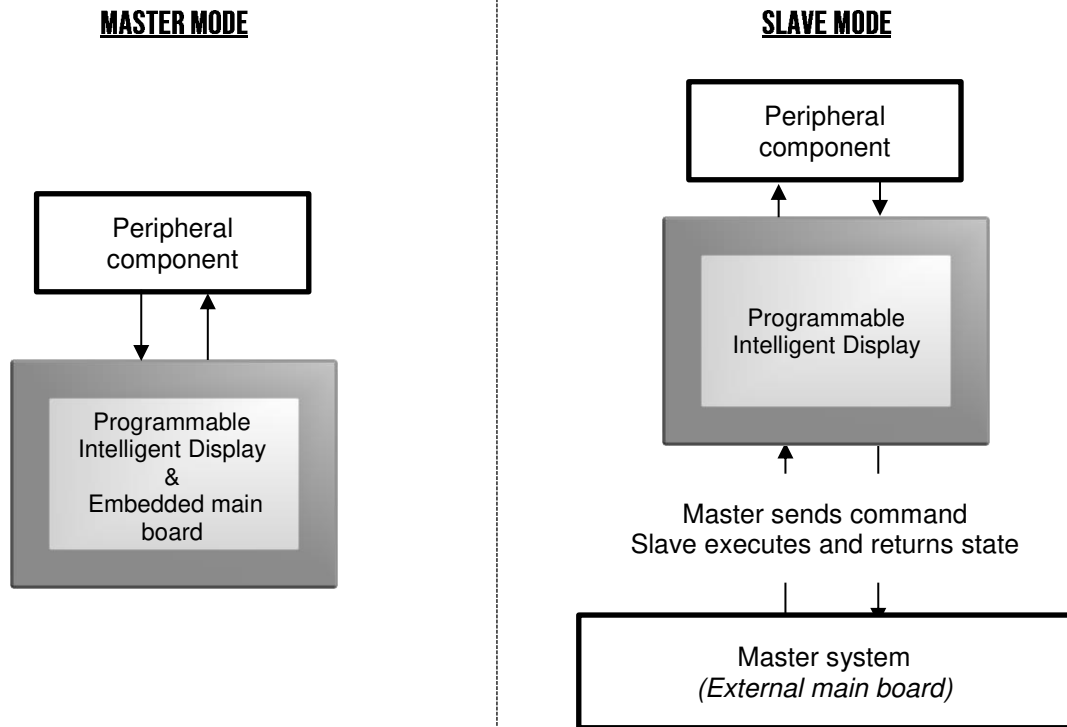

Figure 1 – Case's Topology

The product range consists of different versions, allowing for various application types. It can be used in 2 different modes: slave and master mode:



CHAPTER 3: LIST OF ENVIRONMENTAL REQUIREMENTS**ENVIRONMENTAL NORMS AND EMC**

The following table lists the environmental and EMC requirements that the Programmable Intelligent Display meets.

Norm	Minimum required
Environmental	
RoHS	All the components used in the Programmable Intelligent Display respect the RoHS norm
Electromagnetic compatibility (electronic board alone)	
NF EN-61000-4-3	Susceptibility 30 MHz - 1 GHz, 25Watt 10V/m
NF EN-55022	Conducted emission 150Khz – 30 MHz class B Radiated emission 30Mhz – 1Ghz class B
NF-EN-61000-4-2	Protected against 8kV electrostatic discharge in the air, 4kV at contact
UL 94 V-0	E76251 PCB agreement
Mechanical	
IP65	The front side is waterproof with the “from the front” casing
IP40	All the components are protected by this norm
Vesa 75x75	The “surface” and “table-top” cases are compatible with the VESA 75x75 system



WARNING: Any handling on the electronic board involves the risk of electrostatic discharge (ESD), which could destroy components.

We strongly advise you to wear an antistatic wrist strap connected to Earth. Similarly, the electronic boards must be transported inside a specific antistatic packaging

CHAPTER 4: SPECIFICATION OF THE PROGRAMMABLE INTELLIGENT DISPLAY**MECHANICAL AND ENVIRONMENTAL CHARACTERISTICS**

Item	Specifications
Size	4"3 Diagonal
Resolution	480 x RGB x 272 dots (WQVGA)
Viewing direction	6 o'clock
Viewing area	96.7 (W) x 55.5 (H) mm
Horizontal / Vertical flip	Unavailable
Backlight	White LED
Brightness	400 cd/m ²
Viewing angle (typ.)	120° Vertical / 140° Horizontal
Touch screen	4-wire resistive / 1 million touch times by finger Capacitive / Minimum of 50 million touch times by finger
Operating temperature	-20°C ~ +70°C
Storage temperature	-30°C ~ +80°C
EMC compliant	NF-EN55022 class B (Frequency range 150 kHz to 2 GHz) NF-EN61000-4-2 (8 kV contact discharge / 15 kV air discharge) NF-EN61000-4-3 (Frequency range : 30 MHz to 1 GHz – 10 V/m)
IP Certification	IP65 on the side face with recessed "from the front" casing IP40 on the other sides

HMI CHARACTERISTICS

Item	Specifications
Color LCD Management	From 4096 to 65k colors / TFT transmissive active matrix
Touchscreen Management	Advanced clicking area processing
Graphic Engine	Advanced display algorithms
Graphic layer Management	Two layers dynamically managed
Storage Memory	32 Mb
Graphical Layout Management	The GraphConverter®3 software tool enables you to build your HMI's graphic library and user interface and upload it to the HMI board's flash memory

IO SPECIFICATION

	Digital	Analogic	Relay	PT100	PWM	Internal RTC	Internal Buzzer
Input	5	4	-	1	-		
Output	4	1	4	-	1	1	1

ELECTRICAL CHARACTERISTICS

	Item	Symbol	Min	Typ	Max	Unit
Power	Power Supply voltage	V _{cc}	12	-	36	V
	Power Supply consumption*	I _{cc}	260	-	TBC	mA
	Max Intensity	I _{sat}	-	-	2	A
RS232	speed transmission	Bds	9,6	-	355	kBd
RS485	speed transmission	Bds	9,6	-	355	kBd
CAN	CAN 2.0B	Bds	100	-	500	kBd
USB	voltage reference	V _{USB}	2.7	5	5.5	V
	Continuous output current	I _{USB}	0	-	500	mA
PWM	PWM voltage high level	V _{PWM OH}	-	V _{cc}	-	V
	PWM voltage low level	V _{PWM LH}	-	0	-	V
	PWM intensity	V _{PWM I}	0	-	100	mA
	Frequency	V _{PWM F}	10	-	500k	Hz
	Duty cycle	V _{PWM Dt}	0	-	100	%
PT100	Temperature range	T° _{MIN MAX}	TBM	-	TBM	°C
Analog Input	Voltage	V _{in MAX}	0	-	10	V
	Resolution	R	-	10	-	bit
Analog Output	Voltage	V _{out MAX}	0	-	10	V
	Frequence	f	0	-	3	kHz
	Intensity	I _{out}	0	-	20	mA
	Resolution	R	-	8	-	bit
Relay NO	Intensity	I _{in}	0	-	2	A
	Voltage	V _{in}	0	-	220	Vdc
Relay NO/NC	Intensity	I _{in}	0	-	2	A
	Voltage	V _{in}	0	-	220	Vdc
Digital Output	Voltage Com	COM	5.5	-	40	V
	Voltage Out	V _{out}	0	-	COM	V
	Intensity per channel	I _{max}	0	-	2	A
Digital Input	Voltage Digital Input	V _{in}	0	-	V _{cc}	V

*Without peripherals

CHAPTER 5: PIN OUT

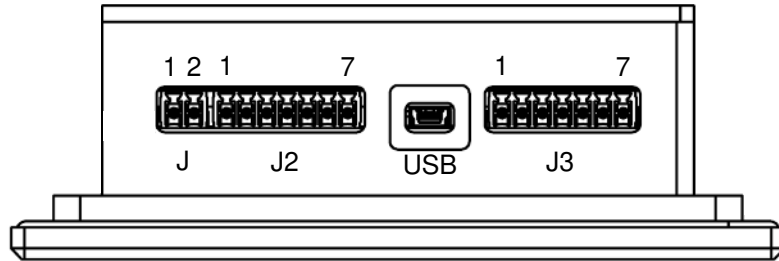

J1	1	Power Supply	POWER
	2	GND	
J2	1	CAN L	COMMUNICATIONS
	2	CAN H	
	3	GND	
	4	RS485 A	
	5	RS485 B RS232 TX	
	6	RS485 Z RS232 RX	
	7	RS485 Y	

CHAPTER 6: DESCRIPTION OF CONNECTIONS

The Clairitec Programmable Intelligent Display has three different connectors as shown in the drawing below:

CONNECTOR USB

This connector allows you to update the firmware and the graphic user interface via a computer or an USB key. Thanks to the transfer via USB connection, the loading time is decreased. A standard adapter USB -> mini USB, available in the Starter Kit, is required.

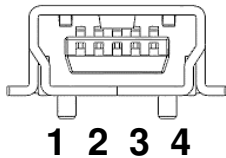

Pin	I/O	Description
1	Power	Power Supply +5V / 500mA max
2	I/O	USB -
3	I/O	USB +
4	-	Reserved
5	Power	GND

CONNECTOR J1 & J2

There are many different crosslinks models for this Plug and play connector:

- Wurth [691361300002](#) | [691361300007](#)
- Wurth [691368300002B](#) | [691368300007B](#)
- Wurth [691366310002](#) | [691366310007](#)
- Wurth [691363310002](#) | [691363310007](#)

CHAPTER 7: EMBEDDED MAIN BOARD – MASTER MODE VERSION

To be operated in Master mode, our system needs to embed a board which is programed like a state machine. Moreover, this board can integrate other specific I/O pinouts: protocol communication, and electronic system. Clairitec provides a standard main board, to which additional connectors or modules can be added upon request. You can also choose your own processor and schematic circuit. The following figures present the maximal and minimal dimension of this board. You can find this board dimension on the STEP file attached.

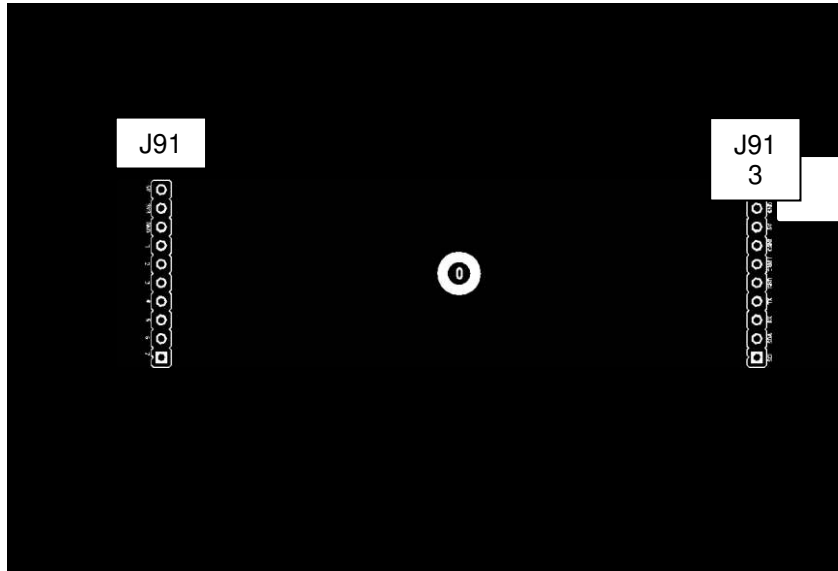

As can be seen in this scheme, the programmable board is placed above the HMI board. It is fixed by a screw in the middle and gets connected to the HMI board through a number of connectors (left and right).

MECHANICAL CONSTRAINTS

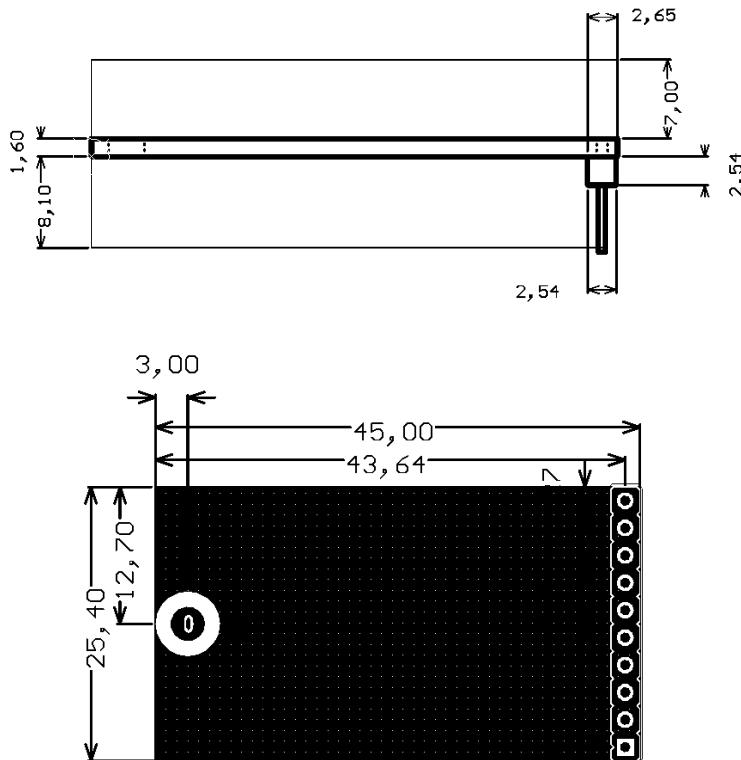

Unit : mm

The embedded main board cannot be smaller than the figure cannot be higher than 7mm on the upper side,

CLAIRITEC 13/03/2017	DOC-20170313-1B-UK	Page 10 / 15
Classification: CONFIDENTIAL	<i>Copy or communication inhibited without written authorization from Clairitec</i>	

and lower than 8,50mm on the bottom side. Beware of the connector and the screw hole.

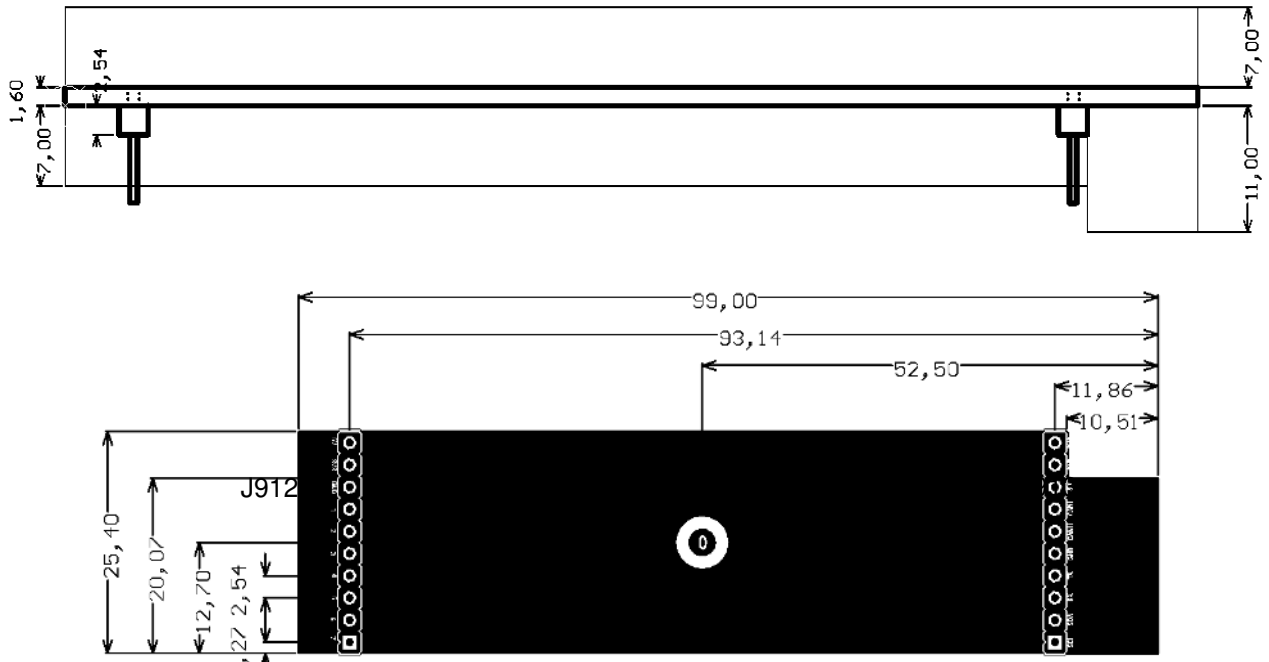

Unit : mm

The embedded main board cannot be bigger than the figure above (these dimensions are the maximum size. Components cannot be higher than 7mm on the upper side, and lower than 8,50mm on the bottom side. An exception is the right-hand bottom side: Here components can go down to 11 mm. Beware of the connector and the screw hole.

ELECTRICAL CHARACTRISTICS

The mechanical constraints show you that there is 2 connectors Male Barrel 1x10 with a 2,54mm step. This connectors allow to be connected with our main board.

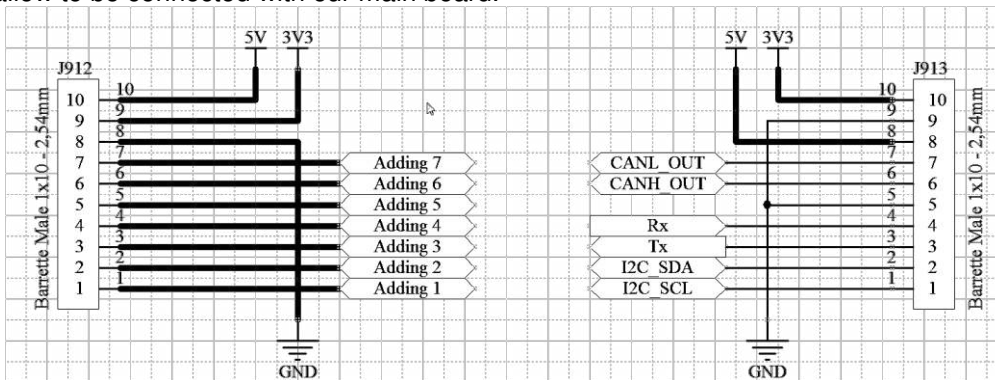

Item	Symbol	Min	Typ	Max	Unit	
5V	Power Supply voltage	V _{cc}	-	5	-	V
	Power Supply consumption	I _{cc}	0	-	500	mA
3V3	Power Supply voltage	V _{cc}	-	3.3	-	V
	Power Supply consumption	I _{cc}	0	-	300	mA
RS232 TTL *	Bauderate	Bds	9,6	-	355	kBd
CAN 2.0B *	Bauderate	Bds	100	-	500	kBd
I2C	Address Used - TBC	Addr	58 59 55 38			Hex
	Frequency - TBC	f	-	391	-	kHz
Adding	Intensity per Output	I _{out}	0	-	3	A

* PROGRAMMABLE INTELLIGENT DISPLAY COMMANDS ONLY

CHAPTER 8: MECHANICAL DESCRIPTION

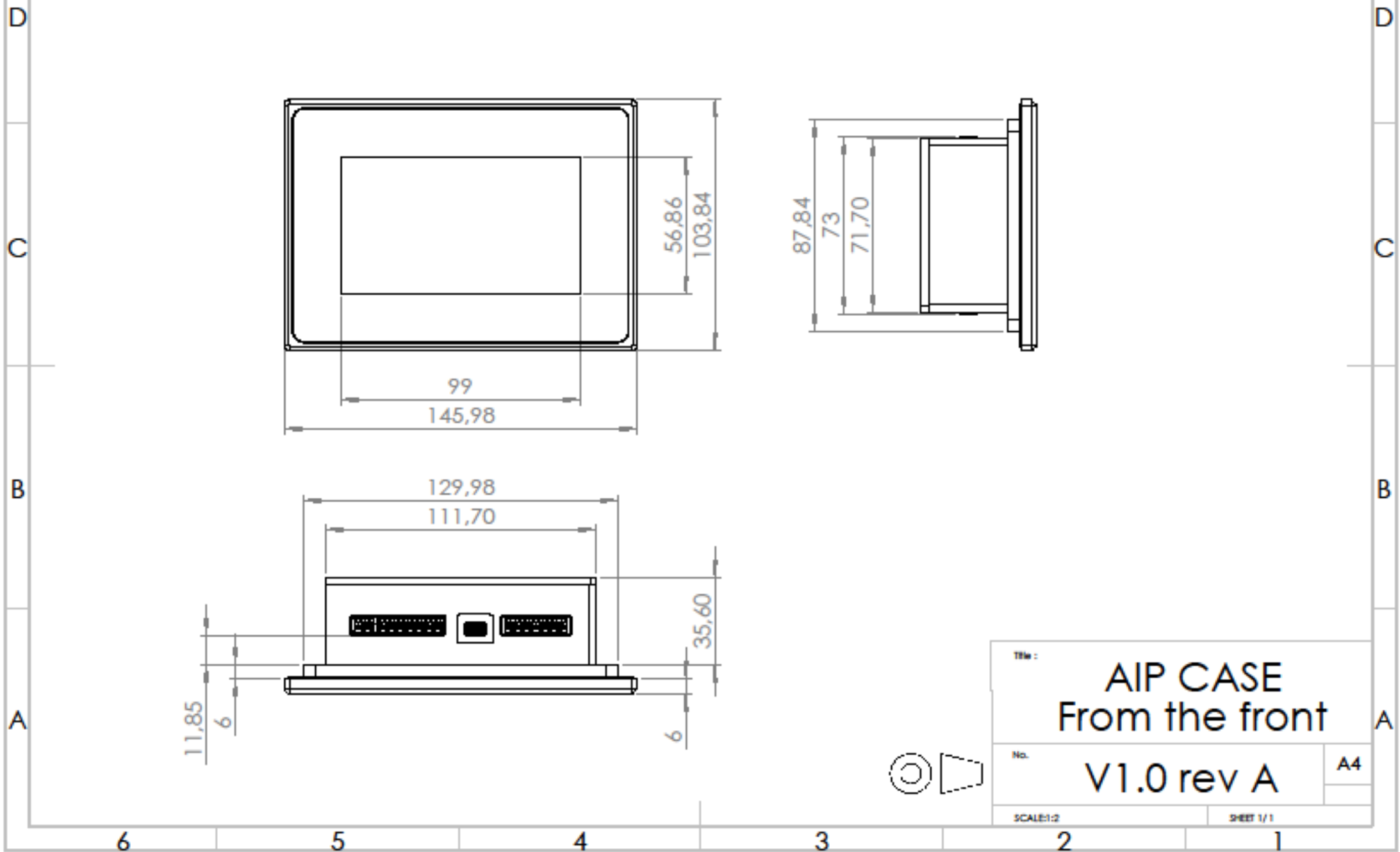

CHAPTER 9: MOUNTING RECOMMENDATION

To mount the product, the following figure shows you the ideal assembly:

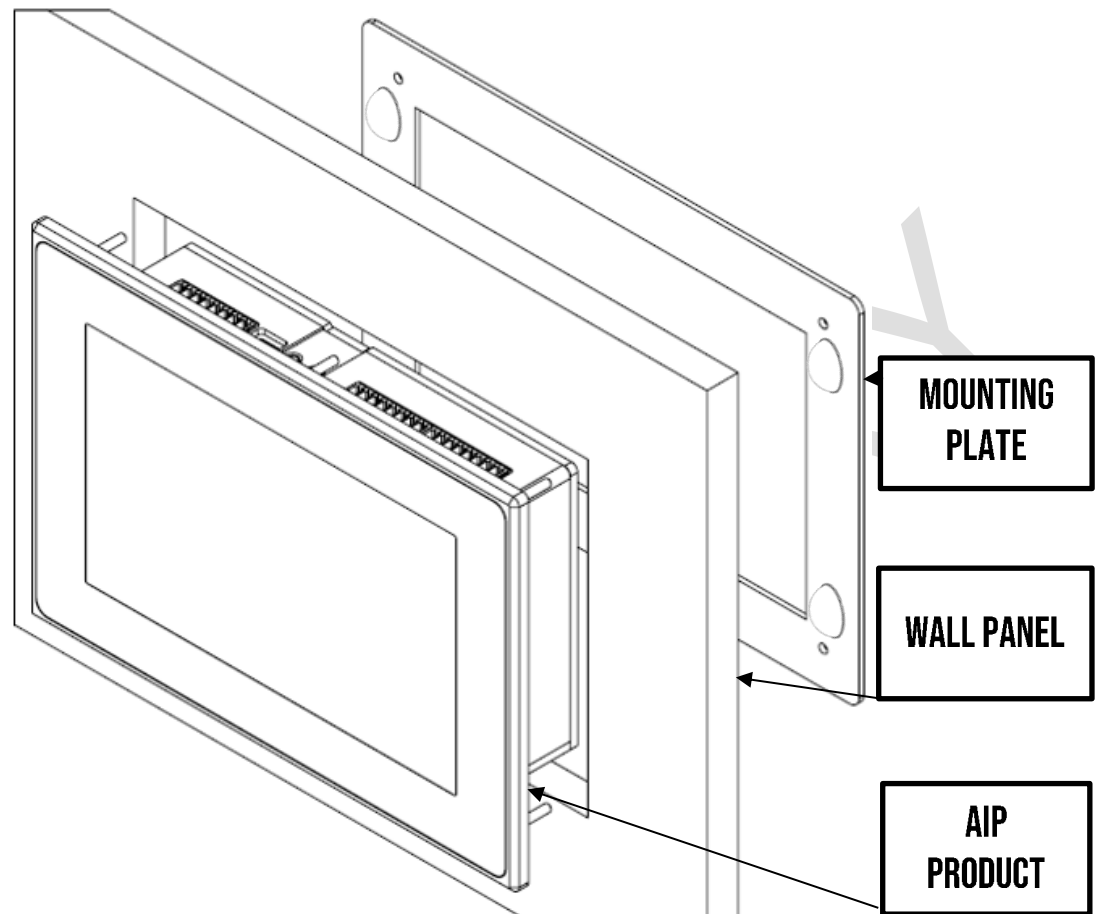

Firstly, cut your mounting plate to make a rectangle of dimensions 88x130mm. Place the AIP Product inside the hole. Then if you have a width mounting plate inferior at 5mm place the transparent adhesive stop on the support close to the fixation's hole. The maximal width of the wall panel is 13mm.

CHAPTER 10: CLAIRITEC'S CONTACT**Clairitec**

CLAIRITEC
11 avenue Henri Becquerel
33700 Mérignac
FRANCE

Website: www.clairitec.com

Clairitec's services

Customer relation service: contact@clairitec.com

Technical support service: support@clairitec.com



11, avenue Henri Bequerel - 33700 - MERIGNAC - FRANCE

Email: contact@clairitec.com
www.clairitec.com

