

W2E200A Series

Axial

Ø 200mm S-Range

- AC Axial fan with round venturi housing. Shallow depth with external rotor motor for exceptional performance and long life.
- Individual sickle blades made of sheet steel are welded onto the external-rotor motor and dynamically balanced.
- Direction of rotation is CCW looking at rotor.
- Maintenance-free ball bearings..
- Mounting plate with 7 mm holes. Ready to install.
- UL, CSA, VDE approvals on some models, please contact application engineering.

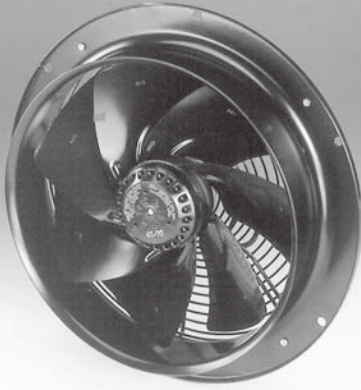

Part Number	Curve	CFM @ 0	VAC	Hertz	Power (kW)	dBA	Max. Amb. Temp C	Bearing Type	Features	Capacitor (µF)	Grill Position	Wgt. (lbs)
W4S200-CH16-70	1	315	115	50/60	27	46	80	Ball	Leads	-	Dischg	2.69
W4S200-CI16-70	1	315	115	50/60	27	46	80	Ball	Leads	-	Inlet	2.69
W2E200-CH86-70	2	600	115	50/60	77	62	70	Ball	Leads	5	Dischg	3.13
W2E200-CI86-70	2	600	115	50/60	77	62	70	Ball	Leads	5	Inlet	3.13
W4S200-CH04-70	1	315	230	50/60	27	46	80	Ball	Leads	-	Dischg	2.69
W4S200-CI04-70	1	315	230	50/60	27	46	80	Ball	Leads	-	Inlet	2.69
W2E200-CH38-70	2	600	230	50/60	77	62	70	Ball	Leads	1.5	Dischg	3.13
W2E200-CI38-70	2	600	230	50/60	77	62	70	Ball	Leads	1.5	Inlet	3.13

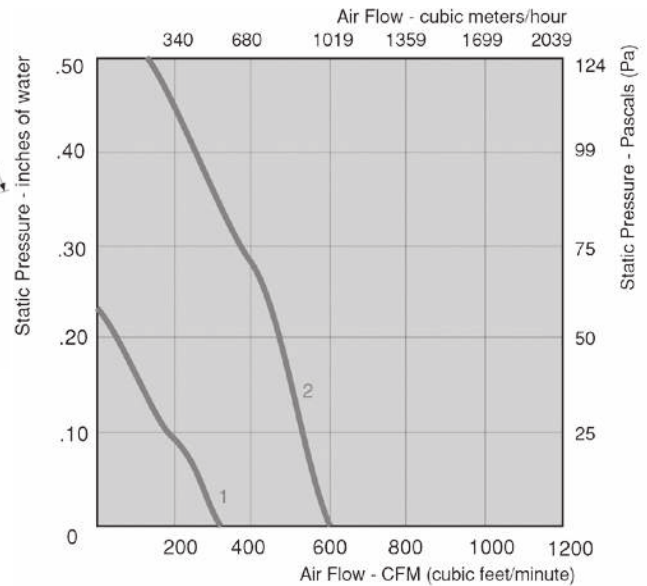
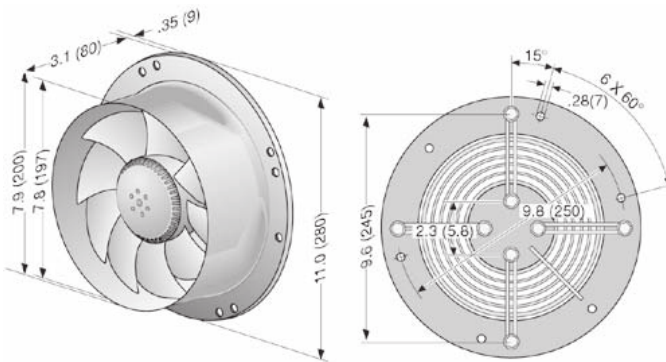

ebmpapst

e-mail: sales@us.ebmpapst.com · TEL: 860-674-1515 · FAX: 860-674-8536

ebm-papst Inc., 100 Hyde Road, Farmington, CT 06034 USA

ebm-papst Inc., 2004 © ebm-papst Inc. reserves the right to change any specifications or data without notice