

| ITEM | QTY | PART NUMBER | PART DESCRIPTION |
|------|-----|-------------|--|
| 1 | 1 | HT3 | T1 (3mm) High Temperature Single Level Holder, 90° Mount |
| 2 | 1 | BDL-XXXX | T1 (3mm) N-Flange LED, See Page 2 |

| REV. | DESCRIPTION | DATE | APPROVED |
|------|--------------------------------|----------|----------|
| B | Engineering Release | 04/19/11 | T. Y. |
| C | Engineering Update w/o Changes | 06/25/16 | J. C. |
| | | | |
| | | | |

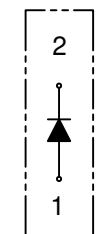

Single Color

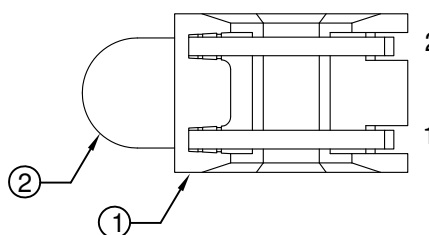
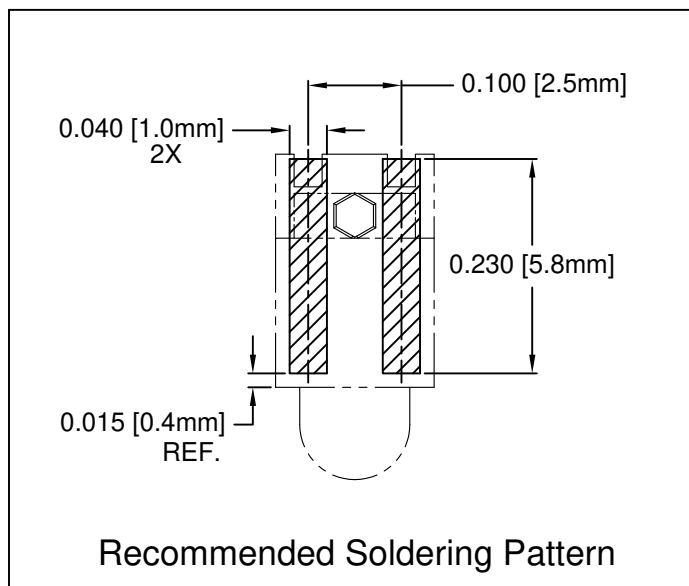
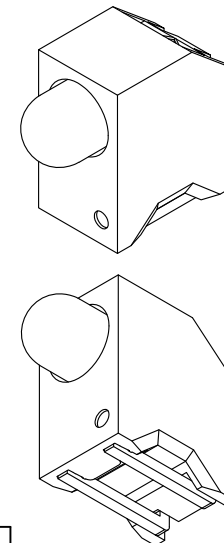
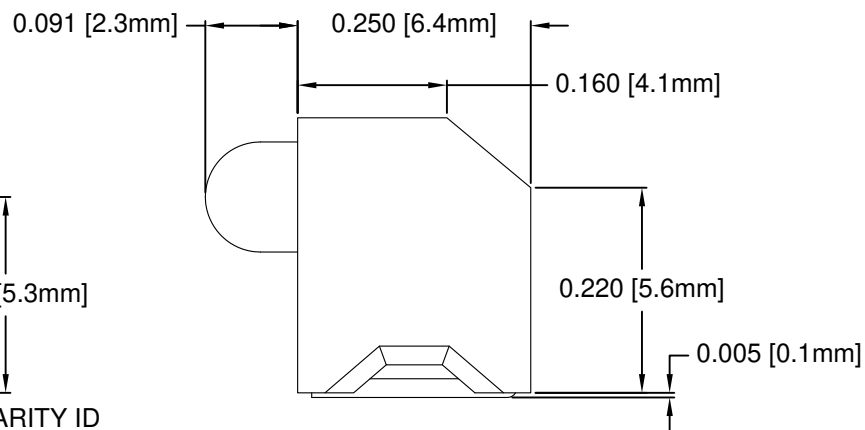
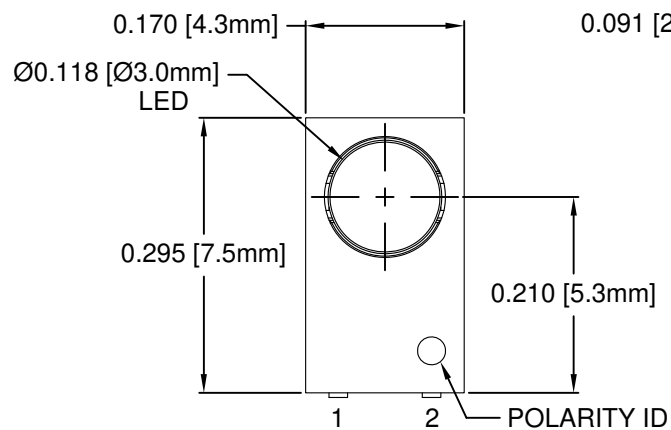
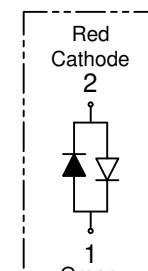

HT3-BC-T

ABSOLUTE MAXIMUM RATINGS (Ta=25° C)

| | | |
|---|-------|----------------------|
| REVERSE VOLTAGE | _____ | 5V |
| REVERSE CURRENT | _____ | 100uA |
| OPERATING TEMPERATURE RANGE | _____ | -25° C - 85° C |
| STORAGE TEMPERATURE | _____ | -30° C - 100° C |
| LEAD SOLDERING TEMPERATURE(1/16" FROM BODY) | _____ | 260° C FOR 5 SECONDS |

| STANDARD TOLERANCE (UNLESS OTHERWISE SPECIFIED) | | 4 THOMAS, IRVINE, CA. 92618 TEL: (949) 951-8808 FAX: (949) 951-3974 | |
|--|--------------------------|--|--|
| DECIMALS | ANGULAR | | |
| .X ± .1 | X° ± 1° | | TITLE: T1 (3mm) SMT 90° SURFACE MOUNT LED, TAPE AND REEL PART NO: HT3-XXX-T REVISION: C CAGE CODE : 32559 SHEET # 1 OF 3 CAD GENERATED DOCUMENT. DO NOT MEASURE DRAWING. |
| .XX ± .02 | | | |
| .XXX ± .010 | | | |
| DESIGNED: R. Paje | DATE: 04/26/10 | | |
| CHECKED: T. Yin | DATE: 04/26/10 | | |

| | | | |
|------|--------------|------|----------|
| REV. | DESCRIPTION | DATE | APPROVED |
| | SEE SHEET #1 | | |
| | | | |

AVAILABLE CONFIGURATIONS

| Assy P/N | Emitted Color | Peak Wave Length λ_p (nm) | Lens Appearance | Absolute Max. Ratings | | | Vf (V) | | Iv (mcd) | Viewing Angle $2\theta_{1/2}$ (Deg) | LED P/N |
|--|---------------|-----------------------------------|-----------------|-----------------------|---------|--------------|--------|-----|----------|-------------------------------------|----------|
| | | | | Pd (mW) | If (mA) | Peak If (mA) | TYP | MAX | TYP | | |
| | | | | | | | | | | | |
| STANDARD SINGLE COLOR LED ASSEMBLIES (20mA) | | | | | | | | | | | |
| HT3-BLU-T | BLUE | 430 | DIFFUSED | 150 | 25 | 70 | 4.0 | 4.5 | 10 | 40 | BDL-1358 |
| HT3-GRN-T | GREEN | 568 | | 80 | 30 | 150 | 2.1 | 2.8 | 25 | 40 | BDL-1355 |
| HT3-RED-T | HE RED | 625 | | 80 | 30 | 150 | 2.0 | 2.8 | 30 | 40 | BDL-1356 |
| HT3-YEL-T | YELLOW | 590 | | 85 | 30 | 150 | 2.0 | 2.8 | 20 | 40 | BDL-1357 |
| STANDARD BI-COLOR LED ASSEMBLIES (20mA) | | | | | | | | | | | |
| HT3-BC-T | RED | 625 | WHITE DIFFUSED | 80 | 30 | 150 | 2.0 | 2.8 | 6 | 45 | BDL-1351 |
| | GREEN | 568 | | 80 | 30 | 150 | 2.1 | 2.8 | 6 | | |

CONVECTIVE REFLOW SOLDERING PROFILE

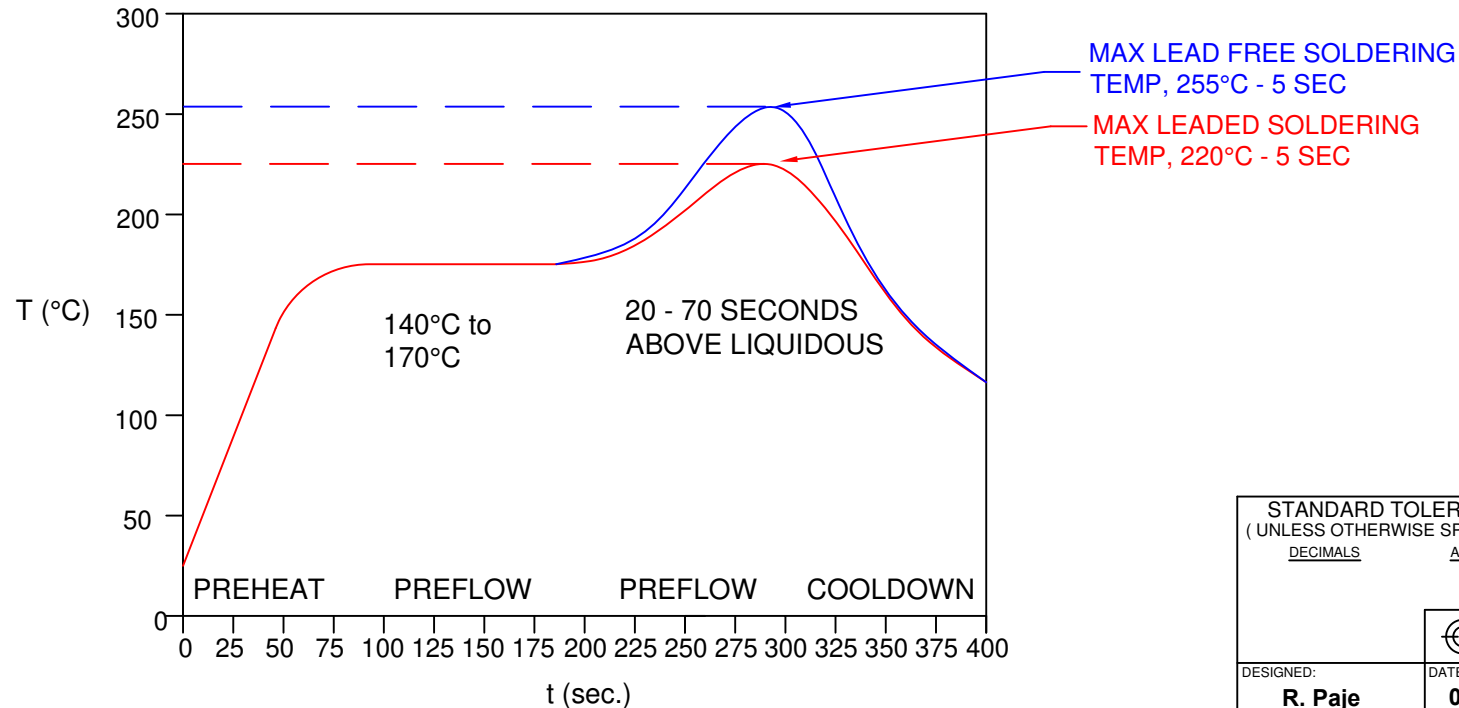

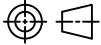
| | | | |
|--|--------------------------|---|-----------------------|
| STANDARD TOLERANCE (UNLESS OTHERWISE SPECIFIED) | |  BIVAR [®] 4 THOMAS, IRVINE, CA. 92618 TEL: (949) 951-8808 FAX: (949) 951-3974 | |
| DECIMALS | ANGULAR | | |
| | |  TITLE: T1 (3mm) SMT 90° SURFACE MOUNT LED, TAPE AND REEL | |
| DESIGNED: R. Paje | DATE: 04/26/10 | PART NO: HT3-XXX-T | REVISION: C |
| CHECKED: T. Yin | DATE: 04/26/10 | CAGE CODE : 32559 | SHEET # 2 OF 3 |
| CAD GENERATED DOCUMENT. DO NOT MEASURE DRAWING. | | | |

| REV. | DESCRIPTION | DATE | APPROVED |
|------|--------------|------|----------|
| | SEE SHEET #1 | | |

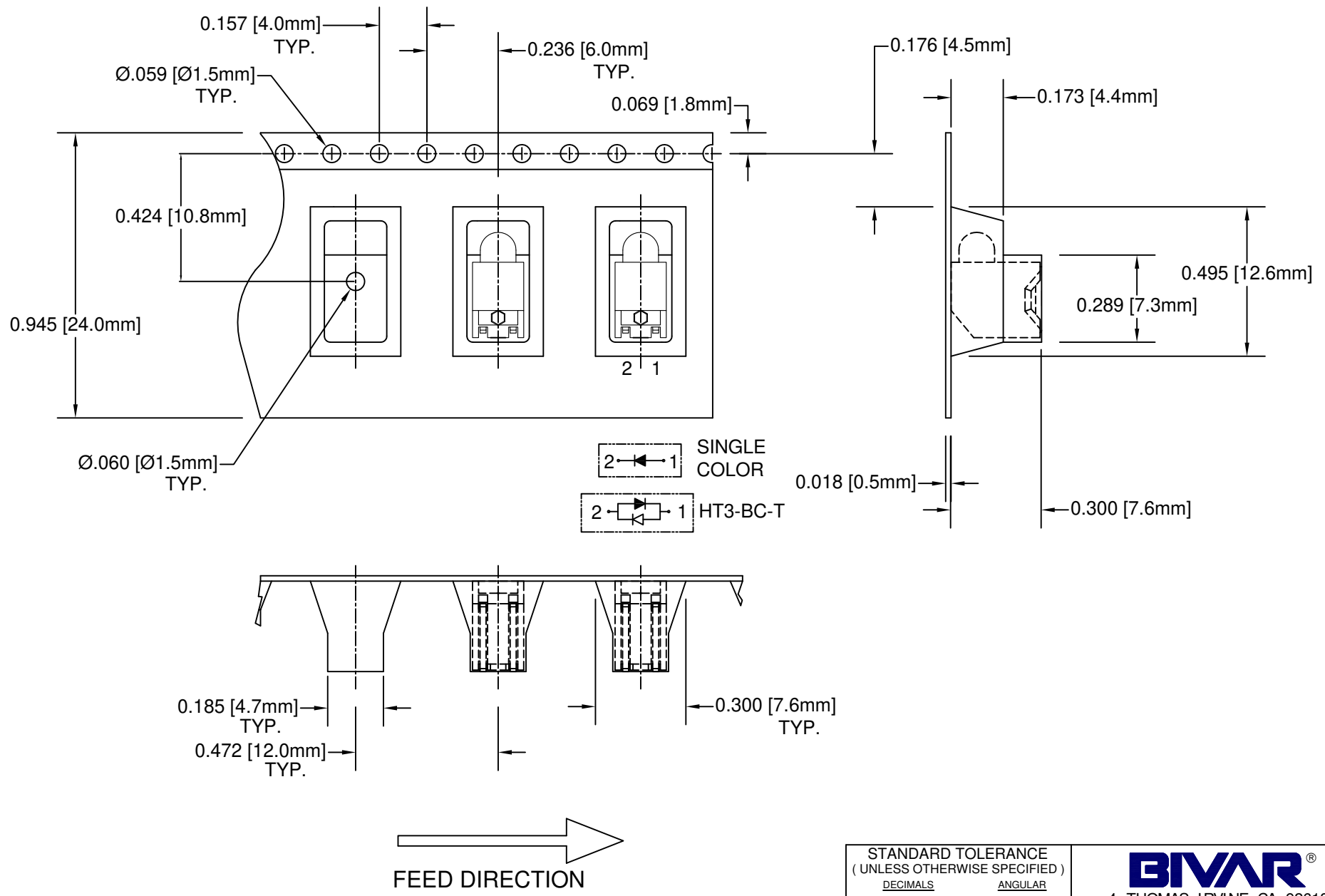

NOTES:
 2. UNLESS OTHERWISE SPECIFIED, PACKAGING TO COMPLY WITH EIA-481-D.
 1. 750 pcs PER REEL

| STANDARD TOLERANCE (UNLESS OTHERWISE SPECIFIED) | | BIVAR® | |
|--|----------------|---|-----------------------|
| DECIMALS | ANGULAR | 4 THOMAS, IRVINE, CA. 92618 | |
| .X ± .1 | X° ± 1° | TEL: (949) 951-8808 FAX: (949) 951-3974 | |
| .XX ± .02 | | TITLE: T1 (3mm) SMT 90° SURFACE MOUNT LED, TAPE AND REEL | |
| .XXX ± .010 | | PART NO: HT3-XXX-T | REVISION: C |
| DESIGNED: R. Paje | DATE: 04/26/10 | CAGE CODE : 32559 | SHEET # 3 OF 3 |
| CHECKED: T. Yin | DATE: 04/26/10 | CAD GENERATED DOCUMENT. DO NOT MEASURE DRAWING. | |