

## Interactive Catalog Replaces Catalog Pages

Honeywell Sensing and Control has replaced the PDF product catalog with the new **Interactive Catalog**. The **Interactive Catalog** is a power search tool that makes it easier to find product information. It includes more installation, application, and technical information than ever before.



**Click this icon to try the new  
Interactive Catalog.**

---

### **Sensing and Control**

Honeywell Inc.

11 West Spring Street

Freeport, Illinois 61032

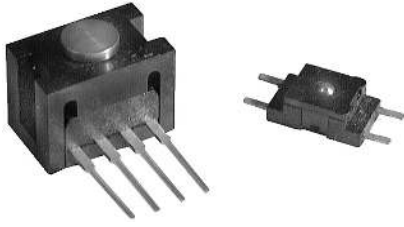

### FEATURES

- Compact commercial grade package
- Robust performance characteristics
- Adaptable product design
- Precision force sensing
- Electrically ratiometric output
- Extremely low deflection (30 microns typ. @ Full Scale)
- High ESD resistance 10 KV
- Available signal conditioning
- Optional terminal configurations

The FS Series Force Sensors provide precise, reliable force sensing performance in a compact commercial grade package. The sensor features a proven sensing technology that utilizes a specialized piezoresistive micro-machined silicon sensing element. The low power, unamplified, noncompensated Wheatstone bridge circuit design provides inherently stable mV outputs over the force range.

Force sensors operate on the principle that the resistance of silicon implanted piezoresistors will increase when the resistors flex under any applied force. The sensor concentrates force from the application, through the stainless steel plunger, directly to the silicon sensing element. The amount of resistance changes in proportion to the amount of force being applied. This change in circuit resistance results in a corresponding mV output level.

The sensor package design incorporates a patented modular construction. The use of innovative elastomeric technology and engineered molded plastics results in load capacities of 4.5 Kg over-force. The stainless steel plunger provides excellent mechanical stability and is adaptable to a variety of applications. Various electrical interconnects can accept pre-wired connectors, printed circuit board mounting, and surface mounting. The unique sensor design also provides a variety of mounting options including mounting brackets, as well as application specific mounting requirements.

### MOUNTING

Sensor output characteristics do not change with respect to mounting orientation. Care should be taken not to obstruct the vent hole in the bottom of the housing. Improper venting may result in unstable output.

### APPLYING FORCE

Evaluation of the sensor is to be performed using deadweight or compliant force. Application of a rigid, immobile force will result in output drift (decrease) as elastomeric seals relax. Off-center plunger loading has minimal effect on sensor performance and maintains operation within design specifications.

### ELECTRICAL CONNECTIONS

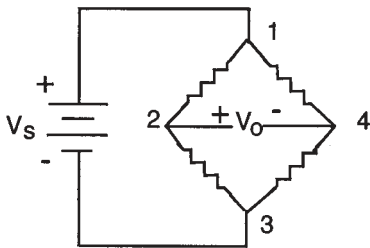

### FS SERIES CIRCUIT NOTES

1. Circled numbers refer to Sensor Terminals (interface pins).  
Pin 1 =  $V_s$  (+)  
Pin 2 = Output, (+)  
Pin 3 = Ground, (-)  
Pin 4 = Output, (-)
2. The force sensor may be powered by voltage or current.  
Maximum supply voltage is not to exceed 12 volts.  
Maximum supply current is not to exceed 1.6 mA. Power is applied across Pin 1 and Pin 3.
3. The sensor output should be measured as a differential voltage across Pin 2 and Pin 4 ( $V_o = V_2 - V_4$ ). The output is ratiometric to the supply voltage. Shifts in supply voltage will cause shifts in output. Neither Pin 2 nor Pin 4 should be tied to ground or voltage supply.

# Force Sensors

## FSG and FSL Series

FS Series

### MOUNTING DIMENSIONS (for reference only)

#### FSG15N1A

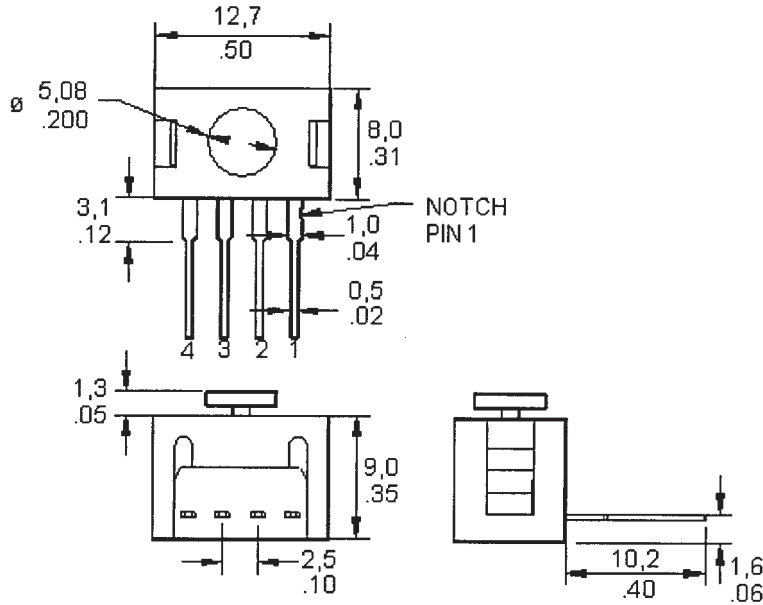

### ACCESSORY (FSG Sensor only)

#### PC-15132 Plastic Mounting Bracket

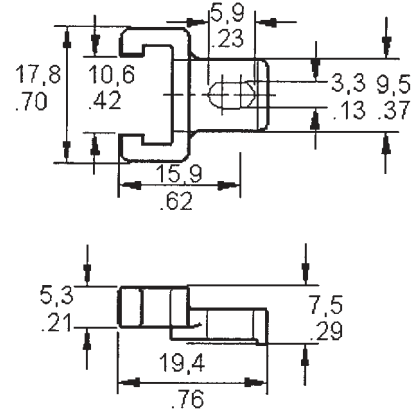

### PERFORMANCE CHARACTERISTICS @ 10.0 ±0.01 VDC, 25°C

Parameter	Min.	Typ.	Max.	Units
Excitation*	—	10.0	12.0	VDC
Null offset	-30	0	30	mV
Operating Force	0	—	1500	grams
Sensitivity	0.20	0.24	0.28	mV/gram
Linearity (B.F.S.L.)**	—	±22.5	45	grams
Null Shift				
+25°C to 0°C, +25°C to +50°C	—	±1.0	—	mV
Sensitivity Shift				
+25°C to 0°C	—	0.012	—	mV/gram
+25°C to +50°C	—	-0.012	—	mV/gram
Hysteresis	—	45	180	grams
Repeatability (@ 1500 grams)	—	30	120	grams
Input Resistance	4.0 K	5.0 K	6.0 K	Ohms
Output Resistance	4.0 K	5.0 K	6.0 K	Ohms
Overforce	—	—	4,500	grams

### ENVIRONMENTAL SPECIFICATIONS

Operating Temperature	-40° to 85°C (-40° to +185°F)
Storage Temperature	-55° to +105°C (-131° to +221°F)
Vibration	Qualification tested to 10 Hz to 2 kHz, 20 g sine
Shock	Qualification tested to 150 g, 6 ms, half-sine
Solderability	5 sec at 315°C per lead
Output ratiometric	Within Supply Range

\*\*B.F.S.L.—Best Fit Straight Line

Note: All force related specifications established using dead weight or compliant force.

### Constant Current Excitation Schematic

\* Non-compensated force sensors, excited by constant current instead of voltage, exhibit temperature compensation of Span. Application Note #1 briefly discusses current excitation.

Constant current excitation has an additional benefit of temperature measurement. When driven by a constant current source, a silicon pressure sensor's terminal voltage will rise with increased temperature. The rise in voltage not only compensates the Span, but is also an indication of die temperature.

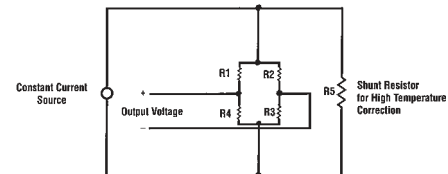

### FS SERIES ORDER GUIDE

Catalog Listing	Force Range (grams)	Sensitivity mV/V/gram			Span mV	Over Force grams
		Min.	Typ.	Max.	Typ.	Max.
FSG15N1A	1,500	.02	.024	.028	360 (at 10 VDC)	4,500

# Force Sensors

## FSG and FSL Series

FS Series



### MOUNTING DIMENSIONS (for reference only)

#### FSL05N2C

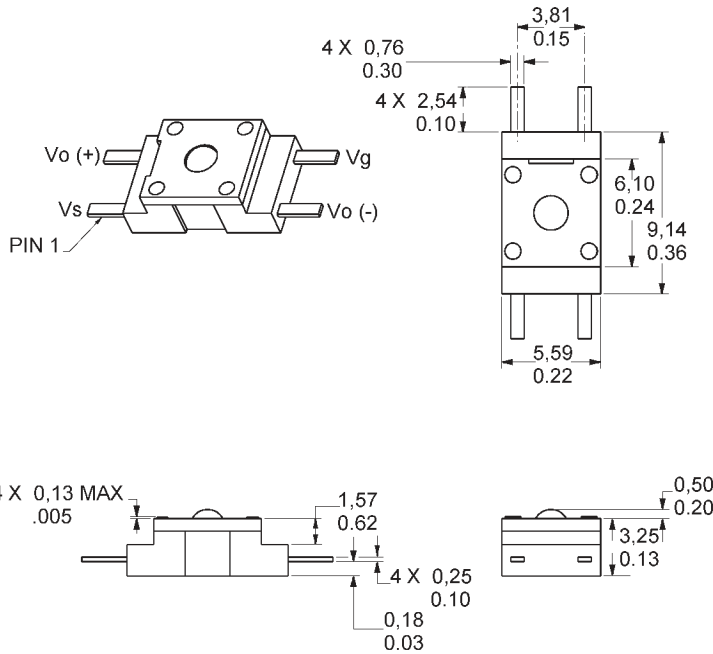

### PERFORMANCE CHARACTERISTICS @ 5.0 ±0.01 Excitation, 25°C

Parameter	Min.	Typ.	Max.	Units
Excitation*	—	5.0	12	VDC
Null offset	-15	0	15	mV
Operating Force	0	—	500	grams
Sensitivity	0.1	0.12	0.14	mV/gram
Linearity (B.F.S.L.)**	—	±10	—	grams
Repeatability @ 300 g	—	±10	—	grams
Null Shift				
+25°C to 2°C, +25°C to +40°C	—	±0.5	—	mV
Sensitivity Shift				
+25°C to 2°C	—	0.012	—	mV/gram
+25°C to +40°C	—	-0.012	—	mV/gram
Input Resistance	4.0 K	5.0 K	6.0 K	Ohms
Output Resistance	4.0 K	5.0 K	6.0 K	Ohms
Overforce	—	—	4,500	grams
ESD (Direct contact, terminals and plunger)	10	—	—	kVolts

### ENVIRONMENTAL SPECIFICATIONS

Operating Temperature	+2°C to +40°C (+36°F to +104°F)
Storage Temperature	-40° to +70°C (-40° to +158°F)
Vibration	Qualification tested to 10 Hz to 2 kHz, 20 g sine
Shock	Qualification tested to 150 g, 6 ms, half-sine
MCTF	7 million
Solderability	5 sec at 315°C per lead
Output ratiometric	Within Supply Range

\*\*B.F.S.L.—Best Fit Straight Line

Note: All force related specifications established using dead weight or compliant force.

### FS SERIES ORDER GUIDE

Catalog Listing	Force Range (grams)	Sensitivity mV/V/gram			Span mV	Over Force grams
		Min.	Typ.	Max.	Typ.	Max.
FSL05N2C	500	.02	.024	.028	60 (at 5 VDC)	4,500

Force

### Constant Current Excitation Schematic

\* Non-compensated force sensors, excited by constant current instead of voltage, exhibit temperature compensation of Span. Application Note #1 briefly discusses current excitation.

Constant current excitation has an additional benefit of temperature measurement. When driven by a constant current source, a silicon pressure sensor's terminal voltage will rise with increased temperature. The rise in voltage not only compensates the Span, but is also an indication of die temperature.

