

CUSTOMER PART NO.	PART NO.	"L" MAX. ±.015	I.D. MIN.	MATERIAL THICKNESS	WIRE SIZE
RT-2016	19702-4001	1.63	.060	.021	AWG 20-16
RT-1410	19702-4101	1.66	.128	DUAL THICKNESS .021/.026	AWG 14-10

NOTES:
 1. MATERIAL: PHOSBRONZE.
 2. PLATING: SILVER.
 3. BARREL BRAZED CLOSED.
 4. MATERIAL THICKNESS: SEE CHART.

AWG 14-10 VIEW

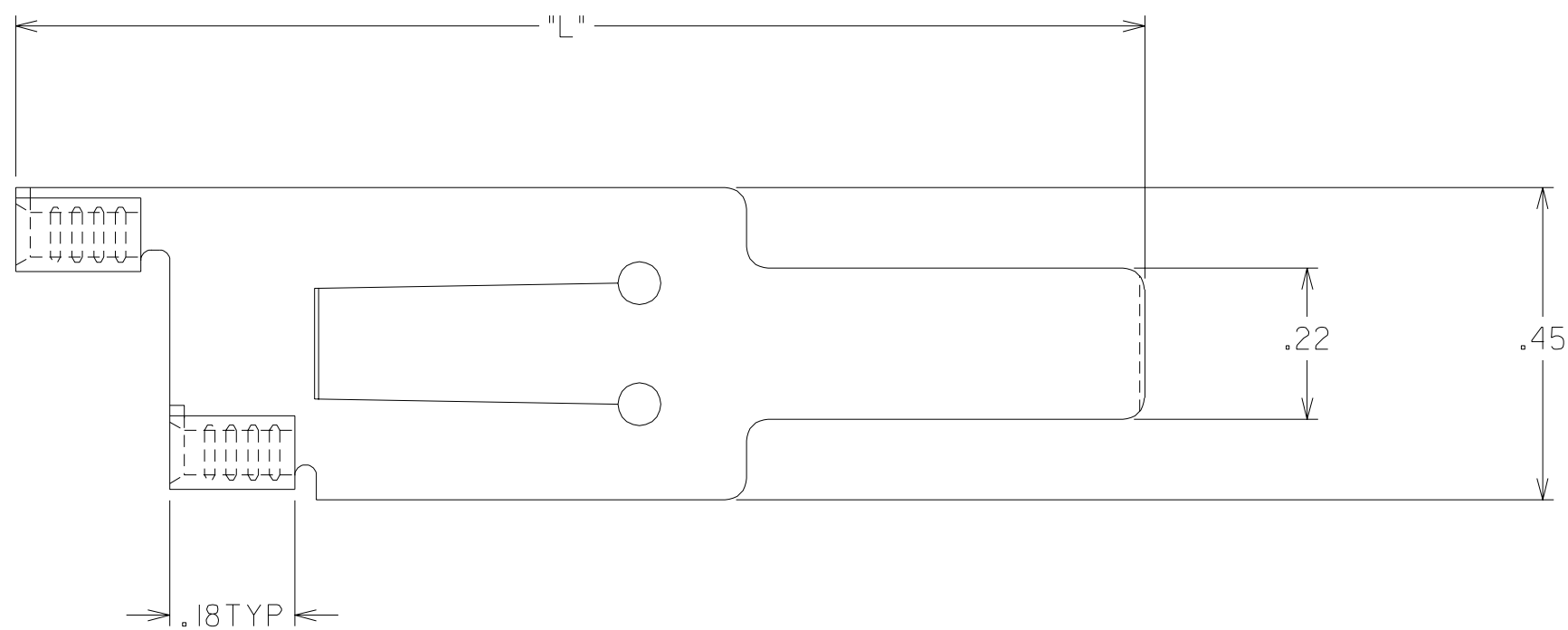
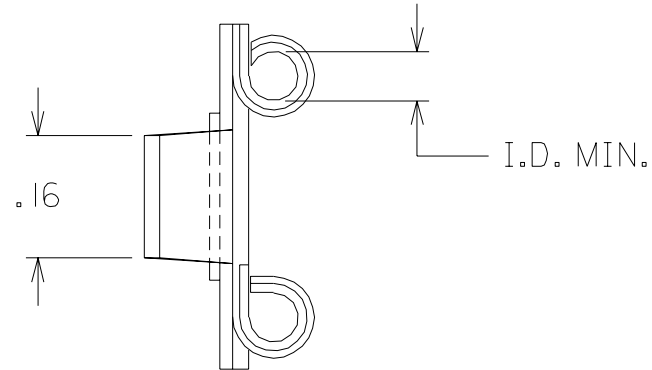
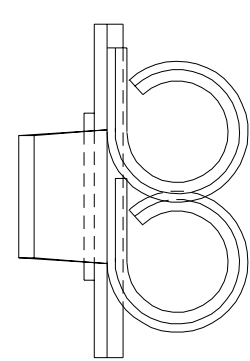

DUAL THICKNESS DETAIL

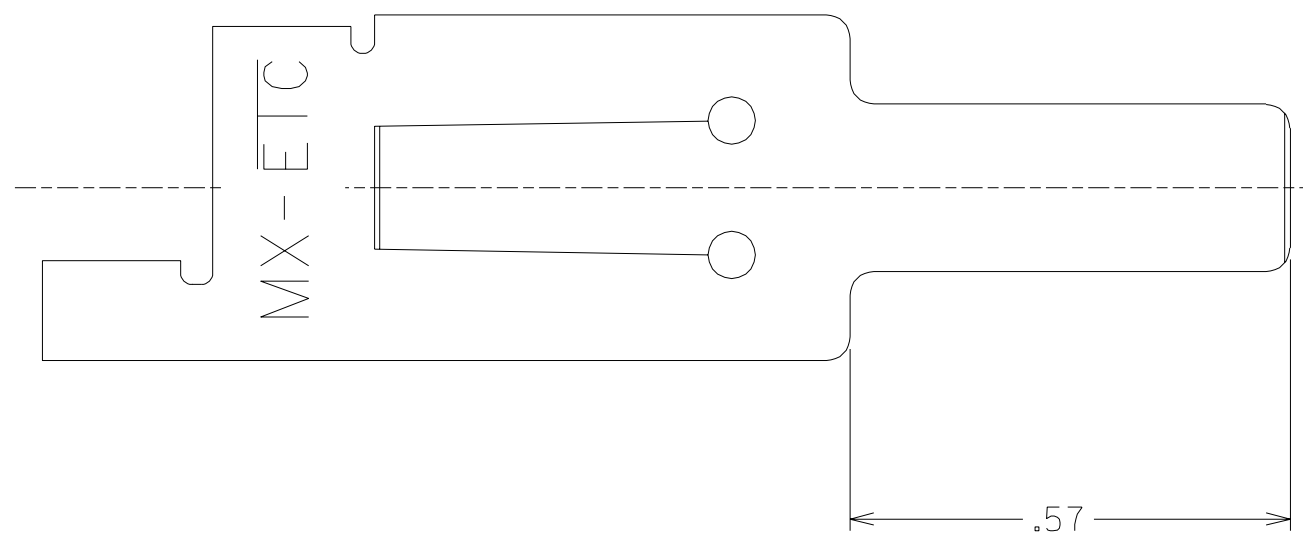
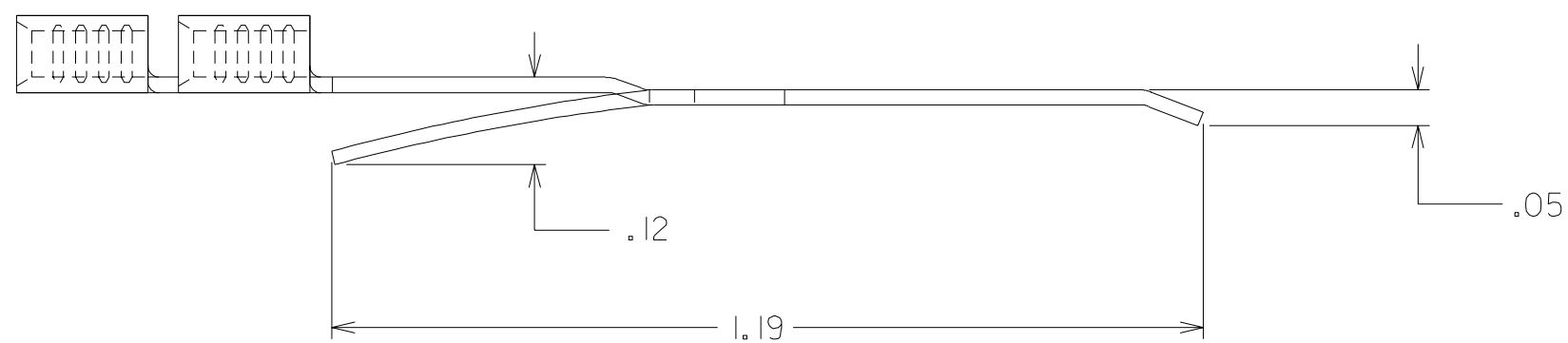
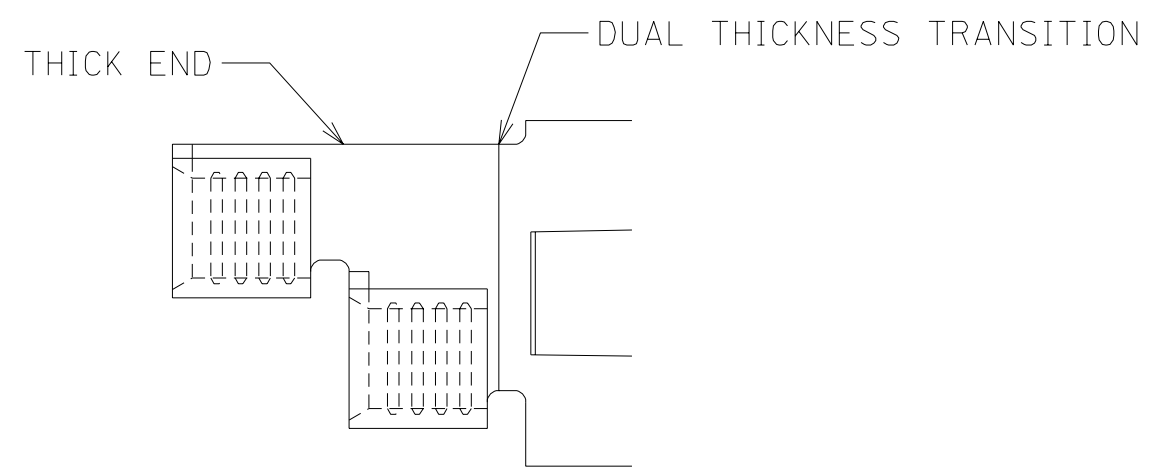

LTR.	REVISIONS
B-2	LOAD INTO WM ETC2003-0200 03-02-10 BRE
B-1	19702-4001 WAS -4000; 19702-4101 WAS -4100 ECN70887 7/1 DAY
B	ADD COLUMN TO CHART ECN60601 11/96 JH
A	RELEASE CUSTOMER DRAWING ECN60593 10/25 JH

CUSTOMER DRAWING

DIMENSIONS SHOWN (METRIC) INCH UNLESS OTHERWISE SPECIFIED TOLERANCES: ANGULAR ± 1/2°		REVISE ONLY ON CAD SYSTEM													
<table border="1"> <thead> <tr> <th></th> <th>INCH</th> <th>METRIC</th> </tr> </thead> <tbody> <tr> <td>3 PLACE</td> <td>± .005</td> <td>± ---</td> </tr> <tr> <td>2 PLACE</td> <td>± .01</td> <td>± 0.13</td> </tr> <tr> <td>1 PLACE</td> <td>± ---</td> <td>± 0.25</td> </tr> </tbody> </table>			INCH	METRIC	3 PLACE	± .005	± ---	2 PLACE	± .01	± 0.13	1 PLACE	± ---	± 0.25	TITLE RAILROAD RELAY TERMINAL CUSTOMER DRAWING	
	INCH	METRIC													
3 PLACE	± .005	± ---													
2 PLACE	± .01	± 0.13													
1 PLACE	± ---	± 0.25													
DRAFT WHERE APPLICABLE MUST REMAIN WITHIN DIMENSIONS		SHEET NO. DATE 96/10/23													
DRWG. BY: JH CHK'D. BY: RWD		PART NO. DRWG. NO. 19702400													
APP'D. BY: RWD SCALE: NO:NE		SEE CHART 19702400													
FILE NAME: 19702400.CST		THIS DRAWING CONTAINS INFORMATION THAT IS PROPRIETARY TO MOLEX-ETC INC. AND SHOULD NOT BE USED WITHOUT WRITTEN PERMISSION.													